

<p>NPN型 低频放大 小功率 贴片三极管 NPN Plastic-Encapsulate Transistors SMD</p>	<p>S8050 对应其他工业型号</p>
<ul style="list-style-type: none"> ■ High breakdown voltage ■ Low collector-emitter saturation voltage ■ Transistor Polarity: NPN ■ Transistor pinout: BEC ■ SOT-23 Package ■ Marking Code: J3Y 	

<p>Inner circuit</p> <p>SOT-23 内部结构</p>	<p>S8050</p> <p>SOT-23 管脚排列</p> <p>1. Base 2. Emitter 3. Collector</p>	<p>元件标识 (打印)</p> <p>DEVICE MARKING</p>
---	--	--

■ CLASSIFICATION OF hFE

RANK	L	H
RANGE	100~200	200~300

■ MAXIMUM RATINGS

Symbol	Parameter	Value	Unit
V_{CB0}	Collector-Base Voltage	40	V
V_{CEO}	Collector-Emitter Voltage	25	V
V_{EBO}	Emitter-Base Voltage	5	V
I_C	Collector Current	500	mA
P_C	Collector Power Dissipation	225	mW
T_J, T_{stg}	Operation Junction and Storage Temperature Range	-55~+150	°C

■ ELECTRICAL CHARACTERISTICS ($T_A=25^\circ\text{C}$ unless otherwise noted)

Characteristic	Test Condition	Symbol	Min	Typ	Max	Unit
Collector Cutoff Current	$V_{CB}=40\text{V}, I_E=0$	I_{CBO}	--	--	0.1	μA
Emitter Cutoff Current	$V_{EB}=5\text{V}, I_C=0$	I_{EBO}	--	--	0.1	μA
Collector-Base Breakdown Voltage	$I_E=0, I_C=100\mu\text{A}$	$V_{(BR)CBO}$	40	--	--	V
Collector-Emitter Breakdown Voltage	$I_E=0, I_C=10\text{mA}$	$V_{(BR)CEO}$	25	--	--	V
Emitter Cutoff Current	$I_C=0, I_E=100\mu\text{A}$	$V_{(BR)EBO}$	5	--	--	V
DC Current Gain	$I_C=100\text{mA}, V_{CE}=1\text{V}$	$h_{FE} (1)$	85	--	400	
	$I_C=500\text{mA}, V_{CE}=1\text{V}$	h_{FE}	40	--	--	
Collector-Emitter Saturation Voltage	$I_C=500\text{mA}, I_B=50\text{mA}$	$V_{CE(sat)}$	--	--	0.6	V
Base-Emitter Voltage	$V_{CE}=1\text{V}, I_C=10\text{mA}$	$V_{CE(sat)}$	--	0.8	1.0	V
Current-Gain-Bandwidth Product	$V_{CE}=5\text{V}, I_C=10\text{mA}$	f_T	100	120	--	MHz
Collector Output Capacitance	$V_{CB}=10\text{V}, I_E=0, f=1\text{MHz}$	C_{ob}	--	13	30	pF

■ DIMENSION

单位 (UNIT) : mm

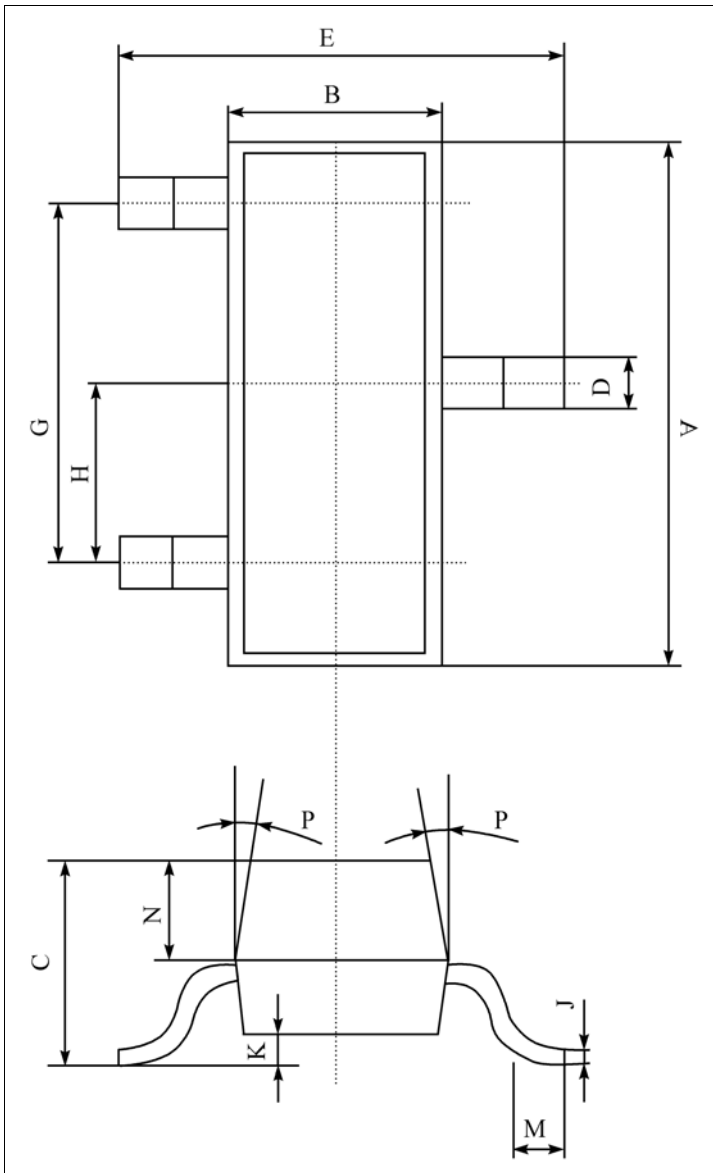

序号	数值及公差
A	2.90±0.10
B	1.30±0.10
C	1.00±0.10
D	0.40±0.10
E	2.40±0.20
G	1.90±0.10
H	0.95±0.05
J	0.13±0.05
K	0.00-0.10
M	≥0.20
N	0.60±0.10
P	7±2°
Packing SOT-23 包装规格 SMD片式表面贴封装 包装方式: 载带卷盘包装 Tape & Reel, 3Kpcs/Reel 每卷数量3000只 (3Kpcs/Reel) 每盒数量45000只 (45Kpcs/BOX) 每箱数量180000只 (180Kpcs/Cartons)	

SOT-23 Tape and reel

SOT-23 Embossed Carrier Tape

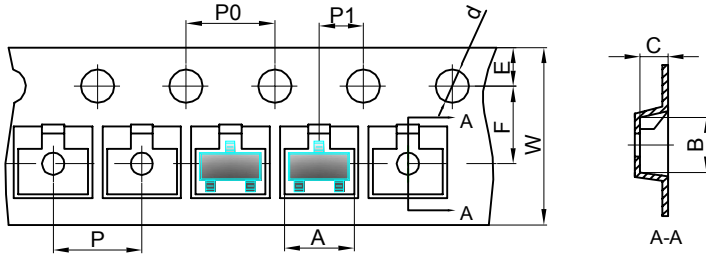

Dimensions are in millimeter										
Pkg type	A	B	C	d	E	F	P0	P	P1	W
SOT-23	3.15	2.77	1.22	Ø1.50	1.75	3.50	4.00	4.00	2.00	8.00

SOT-23 Tape Leader and Trailer

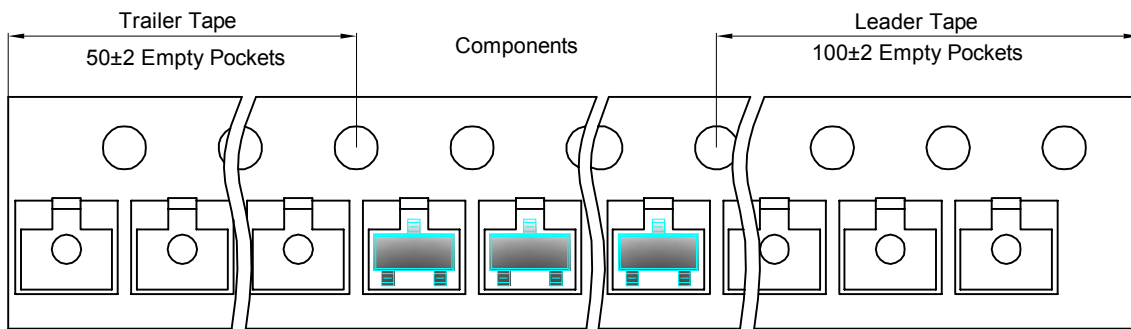

SOT-23 Reel

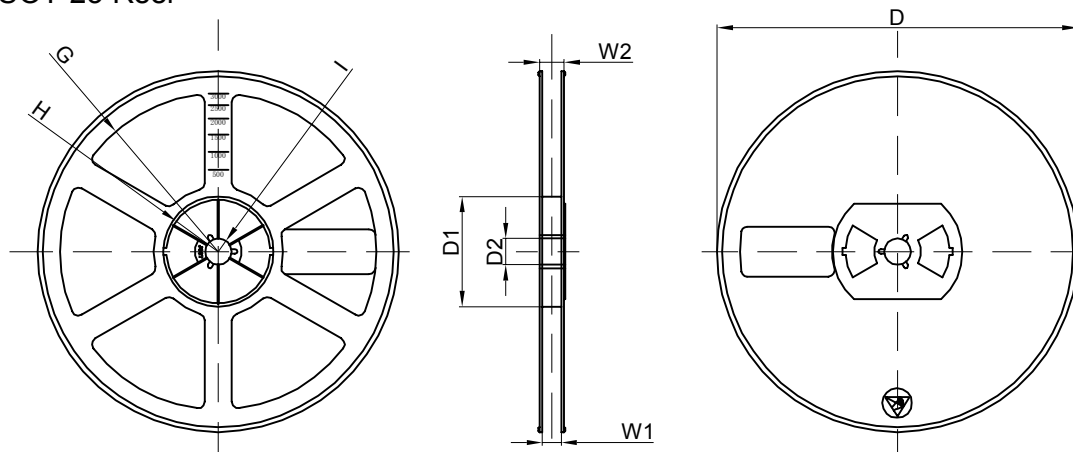

Dimensions are in millimeter								
Reel Option	D	D1	D2	G	H	I	W1	W2
7" Dia	Ø178.00	54.40	13.00	R78.00	R25.60	R6.50	9.50	12.30

REEL	Reel Size	Box	Box Size(mm)	Carton	Carton Size(mm)	G.W.(kg)
3000 pcs	7 inch	45,000 pcs	192×192×193	180,000 pcs	404×404×214	

X-ON Electronics

Largest Supplier of Electrical and Electronic Components

Click to view similar products for [Bipolar Transistors - BJT category](#):

Click to view products by [MOT manufacturer](#):

Other Similar products are found below :

[BC559C](#) [MCH4017-TL-H](#) [MMBT-2369-TR](#) [BC546/116](#) [NJVMJD148T4G](#) [NTE16](#) [NTE195A](#) [IMX9T110](#) [2N4401-A](#) [2N6728](#) [2SA1419T-TD-H](#) [2SB1204S-TL-E](#) [2SC5488A-TL-H](#) [FMC5AT148](#) [2N2369ADCSM](#) [2N2907A](#) [2N3904-NS](#) [2N5769](#) [2SC4618TLN](#) [CPH6501-TL-E](#) [US6T6TR](#) [BAX18/A52R](#) [BC556/112](#) [IMZ2AT108](#) [MMST8098T146](#) [MCH6102-TL-E](#) [BC846B-13-F](#) [2N3879](#) [30A02MH-TL-E](#) [NTE13](#) [NTE282](#) [NTE323](#) [NTE350](#) [NTE81](#) [JANTX2N2920L](#) [JANSR2N2907AUB](#) [CMLT3946EG TR](#) [SNSS40600CF8T1G](#) [CMLT3906EG TR](#) [GRP-DATA-JANS2N2907AUB](#) [GRP-DATA-JANS2N2222AUA](#) [MMDT3946FL3-7](#) [2N4240](#) [JANS2N3019](#) [MSB30KH-13](#) [2N2221AUB](#) [2SD1815T-TL-E](#) [2N6678](#) [2N2907Ae4](#) [JAN2N3507](#)