

MSKSEMI 美森科

SEMICONDUCTOR



ESD



TVS



TSS



MOV



GDT



PLED

74HC595D(MS)

产品规格手册

产品简介

74HC595 是一款 8 位 CMOS 移位寄存器。8 位并行输出端口为可控的三态输出，一个串行输出端口，可以实现多级芯片串行控制，组成 8n 位（n 为芯片数量）并行输出。

产品特点

- 低输入电流：≤1uA
- 可控的三态输出设计
- CMOS 串行输出，可用于多个设备的级联
- 低功耗：I_{cc}≤5.0 μA, @ VCC=6V
- 标准串行（SPI）接口
- 封装形式：SOP16

产品用途

- LED 数码管驱动
- 自动化工程控制
- 其它应用领域

封装形式和管脚功能定义

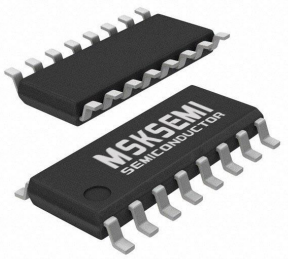
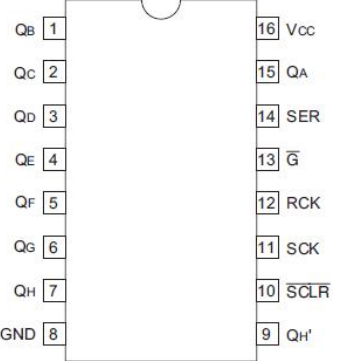
封装图	脚位信息
 <p>SOP-16</p>	

封装形式	SOP16	
管脚序号	管脚定义	功能说明
15	Q _A	Q _A ~Q _H 八位数据并行输出端
1~7	Q _B ~Q _G	
8	GND	电源地
9	Q' _H	串行数据输出管脚
10	$\overline{\text{SCLR}}$	移位寄存器清零端
11	SCK	数据输入时钟端
12	RCK	输出存储器锁存时钟端
13	$\overline{\text{G}}$	输出使能端
14	SER	数据输入端
16	VCC	电源端

真值表 (“↑” 表示上升沿；“↓” 表示下降沿)

输入管脚					输出管脚
SER	RCK	SCK	SCLR	-	
X	X	X	X	H	Q _A ~Q _H 输出端高阻态
X	X	X	X	L	Q _A ~Q _H 输出端输出有效值 L 或 H
X	X	X	L	L	移位寄存器清零，Q' _H =0
L	X	↑	H	L	移位寄存器存储 L 值，Q' _H 输出 Q _{n-1}
H	X	↑	H	L	移位寄存器存储 H 值，Q' _H 输出 Q _{n-1}
X	X	↓	H	L	移位寄存器状态保持不变
X	↑	X	H	L	8 位锁存移位寄存器中的状态值并行输出
X	↓	X	H	L	存储器输出状态保持不变

极限参数

参数	符号	极限值	单位
工作电压	V_{CC}	-0.5 to 6.5	V
输入/输出电压	V_{IN} 、 V_{OUT}	-0.5 to $V_{CC}+0.5$	V
输入/输出钳位电流	I_{IK} 、 I_{OK}	± 20	mA
输出电流	I_{OUT}	± 35	mA
VCC、GND 电流	I_{CC} 、 I_{GND}	± 70	mA
耗散功率	P_D	500	mW
工作温度	T_A	0-70	°C
存储温度	T_S	-65-150	°C
引脚焊接温度	T_W	260, 10s	°C

注：极限参数是指无论在任何条件下都不能超过的极限值。万一超过此极限值，将有可能造成产品劣化等物理性损伤；同时在接近极限参数下，不能保证芯片可以正常工作。

时序图

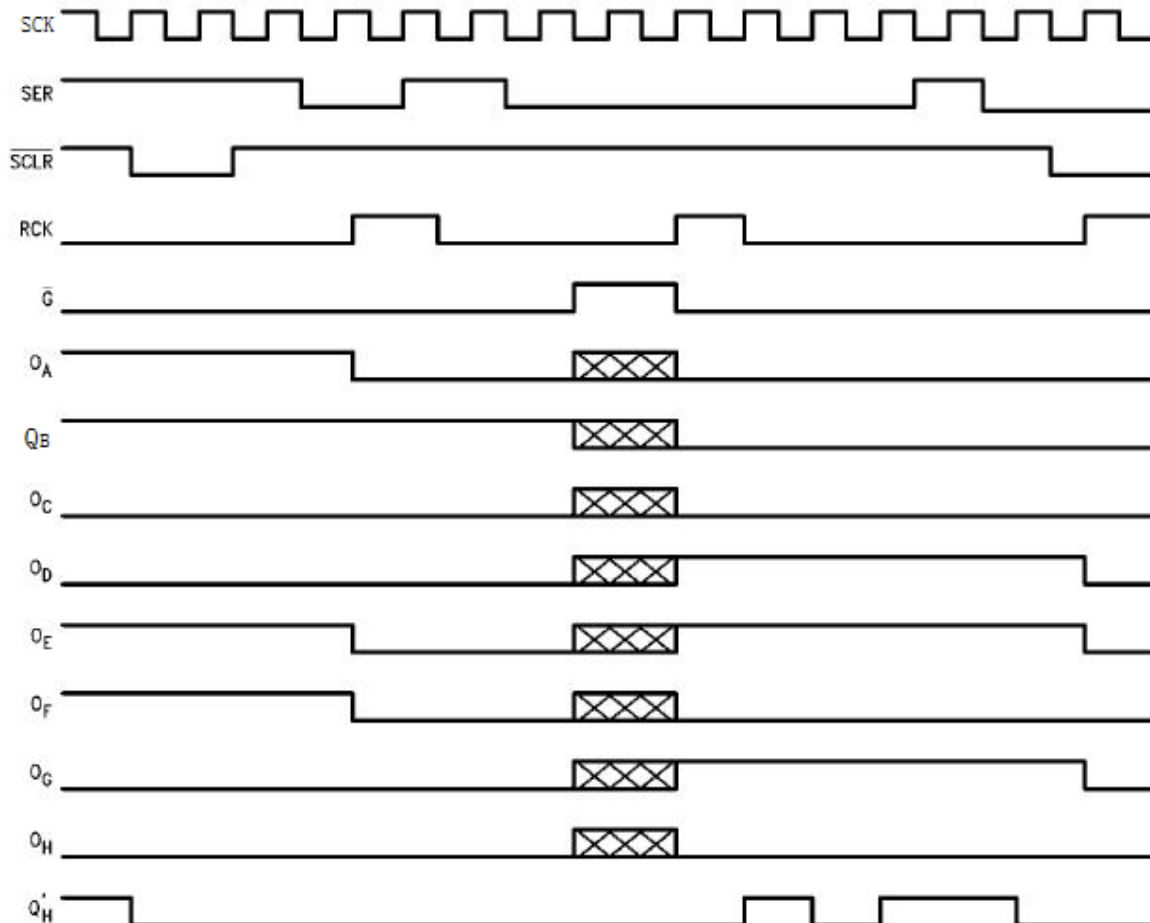

NOTE:  Implies that the output is in TRI-STATE mode.

原理逻辑图

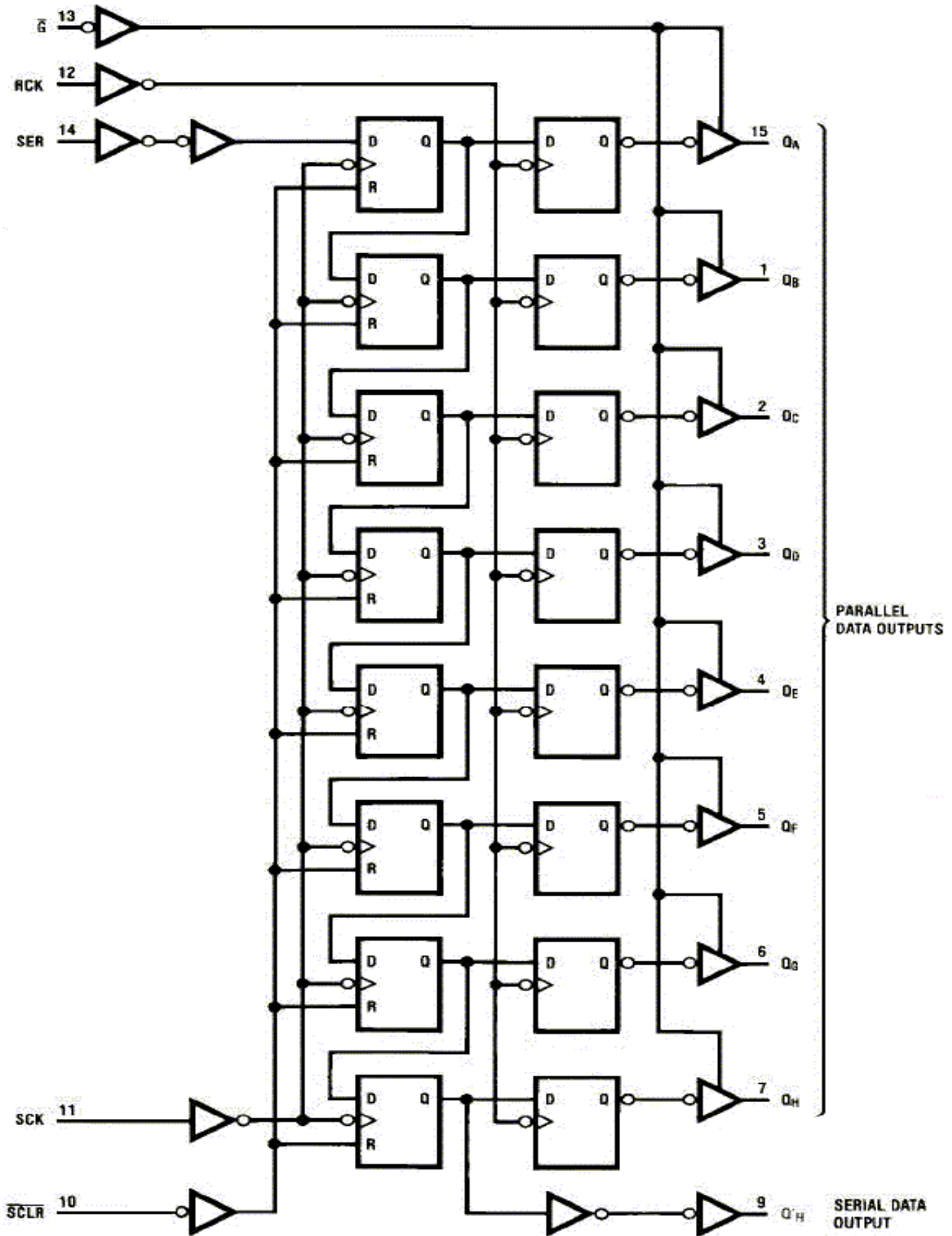

工作条件

项目	符号	最小值	典型值	最大值	单位
电源电压	V_{CC}	2	5	6	V
输入输出电压	V_{IN} 、 V_{out}	0		V_{CC}	V
输入上升/ 下降时间	t_r t_f	$V_{CC}=2.0V$	0	1000	ns
		$V_{CC}=4.5V$	0	500	ns
		$V_{CC}=6.0V$	0	400	ns

电学特性

 直流电学特性: $T_A=25^{\circ}C$

符号	项目		测试条件	$V_{CC}(V)$	最小值	典型值	最大值	单位	
V_{IH}	高电平有效输入电压			2.0	1.5			V	
				4.5	3.15			V	
				6.0	4.2			V	
V_{IL}	低电平有效输入电压			2.0			0.5	V	
				4.5			1.35	V	
				6.0			1.8	V	
V_{OH}	高电平输出电压	Q_A to Q_H Q'_H	$V_I = V_{IH}$ or V_{IL}	$I_{OH}=20\mu A$	2.0	1.9			V
					4.5	4.4			V
					6.0	5.9			V
		Q'_H		$I_{OH}=6.0mA$	4.5	3.9	4.3		V
				$I_{OH}=7.8mA$	6.0	5.2	5.8		V
				$I_{OH}=4.0mA$	4.5	3.9	4.2		V
V_{OL}	低电平输出电压	Q_A to Q_H Q'_H	$V_I = V_{IH}$ or V_{IL}	$I_{OH}=20\mu A$	2.0			0.1	V
					4.5			0.1	V
					6.0			0.1	V
		Q'_H		$I_{OH}=6.0mA$	4.5		0.2	0.4	V
				$I_{OH}=7.8mA$	6.0		0.25	0.4	V
				$I_{OH}=4.0mA$	4.5		0.2	0.5	V
		$I_{OH}=5.2mA$	6.0		0.15	0.5	V		
I_{OZ}	关闭状态输出电流		$V_{OUT}=V_{CC}$ or GND , $V_I=V_{IH}$ or V_{IL}	6.0			10	μA	
I_{IN}	输入电流		$V_I=V_{CC}$ or GND	6.0			1	μA	
I_{CC}	工作电流		$V_I=V_{CC}$ or GND , $I_{OUT}=0\mu A$	6.0			5	μA	
V_{CC}	工作电压				2		6	V	

交流电学特性: $T_a=25^{\circ}\text{C}$ $V_{CC}=5.0\text{V}$, $t_r=t_f \leq 20\text{ns}$ 见测试方法。

符号	项目	测试条件	最小值	典型值	最大值	单位
f_{Max}	SCK 最高工作频率			10		MHZ
t_{PHL} , t_{PLH}	传输延迟时间 SCK to Q'_H	$C_L=50\text{pF}$		100		ns
	传输延迟时间 RCK to Q_A thru Q_H	$C_L=50\text{pF}$		100		ns
	传输延迟时间 $\overline{\text{SCLR}}$ to Q'_H	$C_L=50\text{pF}$		50		ns
t_{ZH} , t_{ZL}	输出启用时间 to Q_A thru Q_H	$R_L=1\text{k}\Omega$ $C_L=50\text{pF}$		17		ns
t_{HZ} , t_{LZ}	输出禁用时间 to Q_A thru Q_H	$R_L=1\text{k}\Omega$ $C_L=50\text{pF}$		15		ns
t_{SU}	最小存储时间 SER to SCK			20		ns
t_{SU}	最小存储时间 SCK to RCK			20		ns
T_{rem}	最小清除时间 $\overline{\text{SCLR}}$ to SCK			10		ns
t_{W}	最小脉冲宽度 SCK or $\overline{\text{SCLR}}$			20		ns
t_{H}	最小保持时间 SER to SCK			5		ns
t_{TLH} , t_{THL}	输出上升/下降沿时间 Q_A thru Q_H , Q'_H			100		ns

■测试方法

1、接线图

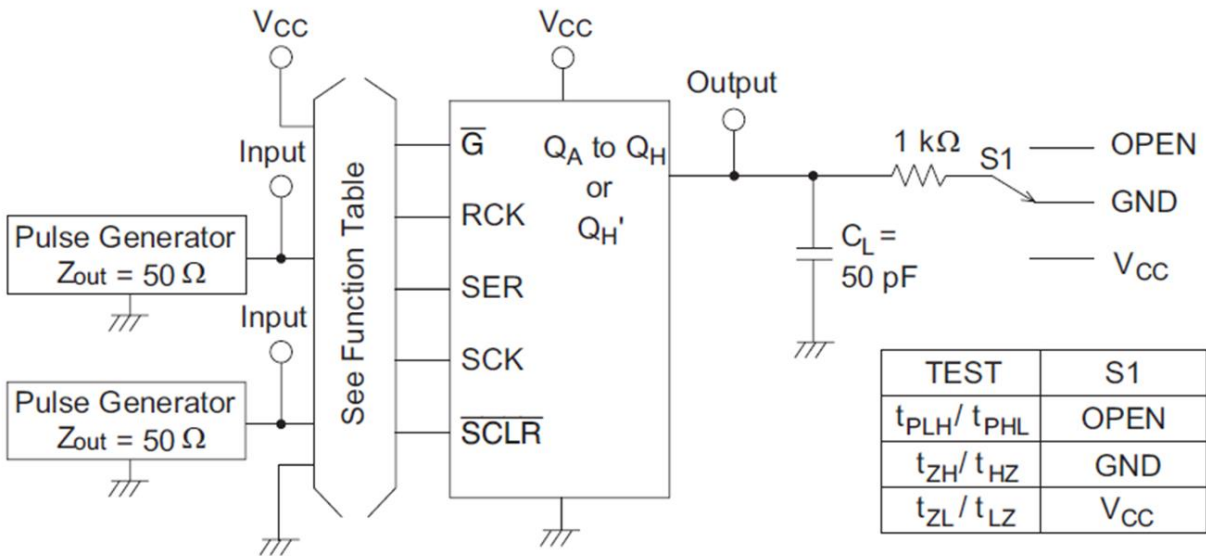

2、波形测量示意图

• Waveform – 1 (SCK to QH')

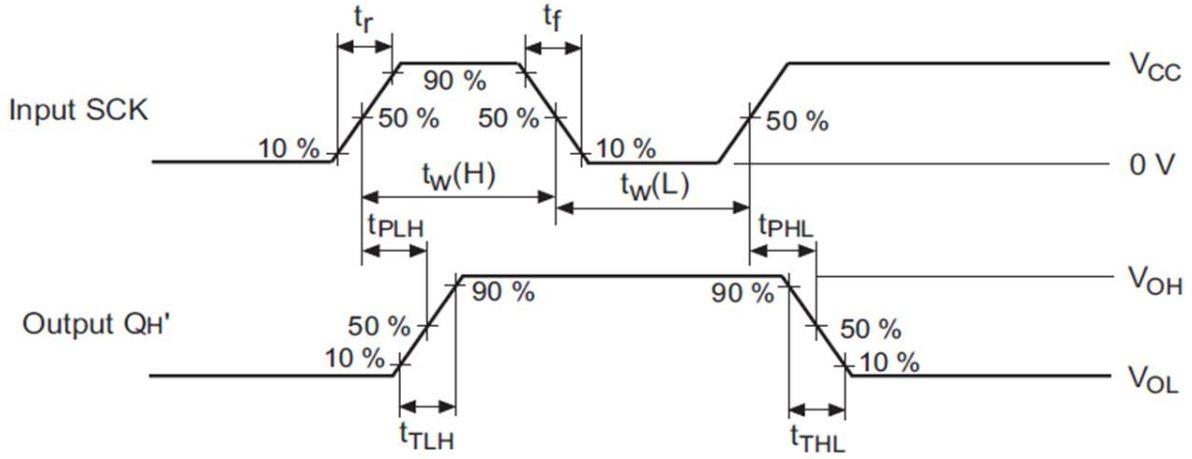

Note : 1. Input waveform : PRR \leq 1 MHz, duty cycle 50%

• Waveform – 2 (RCK to Q)

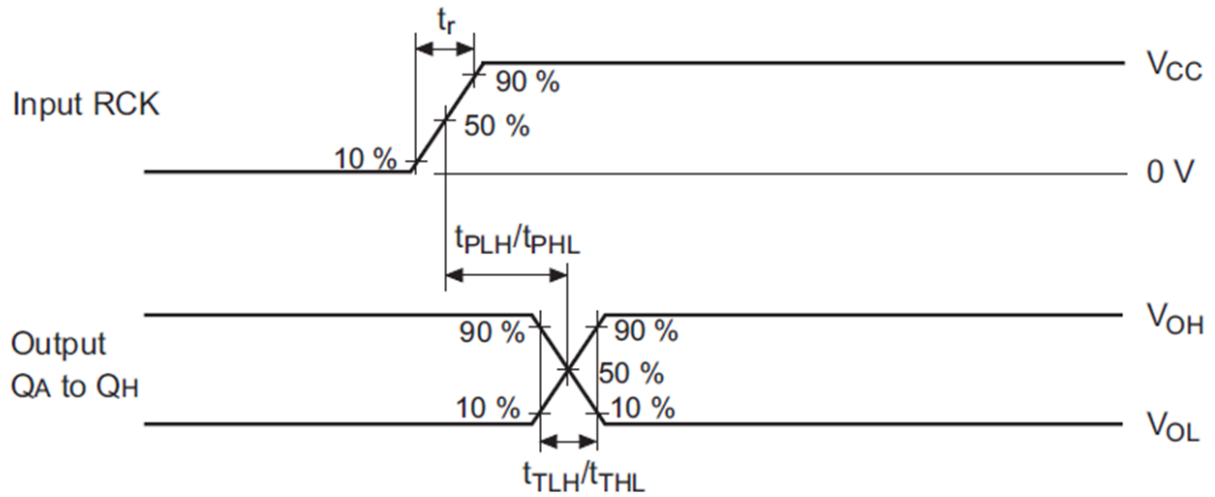

Note : 1. Input waveform : PRR \leq 1 MHz, duty cycle 50%

• Waveform – 3 ($\overline{\text{SCLR}}$ to QH')

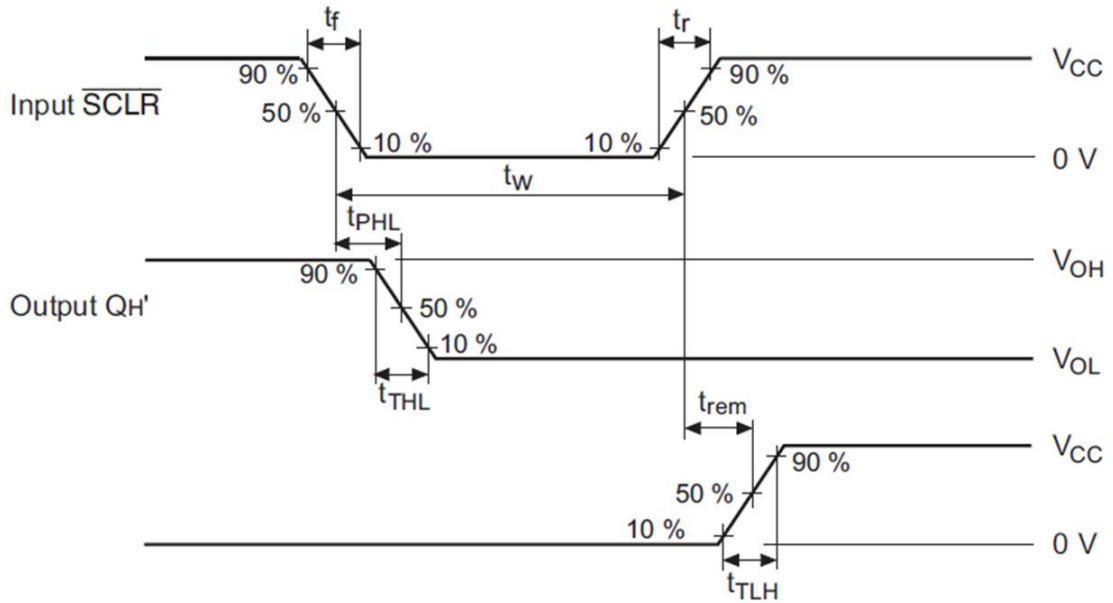

Note : 1. Input waveform : PRR \leq 1 MHz, duty cycle 50%

• Waveform – 4 (SER to SCK)

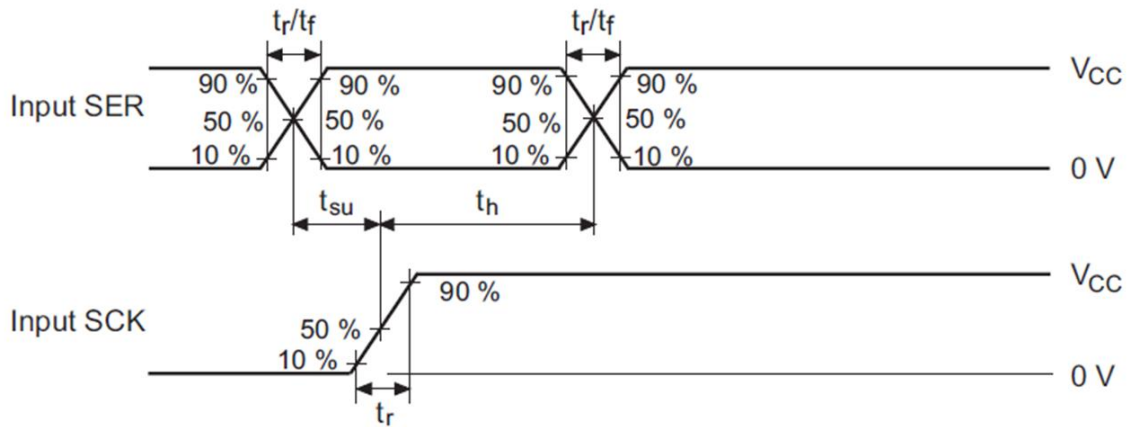

Note : 1. Input waveform : PRR \leq 1 MHz, duty cycle 50%

• Waveform – 5 (SCK to RCK)

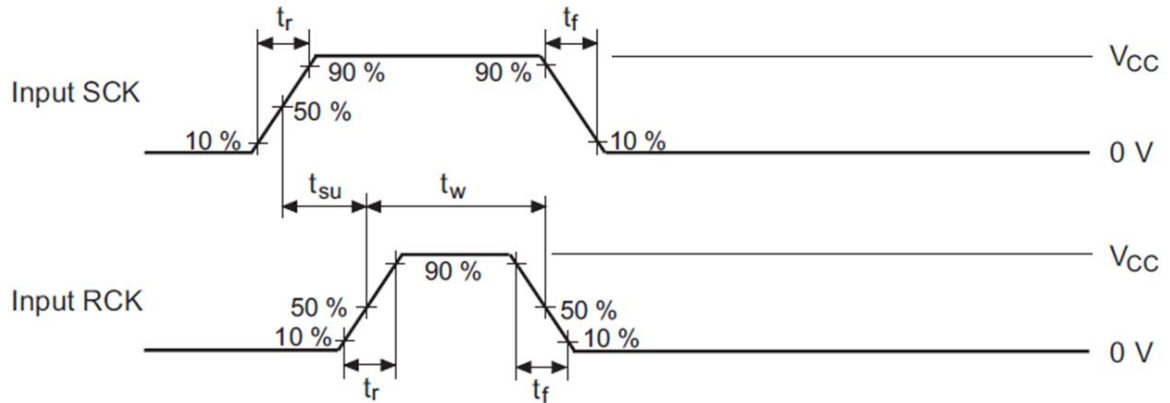

Note : 1. Input waveform : PRR ≤ 1 MHz, duty cycle 50%

• Waveform – 6 (t_{ZL}, t_{ZH}, t_{LZ}, t_{HZ})

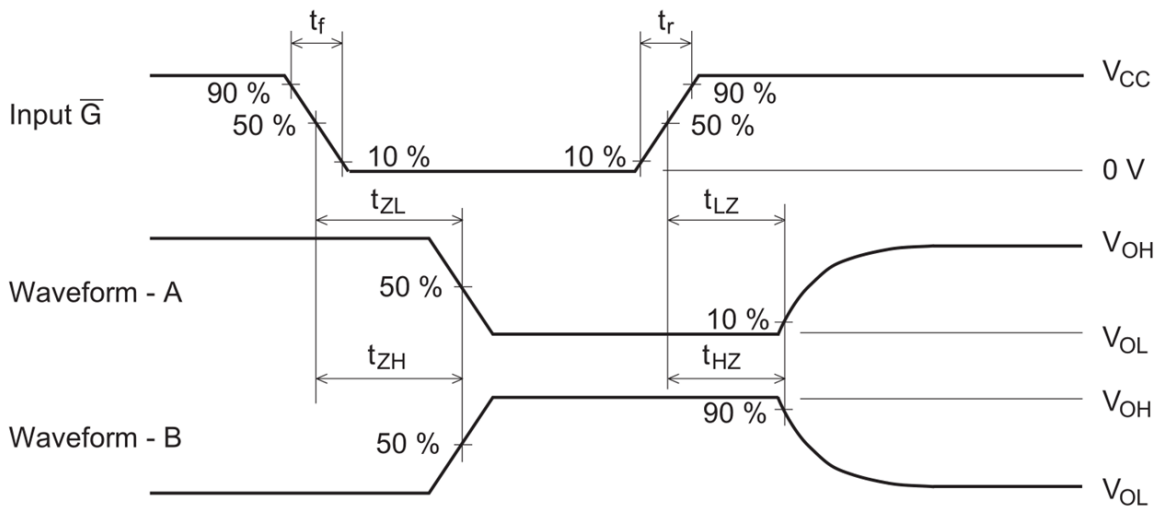

- Notes :
1. Input waveform : PRR ≤ 1 MHz, duty cycle 50%
 2. Waveform - A is for an output with internal conditions such that the output is low except when disabled by the output control.
 3. Waveform - B is for an output with internal conditions such that the output is high except when disabled by the output control.
 4. The output are measured one at a time with one transition per measurement.

SOP-16 包装数据

单位：毫米 / 英寸

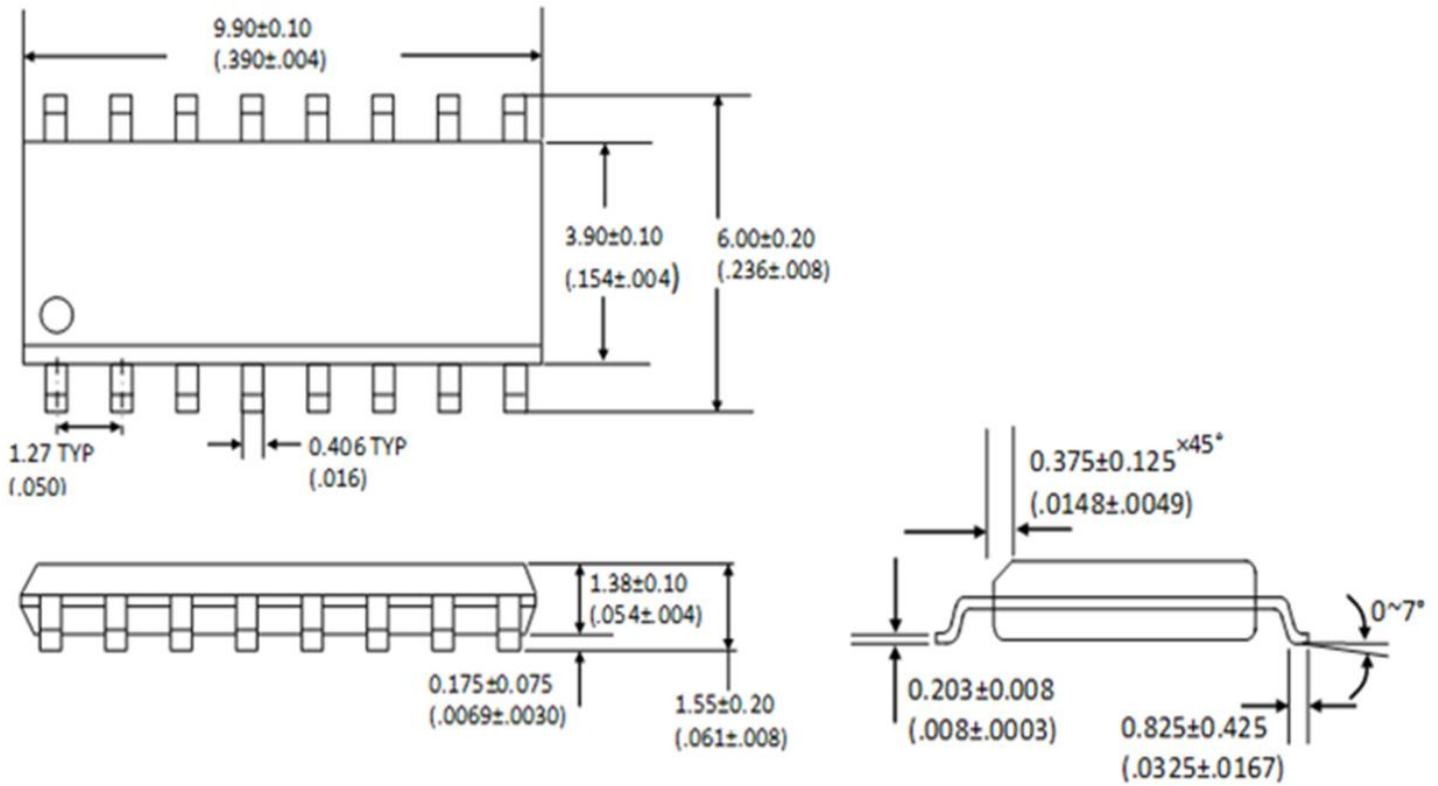

卷轴规格

P/N	PKG	QTY
74HC595D(MS)	SOP-16	2500

Attention

■ Any and all MSKSEMI Semiconductor products described or contained herein do not have specifications that can handle applications that require extremely high levels of reliability, such as life-support systems, aircraft's control systems, or other applications whose failure can be reasonably expected to result in serious physical and/or material damage. Consult with your MSKSEMI Semiconductor representative nearest you before using any MSKSEMI Semiconductor products described or contained herein in such applications.

■ MSKSEMI Semiconductor assumes no responsibility for equipment failures that result from using products at values that exceed, even momentarily, rated values (such as maximum ratings, operating condition ranges, or other parameters) listed in products specifications of any and all MSKSEMI Semiconductor products described or contained herein.

■ Specifications of any and all MSKSEMI Semiconductor products described or contained herein stipulate the performance, characteristics, and functions of the described products in the independent state, and are not guarantees of the performance, characteristics, and functions of the described products as mounted in the customer's products or equipment. To verify symptoms and states that cannot be evaluated in an independent device, the customer should always evaluate and test devices mounted in the customer's products or equipment.

■ MSKSEMI Semiconductor strives to supply high-quality high-reliability products. However, any and all semiconductor products fail with some probability. It is possible that these probabilistic failures could give rise to accidents or events that could endanger human lives, that could give rise to smoke or fire, or that could cause damage to other property. When designing equipment, adopt safety measures so that these kinds of accidents or events cannot occur. Such measures include but are not limited to protective circuits and error prevention circuits for safe design, redundant design, and structural design.

■ In the event that any or all MSKSEMI Semiconductor products (including technical data, services) described or contained herein are controlled under any of applicable local export control laws and regulations, such products must not be exported without obtaining the export license from the authorities concerned in accordance with the above law.

■ No part of this publication may be reproduced or transmitted in any form or by any means, electronic or mechanical, including photocopying and recording, or any information storage or retrieval system, or otherwise, without the prior written permission of MSKSEMI Semiconductor.

■ Information (including circuit diagrams and circuit parameters) herein is for example only ; it is not guaranteed for volume production. MSKSEMI Semiconductor believes information herein is accurate and reliable, but no guarantees are made or implied regarding its use or any infringement of intellectual property rights or other rights of third parties.

■ Any and all information described or contained herein are subject to change without notice due to product/technology improvement, etc. When designing equipment, refer to the "Delivery Specification" for the MSKSEMI Semiconductor product that you intend to use.

X-ON Electronics

Largest Supplier of Electrical and Electronic Components

Click to view similar products for [Counter Shift Registers](#) category:

Click to view products by [MSKSEMI](#) manufacturer:

Other Similar products are found below :

[CD4031BE](#) [CD4034BE](#) [NLV74HC165ADTR2G](#) [5962-9172201M2A](#) [MC100EP142MNG](#) [MC100EP016AMNG](#) [MC74LV594ADR2G](#)
[NLV14094BDTR2G](#) [NLV74HC589ADR2G](#) [AiP74HC595TA16.TR](#) [SN74LS295BN](#) [AIP74HC164TA14.TR](#) [TM74HC164](#) [74HC164D](#)
[AiP74HC165SA16.TR](#) [74HC573D](#) [AiP74HC165TA16.TR](#) [XL74HC597-TS](#) [74HC164MT/TR](#) [XL74HC595TS](#) [74HC595DMT/TR](#)
[CD4094DMT/TR](#) [74HC595D\(MS\)](#) [CD4094DM/TR](#) [74HC164D](#) [GN165D](#) [74HC595DM/TR](#) [AIP74HC595SA.TR](#) [XL4021B](#)
[74HC164D\(MS\)](#) [74HC595MT/TR](#) [XL74HC165-TS](#) [74HC595D](#) [74HC595D](#) [74HC595D.](#) [74HCT595BQ](#) [Aip74HC595SA16.TR](#)
[SN74LS164DR-HXY](#) [74HC164DR](#) [RS595SXS16](#) [74HC165-HXY](#) [74HC595E](#) [RS164XQ](#) [GN74HC595D](#) [74HC164DRG](#) [XD74HC165](#)
[SN74LV165AQWBQBRQ1](#) [AiP74HC4094SA16.TR](#) [HX74HC595IDRG](#) [CD4094DN](#)