

# MSKSEMI 美森科

SEMICONDUCTOR



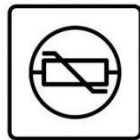
ESD



TVS



TSS



MOV



GDT



PLED

## AONR21321-MS

---

Product specification

## Description

The AONR21321-MS uses advanced trench technology excellent  $R_{DS(ON)}$ , low gate charge and operation with gate voltages as low as 4.5V. This device is suitable for use as a load switch or in PWM applications.

## Features

$V_{DS} = -30V, I_D = -50A$

$R_{DS(ON)} < 25m\Omega @ V_{GS} = -4.5V$

$R_{DS(ON)} < 15m\Omega @ V_{GS} = -10V$

High Power and current handling capability

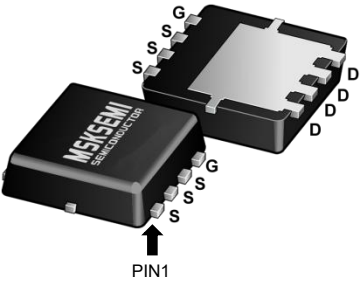
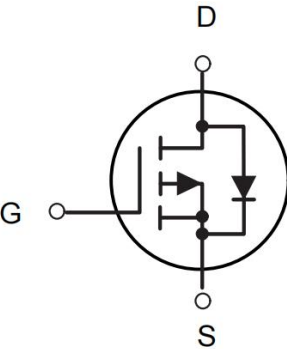

Lead free product is acquired

Surface mount package

## Application

- PWM applications
- Load switch
- Power management

## Reference News

PACKAGE OUTLINE	P-Channel MOSFET	Marking
 <p>DFN5X6-8L</p>		

## Absolute Maximum Ratings (TA=25°C unless otherwise noted)

Symbol	Parameter	Limit	Unit
V <sub>DS</sub>	Drain-Source Voltage	-30	V
V <sub>GS</sub>	Gate-Source Voltage	±20	V
I <sub>D</sub>	Drain Current-Continuous (T <sub>c</sub> =25 °C)	-50	A
	Drain Current-Continuous (T <sub>c</sub> =100 °C)	-24	
I <sub>DM</sub>	Drain Current-Pulsed (Note 1)	-80	A
P <sub>D</sub>	Maximum Power Dissipation (T <sub>c</sub> =25 °C)	3	W
	Maximum Power Dissipation (T <sub>c</sub> =100 °C)	1.3	
EAS	Single pulse avalanche energy (Note 5)	231	mJ
T <sub>J</sub> , T <sub>STG</sub>	Operating Junction and Storage Temperature Range	-55 To 150	°C
R <sub>θJA</sub>	Thermal Resistance, Junction-to-Ambient (Note 2)	41.67	°C/ W

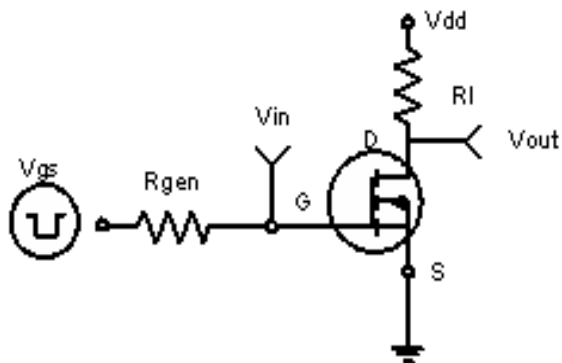
**Electrical Characteristics (TA=25°C unless otherwise noted)**

Parameter	Symbol	Condition	Min	Typ	Max	Unit
Drain- Source Breakdown Voltage	BV <sub>DSS</sub>	V <sub>GS</sub> =0V I <sub>D</sub> =-250μA	-30	-33	-	V
Zero Gate Voltage Drain Current	IDSS	V <sub>DS</sub> =-30V, V <sub>GS</sub> =0V	-	-	-1	μA
Gate- Body Leakage Current	IGSS	V <sub>GS</sub> =±20V, V <sub>DS</sub> =0V	-	-	±100	nA
Gate Threshold Voltage	VGS(th)	V <sub>DS</sub> =V <sub>GS</sub> , I <sub>D</sub> =-250μA	-1	-1.5	-3	V
Drain- Source On- State Resistance	RDS(ON)	V <sub>GS</sub> =-10V, I <sub>D</sub> =-10A	-	9	15	mΩ
		V <sub>GS</sub> =-4.5V, I <sub>D</sub> =-7A	-	18	25	mΩ
Forward Transconductance	gFS	V <sub>DS</sub> =-10V, I <sub>D</sub> =-10A	-	20	-	S
Input Capacitance	C <sub>iss</sub>	V <sub>DS</sub> =-15V, V <sub>GS</sub> =0V, F=1.0MHz	-	1750	-	PF
Output Capacitance	C <sub>oss</sub>		-	215	-	PF
Reverse Transfer Capacitance	C <sub>rss</sub>		-	180	-	PF
Turn-on Delay Time	td(on)	V <sub>DD</sub> =-15V, I <sub>D</sub> =-10A, V <sub>GS</sub> =-10V, R <sub>GEN</sub> =1 Ω	-	9	-	nS
Turn-on Rise Time	t <sub>r</sub>		-	8	-	nS
Turn-Off Delay Time	td(off)		-	28	-	nS
Turn-Off Fall Time	t <sub>f</sub>		-	10	-	nS
Total Gate Charge	Q <sub>g</sub>	V <sub>DS</sub> =-15V, I <sub>D</sub> =-10A, V <sub>GS</sub> =-10V	-	24	-	nC
Gate- Source Charge	Q <sub>gs</sub>		-	3.5	-	nC
Gate- Drain Charge	Q <sub>gd</sub>		-	6	-	nC
Diode Forward Current (Note 2)	I <sub>S</sub>		-	-	-12	A
Diode Forward Voltage (Note 3)	VSD	V <sub>GS</sub> =0V, I <sub>S</sub> =-12A	-	-	-1.2	V

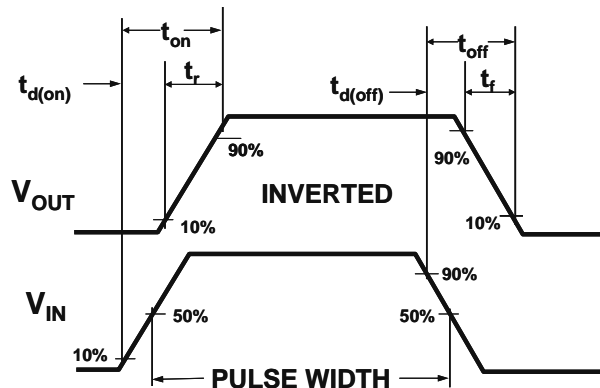
**Notes:**

1. Repetitive Rating: Pulse width limited by maximum junction temperature .
2. Surface Mounted on FR4 Board, t ≤ 10 sec .
3. Pulse Test: Pulse Width ≤ 300μs, Duty Cycle ≤ 2% .
4. Guaranteed by design, not subject to production
5. E<sub>AS</sub> condition: T<sub>j</sub>=25C, V<sub>DD</sub>=- 15V, V<sub>G</sub>=10V, L=0 .5mH, R<sub>g</sub>=25Ω, I<sub>AS</sub>=-34A

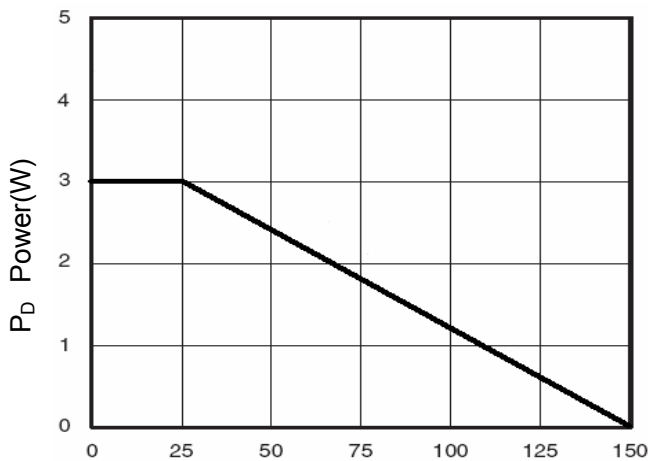
**Typical Electrical and Thermal Characteristics**



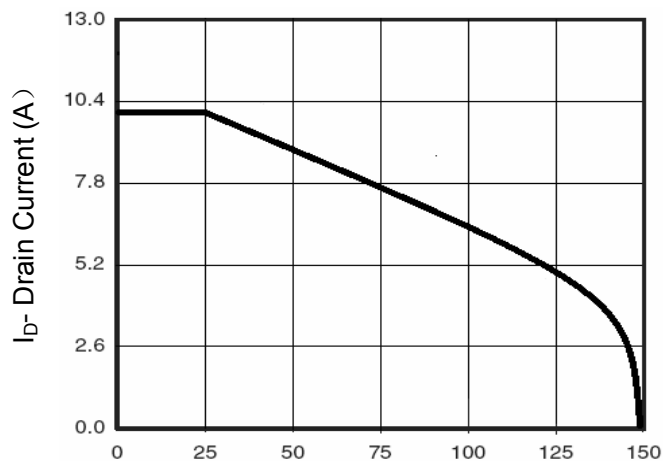
**Figure 1: Switching Test Circuit**



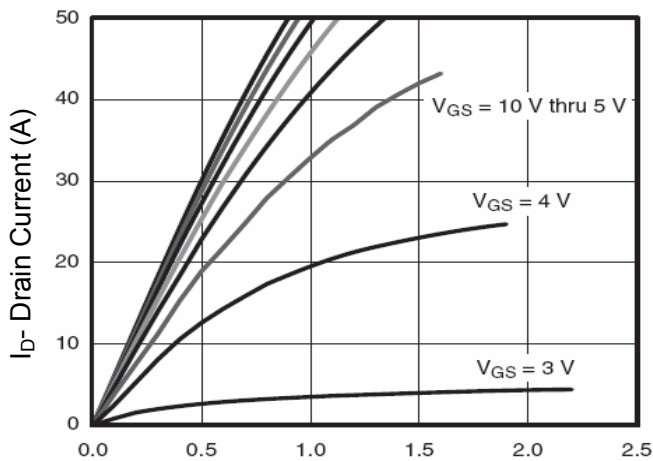
**Figure 2: Switching Waveforms**



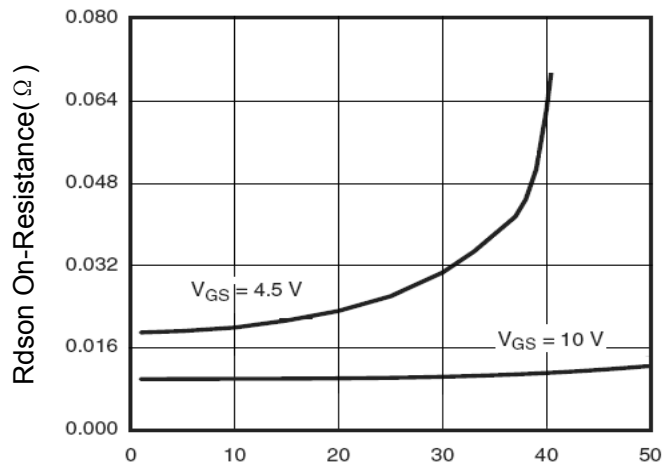
T<sub>J</sub>-Junction Temperature(°C)  
**Figure 3 Power Dissipation**



T<sub>J</sub>-Junction Temperature(°C)  
**Figure 4 Drain Current**

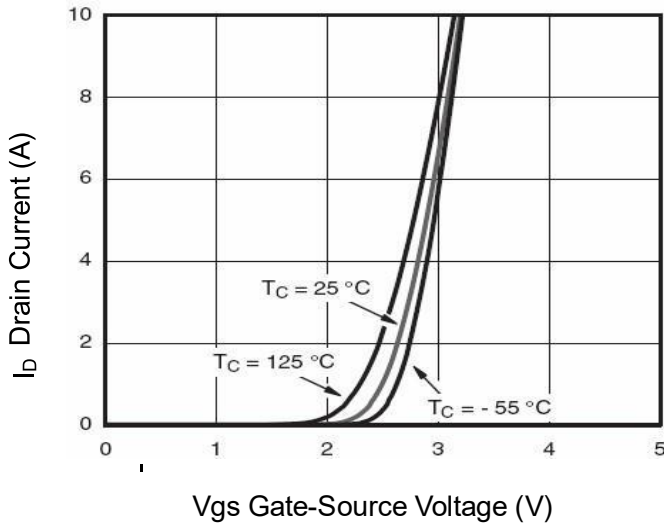


V<sub>ds</sub> Drain-Source Voltage (V)  
**Figure 5 Output Characteristics**

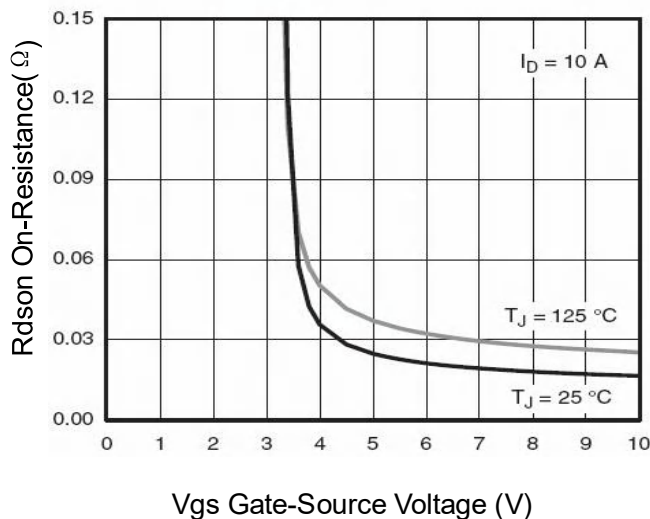


I<sub>D</sub>- Drain Current (A)  
**Figure 6 Drain-Source On-Resistance**

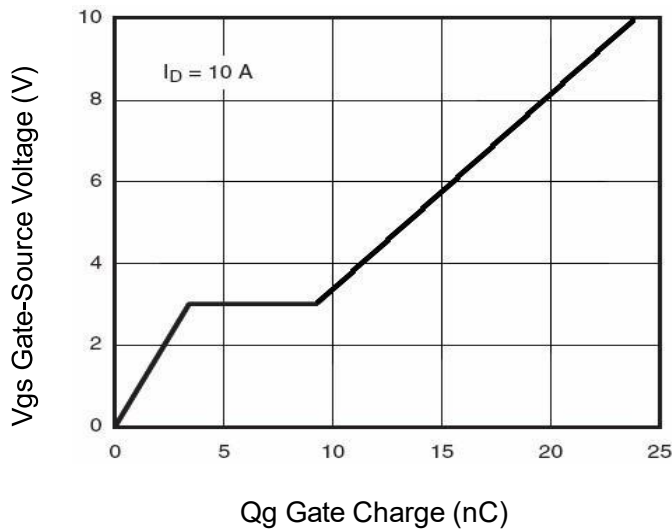
**Figure 5 Output Characteristics**



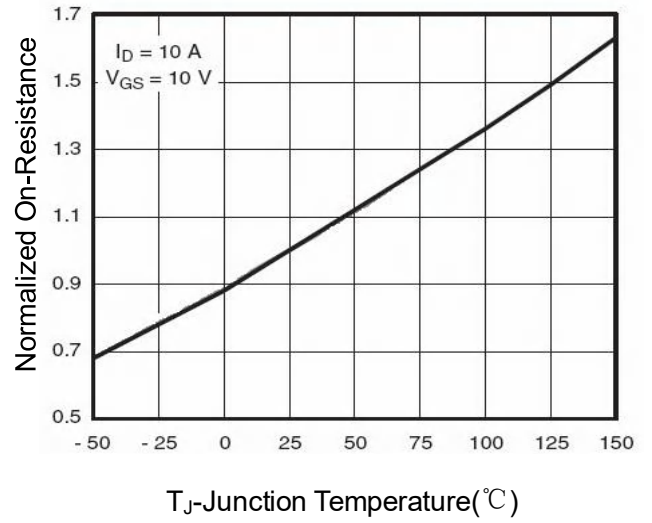
**Figure 7 Transfer Characteristics**



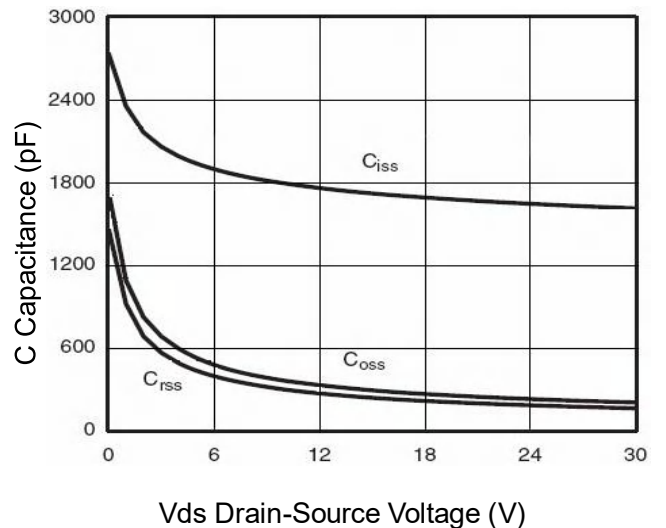
**Figure 9 Rdson vs Vgs**



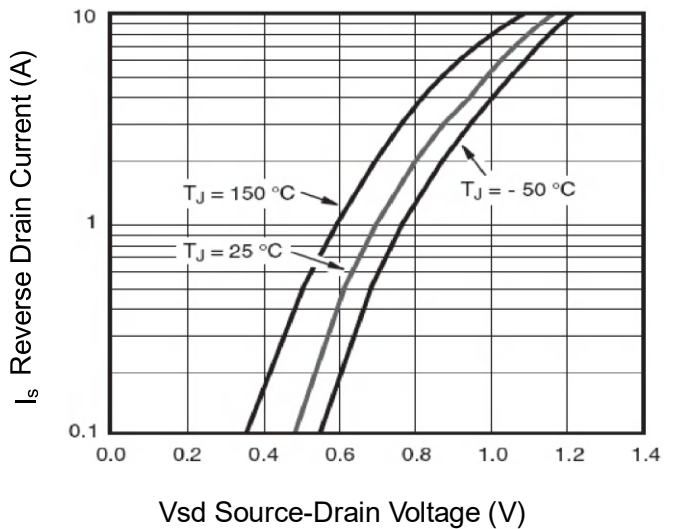
**Figure 11 Gate Charge**



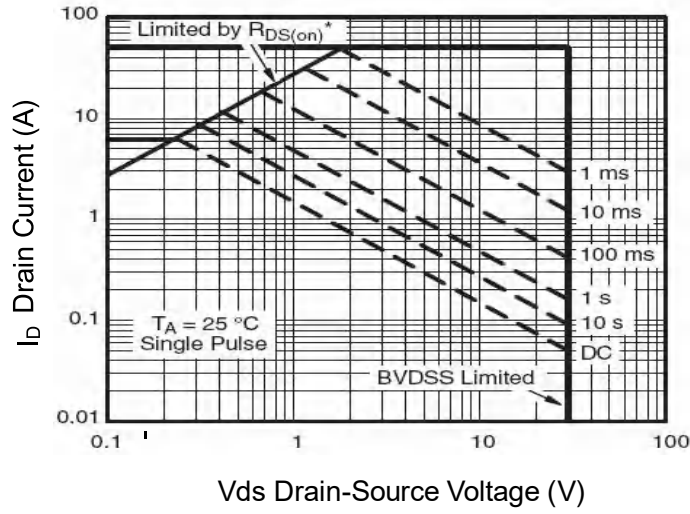
**Figure 8 Drain-Source On-Resistance**



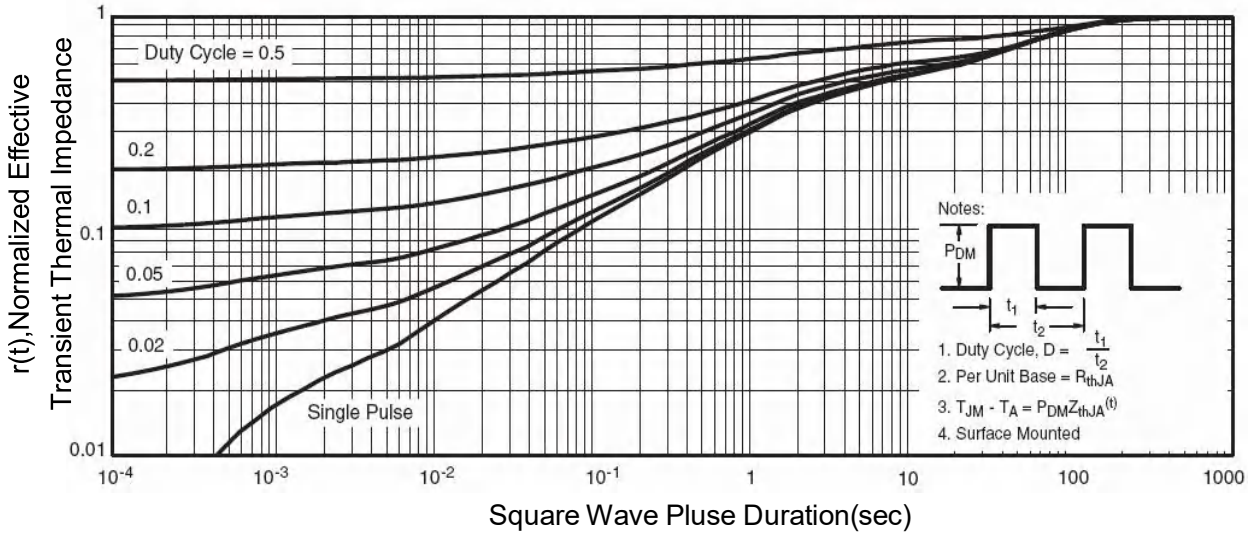
**Figure 10 Capacitance vs Vds**



**Figure 12 Source- Drain Diode Forward**

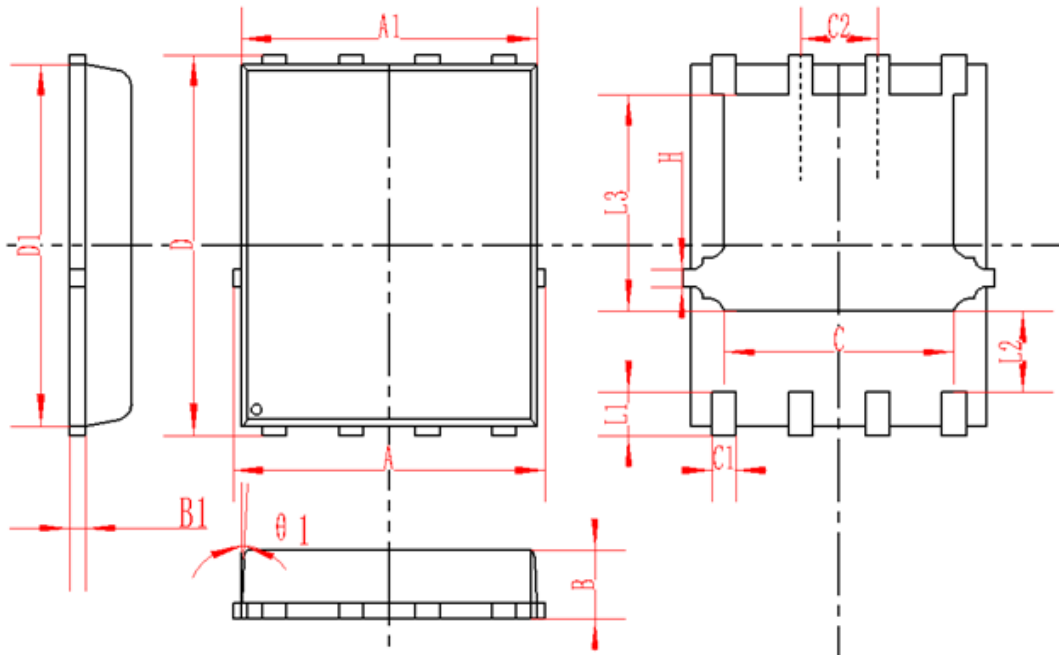


**Figure 13 Safe Operation Area**



**Figure 14 Normalized Maximum Transient Thermal Impedance**

**DFN5X6-8L Package Information**



SYMBOL	MM			INCH		
	MIN	NOM	MAX	MIN	NOM	MAX
A	4.95	5	5.05	0.195	0.197	0.199
A1	4.82	4.9	4.98	0.190	0.193	0.196
D	5.98	6	6.02	0.235	0.236	0.237
D1	5.67	5.75	5.83	0.223	0.226	0.230
B	0.9	0.95	1	0.035	0.037	0.039
B1	0.254REF			0.010REF		
C	3.95	4	4.05	0.156	0.157	0.159
C1	0.35	0.4	0.45	0.014	0.016	0.018
C2	1.27TYP			0.5TYP		
θ1	8°	10°	12°	8°	10°	12°
L1	0.63	0.64	0.65	0.025	0.025	0.026
L2	1.2	1.3	1.4	0.047	0.051	0.055
L3	3.415	3.42	3.425	0.134	0.135	0.135
H	0.24	0.25	0.26	0.009	0.010	0.010

**REEL SPECIFICATION**

P/N	PKG	QTY
AONR21321-MS	DFN5X6-8L	5000

## Attention

- Any and all MSKSEMI Semiconductor products described or contained herein do not have specifications that can handle applications that require extremely high levels of reliability, such as life-support systems, aircraft's control systems, or other applications whose failure can be reasonably expected to result in serious physical and/or material damage. Consult with your MSKSEMI Semiconductor representative nearest you before using any MSKSEMI Semiconductor products described or contained herein in such applications.
- MSKSEMI Semiconductor assumes no responsibility for equipment failures that result from using products at values that exceed, even momentarily, rated values (such as maximum ratings, operating condition ranges, or other parameters) listed in products specifications of any and all MSKSEMI Semiconductor products described or contained herein.
- Specifications of any and all MSKSEMI Semiconductor products described or contained herein stipulate the performance, characteristics, and functions of the described products in the independent state, and are not guarantees of the performance, characteristics, and functions of the described products as mounted in the customer's products or equipment. To verify symptoms and states that cannot be evaluated in an independent device, the customer should always evaluate and test devices mounted in the customer's products or equipment.
- MSKSEMI Semiconductor strives to supply high-quality high-reliability products. However, any and all semiconductor products fail with some probability. It is possible that these probabilistic failures could give rise to accidents or events that could endanger human lives, that could give rise to smoke or fire, or that could cause damage to other property. When designing equipment, adopt safety measures so that these kinds of accidents or events cannot occur. Such measures include but are not limited to protective circuits and error prevention circuits for safe design, redundant design, and structural design.
- In the event that any or all MSKSEMI Semiconductor products (including technical data, services) described or contained herein are controlled under any of applicable local export control laws and regulations, such products must not be exported without obtaining the export license from the authorities concerned in accordance with the above law.
- No part of this publication may be reproduced or transmitted in any form or by any means, electronic or mechanical, including photocopying and recording, or any information storage or retrieval system, or otherwise, without the prior written permission of MSKSEMI Semiconductor.
- Information (including circuit diagrams and circuit parameters) herein is for example only ; it is not guaranteed for volume production. MSKSEMI Semiconductor believes information herein is accurate and reliable, but no guarantees are made or implied regarding its use or any infringements of intellectual property rights or other rights of third parties.
- Any and all information described or contained herein are subject to change without notice due to product/technology improvement, etc. When designing equipment, refer to the "Delivery Specification" for the MSKSEMI Semiconductor product that you intend to use.



## X-ON Electronics

Largest Supplier of Electrical and Electronic Components

*Click to view similar products for [MOSFET](#) category:*

*Click to view products by [MSKSEMI](#) manufacturer:*

Other Similar products are found below :

[IRFD120](#) [JANTX2N5237](#) [2SK2267\(Q\)](#) [BUK455-60A/B](#) [TK100A10N1,S4X\(S](#) [MIC4420CM-TR](#) [VN1206L](#) [NDP4060](#) [SI4482DY](#)  
[IRS2092STRPBF-EL](#) [IPS70R2K0CEAKMA1](#) [TK31J60W5,S1VQ\(O](#) [TK31J60W,S1VQ\(O](#) [TK16J60W,S1VQ\(O](#) [2SK2614\(TE16L1,Q\)](#)  
[DMN1017UCP3-7](#) [EFC2J004NUZTDG](#) [P85W28HP2F-7071](#) [DMN1053UCP4-7](#) [NTE2384](#) [DMC2700UDMQ-7](#) [DMN2080UCB4-7](#)  
[DMN61D9UWQ-13](#) [US6M2GTR](#) [DMN31D5UDJ-7](#) [DMP22D4UFO-7B](#) [IPS60R3K4CEAKMA1](#) [DMN1006UCA6-7](#) [DMN16M9UCA6-7](#)  
[STF5N65M6](#) [IRF40H233XTMA1](#) [STU5N65M6](#) [DMN6022SSD-13](#) [DMN13M9UCA6-7](#) [DMTH10H4M6SPS-13](#) [IPS60R360PFD7SAKMA1](#)  
[DMN2990UFB-7B](#) [SSM3K35CT,L3F](#) [IPLK60R1K0PFD7ATMA1](#) [2N7002W-G](#) [MCAC30N06Y-TP](#) [IPWS65R035CFD7AXKSA1](#)  
[MCQ7328-TP](#) [SSM3J143TU,LXHF](#) [DMN12M3UCA6-7](#) [PJMF280N65E1\\_T0\\_00201](#) [PJMF380N65E1\\_T0\\_00201](#)  
[PJMF280N60E1\\_T0\\_00201](#) [PJMF600N65E1\\_T0\\_00201](#) [PJMF900N65E1\\_T0\\_00201](#)