

MSKSEMI 美森科

SEMICONDUCTOR



ESD



TVS



TSS



MOV



GDT



PLED

LMV331IDBVR(MS)\LMV393IDR(MS)

Product specification

GENERAL DESCRIPTION

The LMV331IDBVR(MS) and LMV393IDR(MS) is the single and dual comparator version, and both are open-drain output comparators for maximum flexibility. It can operate from 2.1V to 5.5V, and have low power consuming 50µA (TYP) per channel at output low.

The LMV331IDBVR(MS) , LMV393IDR(MS) are the most cost-effective solutions for applications where low voltage operation, low power and space saving are the primary specifications in circuit design for portable consumer products.

The LMV331-MS, LMV393-MS are available in Green SOT-23-5, SOP-8 packages. It operates over an ambient temperature range of -40°C to +85°C.





FEATURES

- Supply Range: +2.1V to +5.5V
- Low Supply Current
- 50µA (TYP) per channel at VS = 5V and output low
- Input Common-Mode Voltage Range Includes Ground
- Low Output Saturation Voltage 100mV Typical
- Open-Drain Output for Maximum Flexibility
- SPECIFIED UP TO +125°C
- Micro SIZE PACKAGES: SOT23-5,SOP-8

APPLICATIONS

- Hysteresis Comparators
- Oscillators
- Window Comparators
- Industrial Equipment
- Test and Measurement

Reference News

PACKAGE OUTLINE	Marking
 SOT-23-5	 LMV331IDBVR(MS)
 SOP-8	 LMV393IDR(MS)

SIMPLIFIED SCHEMATIC

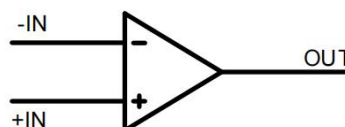

Figure 1. Simplified Schematic

Absolute Maximum Ratings⁽¹⁾

		MIN	MAX	UNIT
Voltage	Supply, $V_s=(V+) - (V-)$		7	V
	Input pin (IN+, IN-) ⁽²⁾	(V-) - 0.3	(V+) + 0.3	V
	Signal output pin ⁽³⁾	(V-) - 0.3	(V+) + 0.3	V
Current	Signal Input pin (IN+, IN-) ⁽²⁾	-10	10	mA
	Signal output pin ⁽³⁾	-55	55	mA
Temperature	Operating Range	-40	85	°C
	Storage	-65	150	°C
	Junction		150	°C

(1) Stresses above these ratings may cause permanent damage. Exposure to absolute maximum conditions for extended periods may degrade device reliability. These are stress ratings only, and functional operation of the device at these or any other conditions beyond those specified is not implied.

(2) Output terminals are diode-clamped to the power-supply rails. Output signals that can swing more than 0.5V beyond the supply rails should be current-limited to $\pm 55\text{mA}$ or less.

(3) Short-circuit from output to VCC can cause excessive heating and eventual destruction.

ESD Ratings

			VALUE	UNIT
$V_{(ESD)}$	Electrostatic discharge	Human-body model (HBM), per ANSI/ESDA/JEDEC JS-001, all pins ⁽¹⁾	± 2000	V
		Charged device model (CDM), per JEDEC specification JESD22-C101, all pins ⁽²⁾	± 1000	V

(1) JEDEC document JEP155 states that 500V HBM allows safe manufacturing with a standard ESD control process.

(2) JEDEC document JEP157 states that 250V CDM allows safe manufacturing with a standard ESD control process.

Recommended Operating Conditions

		MIN	MAX	UNIT
Supply voltage , $V_s= (V+) - (V-)$	Single-supply	2.1	5.5	V
	Dual-supply	± 0.9	± 2.75	V

PACKAGE/ORDER INFORMATION

MODEL	OPERATING TEMPERATURE RANGE	PACKAE DESCRIPTION	QTY
LMV331IDBVR(MS)	-40°C~85°C	SO-T23-5	3000
LMV393IDR(MS)	-40°C~85°C	SOP-8	2500

Pin Configuration and Functions (Top View)

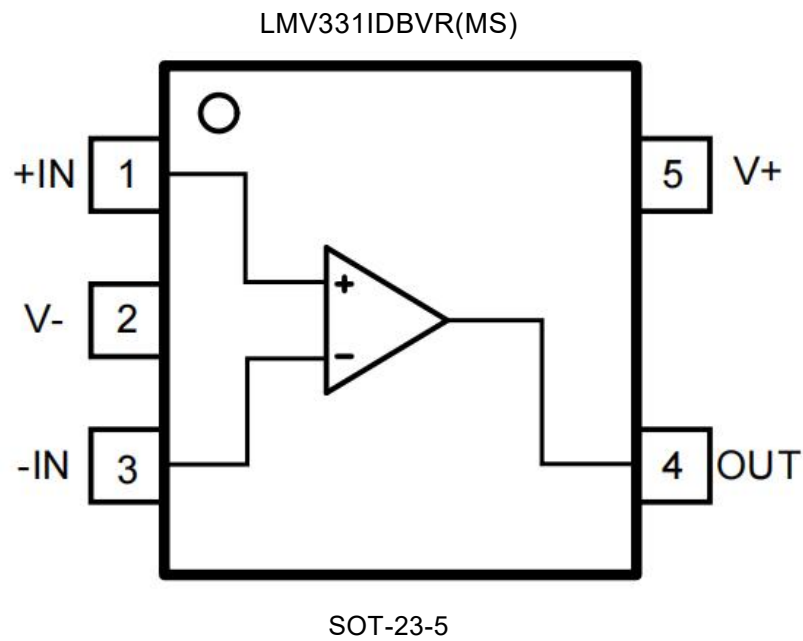

Pin Description

Pin Name	Pin Number	I/O	Description
	SOT23-5		
+IN	1	I	Noninverting input
V-	2	-	Negative(lowest) power supply
-IN	3	I	Inverting input
OUT	4	O	Output
V+	5	-	Positive (highest) power supply

Pin Configuration and Functions (Top View)

LMV393IDR(MS)

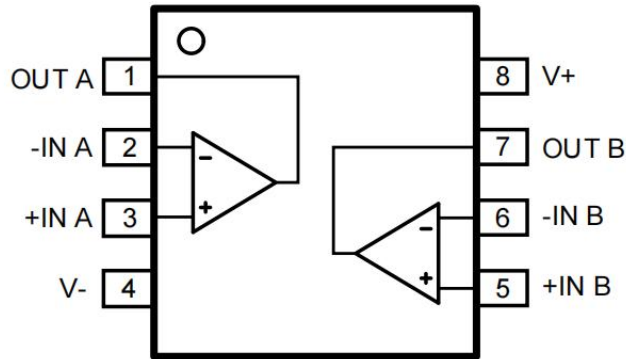

SOP-8

Pin Description

Pin Name	Pin Number	I/O	Description
	SOP-8		
OUTA	1	O	Output, channel A
-INA	2	I	Inverting input, channel A
+INA	3	I	Noninverting input, channel A
V-	4	-	Negative(lowest) power supply
+INB	5	I	Noninverting input, channel B
-INB	6	I	Inverting input, channel B
OUTB	7	O	Output, channel B
V+	8	-	Positive (highest) power supply

ELECTRICAL CHARACTERISTICS(V_S = 5.0V)

 At T_A = 25°C, V_{CM} = V_S/2, unless otherwise noted.

PARAMETER	CONDITIONS	MIN	TYP	MAX	UNIT
POWER SUPPLY					
Operating Voltage Range		2.1		5.5	V
Quiescent Current/per channel (Output High)			29		μA
Quiescent Current/per channel (Output Low)			50		μA
Power Supply Rejection Ratio	V _S = 2.1V to 5.5V, V _{CM} = V _S /2		70		dB
INPUT					
Input offset voltage		-4	±0.8	4	mV
Input Offset Voltage Drift			0.8		μV/°C
Common-Mode Voltage Range		(V ₋)-0.1		4.5	V
Common-mode Rejection Ratio	V _{CM} = -0.1V to 4.5V		70		dB
Input Bias Current			2		pA
Input Offset Current			1		pA
OUTPUT					
Saturation Voltage	I _O ≤ 4mA		100		mV
Output Pull-up Voltage Range				5.6	V
Output Current(sinking)	V _O ≤ 1.5V		50		mA
SWITCHING					
Propagation Delay H To L	R _{PU} = 5.1KΩ, Overdrive = 10mV		460		ns
	R _{PU} = 5.1KΩ, Overdrive = 100mV		400		
Propagation Delay L To H	R _{PU} = 5.1KΩ, Overdrive = 10mV		950		
	R _{PU} = 5.1KΩ, Overdrive = 100mV		850		
Fall Time	R _{PU} = 5.1KΩ, Overdrive = 100mV		36		ns

ELECTRICAL CHARACTERISTICS(V_S = 2.7V)

 At T_A = 25°C, V_{CM} = V_S/2, unless otherwise noted.

PARAMETER	CONDITIONS	MIN	TYP	MAX	UNIT
POWER SUPPLY					
Operating Voltage Range		2.1		5.5	V
Quiescent Current/per channel (Output High)			17		μA
Quiescent Current/per channel (Output Low)			30		μA
Power Supply Rejection Ratio	V _S = 2.1V to 5.5V, V _{CM} = V _S /2		70		dB
INPUT					
Input offset voltage		-4	±0.8	4	mV
Input Offset Voltage Drift			0.8		μV/°C
Common-Mode Voltage Range		(V ₋)-0.1		2.2	V
Common-mode Rejection Ratio	V _{CM} = -0.1V to 2.2V		70		dB
Input Bias Current			2		pA
Input Offset Current			1		pA
OUTPUT					
Saturation Voltage	I _O ≤ 4mA		82		mV
Output Pull-up Voltage Range				5.6	V
Output Current(sinking)	V _O ≤ 1.5V		20		mA
SWITCHING					
Propagation Delay H To L	R _{PU} = 5.1KΩ, Overdrive = 10mV		420		ns
	R _{PU} = 5.1KΩ, Overdrive = 100mV		380		
Propagation Delay L To H	R _{PU} = 5.1KΩ, Overdrive = 10mV		900		
	R _{PU} = 5.1KΩ, Overdrive = 100mV		880		
Fall Time	R _{PU} = 5.1KΩ, Overdrive = 100mV		36		ns

ELECTRICAL CHARACTERISTICS(V_S = 2.1V)

 At T_A = 25°C, V_{CM} = V_S/2, unless otherwise noted.

PARAMETER	CONDITIONS	MIN	TYP	MAX	UNIT
POWER SUPPLY					
Operating Voltage Range		2.1		5.5	V
Quiescent Current/per channel (Output High)			15		μA
Quiescent Current/per channel (Output Low)			26		μA
Power Supply Rejection Ratio	V _S = 2.1V to 5.5V, V _{CM} = V _S /2		70		dB
INPUT					
Input offset voltage		-4	±0.8	4	mV
Input Offset Voltage Drift			0.8		μV/°C
Common-Mode Voltage Range		(V ₋)-0.1		1.3	V
Common-mode Rejection Ratio	V _{CM} = -0.1V to 1.3V		70		dB
Input Bias Current			2		pA
Input Offset Current			1		pA
OUTPUT					
Saturation Voltage	I _O ≤ 4mA		96		mV
Output Pull-up Voltage Range				5.6	V
Output Current(sinking)	V _O ≤ 1.5V		7		mA
SWITCHING					
Propagation Delay H To L	R _{PU} = 5.1KΩ, Overdrive = 10mV		480		ns
	R _{PU} = 5.1KΩ, Overdrive = 100mV		430		
Propagation Delay L To H	R _{PU} = 5.1KΩ, Overdrive = 10mV		820		
	R _{PU} = 5.1KΩ, Overdrive = 100mV		800		
Fall Time	R _{PU} = 5.1KΩ, Overdrive = 100mV		38		ns

TYPICAL CHARACTERISTICS

At $T_A = 25^\circ\text{C}$, $V_S = +5\text{V}$, $V_{CM} = V_S/2$, unless otherwise noted.

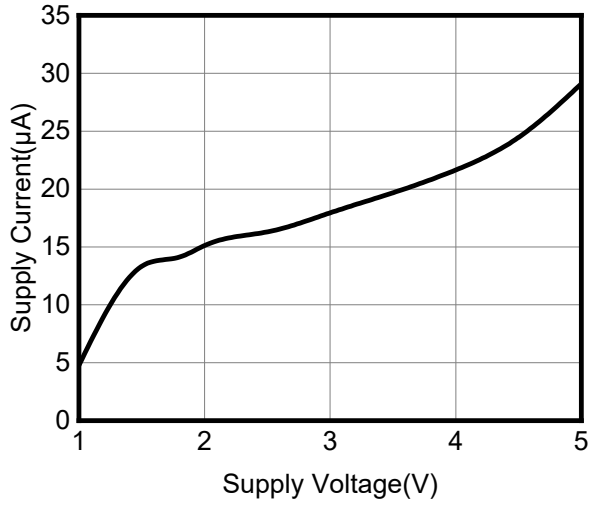

Figure 2. Supply Current vs Supply Voltage Output High

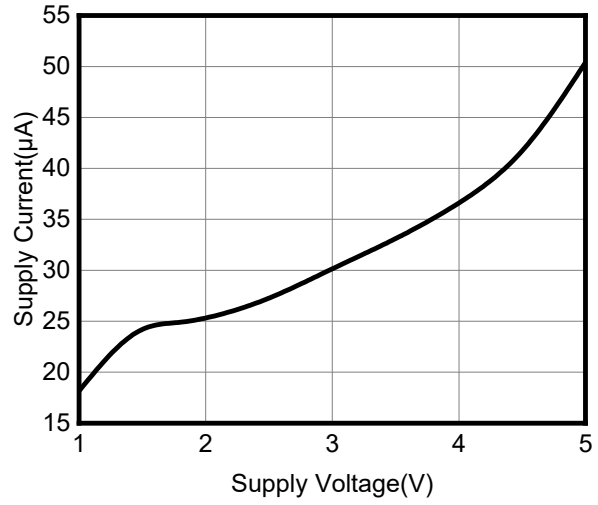

Figure 3. Supply Current vs Supply Voltage Output Low

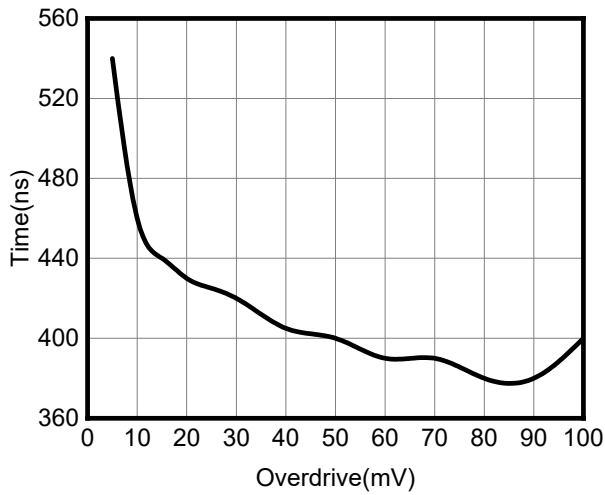

Figure 4. Response Time vs Input Overdrives Negative Transition ($V_{CC}=5\text{V}$)

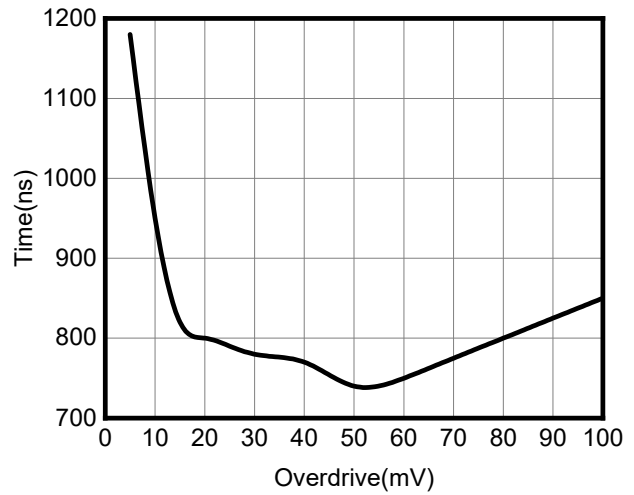

Figure 5. Response Time vs Input Overdrives Positive Transition ($V_{CC}=5\text{V}$)

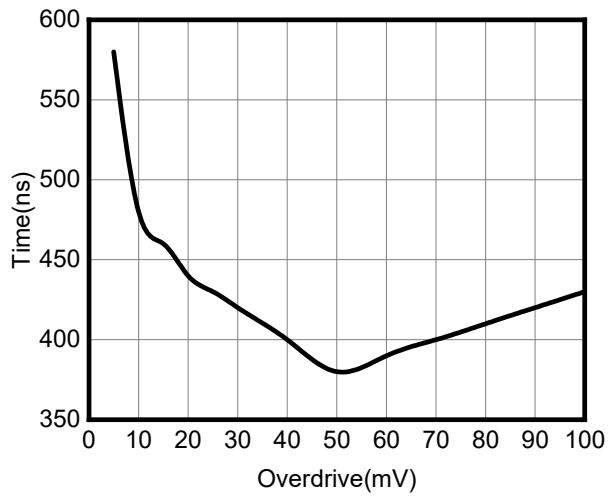

Figure 6. Response Time vs Input Overdrives Negative Transition($V_{CC}=2.1V$)

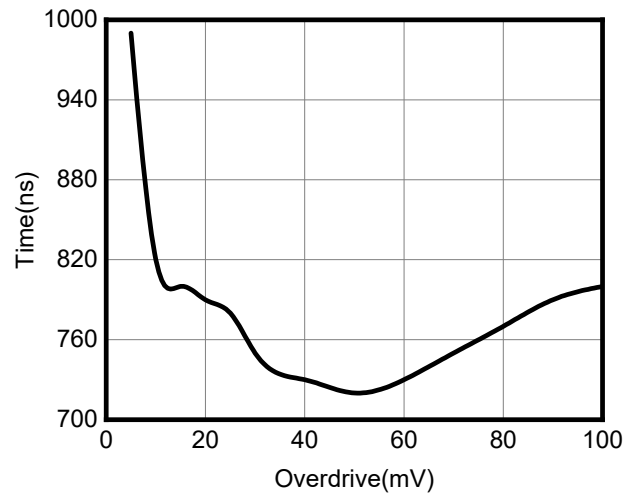

Figure 7. Response Time vs Input Overdrives Positive Transition($V_{CC}=2.1V$)

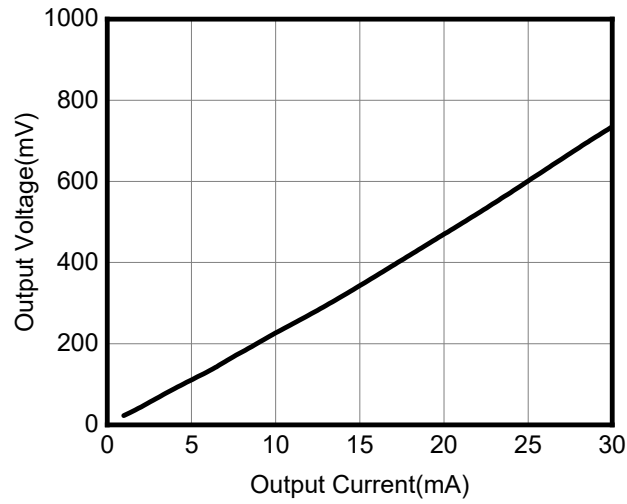

Figure 8. Output Voltage vs Output Current

DETAILED DESCRIPTION

Overview

The LMV331IDBVR(MS), LMV393IDR(MS) family of comparators can operate up to 5.5V on the supply pin.

This standard device has proven ubiquity and versatility across a wide range of applications.

This is due to its low power and high speed. The opendrain output allows the user to configure the output's logic low voltage (V_{OL}) and can be utilized to enable the comparator to be used in AND functionality.

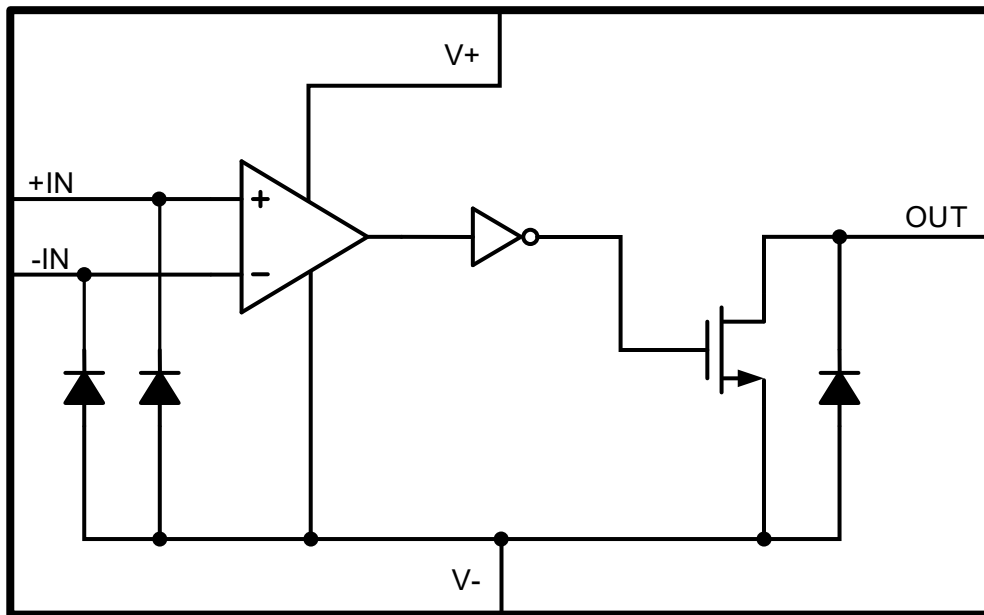

Figure 9. Functional Block Diagram

APPLICATION and IMPLEMENTATION

Application Information

LMV331IDBVR(MS), LMV393IDR(MS) will typically be used to compare a single signal to a reference or two signals against each other. Many users take advantage of the open drain output (logic high with pull-up) to drive the comparison logic output to a logic voltage level to an MCU or logic device.

Typical Application

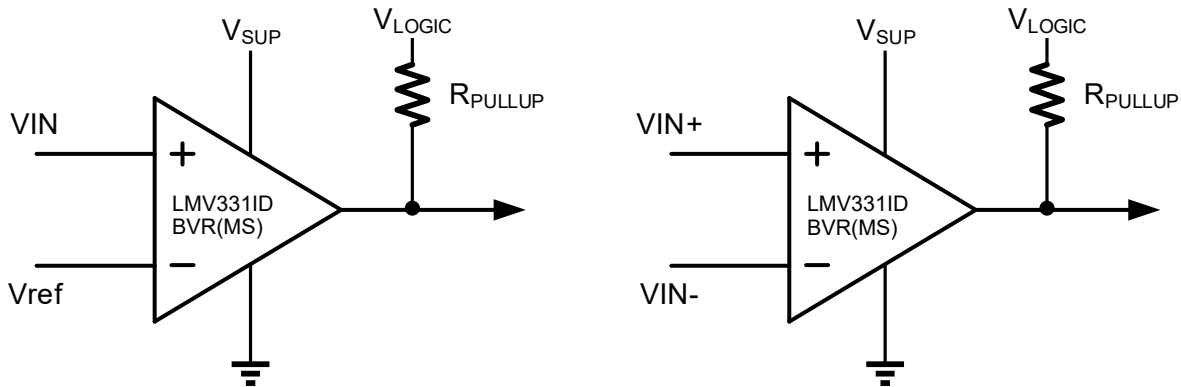

Figure 10. Typical Application Schematic

Power Supply Recommendations

For fast response and comparison applications with noisy or AC inputs, it is recommended to use a bypass capacitor on the supply pin to reject any variation on the supply voltage. This variation causes temporary fluctuations in the comparator's input common mode range and create an inaccurate comparison.

Layout

Layout Guidelines

For accurate comparator applications without hysteresis it is important maintain a stable power supply with minimized noise and glitches, which can affect the high-level input common mode voltage range. In order to achieve this, it is best to add a bypass capacitor between the supply voltage and ground. This should be implemented on the positive power supply and negative supply (if available). If a negative supply is not being used, do not put a capacitor between the IC's GND pin and system ground.

Layout Example

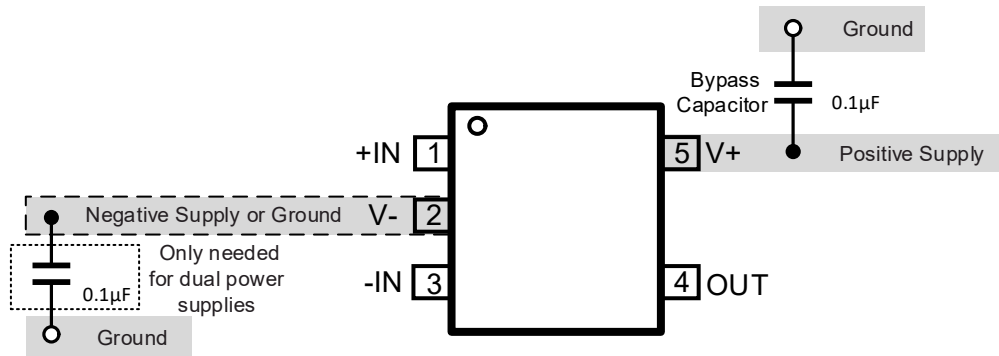
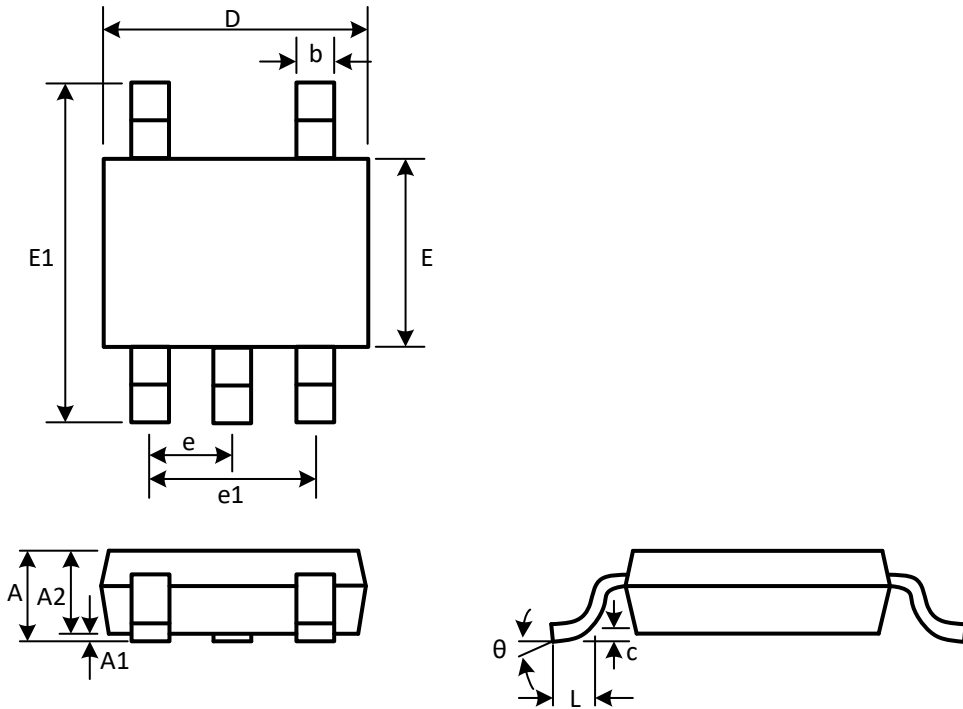

Figure 11. LMV331IDBVR(MS) Layout Example

PACKAGE DESCRIPTION

SOT-23-5



(Unit: mm)

Symbol	Min	Max
A	1.050	1.250
A1	0.000	0.100
A2	1.050	1.150
b	0.300	0.500
c	0.100	0.200
D	2.820	3.020
e	0.950(BSC)	
e1	1.800	2.000
E	1.500	1.700
E1	2.650	2.950
L	0.300	0.600
θ	0°	8°

Pin Configuration and Functions (Top View)

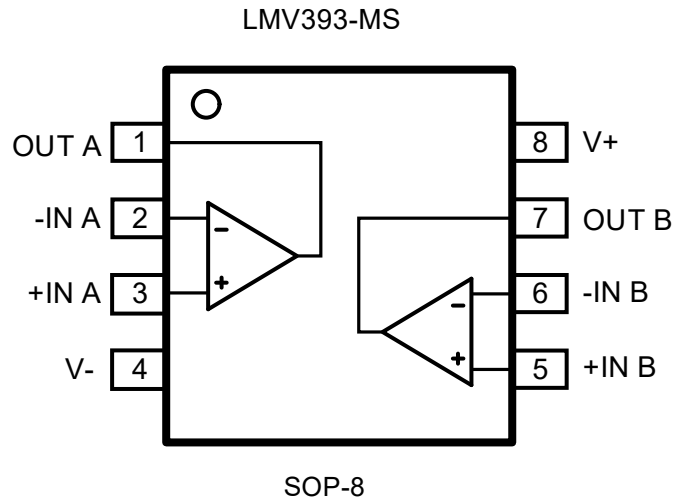

Pin Description

Pin Name	Pin Number	I/O	Description
	SOP-8		
OUTA	1	O	Output, channel A
-INA	2	I	Inverting input, channel A
+INA	3	I	Noninverting input, channel A
V-	4	-	Negative(lowest) power supply
+INB	5	I	Noninverting input, channel B
-INB	6	I	Inverting input, channel B
OUTB	7	O	Output, channel B
V+	8	-	Positive (highest) power supply

Attention

- Any and all MSKSEMI Semiconductor products described or contained herein do not have specifications that can handle applications that require extremely high levels of reliability, such as life-support systems, aircraft's control systems, or other applications whose failure can be reasonably expected to result in serious physical and/or material damage. Consult with your MSKSEMI Semiconductor representative nearest you before using any MSKSEMI Semiconductor products described or contained herein in such applications.
- MSKSEMI Semiconductor assumes no responsibility for equipment failures that result from using products at values that exceed, even momentarily, rated values (such as maximum ratings, operating condition ranges, or other parameters) listed in products specifications of any and all MSKSEMI Semiconductor products described or contained herein.
- Specifications of any and all MSKSEMI Semiconductor products described or contained herein stipulate the performance, characteristics, and functions of the described products in the independent state, and are not guarantees of the performance, characteristics, and functions of the described products as mounted in the customer's products or equipment. To verify symptoms and states that cannot be evaluated in an independent device, the customer should always evaluate and test devices mounted in the customer's products or equipment.
- MSKSEMI Semiconductor strives to supply high-quality high-reliability products. However, any and all semiconductor products fail with some probability. It is possible that these probabilistic failures could give rise to accidents or events that could endanger human lives, that could give rise to smoke or fire, or that could cause damage to other property. When designing equipment, adopt safety measures so that these kinds of accidents or events cannot occur. Such measures include but are not limited to protective circuits and error prevention circuits for safe design, redundant design, and structural design.
- In the event that any or all MSKSEMI Semiconductor products (including technical data, services) described or contained herein are controlled under any of applicable local export control laws and regulations, such products must not be exported without obtaining the export license from the authorities concerned in accordance with the above law.
- No part of this publication may be reproduced or transmitted in any form or by any means, electronic or mechanical, including photocopying and recording, or any information storage or retrieval system, or otherwise, without the prior written permission of MSKSEMI Semiconductor.
- Information (including circuit diagrams and circuit parameters) herein is for example only ; it is not guaranteed for volume production. MSKSEMI Semiconductor believes information herein is accurate and reliable, but no guarantees are made or implied regarding its use or any infringements of intellectual property rights or other rights of third parties.
- Any and all information described or contained herein are subject to change without notice due to product/technology improvement, etc. When designing equipment, refer to the "Delivery Specification" for the MSKSEMI Semiconductor product that you intend to use.

X-ON Electronics

Largest Supplier of Electrical and Electronic Components

Click to view similar products for [Analog Comparators](#) category:

Click to view products by [MSKSEMI](#) manufacturer:

Other Similar products are found below :

[SC2903VDR2G](#) [LM2901SNG](#) [LM339SNG](#) [55122](#) [5962-8757203IA](#) [NTE911](#) [LM339EDR2G](#) [NTE922](#) [UPC177GR-9LG-E2-A](#)
[HT393VRMZ](#) [LM2903YD](#) [NCV2200SN1T1G](#) [LM2903A-SR](#) [HT339ARQZ](#) [LM2901XP](#) [LM2903DR-JSM](#) [LM239AM/TR](#)
[LM393LVQDGKRQ1](#) [LM393LVQPWRQ1](#) [LM2903BWDSGRQ1](#) [TLV3801DSGT](#) [AD790JRZ-REEL](#) [LM339A-TR](#) [LT6700HVHS6-1#TRPBF](#) [GS2903-SR](#) [LMV7219M5/TR](#) [LMV7239M5/TR](#) [LM293ADR-HXY](#) [LM339N-HXY](#) [LM393P-HXY](#) [IL339DT](#) [LM2901XQ](#)
[RS331XF-Q1](#) [MIC842NYMT-TR](#) [LM393FVM-TR](#) [LM393P](#) [TLV3602DGKR](#) [TLV3602QDGKRQ1](#) [TLV7032QDGKRQ1](#)
[TLV3601QDBVRQ1](#) [LM2901BQPWRQ1](#) [TLV3603DCKR](#) [TLV3603DCKT](#) [AiP74HC85TA16.TB](#) [LMV331IDBVR\(MS\)](#) [LMV331TP-MS](#)
[LMV331W5-7\(MS\)](#) [MCP6561UT-E\(MS\)](#) [LMV331-MS](#) [TS331ILT\(MS\)](#)