

MSKSEMI

SEMICONDUCTOR



ESD



TVS



TSS



MOV



GDT



PLED

Product data sheet

■ 特性

- 低功耗，完全兼容产品
MAX706P/R/S/T、MAX708R/S/T、MAX705/6/7/8、MAX813L：
供应电流 (100μA)
- 6 种高精度的电压监测可选
- 手动复位输入
- 内置 1.25V 电压监控器
- 看门狗功能 (706P/R/S/T/J、705/6/813L)
- 200ms 复位延迟输出
- 3 种复位信号可选
- 8 引脚 DIP、SOP、MSOP 封装

■ 应用

- 电脑和控制器
- 嵌入式系统
- 电池供电系统
- 智能仪器
- 无线通信系统
- PDA 和便携式设备

■ 概述

706P/R/S/T/J、708R/S/T/J、705/6/7/8、和 813L 芯片主要用于监控电源电压和电池电压。当电源电压低于 2.63V (706P/R, 708R)、2.93V (706S, 708S)、3.08V (706T, 708T)、4.00V (706J, 708J)、4.40V (706/708)、或 4.65V (705/707, 813L) 时，将产生复位信号。

706P/R/S/T/J、705/706/813L 芯片具有一个 1.6 秒延时复位的看门狗电路。将 WDI 引脚悬空可以禁用看门狗计时器。

708R/S/T/J、707/708 芯片具有高电平和低电平两种复位电平输出，但没有看门狗功能。706P 芯片与 706R 芯片的功能基本一致，但复位输出高电平。813L 与 705 芯片的功能也基本一致，但复位输出为高电平。

内置 1.25V 比较器，可用于监测电池的低电压。所有的芯片都具有手动复位功能。

封装形式有 8 引脚 DIP、SOP 和紧凑型 MSOP。

■ 结构框图



图 1 706P/R/S/T/J, 708R/S/T/J, 705/6/7/8, 813L 的结构示意图

■ 管脚分布



图 2 706P、813L 的管脚分布示意图

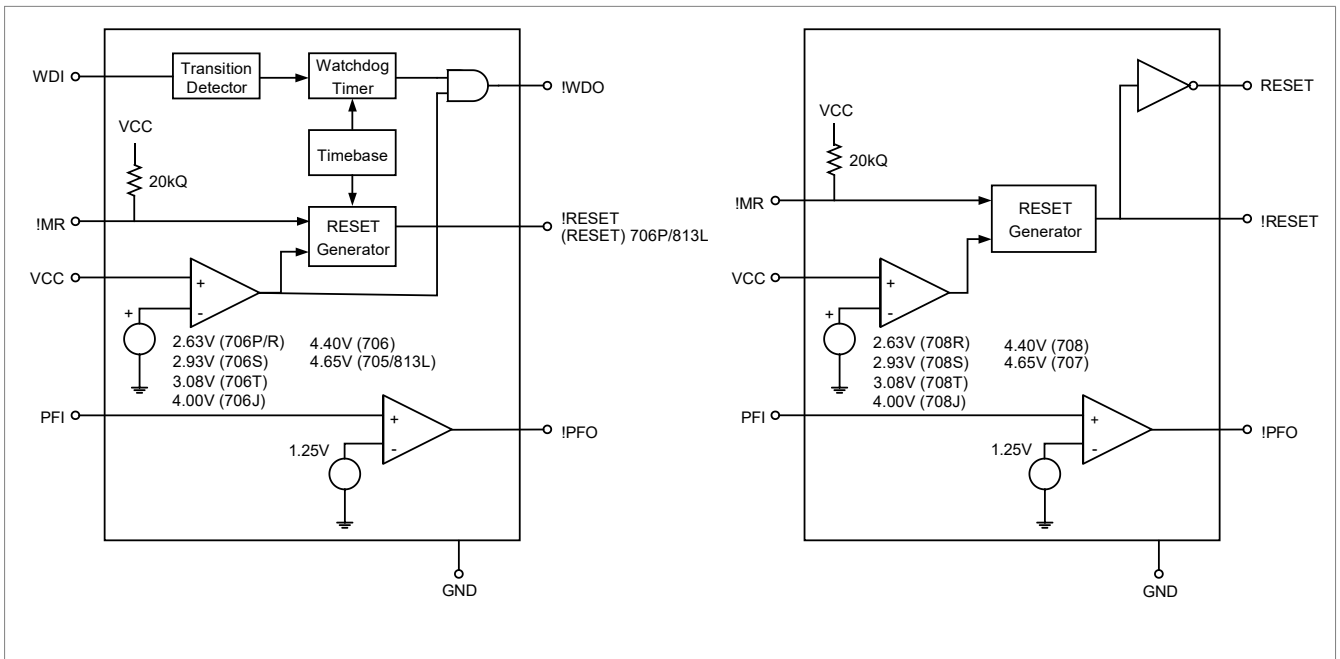

图 3 706R/S/T/J、705/706 的管脚分布示意图

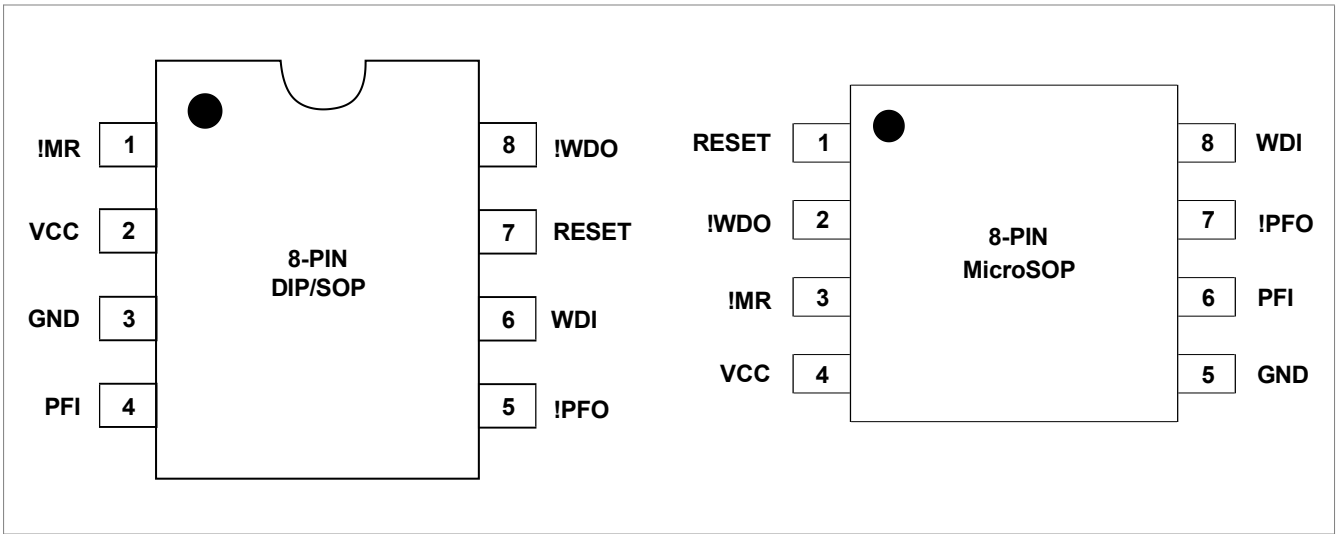

图 4 708R/S/T/J、707/708 的管脚分布示意图

■ 引脚功能

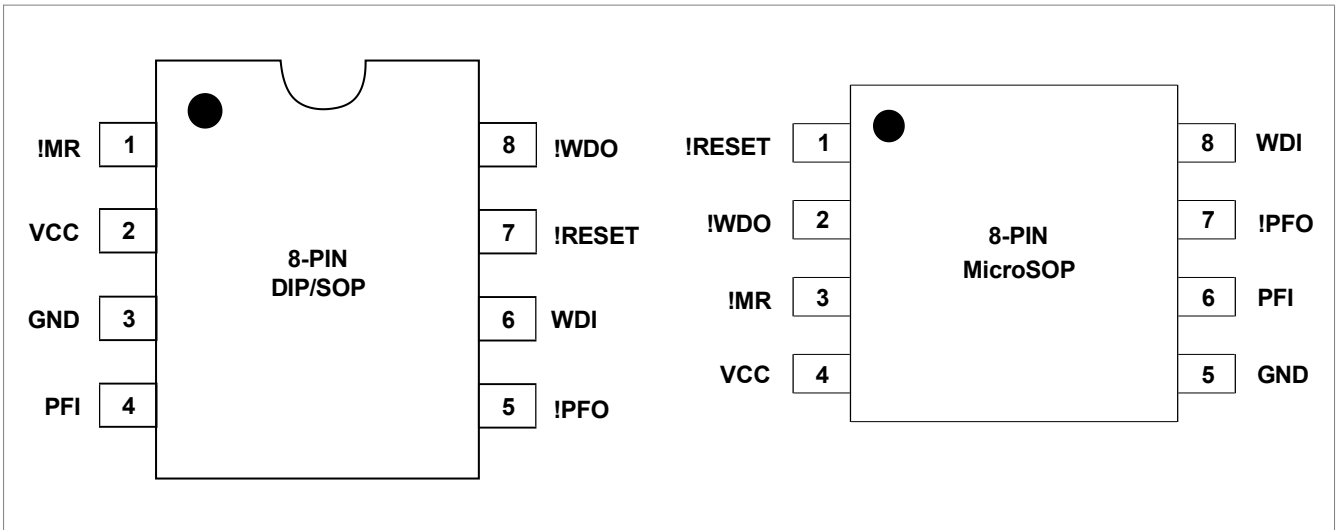
表 1 706P/R/S/T/J, 708R/S/T/J, 705/6/7/8, 813L 的引脚功能描述

引脚	符号	描述
1	VCC	电源
2	GND	地
3	!MR	手动复位输入
4	PFI	1.25V 内置比较器反向输入端
5	!PFO	1.25V 内置比较器输出端
6	WDI	看门狗输入端， 将该引脚悬空可屏蔽看门狗功能
7	!WDO	看门狗输出端
8	RESET	高电平复位信号输出， RESET 与!RESET 反相
9	!RESET	低电平复位信号输出
10	NC	无

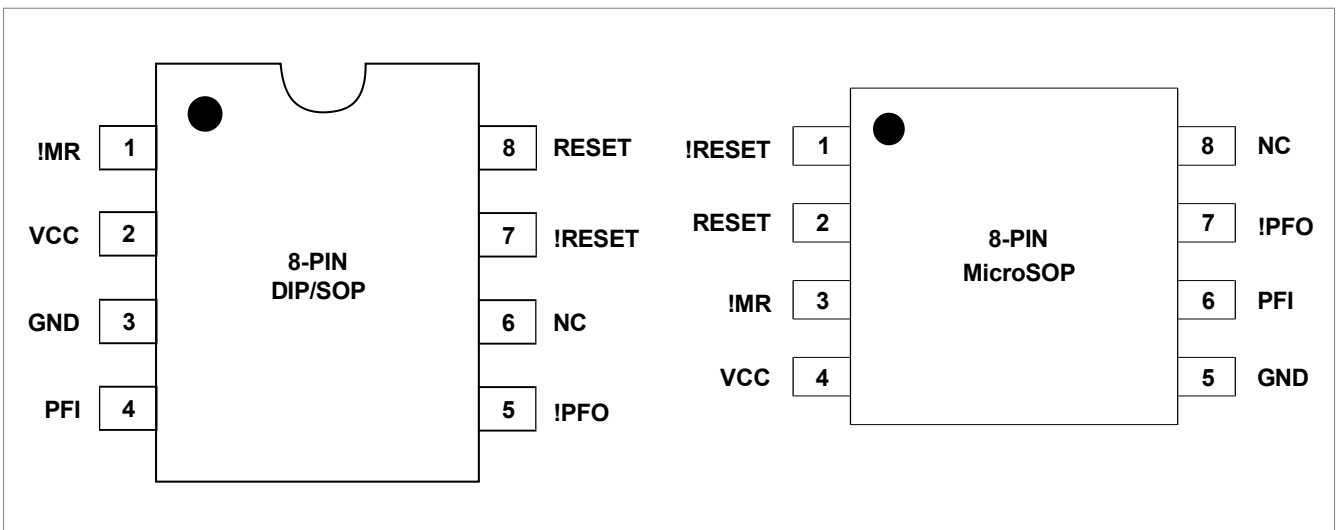
■ 电气参数

除非特别说明，典型值为：TA = 25°C。

706P/R、708R 型器件的电源电压为 3.0V 至 5.5V，706/8S 型器件的电源电压为 3.3V 至 5.5V，706/8T 型器件的电源电压为 3.5V 至 5.5V，706/8J 型器件的电源电压为 4.4V 至 5.5V，706/708 型器件的电源电压为 4.8V 至 5.5V，705/707/813L 型器件的电源电压为 5.0V 至 5.5V。

表 2 706P/R/S/T/J, 708R/S/T/J, 705/6/7/8, 813L 的电气特性参数

符号	描述	测试条件	参数			单位
			最小值	典型值	最大值	
VCC	工作电压范围	706xC, 708xC, 813L	1.1		5.5	V
		706xE, 708xE, 813LE 705/6/7/8xC, 705/6/7/8xE,	1.2	-	5.5	
ICC	电源电流 VCC < 3.6V	706xC, 706xE, MR = VCC, WDI 悬空	-	75	140	μ A
		708xC, 708xE, MR = VCC, WDI 悬空	-	50	140	
	电源电流 VCC < 5.5V	706xC, 706xE, MR = VCC, WDI 悬空	-	75	140	
		708xC, 708xE, MR = VCC, WDI 悬空	-	50	140	
	-	705C, 706C, 813C	-	75	140	
		705E, 706E, 813LE	-	75	140	
		707C, 708C	-	50	140	
		707E, 708E	-	50	140	
VRT	复位阈值	P、R 型器件	2.55	2.63	2.70	V
		S 型器件	2.85	2.93	3.00	
		T 型器件	3.00	3.08	3.15	
		J 型器件	3.89	4.00	4.10	
		706, 708	4.25	4.40	4.50	
		705, 707, 813L	4.50	4.65	4.75	
	复位阈值滞后	-	-	40	-	mV
tRS	RESET 脉冲宽度	P、R 型器件, VCC = 3V	140	200	280	ms
		S、T 型器件, VCC = 3.3V	-	-	-	
		J 型器件, VCC = 4.4V	-	-	-	
		VCC = 5V	-	200	-	
tMR	!MR 脉冲宽度	4.5V < VCC < 5.5V	150	-	-	ns
		J 型器件, 3.6V < VCC < 4.5V	500	-	-	
		P/R/S/T 型器件, VRST (MAX) < VCC < 3.6V				

■ 电气参数

除非特别说明，典型值为：TA=25°C。

706P/R、708R 型器件的电源电压为 3.0V 至 5.5V，706/8S 型器件的电源电压为 3.3V 至 5.5V，706/8T 型器件的电源电压为 3.5V 至 5.5V，706/8J 型器件的电源电压为 4.4V 至 5.5V，706/708 型器件的电源电压为 4.8V 至 5.5V，705/707/813L 型器件的电源电压为 5.0V 至 5.5V。

表 3 706P/R/S/T/J, 708R/S/T/J, 705/6/7/8, 813L 的电气特性参数(续)

符号	描述	测试条件	参数			单位
			最小值	典型值	最大值	
tMD	!MR 至 RESET 输出延迟	J 型器件 3.6V < VCC < 4.5V	-	-	750	ns
		P/R/S/T 型器件, VRST(MAX) < VCC < 3.6V				
		4.5V < VCC < 5.5V	-	-	250	
VIH	!MR 输入阈值电压	VRST (MAX) < VCC < 4.5V	0.7VCC	-	-	V
VIL		VRST (MAX) < VCC < 4.5V	-	-	0.6	
VIH		4.5V < VCC < 5.5V	2.0	-	-	
VIL		4.5V < VCC < 5.5V	-	-	0.8	
RP	!MR 上拉电阻	-	10	20	40	kΩ
VOH	!RESET 输出电压	ISOURCE = 800μA, 4.5V < VCC < 5.5V	VCC-1.5V	-	-	V
VOL		ISINK = 3.2mA, 4.5V < VCC < 5.5V	-	-	0.4	
VOH		ISOURCE = 500μA, VRST (MAX) < VCC < 4.5V	0.8VCC	-	-	
VOL		ISINK = 1.2mA, VRST (MAX) < VCC < 4.5V	-	-	0.3	
VOL		706*C, 708*C, SINK = 50μA, VCC = 1.1V	-	-	0.3	
		706*E, 708*E, 705/6/7/8 ISINK = 100μA, VCC = 1.2V	-	-	0.3	
VOH	RESET 输出电压, 706P 型器件	ISOURCE = 800μA, 4.5V < VCC < 5.5V	VCC-1.5V	-	-	V
VOL		ISINK = 3.2mA, 4.5V < VCC < 5.5V	-	-	0.4	
VOH		ISOURCE = 500μA, VRST (MAX) < VCC < 3.6V	0.8VCC	-	-	
VOL		ISINK = 1.2mA, VRST (MAX) < VCC < 3.6V	-	-	0.3	

■ 电气参数 (续)

除非特别说明，典型值为：TA=25°C。

706P/R、708R 型器件的电源电压为 3.0V 至 5.5V，706/8S 型器件的电源电压为 3.3V 至 5.5V，706/8T 型器件的电源电压为 3.5V 至 5.5V，706/8J 型器件的电源电压为 4.4V 至 5.5V，706/708 型器件的电源电压为 4.8V 至 5.5V，705/707/813L 型器件的电源电压为 5.0V 至 5.5V。

表 4 706P/R/S/T/J, 708R/S/T/J, 705/6/7/8, 813L 的电气特性参数(续)

符号	描述	测试条件	参数			单位
			最小值	典型值	最大值	
VOH	RESET 输出电压, 708R/S/T/J 型器件	ISOURCE = 800μA, 4.5V < VCC < 5.5V	VCC- 1.5V	-		V
VOL		ISINK = 3.2mA, 4.5V < VCC < 5.5V	-	-	0.4	
VOH		ISOURCE = 500μA, VRST (MAX) < VCC < 4.5V	0.8VCC	-		
VOL		ISINK = 1.2mA, VRST (MAX) < VCC < 4.5V	-	-	0.3	
VOH	RESET 输出电压, 705/6/7/8, 813L 型器 件	707/708/813L, ISOURCE = 800μA	VCC- 1.5V			V
VOL		707/708, ISINK = 1.2mA			0.4	
VOH		813L, VCC = 1.2V, ISOURCE = 4μA,	0.9			
VOL		813L, ISINK = 3.2mA			0.4	
tWD	看门狗延迟时间	706P/R 型器件, VCC = 3V 706S/T 型器件, VCC = 3.3V 706J 型器件, VCC = 4.4V 705/706/813L	1.0	1.6	2.25	s
tWP	WDI 脉冲宽度	VIL = 0.4V, VIH = 0.8VCC, VRST (MAX) < VCC < 4.5V VIL = 0.4V, VIH = 0.8VCC, 4.5V < VCC < 5.5V	100 50	- -	- -	ns
VIH	WDI 输入阈值电压	VCC = 5V	3.5	-	-	V
VIL		-	-	-	0.8	
VIH		VRST (MAX) < VCC < 4.5V	0.7VCC	-	-	
VIL		-	-	-	0.6	
	WDI 输入电流	WDI = VCC 706, 705/6, 813L 型器件 WDI = 0V 706, 705/6, 813L 型器件	- -150	50 -50	150 -	μA

■ 电气参数 (续)

除非特别说明，典型值为：TA = 25°C。

706P/R、708R 型器件的电源电压为 3.0V 至 5.5V，706/8S 型器件的电源电压为 3.3V 至 5.5V，706/8T 型器件的电源电压为 3.5V 至 5.5V，706/8J 型器件的电源电压为 4.4V 至 5.5V，706/708 型器件的电源电压为 4.8V 至 5.5V，705/707/813L 型器件的电源电压为 5.0V 至 5.5V。

表 5 706P/R/S/T/J, 708R/S/T/J, 705/6/7/8, 813L 的电气特性参数(续)

符号	描述	测试条件	参数			单位
			最小值	典型值	最大值	
VOH	!WDO 输出电压	ISOURCE = 800μA, 4.5V < VCC < 5.5V	VCC- 1.5V	-	-	V
VOL		ISINK = 1.2mA, 4.5V < VCC < 5.5V	-	-	0.4	
VOH		ISOURCE = 500μA, VRST (MAX) < VCC < 4.5V	0.8VCC	-	-	
VOL		ISINK = 500μA, VRST (MAX) < VCC < 4.5V	-	-	0.3	
	PFI 输入阈值电压	PFI falling. P/R 型器件 VCC = 3V S/T 型器件 VCC = 3.3V J 型器件 VCC = 4.4V	1.2	1.25	1.3	V
	PFI 输入电流	-	-25	0.01	25	nA
VOH	!PFO 输出电压	ISOURCE = 800μA, 4.5V < VCC < 5.5V	VCC- 1.5V	-	-	V
VOL		ISINK = 3.2mA, 4.5V < VCC < 5.5V	-	-	0.4	
VOH		ISOURCE = 500μA, VRS (MAX) < VCC < 4.5V	0.8VCC	-	-	
VOL		ISINK = 1.2mA, VRS (MAX) < VCC < 4.5V	-	-	0.3	

■ 典型性能参数



图 5 706P/R/S/T/J, 708R/S/T/J, 705/6/7/8, 813L 的复位信号时序图



图 6 看门狗时序图

■ 典型性能参数 (续)

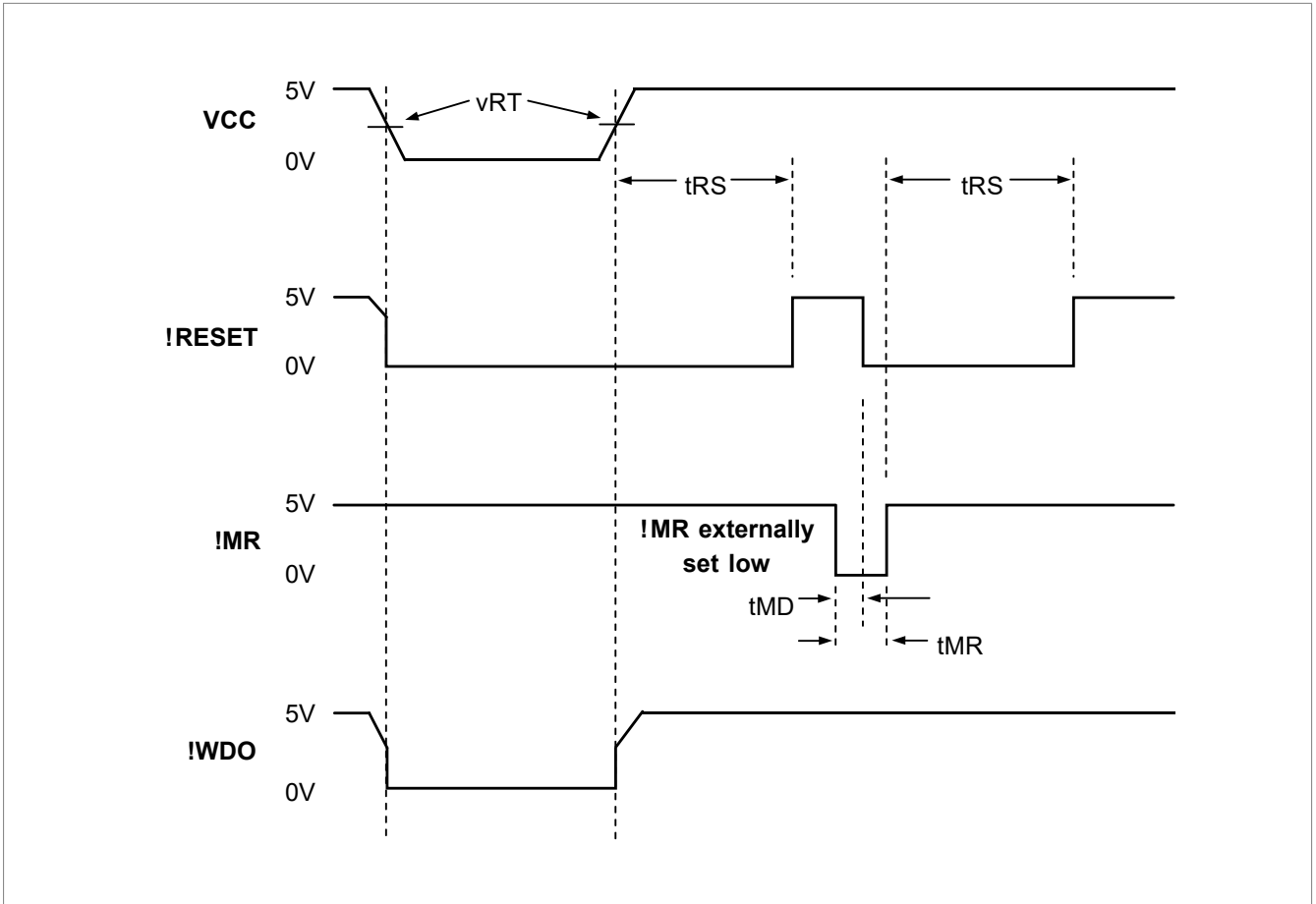

图 7 确保!RESET 正常工作电路

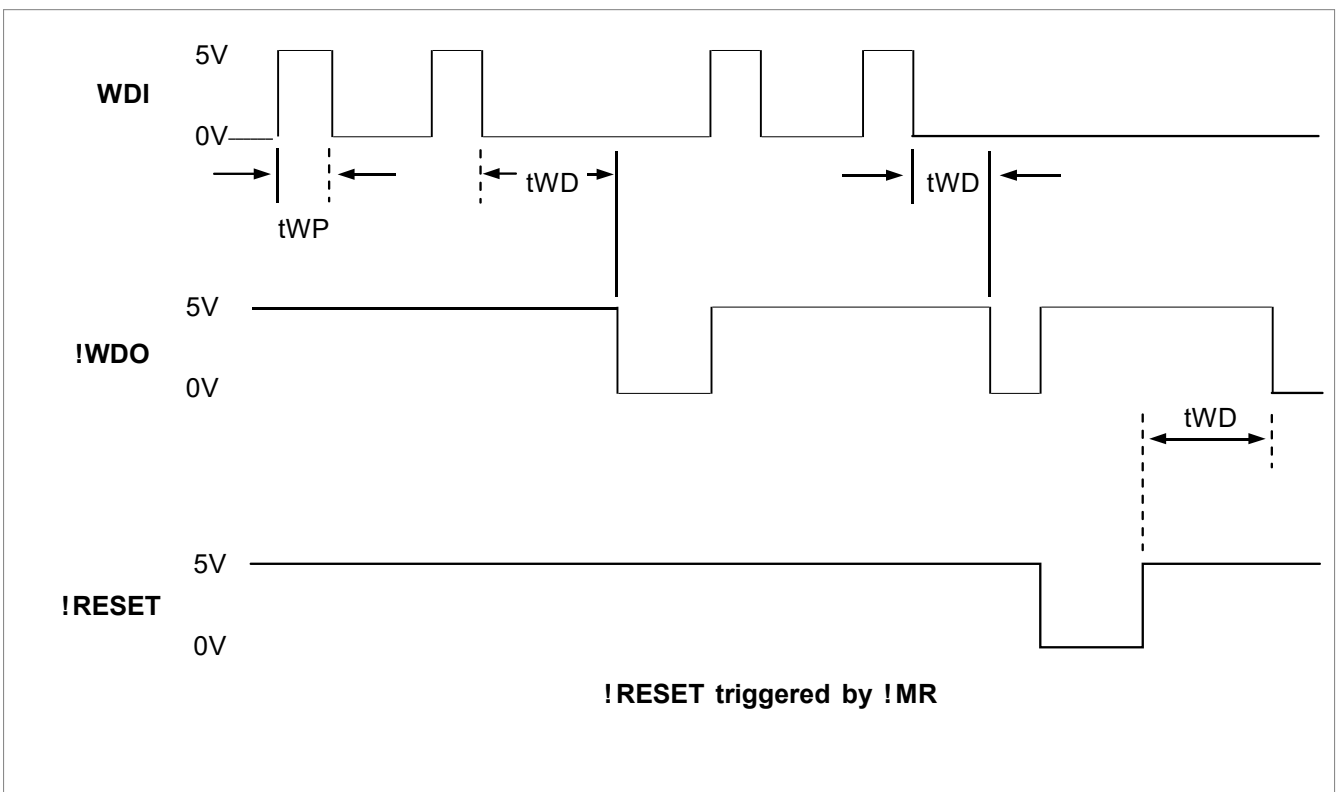

图 8 双向复位端口连接示意图

■ 典型性能参数 (续)

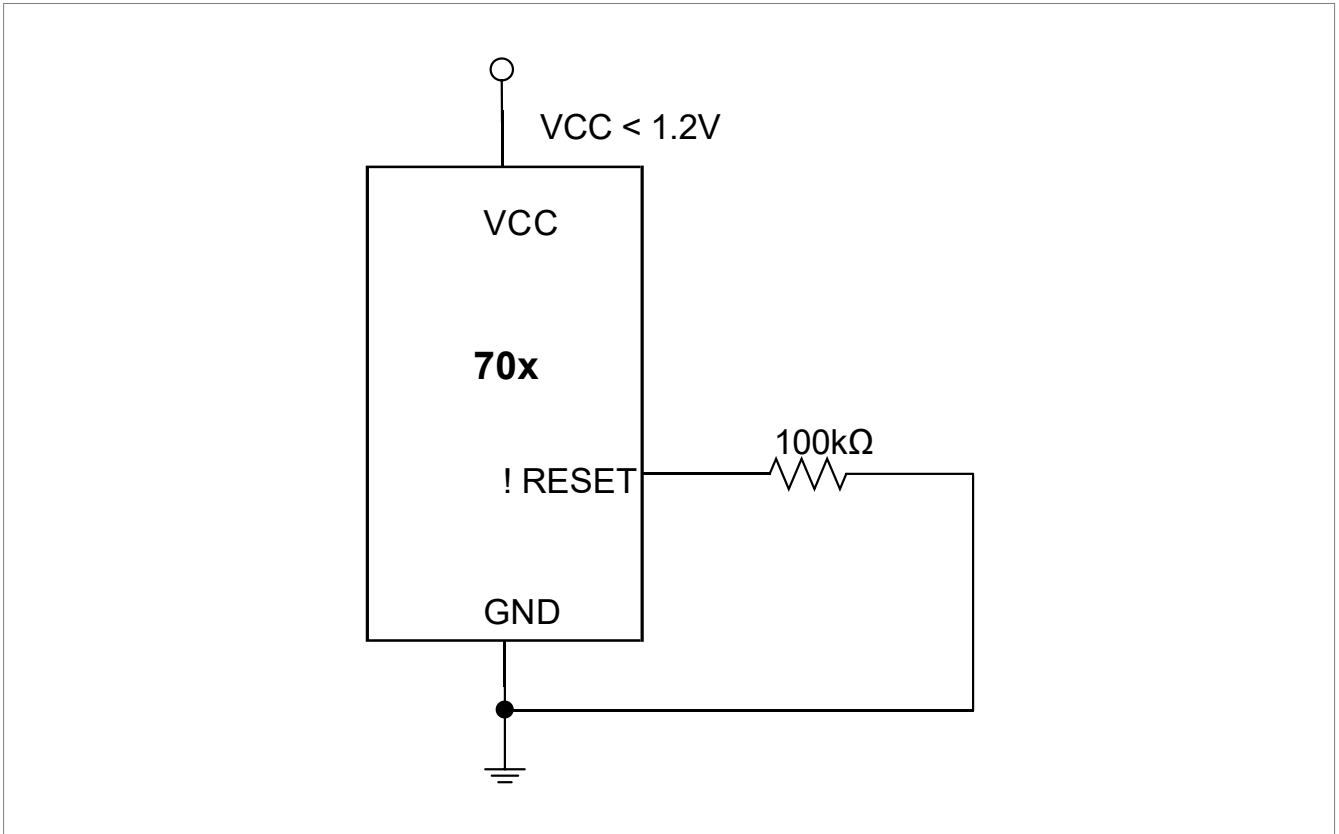

图 9 监控 VCC 以外的电压示意图

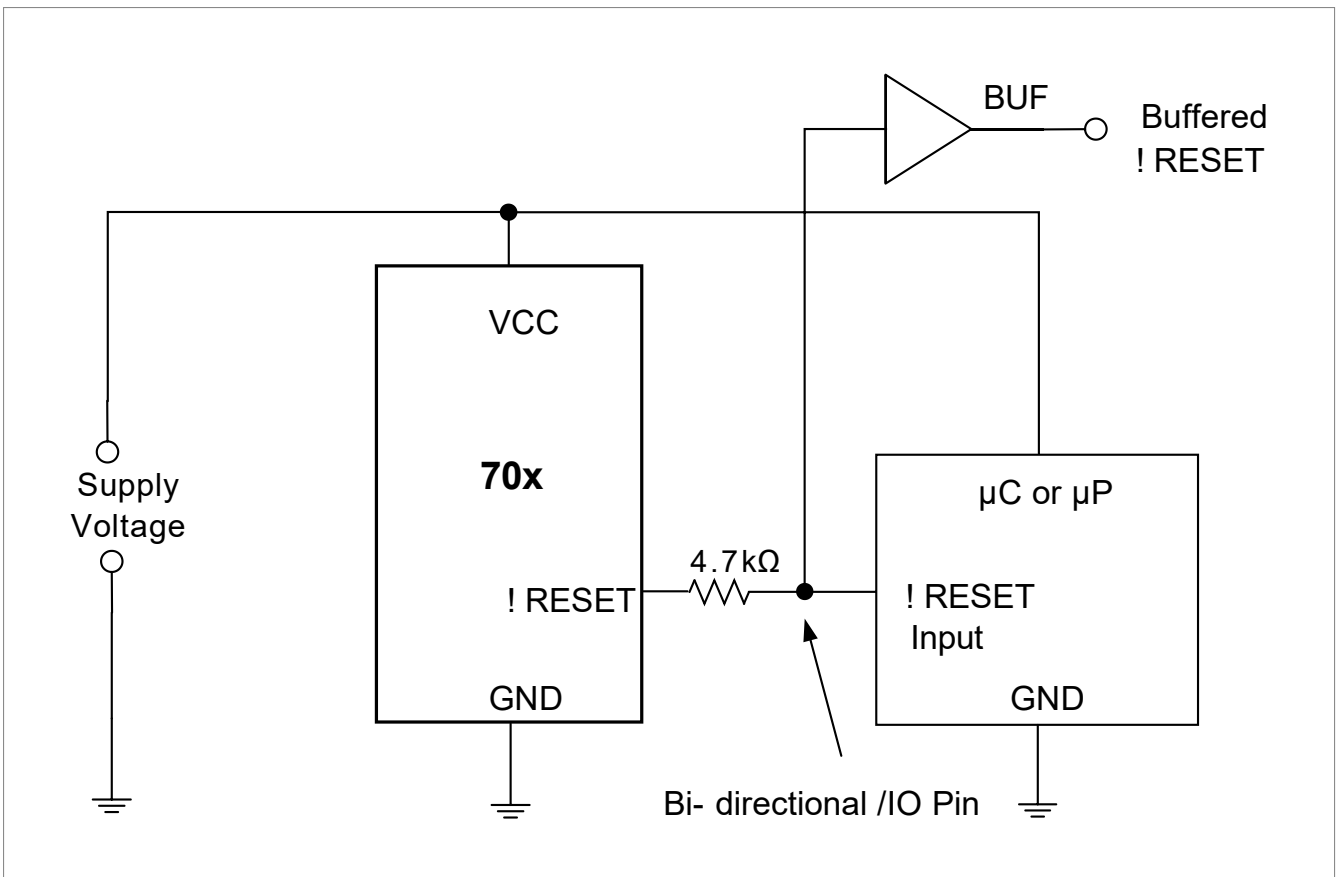

图 10 负电压监控电路

■ 功能概述

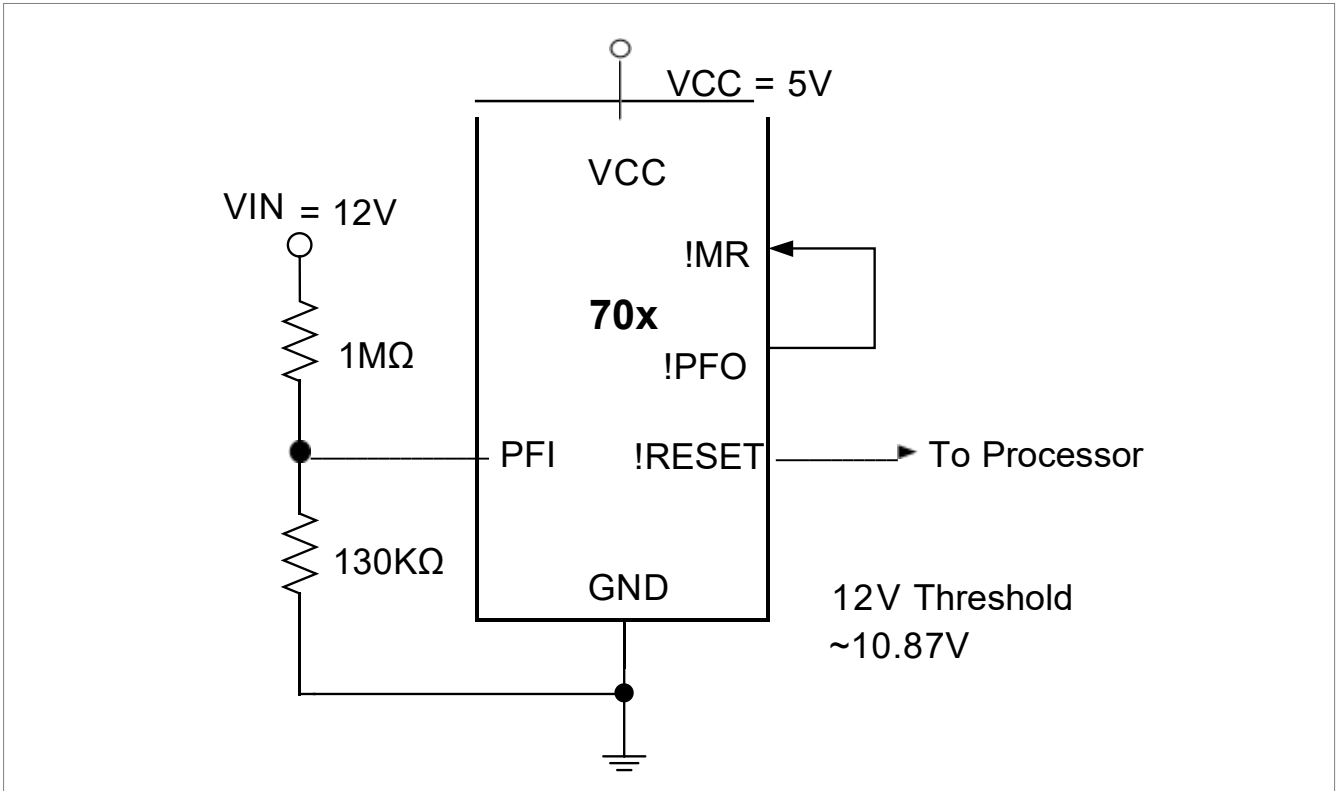
表 6 706P/R/S/T/J, 708R/S/T/J, 705/6/7/8, 813L 的功能概述

型号	功能 看门狗	复位输出电平		电源故障监测	掉电监测	手动复位输入	上电/掉电复位	复位阈值电压
		高	低					
706P	■	■		■	■	■	■	2.63V
706R	■		■	■	■	■	■	2.63V
706S	■		■	■	■	■	■	2.93V
706T	■		■	■	■	■	■	3.08V
706J	■		■	■	■	■	■	4.00V
708R		■	■	■	■	■	■	2.63V
708S		■	■	■	■	■	■	2.93V
708T		■	■	■	■	■	■	3.08V
708J		■	■	■	■	■	■	4.00V
705	■		■	■	■	■	■	4.65V 或 4.00V
706	■		■	■	■	■	■	4.40V
707		■	■	■	■	■	■	4.65V
708		■	■	■	■	■	■	4.40V
813L	■	■		■	■	■	■	4.65V

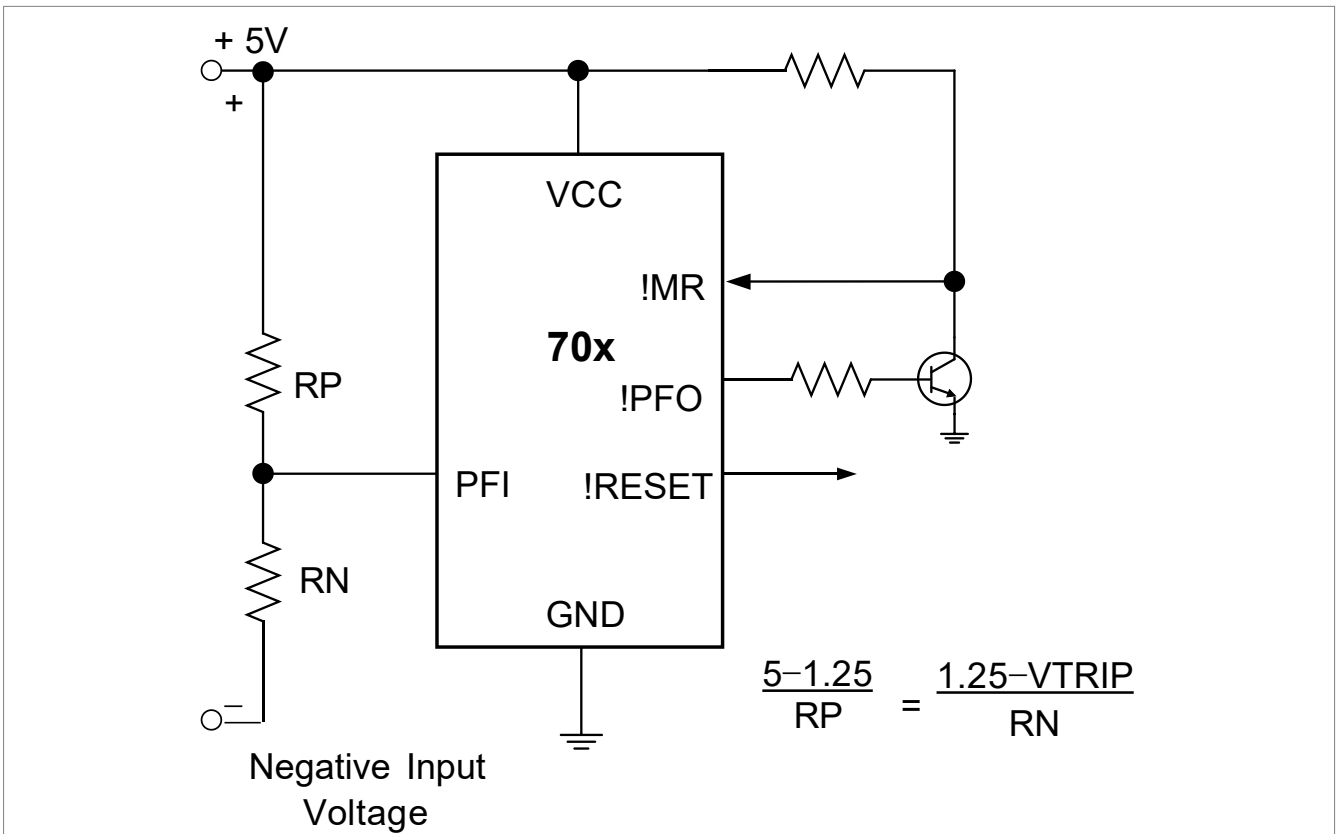
■ 封装信息-DIP



图 11 8-DIP 的封装示意图

表 7 8-DIP 的封装参数

符号	尺寸单位(毫米)		尺寸单位(英寸)	
	最小值	最大值	最小值	最大值
A	3.710	4.310	0.146	0.170
A1	0.510		0.020	
A2	3.200	3.600	0.126	0.142
B	0.380	0.570	0.015	0.022
B1	1.524(BSC)		0.060(BSC)	
C	0.204	0.360	0.008	0.014
D	9.000	9.400	0.354	0.370
E	6.200	6.600	0.244	0.260
E1	7.320	7.920	0.288	0.312
e	2.540(BSC)		0.100(BSC)	
L	3.000	3.600	0.118	0.142
E2	8.400	9.000	0.331	0.354

■ 封装信息-SOP

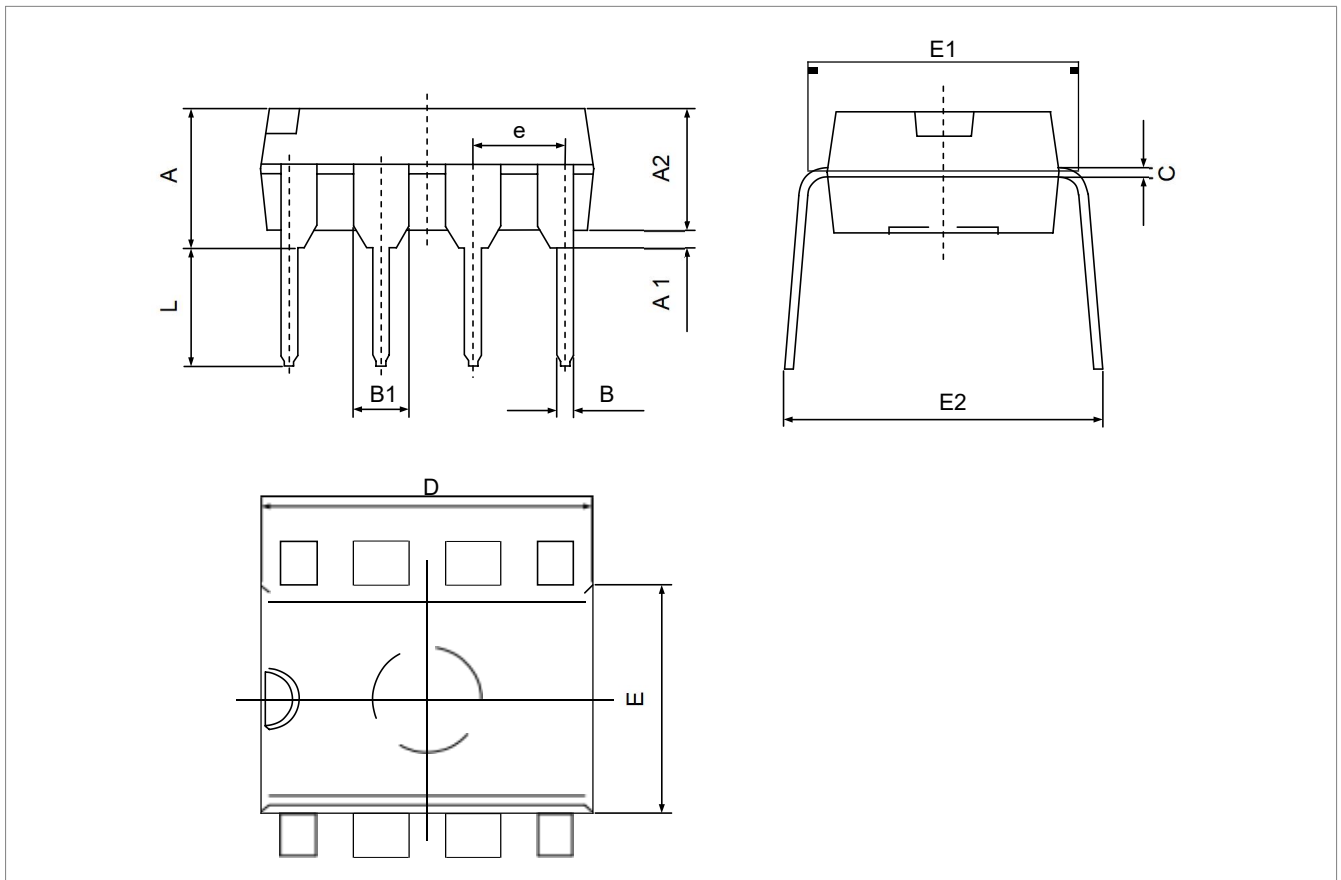

图 12 8-SOP 的封装示意图

表 8 8-SOP 的封装参数

符号	尺寸单位(毫米)		尺寸单位(英寸)	
	最小值	最大值	最小值	最大值
A	1.350	1.750	0.053	0.069
A1	0.100	0.250	0.004	0.010
A2	1.350	1.550	0.053	0.061
b	0.330	0.510	0.013	0.020
c	0.170	0.250	0.006	0.010
D	4.700	5.100	0.185	0.200
E	3.800	4.000	0.150	0.157
E1	5.800	6.200	0.228	0.244
e	0.127(BSC)		0.050(BSC)	
L	0.400	1.270	0.016	0.050
θ	0°	8°	0°	8°

■ 封装信息-MSOP

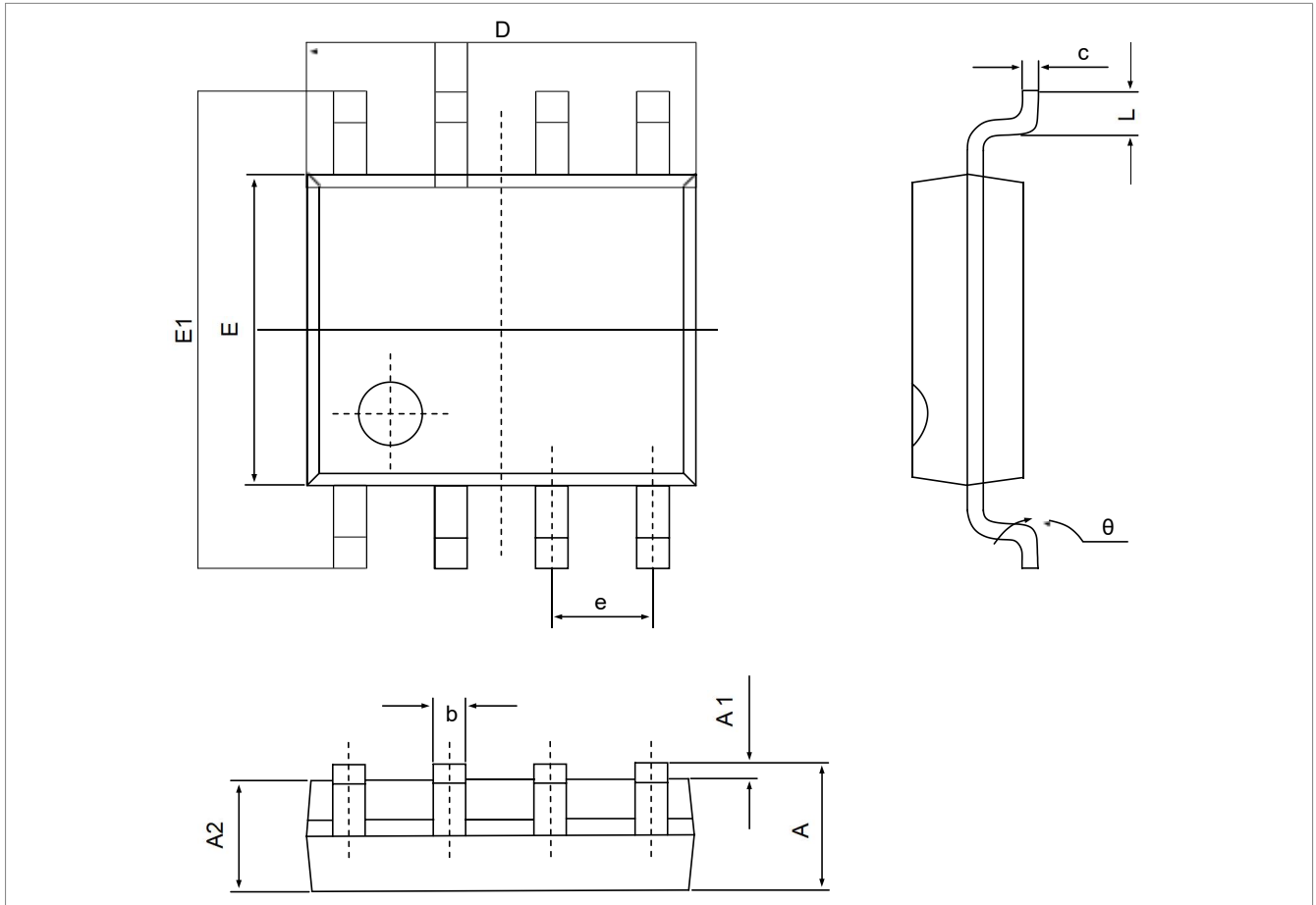

图 13 8-Micro SOP 的封装示意图

表 9 8-Micro SOP 的封装参数

符号	尺寸单位(毫米)		尺寸单位(英寸)	
	最小值	最大值	最小值	最大值
A	0.820	1.100	0.032	0.043
A1	0.020	0.150	0.001	0.006
A2	0.750	0.950	0.030	0.037
b	0.250	0.380	0.010	0.015
c	0.090	0.230	0.004	0.009
D	2.900	3.100	0.114	0.122
e	0.650(BSC)		0.026(BSC)	
E	2.900	3.100	0.114	0.122
E1	4.750	5.050	0.187	0.199
L	0.400	0.800	0.016	0.031
θ	0°	6°	0°	6°

■ 产品订购信息-706P/R/S/T
表 10 706P/R/S/T 芯片的订购信息

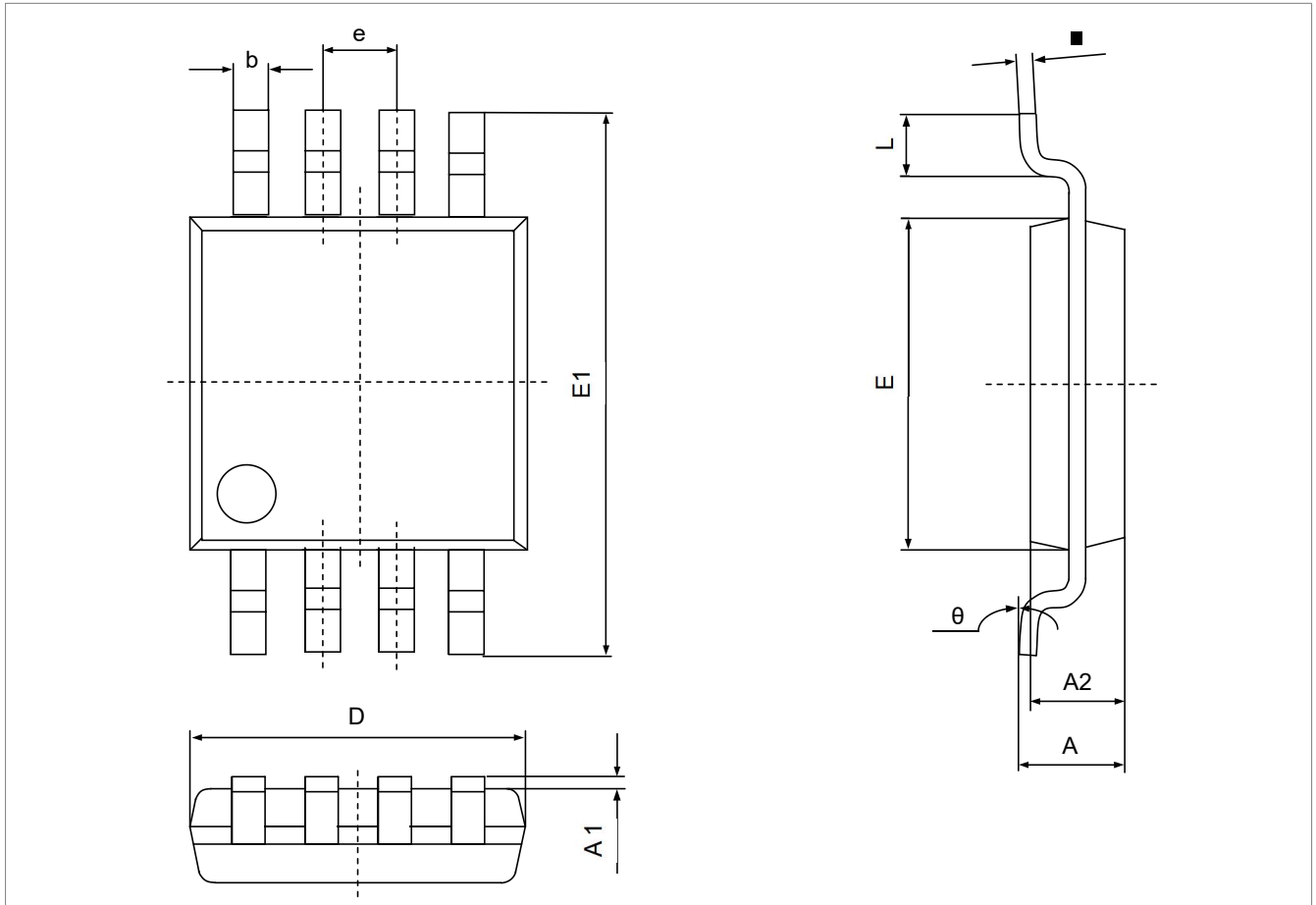
产品型号	封装类型	温度范围	复位阈值
706P 芯片复位输出为高电平，且具有看门狗功能。			
706PCPA	8- 引脚 DIP	0°C 至+70°C	2.63V
706PEPA		- 40°C 至+85°C	
706PCSA/T	8- 引脚 SOP	0°C 至+70°C	
706PESA/T		- 40°C 至+85°C	
706PCUA/T	8- 引脚 MSOP	0°C 至+70°C	
706R 芯片复位输出为低电平，且具有看门狗功能。			
706RCPA	8- 引脚 DIP	0°C 至+70°C	2.63V
706REPA		- 40°C 至+85°C	
706RCSA/T	8- 引脚 SOP	0°C 至+70°C	
706RESA/T		- 40°C 至+85°C	
706RCUA/T	8- 引脚 MSOP	0°C 至+70°C	
706S 芯片复位输出为低电平，且具有看门狗功能。			
706SCPA	8- 引脚 DIP	0°C 至+70°C	2.93V
706SEPA		- 40°C 至+85°C	
706SCSA/T	8- 引脚 SOP	0°C 至+70°C	
706SESA/T		- 40°C 至+85°C	
706SCUA/T	8- 引脚 MSOP	0°C 至+70°C	
706T 芯片复位输出为低电平，且具有看门狗功能。			
706TCPA	8- 引脚 DIP	0°C 至+70°C	3.08V
706TEPA		- 40°C 至+85°C	
706TCSA/T	8- 引脚 SOP	0°C 至+70°C	
706TESA/T		- 40°C 至+85°C	
706TCUA/T	8- 引脚 MSOP	0°C 至+70°C	

■ 产品订购信息-706J、708P/R/S/T
表 11 706J、708R/S/T 芯片的订购信息

产品型号	封装类型	温度范围	复位阈值
706J 芯片复位输出为低电平，且具有看门狗功能。			
706JCPA	8-引脚 DIP	0°C 至+70°C	4.00V
706JEPA		- 40°C 至+85°C	
706JCSA/T	8-引脚 SOP	0°C 至+70°C	
706JESA/T		- 40°C 至+85°C	
706JCUA/T	8-引脚 MSOP	0°C 至+70°C	
708R 芯片复位输出为高低电平都有效，但不具有看门狗功能。			
708RCPA	8-引脚 DIP	0°C 至+70°C	2.63V
708REPA		- 40°C 至+85°C	
708RCSA/T	8-引脚 SOP	0°C 至+70°C	
708RESA/T		- 40°C 至+85°C	
708RCUA/T	8-引脚 MSOP	0°C 至+70°C	
708S 芯片复位输出为高低电平都有效，但不具有看门狗功能。			
708SCPA	8-引脚 DIP	0°C 至+70°C	2.93V
708SEPA		- 40°C 至+85°C	
708SCSA/T	8-引脚 SOP	0°C 至+70°C	
708SESA/T		- 40°C 至+85°C	
708SCUA/T	8-引脚 MSOP	0°C 至+70°C	
708T 芯片复位输出为高低电平都有效，但不具有看门狗功能。			
708TCPA	8-引脚 DIP	0°C 至+70°C	3.08V
708TEPA		- 40°C 至+85°C	
708TCSA/T	8-引脚 SOP	0°C 至+70°C	
708TESA/T		- 40°C 至+85°C	
708TCUA/T	8-引脚 MSOP	0°C 至+70°C	

■ 产品订购信息-708J、705/6
表 12 708J、705/6 芯片的订购信息

产品型号	封装类型	温度范围	复位阈值
708J 芯片复位输出为高低电平都有效，但不具有看门狗功能。			
708JCPA70	8-引脚 DIP	0°C 至+70°C	4.00V
8JEPA		- 40°C 至+85°C	
708JCSA/T	8-引脚 SOP	0°C 至+70°C	
708JESA/T		- 40°C 至+85°C	
708JCUA/T	8-引脚 MSOP	0°C 至+70°C	
705 芯片复位输出为低电平，且具有看门狗功能。			
705CPA	8-引脚 DIP	0°C 至+70°C	4.65V
705EPA		- 40°C 至+85°C	
705CSA/T	8-引脚 SOP	0°C 至+70°C	
705ESA/T		- 40°C 至+85°C	
705CUA/T	8-引脚 MSOP	0°C 至+70°C	4.40V
705C/D	Dice	25°C	4.65V
706 芯片复位输出为低电平，且具有看门狗功能。			
706CPA	8-引脚 DIP	0°C 至+70°C	4.40V
706EPA		- 40°C 至+85°C	
706CSA/T	8-引脚 SOP	0°C 至+70°C	
706ESA/T		- 40°C 至+85°C	
706CUA/T	8-引脚 MSOP	0°C 至+70°C	
706C/D	Dice	25°C	

■ 产品订购信息-707/8、813L
表 13 707/8、813L 芯片的订购信息

产品型号	封装类型	温度范围	复位阈值
707 芯片复位输出为低或高电平，不具有看门狗功能。			
VP707CPA	8- 引脚 DIP	0°C 至+70°C	4.65V
VP707EPA		- 40°C 至+85°C	
707CSA/T	8- 引脚 SOP	0°C 至+70°C	
707ESA/T		- 40°C 至+85°C	
707CUA/T	8- 引脚 MSOP	0°C 至+70°C	
707C/D	Dice	25°C	
708 芯片复位输出为低或高电平，不具有看门狗功能。			
708CPA	8- 引脚 DIP	0°C 至+70°C	4.40V
708EPA		- 40°C 至+85°C	
708CSA/T	8- 引脚 SOP	0°C 至+70°C	
708ESA/T		- 40°C 至+85°C	
708CUA/T	8- 引脚 MSOP	0°C 至+70°C	
708C/D	Dice	25°C	
813L 芯片复位输出为高电平，且具有看门狗功能。			
813LCPA	8- 引脚 DIP	0°C 至+70°C	4.65V
813LEPA		- 40°C 至+85°C	
813LCSA/T	8- 引脚 SOP	0°C 至+70°C	
813LESA/T		- 40°C 至+85°C	
813LCUA/T	8- 引脚 MSOP	0°C 至+70°C	
813LC/D	Dice	25°C	

Attention

- Any and all MSKSEMI Semiconductor products described or contained herein do not have specifications that can handle applications that require extremely high levels of reliability, such as life-support systems, aircraft's control systems, or other applications whose failure can be reasonably expected to result in serious physical and/or material damage. Consult with your MSKSEMI Semiconductor representative nearest you before using any MSKSEMI Semiconductor products described or contained herein in such applications.
- MSKSEMI Semiconductor assumes no responsibility for equipment failures that result from using products at values that exceed, even momentarily, rated values (such as maximum ratings, operating condition ranges, or other parameters) listed in products specifications of any and all MSKSEMI Semiconductor products described or contained herein.
- Specifications of any and all MSKSEMI Semiconductor products described or contained herein stipulate the performance, characteristics, and functions of the described products in the independent state, and are not guarantees of the performance, characteristics, and functions of the described products as mounted in the customer's products or equipment. To verify symptoms and states that cannot be evaluated in an independent device, the customer should always evaluate and test devices mounted in the customer's products or equipment.
- MSKSEMI Semiconductor strives to supply high-quality high-reliability products. However, any and all semiconductor products fail with some probability. It is possible that these probabilistic failures could give rise to accidents or events that could endanger human lives, that could give rise to smoke or fire, or that could cause damage to other property. When designing equipment, adopt safety measures so that these kinds of accidents or events cannot occur. Such measures include but are not limited to protective circuits and error prevention circuits for safe design, redundant design, and structural design.
- In the event that any or all MSKSEMI Semiconductor products (including technical data, services) described or contained herein are controlled under any of applicable local export control laws and regulations, such products must not be exported without obtaining the export license from the authorities concerned in accordance with the above law.
- No part of this publication may be reproduced or transmitted in any form or by any means, electronic or mechanical, including photocopying and recording, or any information storage or retrieval system, or otherwise, without the prior written permission of MSKSEMI Semiconductor.
- Information (including circuit diagrams and circuit parameters) herein is for example only ; it is not guaranteed for volume production. MSKSEMI Semiconductor believes information herein is accurate and reliable, but no guarantees are made or implied regarding its use or any infringement of intellectual property rights or other rights of third parties.
- Any and all information described or contained herein are subject to change without notice due to product/technology improvement, etc. When designing equipment, refer to the "Delivery Specification" for the MSKSEMI Semiconductor product that you intend to use.

X-ON Electronics

Largest Supplier of Electrical and Electronic Components

Click to view similar products for [Supervisory Circuits](#) category:

Click to view products by [MSKSEMI](#) manufacturer:

Other Similar products are found below :

[CAT1161LI-25-G](#) [CAT853STBI-T3](#) [DS1232L](#) [NCV302HSN45T1G](#) [STM6710FWB7F](#) [S-1000N28-I4T1U](#) [S-1000N23-I4T1U](#) [S-1000N19-I4T1U](#) [PT7M6133NLTA3EX](#) [PT7M6127NLTA3EX](#) [ISL88708IB829Z](#) [ISL88011IH526Z-TK](#) [ISL88013IH529Z-TK](#) [ISL88705IP846Z](#) [ISL88706IP831Z](#) [ISL88708IB844Z](#) [ISL88708IP831Z](#) [TCM811MERCCTR](#) [X40420S14-A](#) [X40421S14-C](#) [X40430S14-A](#) [X40430S14I-A](#) [X40430S14I-B](#) [X40431S14-A](#) [X40431S14-B](#) [X40431S14-C](#) [X40431S14I-A](#) [X40431S14I-B](#) [X40431S14I-C](#) [X4043P-2.7](#) [X4043PI-2.7](#) [X4043S8-2.7T1](#) [X4043S8IZ-2.7](#) [X4043S8IZT1](#) [X4043S8T1](#) [X4045P](#) [X4045PI](#) [X4045PI-2.7](#) [X4045S8-2.7T1](#) [X4045S8IZ](#) [X4045S8T1](#) [X4163P](#) [X4163P-2.7](#) [X4163PI](#) [X4163PI-2.7](#) [X4163S8](#) [X4165P](#) [X4165P-2.7](#) [X4165PI](#) [X4165PI-2.7](#)