

# MSKSEMI 美森科

SEMICONDUCTOR



ESD



TVS



TSS



MOV



GDT



PLED



## MMBT3906M

Product specification

## General Features

Capable of 100 mWatts of Power Dissipation and 200mA Ic  
 Operating and Storage Junction Temperatures: -55°C to 150°C  
 Small Outline Surface Mount Package  
 RoHS compliant / Green EMC

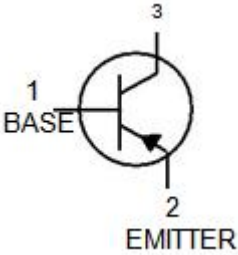
## Reference News

PACKAGE OUTLINE	Foot position analysis	Marking
 <p>SOT-723</p>		

## MAXIMUM RATINGS (Ta=25°C unless otherwise noted)

Symbol	Parameter	Value	Unit
VCBO	Collector-Base Voltage	-40	V
VCEO	Collector-Emitter Voltage	-40	V
VEBO	Emitter-Base Voltage	-5	V
IC	Collector Current -Continuous	-0.2	A
PC	Collector Power Dissipation	100	mW
Rθ JA	Thermal Resistance From Junction To Ambient	1250	°C/W
Tj	Junction Temperature	150	°C
Tstg	Storage Temperature	-55~+150	°C

**ELECTRICAL CHARACTERISTICS @ 25°C Unless Otherwise Specified**

Symbol	Parameter	Test Conditions	Min	Max	Units
VCEO	Collector-Emitter Breakdown Voltage	IC=-1.0mA, IB=0	-40		V
VCBO	Collector-Base Breakdown Voltage	IC=-10μA, IE=0	-40		V
VEBO	Emitter-Base Breakdown Voltage	IE=-10μA, IC=0	-5		V
ICBO	Collector Cut-off Current	VCB=-40V, IE=0		-100	nA
ICEX	Collector Cut-off Current	VCE=-30V, VEB(OFF)=-3.0V		-50	nA
IEBO	Emitter Cut-off Current	VEB=-5V, IC=0		-100	nA
hFE(1)	DC Current Gain	IC=-10mA, VCE=-1V	100	300	
hFE(2)	DC Current Gain	IC=-50mA, VCE=-1V	60		
hFE(3)	DC Current Gain	IC=-100mA, VCE=-2V	30		
VCE(sat)	Collector-Emitter Saturation Voltage	IC=-50mA, IB=-5mA		-0.3	V
VBE(sat)	Base-Emitter Saturation Voltage	IC=-50mA, IB=-5mA		-0.95	V
fT	Current Gain-Band width Product	IC=-10mA, VCE=-20V, f=100MHz	300		MHz
td	Delay Time	VCC=-3.0V, VBE(off)=-0.5V		35	ns
tr	Rise Time	IC=-10mA, IB1=IB2=-1.0mA		35	ns
ts	Storage Time	VCC=-3.0V, IC=-10mA		225	ns
tf	Fall Time	IB1=IB2=-1.0mA		75	ns

**TYPICAL CHARACTERISTICS**

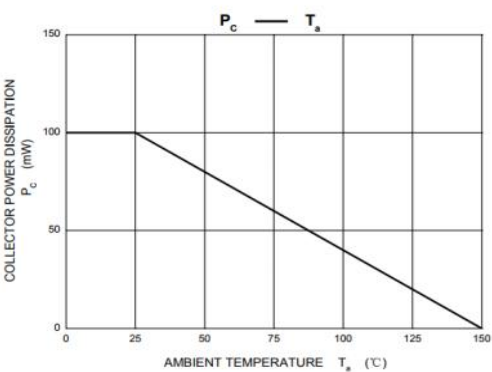
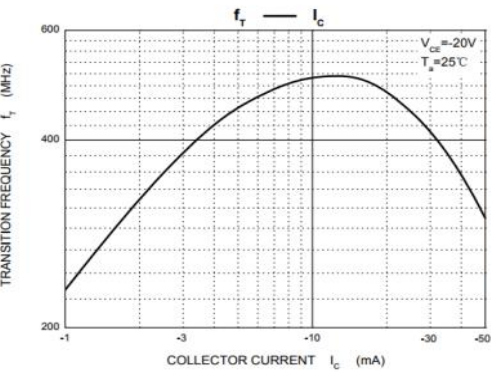
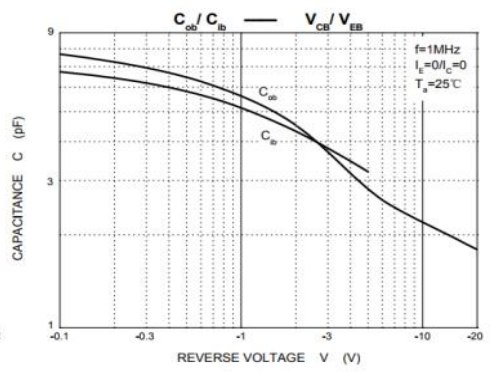
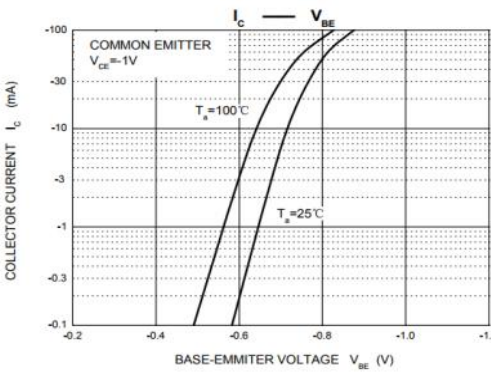
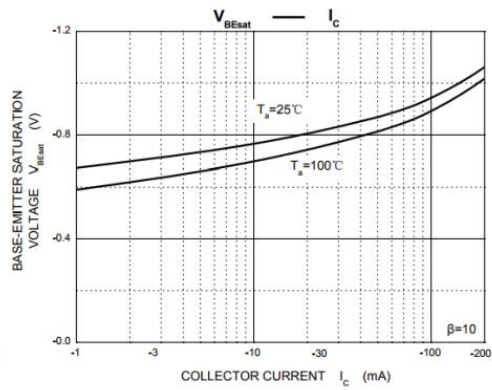
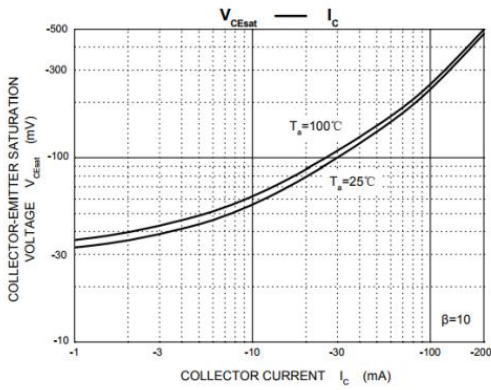
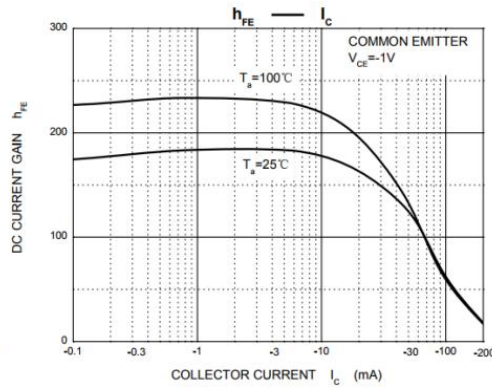
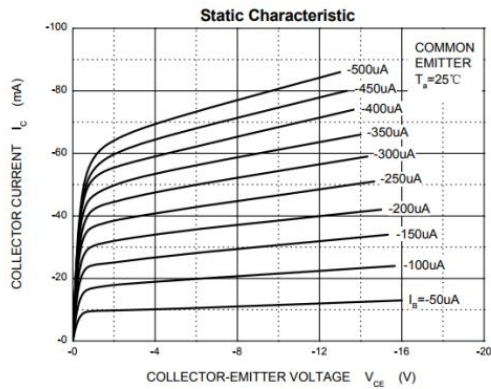

**PACKAGE MECHANICAL DATA**

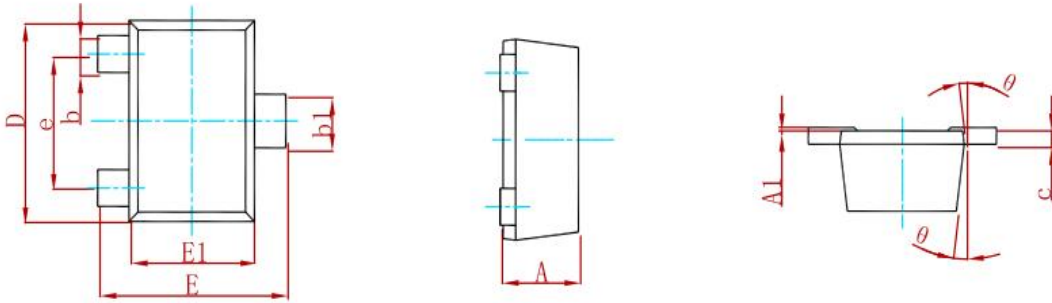

Symbol	Dimensions In Millimeters		Dimensions In Inches	
	Min.	Max.	Min.	Max.
A	0.430	0.500	0.017	0.020
A1	0.000	0.050	0.000	0.002
b	0.170	0.270	0.007	0.011
b1	0.270	0.370	0.011	0.015
c	0.080	0.150	0.003	0.006
D	1.150	1.250	0.045	0.049
E	1.150	1.250	0.045	0.049
E1	0.750	0.850	0.030	0.033
e	0.800TYP		0.031TYP	
θ	7° REF.		7° REF.	

**Suggested Pad Layout**

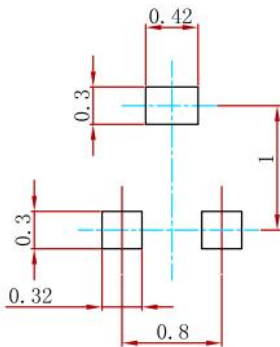

Note:

1. Controlling dimension: in millimeters.
2. General tolerance: ±0.05mm.
3. The pad layout is for reference purposes only.

**REEL SPECIFICATION**

P/N	PKG	QTY
MMBT3906M	SOT-723	8000

## Attention

- Any and all MSKSEMI Semiconductor products described or contained herein do not have specifications that can handle applications that require extremely high levels of reliability, such as life-support systems, aircraft's control systems, or other applications whose failure can be reasonably expected to result in serious physical and/or material damage. Consult with your MSKSEMI Semiconductor representative nearest you before using any MSKSEMI Semiconductor products described or contained herein in such applications.
- MSKSEMI Semiconductor assumes no responsibility for equipment failures that result from using products at values that exceed, even momentarily, rated values (such as maximum ratings, operating condition ranges, or other parameters) listed in products specifications of any and all MSKSEMI Semiconductor products described or contained herein.
- Specifications of any and all MSKSEMI Semiconductor products described or contained herein stipulate the performance, characteristics, and functions of the described products in the independent state, and are not guarantees of the performance, characteristics, and functions of the described products as mounted in the customer's products or equipment. To verify symptoms and states that cannot be evaluated in an independent device, the customer should always evaluate and test devices mounted in the customer's products or equipment.
- MSKSEMI Semiconductor strives to supply high-quality high-reliability products. However, any and all semiconductor products fail with some probability. It is possible that these probabilistic failures could give rise to accidents or events that could endanger human lives, that could give rise to smoke or fire, or that could cause damage to other property. When designing equipment, adopt safety measures so that these kinds of accidents or events cannot occur. Such measures include but are not limited to protective circuits and error prevention circuits for safe design, redundant design, and structural design.
- In the event that any or all MSKSEMI Semiconductor products (including technical data, services) described or contained herein are controlled under any of applicable local export control laws and regulations, such products must not be exported without obtaining the export license from the authorities concerned in accordance with the above law.
- No part of this publication may be reproduced or transmitted in any form or by any means, electronic or mechanical, including photocopying and recording, or any information storage or retrieval system, or otherwise, without the prior written permission of MSKSEMI Semiconductor.
- Information (including circuit diagrams and circuit parameters) herein is for example only ; it is not guaranteed for volume production. MSKSEMI Semiconductor believes information herein is accurate and reliable, but no guarantees are made or implied regarding its use or any infringements of intellectual property rights or other rights of third parties.
- Any and all information described or contained herein are subject to change without notice due to product/technology improvement, etc. When designing equipment, refer to the "Delivery Specification" for the MSKSEMI Semiconductor product that you intend to use.

## X-ON Electronics

Largest Supplier of Electrical and Electronic Components

*Click to view similar products for [Bipolar Transistors - BJT category](#):*

*Click to view products by [MSKSEMI manufacturer](#):*

Other Similar products are found below :

[BC559C](#) [MCH4017-TL-H](#) [MMBT-2369-TR](#) [BC546/116](#) [NJVMJD148T4G](#) [NTE16](#) [NTE195A](#) [IMX9T110](#) [2N4401-A](#) [2N4403](#) [2N6728](#)  
[2SA1419T-TD-H](#) [2SA2126-E](#) [2SB1204S-TL-E](#) [FMC5AT148](#) [2N2369ADCSM](#) [2N2907A](#) [2N3904-NS](#) [2N5769](#) [2SC4618TLN](#) [CPH6501-](#)  
[TL-E](#) [MCH4021-TL-E](#) [Jantx2N5416](#) [US6T6TR](#) [BAX18/A52R](#) [BC556/112](#) [IMZ2AT108](#) [MMST8098T146](#) [UMX21NTR](#) [MCH6102-TL-E](#)  
[TTA1452B,S4X\(S](#) [2N3879](#) [NTE13](#) [NTE282](#) [NTE323](#) [NTE350](#) [NTE81](#) [JANTX2N2920L](#) [JANTX2N3735](#) [JANSR2N2222AUB](#)  
[CMLT3946EG TR](#) [SNSS40600CF8T1G](#) [CMLT3906EG TR](#) [GRP-DATA-JANS2N2907AUB](#) [GRP-DATA-JANS2N2222AUA](#)  
[MMDT3946FL3-7](#) [2N4240](#) [JANS2N3019](#) [MSB30KH-13](#) [2N2221AUB](#)