

MSKSEMI 美森科

SEMICONDUCTOR



ESD



TVS



TSS



MOV



GDT



PLED

NE555

产品手册

产品简介

NE555 是一款能产生高精度定时脉冲的双极性集成电路。内部包括阈值比较器、触发比较器、RS 触发器、输出电路等四部分电路构成。它可通过外接少量的阻容器件，组成定时触发电路、脉宽调制电路、音频振荡器等等电路。广泛应用于玩具、信号交通、自动化控制等等领域。



产品特点

- 定时精度高
- 输出驱动能力强
- 温度稳定性好
- 最大工作频率可达 500KHZ 以上
- 可与 TTL 电路兼容
- 定时时间可从微秒级到小时级(可通过外接电阻电容精确控制)
- 封装形式:SOP-8、DIP-8

产品用途

- 音频脉冲发生器、分频器
- 设备定时，交通灯控制、门禁控制
- 脉宽调制，脉冲相位调制
- 工业控制

参考信息

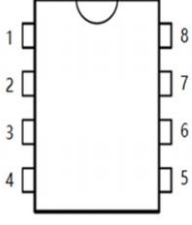
封装图		DIP-8/SOP-8
		
SOP-8	DIP-8	管脚功能定义

管脚序号	管脚定义	管脚功能描述
1	GND	电源地
2	Trig	触发
3	Output	输出
4	Reset	复位
5	Cont	控制电压
6	Thres	阈值
7	Disch	放电
8	VCC	电源正

订单信息

P/N	PKG	QTY
NE555P-MS	DIP-8	1000PCS
NE555DR-MS	SOP-8	2500PCS

极限参数

参数	符号	极限值	单位
电源电压	VCC	18	V
输入电压	VI (thre, trig, cont, reset)	VCC	V
输出电流	Io	±220	mA
耗散功率	PD	400	mW
工作温度	TA	-20~70	°C
储存温度	TS	-65~150	°C
焊接温度	TW	260, 10s	°C

注：极限参数是指无论在任何条件下都不能超过的极限值。如果超过此极限值，将有可能造成产品劣化等物理性损伤；同时在接近极限参数下，不能保证芯片可以正常工作。

原理框图

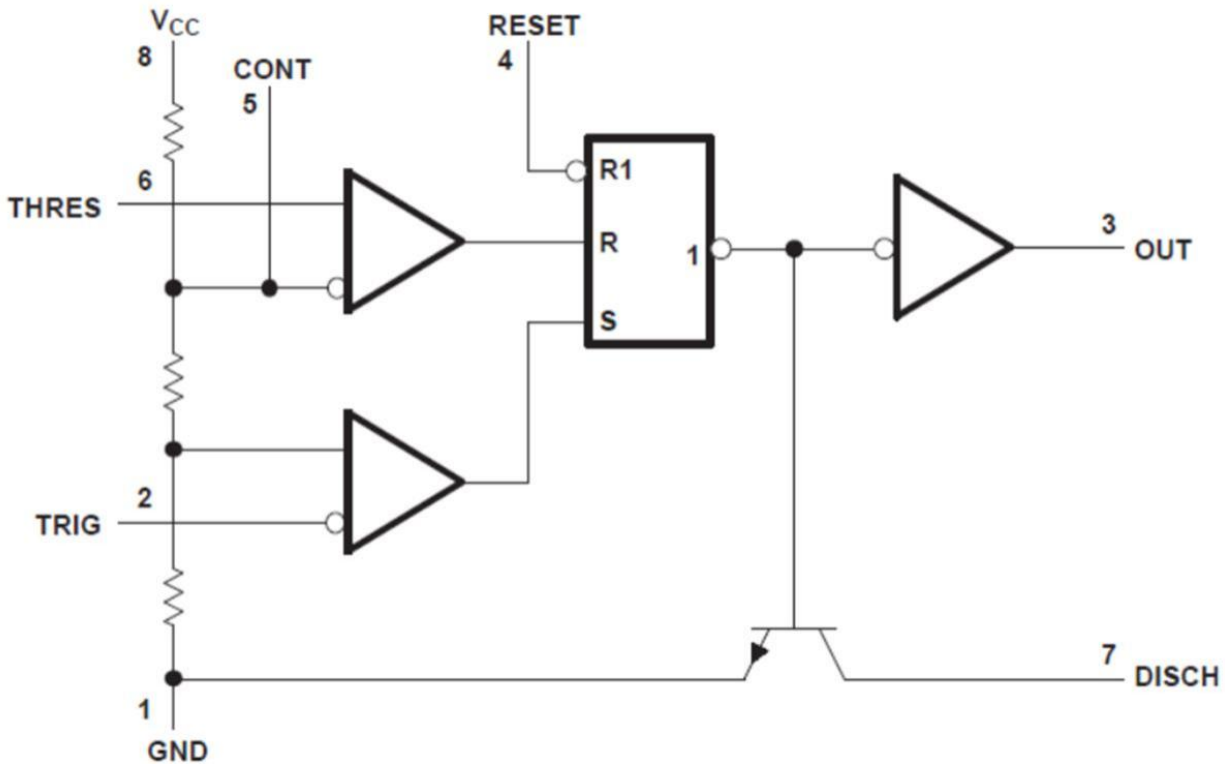

推荐电学参数

项目	符号	参数值	单位
电源电压	VCC	4.5~15	V
最大输入电压	Vth, Vtrig, Vcont, Vreset	VCC	V
输出电流	Io	±200	mA

电学特性 ($T_A=25^{\circ}\text{C}$, 除非特别指定)

项目	符号	条件	最小值	典型值	最大值	单位
工作电压	V_{CC}		4.5	-	15	V
工作电流	I_{CC}	$V_{CC}=5\text{V}, R_L=\infty, V_O=V_{OL}$	-	3	6	mA
		$V_{CC}=5\text{V}, R_L=\infty, V_O=V_{OH}$	-	1.5	5	mA
		$V_{CC}=15\text{V}, R_L=\infty, V_O=V_{OL}$	-	8	15	mA
		$V_{CC}=15\text{V}, R_L=\infty, V_O=V_{OH}$	-	6	13	mA
控制端电压	V_{CL}	$V_{CC}=15\text{V}$	-	10.0	11	V
		$V_{CC}=5\text{V}$	-	3.3	4	V
阈值电压端电压	V_{TH}	$V_{CC}=15\text{V}$	-	10.0	11.2	V
		$V_{CC}=5\text{V}$	-	3.3	4.2	V
阈值电压电流	I_{TH}^{*note1}	$V_{CC}=15\text{V}, V_{TH}=0\text{V}$	-	-	250	nA
触发端电压	V_{TRIG}	$V_{CC}=15\text{V}$	-	5.0	5.6	V
		$V_{CC}=5\text{V}$	-	1.6	2.2	V
触发端电流	I_{TRIG}	$V_{CC}=15\text{V}, V_{TRIG}=0\text{V}$,	-	-	2	uA
复位端高电压	V_{RESETH}	$V_{CC}=5\text{V}$	1.5	-	V_{CC}	V
复位端低电压	V_{RESETL}	$V_{CC}=5\text{V}$	GND	-	0.5	V
复位端电流	I_{RESET}	$V_{RESET}=0.4\text{V}, V_{CC}=15\text{V}$	-	0.13	0.4	mA
		$V_{RESET}=0\text{V}, V_{CC}=15\text{V}$	-	0.3	1.5	mA
输出低电压	V_{OL}	$V_{CC}=15\text{V}, I_L=-5\text{mA}$	-	0.02	0.25	V
		$V_{CC}=15\text{V}, I_L=-50\text{mA}$	-	0.04	0.75	
		$V_{CC}=15\text{V}, I_L=-100\text{mA}$	-	2.0	2.5	
		$V_{CC}=15\text{V}, I_L=-200\text{mA}$	-	2.8	-	
		$V_{CC}=5\text{V}, I_L=-5\text{mA}$	-	0.08	0.35	
		$V_{CC}=5\text{V}, I_L=-8\text{mA}$	-	0.15	0.4	
输出高电压	V_{OH}	$V_{CC}=15\text{V}, I_L=-100\text{mA}$	12.75	13.3	-	V
		$V_{CC}=15\text{V}, I_L=-200\text{mA}$	-	12.2	-	
		$V_{CC}=5\text{V}, I_L=-100\text{mA}$	2.75	3.3	-	
放电管关闭漏电流	$I_{dis(off)}$	$V_O=V_{OH}, V_{dis}=10\text{V}$	-	-	100	nA

电学特性($T_A=25^{\circ}\text{C}$ ，除非特别指定)

项目	符号	条件		最小值	典型值	最大值	单位
放电管饱和电压	Vdis(sat)	VO=VOL	VCC=15V, Idis=15mA	-	140	48	mV
			VCC=5V, Idis=4.5mA	-	100	200	mV
输出上升沿时间	tR	CL=15pF,		-	80	300	ns
输出下降沿时间	tF	CL=15pF		-	50	300	ns
定时误差 (单稳态)	Ts*note2	RA=2k Ω 至	VCC=15V, 初始误差	-	1	-	%
	Tv	100k Ω	随电源电压漂移 (4.5V~15V)	-	0.1	-	%/V
	Tt	C=0.1uF	VCC=15V, 随温度漂移(0~60 $^{\circ}\text{C}$)	-	150	-	ppm $^{\circ}\text{C}$
定时误差 (非稳态)	Ts*note2	RA、RB=1k Ω	VCC=15V, 初始误差	-	1	-	%
	Tv	Ω 至 100k Ω	随电源电压漂移(4.5V~15V)	-	0.1	-	%/V
	Tt	Ω C=0.1uF	VCC=15V, 随温度漂移(0~60 $^{\circ}\text{C}$)	-	150	-	ppm $^{\circ}\text{C}$

典型应用线路

1、单稳态:

在单稳态模式下，当输入电平达到 $1/3 V_{CC}$ 时，电路触发输出高电平，并保持 $t=1.1*RA*C$ 时间后，输出变为低电平。在 t 时间内，无论输入电平是什么状态，输出状态不受影响。电路及波形见图 3 和图 4。



图 3 单稳态电路



图4 单稳态波形图

2、非稳态:

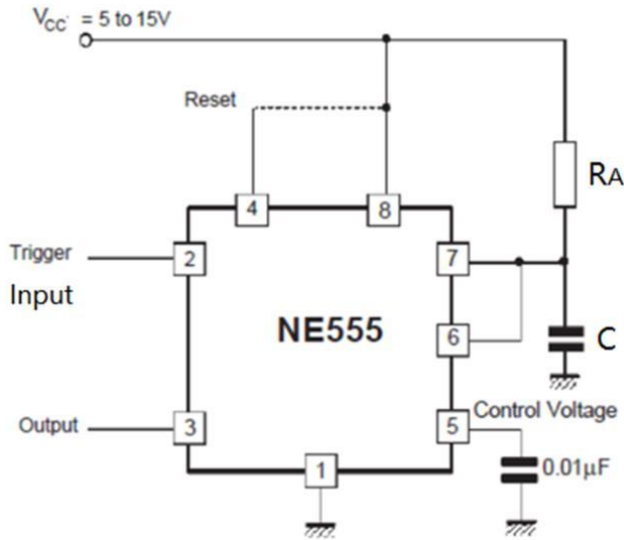
在非稳态模式下，电路会自动触发，输出为方波的多谐振荡器。其输出方波频率和占空比，可通过 R_A 、 R_B 、 C 大小进行调节。其触发模式、充电和放电时间以及频率与电源电压无关。电路及波形见图 5 和图 6。输出高电平脉宽 $t_h=0.693*(R_A+R_B)*C$ ；低电平脉宽 $t_l=0.693*R_B*C$ ； $T=t_h+t_l=0.693*(R_A+2R_B)*C$ ；频率 $f=1/T=1.44/(R_A*C+2R_B*C)$ ；占空比 $D=t_l/T=R_B/(R_A+2R_B)$ 。

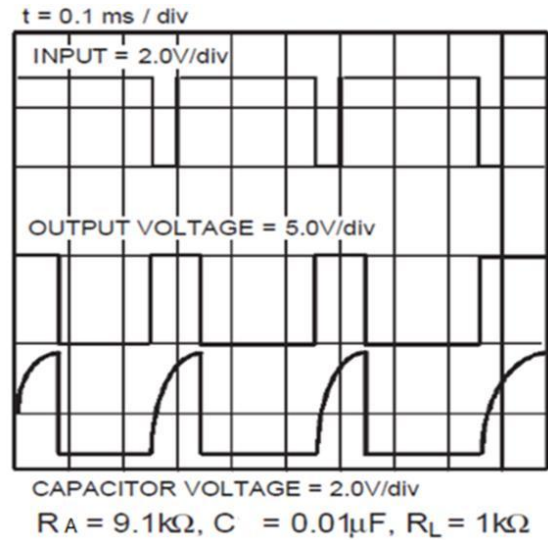

图 5 非稳态电路



图 6 非稳态波形图

3、脉宽调制：

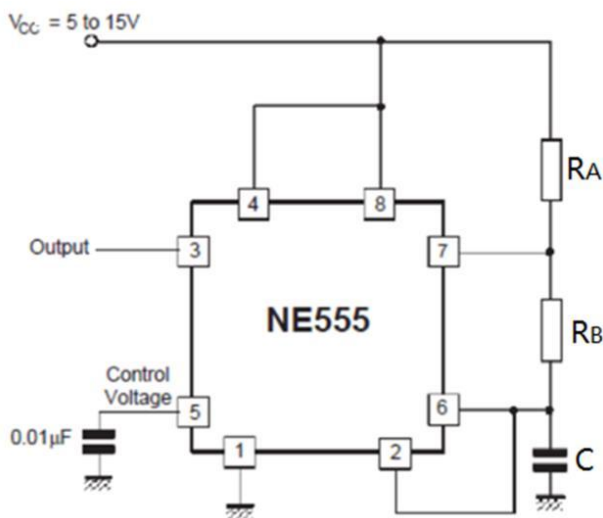
当定时器以单稳态模式连接，并由连续脉冲串施加到引脚 2 触发时，输出脉冲宽度可由施加到引脚 5 的信号进行调制。见图 7、图 8。

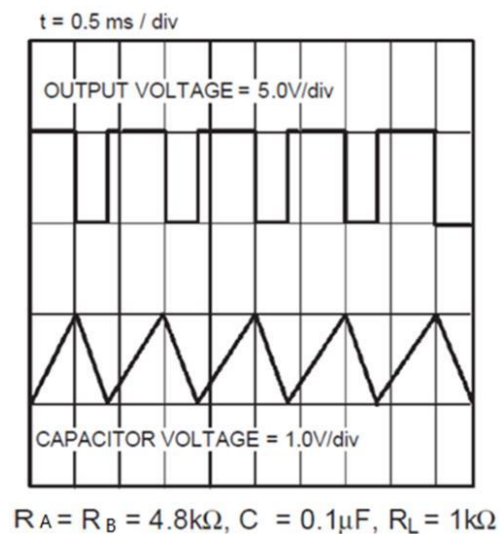

图 7 脉宽调制电路



图 8 脉宽调制电路波形图

4、脉冲位置调制：

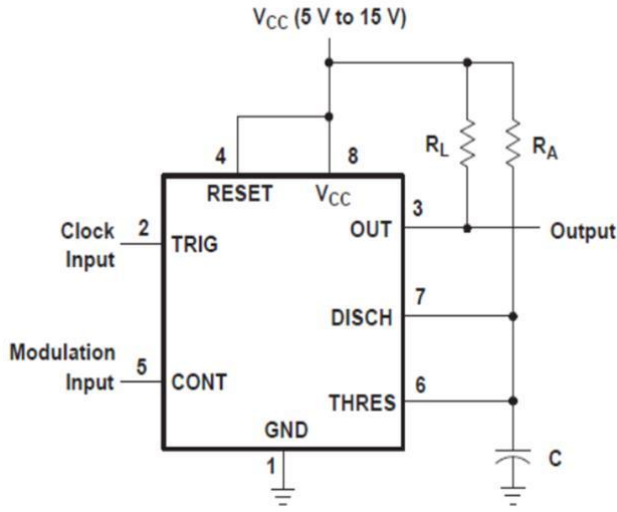
当定时器以图 9 方式连接，输出脉冲位置可由施加到引脚 5 的信号进行调制。见图 9、图 10。

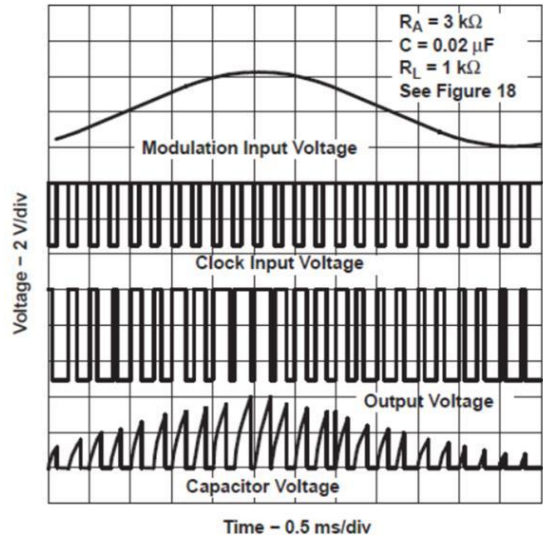

图 9 脉冲位置调制电路



图 10 脉冲位置调制电路波形图

PACKAGE MECHANICAL DATA

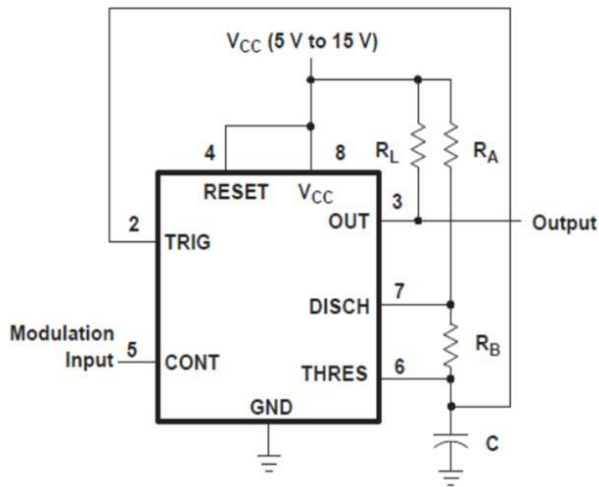
DIP-8

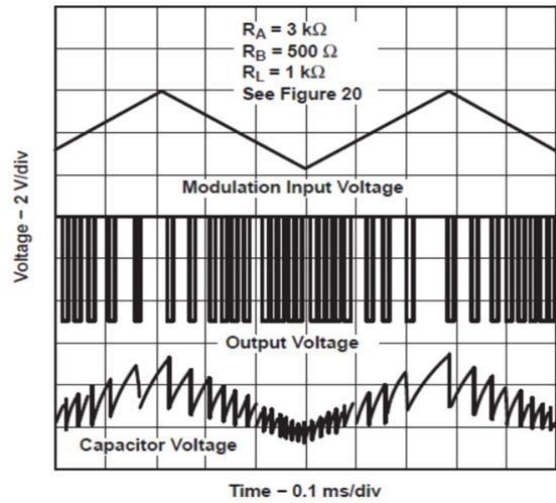
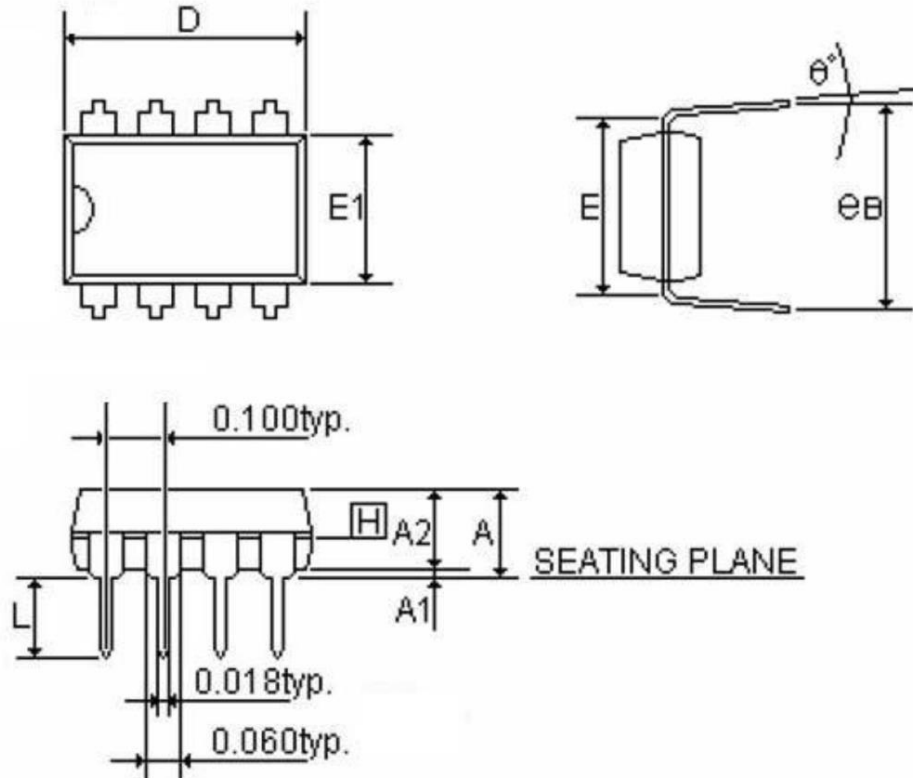

SYMBOLS	MIN	NOR	MAX	MIN	NOR	MAX
	(inch)			(mm)		
A	-	-	0.210	-	-	5.334
A1	0.015	-	-	0.381	-	-
A2	0.125	0.130	0.135	3.175	3.302	3.429
D	0.435	0.455	0.475	15.669	16.050	16.685
E	0.300			7.62		
E1	0.245	0.250	0.255	6.223	6.35	6.477
L	0.115	0.130	0.150	2.921	3.302	3.810
e B	0.335	0.355	0.375	8.509	9.017	9.525
θ°	0°	7°	15°	0°	7°	15°

PACKAGE MECHANICAL DATA

SOP-8

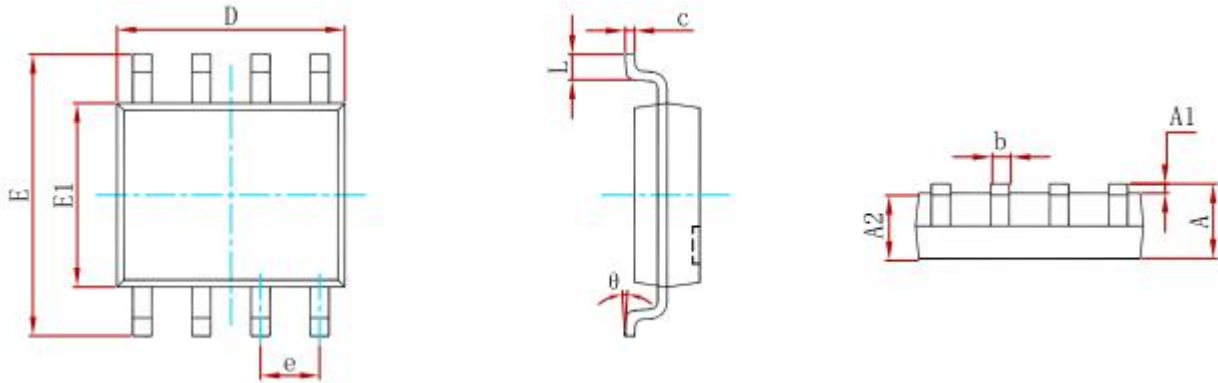

Symbol	Dimensions In Millimeters		Dimensions In Inches	
	Min	Max	Min	Max
A	1.350	1.750	0.053	0.069
A1	0.100	0.250	0.004	0.010
A2	1.350	1.550	0.053	0.061
b	0.330	0.510	0.013	0.020
c	0.170	0.250	0.007	0.010
D	4.800	5.000	0.189	0.197
e	1.270 (BSC)		0.050 (BSC)	
E	5.800	6.200	0.228	0.244
E1	3.800	4.000	0.150	0.157
L	0.400	1.270	0.016	0.050
θ	0°	8°	0°	8°

Suggested Pad Layout

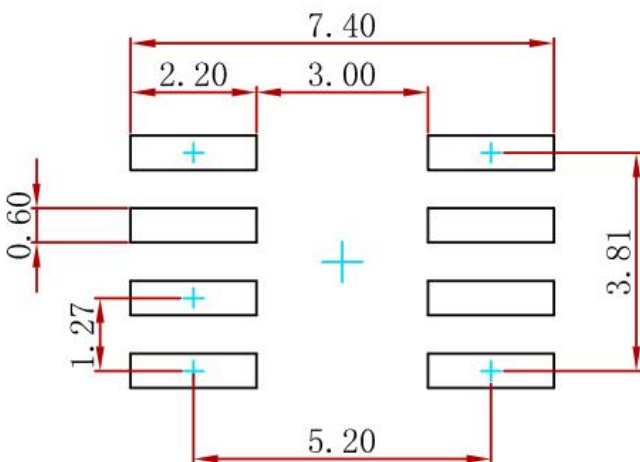

Note:

1. Controlling dimension: in millimeters.
2. General tolerance: ±0.05mm.
3. The pad layout is for reference purposes only.

Attention

- Any and all MSKSEMI Semiconductor products described or contained herein do not have specifications that can handle applications that require extremely high levels of reliability, such as life-support systems, aircraft's control systems, or other applications whose failure can be reasonably expected to result in serious physical and/or material damage. Consult with your MSKSEMI Semiconductor representative nearest you before using any MSKSEMI Semiconductor products described or contained herein in such applications.
- MSKSEMI Semiconductor assumes no responsibility for equipment failures that result from using products at values that exceed, even momentarily, rated values (such as maximum ratings, operating condition ranges, or other parameters) listed in products specifications of any and all MSKSEMI Semiconductor products described or contained herein.
- Specifications of any and all MSKSEMI Semiconductor products described or contained herein stipulate the performance, characteristics, and functions of the described products in the independent state, and are not guarantees of the performance, characteristics, and functions of the described products as mounted in the customer's products or equipment. To verify symptoms and states that cannot be evaluated in an independent device, the customer should always evaluate and test devices mounted in the customer's products or equipment.
- MSKSEMI Semiconductor strives to supply high-quality high-reliability products. However, any and all semiconductor products fail with some probability. It is possible that these probabilistic failures could give rise to accidents or events that could endanger human lives, that could give rise to smoke or fire, or that could cause damage to other property. When designing equipment, adopt safety measures so that these kinds of accidents or events cannot occur. Such measures include but are not limited to protective circuits and error prevention circuits for safe design, redundant design, and structural design.
- In the event that any or all MSKSEMI Semiconductor products (including technical data, services) described or contained herein are controlled under any of applicable local export control laws and regulations, such products must not be exported without obtaining the export license from the authorities concerned in accordance with the above law.
- No part of this publication may be reproduced or transmitted in any form or by any means, electronic or mechanical, including photocopying and recording, or any information storage or retrieval system, or otherwise, without the prior written permission of MSKSEMI Semiconductor.
- Information (including circuit diagrams and circuit parameters) herein is for example only ; it is not guaranteed for volume production. MSKSEMI Semiconductor believes information herein is accurate and reliable, but no guarantees are made or implied regarding its use or any infringement of intellectual property rights or other rights of third parties.
- Any and all information described or contained herein are subject to change without notice due to product/technology improvement, etc. When designing equipment, refer to the "Delivery Specification" for the MSKSEMI Semiconductor product that you intend to use.

X-ON Electronics

Largest Supplier of Electrical and Electronic Components

Click to view similar products for [Timers](#) category:

Click to view products by [MSKSEMI](#) manufacturer:

Other Similar products are found below :

[H5S-WFB2D](#) [304E-007-A-00-PX](#) [305E-015-A-1-0-PX](#) [THR2U-110A](#) [81506944](#) [H7AN-RT6M AC100-240](#) [711-0131](#) [600DT-CU](#)
[1SVR508130R0000](#) [1SVR730100R3100](#) [H3Y-2 AC24 10S](#) [81503028](#) [722-0001](#) [732-0023](#) [80.01.0.240.0000T](#) [81.01.0.230.0000T](#)
[88.92.0.240.0000](#) [12.A4.8.230.0010](#) [85.03.0.024.0000](#) [80.61.0.240.0000T](#) [LTR10](#) [SL555D](#) [SA555DR-HXY](#) [NE555P-HXY](#) [KG316T-D](#)
[AC220V](#) [JSZ3A-E AC220V](#) [JSZ3A-F AC220V](#) [JSS48A-2Z AC/DC24V-48V](#) [JSZ3C-B AC220V](#) [JSZ6-2 10s DC24V](#) [JSZ6-2 60s DC24V](#)
[JSZ3Y 30s AC220V](#) [JS14P 999s AC220V](#) [JS14P 99s AC220V](#) [KG10M AC220V](#) [JSZ3A-A AC220V](#) [JSZ3A-B DC24V](#) [JSS48A-2Z AC220V](#)
[JSZ6-2 10s AC220V](#) [JSZ3F 30s AC220V](#) [JZF-07 AC220V](#) [JSZ3A-B AC220V](#) [JS14P 99s AC380V](#) [JSZ3F 60s AC220V](#) [710037400000004](#)
[NKG3-M AC220V](#) [JSZ3A-D AC220V](#) [JSZ6-2 60s AC220V](#) [KG10D-1H AC220V](#) [JSS48A AC220V](#)