

# MSKSEMI 美森科

SEMICONDUCTOR



ESD



TVS



TSS



MOV



GDT



PLED

## XC6201PXXXXX-MS

### Product specification

## GENERAL DESCRIPTION

XC6201PXXXX-MS series are a set of Low Dropout LinearRegulator ICs implemented in CMOS technology. They can withstand voltage 10V. And they areavailable with low voltage drop and low quiescentcurrent,widely used in audio,video and communication appliances.

## FEATURES

- Low Power Consumption
- Low Voltage Drop
- Low Temperature Coefficient
- Withstanding Voltage 12V
- Quiescent Current 2.0μA
- Output Voltage Accuracy: tolerance ±2%
- High output current: 300mA

## TYPICALAPPLICATIONS

- Battery-poweredEquipments
- CommunicationEquipments
- Audio/VideoEquipments
- SmartBattery Packs
- Smoke Detectors
- CO2 DETECTORS

## PACKAGE/ORDERINFORMATION

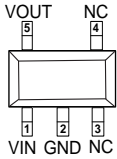
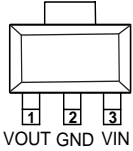
Part Number	Package	Pin Configuration	Marking	QTY
XC6201P252MR-MS	SOT-23-5L		15T*	3000
XC6201P302MR-MS			15Z*	3000
XC6201P332MR-MS			162*	3000
XC6201P362MR-MS			165*	3000
XC6201P502MR-MS			16M*	3000
XC6201P252PR-MS	SOT-89-3		15 T*	1000
XC6201P302PR-MS			15 Z*	1000
XC6201P332PR-MS			16 2*	1000
XC6201P362PR-MS			16 5*	1000
XC6201P502PR-MS			16 M*	1000

Notes:\*Representing internal production number.

**PIN DESCRIPTION**

PIN No.		Name	Functions Description
SOT-23-5	SOT-89-3		
2	2	GND	ground
1	3	VIN	input
5	1	VOUT	output
3		NC	No Connect
4		NC	No Connect

**PRODUCT NAMING**

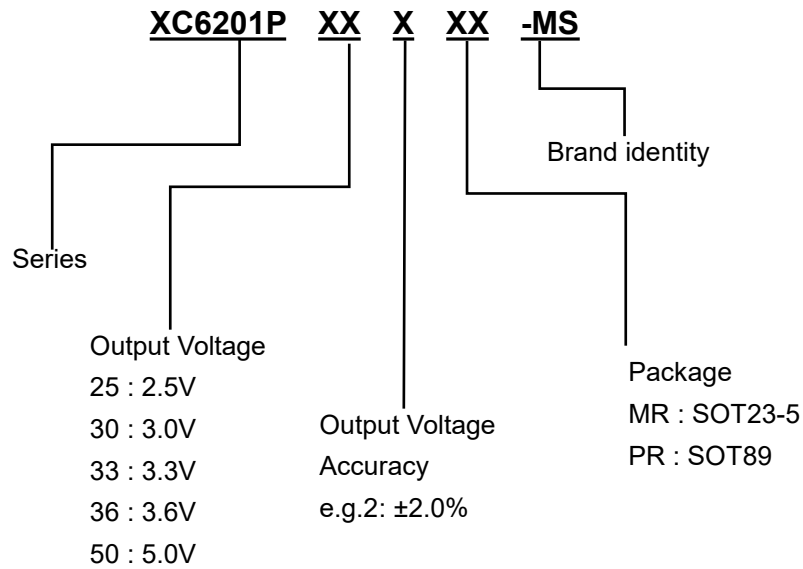

**FUNCTIONAL BLOCK DIAGRAM**

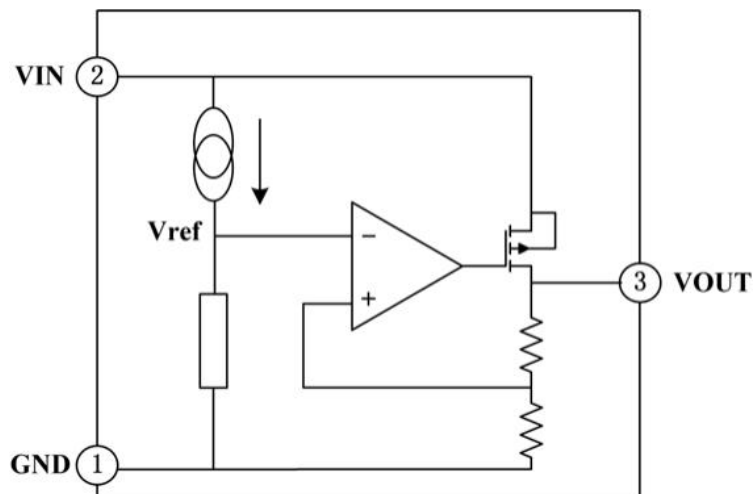

## ABSOLUTEMAXIMUMRATINGS

Description	Symbol	Value range	Unit
Limit Power Voltage	$V_{IN}$	-0.3~+15	V
Storage Temperature Range	$T_{STG}$	-50~+125	°C
Operating Free-air Temperature Range	$T_A$	-40~+85	°C

**Note :** Stresses greater than those listed under “Absolute Maximum Ratings” may cause permanent damage to the device. These are stress ratings only, and functional operation of the device at these or any other conditions beyond those indicated under “Recommended Operating Conditions” is not implied. Exposure to “Absolute Maximum Ratings” for extended periods may affect device reliability.

## HEATDISSIPATION

Description	Symbol	Package	Value range	Unit
Thermal resistance	$\theta_{JA}$	SOT-89-3	200	°C/W
		SOT-23-5L	500	°C/W
Power dissipation	$P_W$	SOT-89-3	500	mW
		SOT-23-5L	200	mW

## DCCHARACTERISTICS(unless otherwise noted $T_A = +25^\circ\text{C}$ )( $V_{IN} = V_{OUT} + 2.0\text{V}$ , $C_{IN} =$

$C_L = 10\mu\text{F}$ ,  $T_a = 25^\circ\text{C}$ , unless otherwise noted)

### Series +2.5V OUTPUT

Parameter	Symbol	Test Condition	Min	Typ	Max	Unit
Output Voltage	$V_{OUT}$	$V_{IN} = V_{OUT} + 2.0\text{V}$ , $I_{OUT} = 10\text{mA}$	2.450	2.500	2.550	V
Output Current	$I_{OUT}$	$V_{IN} = V_{OUT} + 2.0\text{V}$	300	—	—	mA
Load Regulation	$\Delta V_{OUT}$	$V_{IN} = V_{OUT} + 2.0\text{V}$ $1\text{mA} \leq I_{OUT} \leq 300\text{mA}$	—	37	100	mV
Voltage Drop	$V_{DIF}$	$I_{OUT} = 10\text{mA}$ , $\Delta V_{OUT} = 2\%$	—	35	55	mV
Quiescent Current	$I_{SS}$	—	—	2.0	3.0	$\mu\text{A}$
Line Regulation	$\frac{\Delta V_{OUT}}{V_{OUT}} \cdot \Delta V_{IN}$	$V_{OUT} + 1.0\text{V} \leq V_{IN} \leq 12\text{V}$ , $I_{OUT} = 1\text{mA}$	—	—	0.2	%/V
Input Voltage	$V_{IN}$	—	—	—	12	V
Temperature Coefficient	$\frac{\Delta V_{OUT}}{\Delta T_A} \cdot V_{OUT}$	$V_{IN} = V_{OUT} + 2.0\text{V}$ , $I_{OUT} = 10\text{mA}$ , $-40^\circ\text{C} \leq T_A \leq 85^\circ\text{C}$	—	$\pm 100$	—	ppm/ °C
Output Short Circuit Current	$I_{lim}$	$V_{OUT} = 0\text{V}$	—	400	—	

**Note :** When  $V_{IN} = V_{OUT} + 2.0\text{V}$ , as the output voltage declined 2%, the  $V_{DIF} = V_{IN} - V_{OUT}$ .

**Series +3.0V OUTPUT**

Parameter	Symbol	Test Condition	Min	Typ	Max	Unit
Output Voltage	$V_{OUT}$	$V_{IN}=V_{OUT}+2.0V, I_{OUT}=10mA$	2.94	3.0	3.06	V
Output Current	$I_{OUT}$	$V_{IN}=V_{OUT}+2.0V$	300	—	—	mA
Load Regulation	$\Delta V_{OUT}$	$V_{IN}=V_{OUT}+2.0V$ $1mA \leq I_{OUT} \leq 300mA$	—	37	100	mV
Voltage Drop	$V_{DIF}$	$I_{OUT}=100mA, \Delta V_{OUT}=2\%$	—	210	300	mV
Quiescent Current	$I_{SS}$	—	—	2.0	3.0	$\mu A$
Line Regulation	$\frac{\Delta V_{OUT}}{V_{OUT}} * \Delta V_{IN}$	$V_{OUT}+1.0V \leq V_{IN} \leq 12V,$ $I_{OUT}=1mA$	—	—	0.2	%/V
Input Voltage	$V_{IN}$	—	—	—	12	V
Temperature Coefficient	$\frac{\Delta V_{OUT}}{\Delta T_A} * V_{OUT}$	$V_{IN}=V_{OUT}+2.0V, I_{OUT}=10mA,$ $-40^\circ C \leq T_A \leq 85^\circ C$	—	$\pm 100$	—	ppm/ $^\circ C$
Output Short Circuit Current	$I_{lim}$	$V_{OUT}=0V$	—	400	—	mA

**Note :** When  $V_{IN}=V_{OUT}+2.0V$ , as the output voltage declined 2%, the  $V_{DIF}=V_{IN}-V_{OUT}$ .

**Series +3.3V OUTPUT**

Parameter	Symbol	Test Condition	Min	Typ	Max	Unit
Output Voltage	$V_{OUT}$	$V_{IN}=V_{OUT}+2.0V, I_{OUT}=10mA$	2.23	3.3	3.36	V
Output Current	$I_{OUT}$	$V_{IN}=V_{OUT}+2.0V$	300	—	—	mA
Load Regulation	$\Delta V_{OUT}$	$V_{IN}=V_{OUT}+2.0V$ $1mA \leq I_{OUT} \leq 300mA$	—	37	100	mV
Voltage Drop	$V_{DIF}$	$I_{OUT}=100mA, \Delta V_{OUT}=2\%$	—	195	300	mV
Quiescent Current	$I_{SS}$	—	—	2.0	3.0	$\mu A$
Line Regulation	$\frac{\Delta V_{OUT}}{V_{OUT}} * \Delta V_{IN}$	$V_{OUT}+1.0V \leq V_{IN} \leq 12V,$ $I_{OUT}=1mA$	—	—	0.2	%/V
Input Voltage	$V_{IN}$	—	—	—	12	V
Temperature Coefficient	$\frac{\Delta V_{OUT}}{\Delta T_A} * V_{OUT}$	$V_{IN}=V_{OUT}+2.0V, I_{OUT}=10mA,$ $-40^\circ C \leq T_A \leq 85^\circ C$	—	$\pm 100$	—	ppm/ $^\circ C$
Output Short Circuit Current	$I_{lim}$	$V_{OUT}=0V$	—	400	—	mA

**Note :** When  $V_{IN}=V_{OUT}+2.0V$ , as the output voltage declined 2%, the  $V_{DIF}=V_{IN}-V_{OUT}$ .

**Series +3.6V OUTPUT**

Parameter	Symbol	Test Condition	Min	Typ	Max	Unit
Output Voltage	$V_{OUT}$	$V_{IN}=V_{OUT}+2.0V, I_{OUT}=10mA$	3.52	3.6	3.67	V
Output Current	$I_{OUT}$	$V_{IN}=V_{OUT}+2.0V$	300	—	—	mA
Load Regulation	$\Delta V_{OUT}$	$V_{IN}=V_{OUT}+2.0V$ $1mA \leq I_{OUT} \leq 300mA$	—	37	100	mV
Voltage Drop	$V_{DIF}$	$I_{OUT}=100mA, \Delta V_{OUT}=2\%$	—	180	300	mV
Quiescent Current	$I_{SS}$	—	—	2.0	3.0	$\mu A$
Line Regulation	$\frac{\Delta V_{OUT}}{V_{OUT}} \cdot \Delta V_{IN}$	$V_{OUT}+1.0V \leq V_{IN} \leq 12V,$ $I_{OUT}=1mA$	—	—	0.2	%/V
Input Voltage	$V_{IN}$	—	—	—	12	V
Temperature Coefficient	$\frac{\Delta V_{OUT}}{\Delta T_A} \cdot V_{OUT}$	$V_{IN}=V_{OUT}+2.0V, I_{OUT}=10mA,$ $-40^\circ C \leq T_A \leq 85^\circ C$	—	$\pm 100$	—	ppm/ $^\circ C$
Output Short Circuit Current	$I_{lim}$	$V_{OUT}=0V$	—	400	—	

**Note :** When  $V_{IN}=V_{OUT}+2.0V$ , as the output voltage declined 2%, the  $V_{DIF}=V_{IN}-V_{OUT}$ .

**Series +5.0V OUTPUT**

Parameter	Symbol	Test Condition	Min	Typ	Max	Unit
Output Voltage	$V_{OUT}$	$V_{IN}=V_{OUT}+2.0V, I_{OUT}=10mA$	4.9	5.0	5.1	V
Output Current	$I_{OUT}$	$V_{IN}=V_{OUT}+2.0V$	300	—	—	mA
Load Regulation	$\Delta V_{OUT}$	$V_{IN}=V_{OUT}+2.0V$ $1mA \leq I_{OUT} \leq 300mA$	—	37	100	mV
Voltage Drop	$V_{DIF}$	$I_{OUT}=100mA, \Delta V_{OUT}=2\%$	—	170	300	mV
Quiescent Current	$I_{SS}$	—	—	2.0	3.0	$\mu A$
Line Regulation	$\frac{\Delta V_{OUT}}{V_{OUT}} \cdot \Delta V_{IN}$	$V_{OUT}+1.0V \leq V_{IN} \leq 12V,$ $I_{OUT}=1mA$	—	—	0.2	%/V
Input Voltage	$V_{IN}$	—	—	—	12	V
Temperature Coefficient	$\frac{\Delta V_{OUT}}{\Delta T_A} \cdot V_{OUT}$	$V_{IN}=V_{OUT}+2.0V, I_{OUT}=10mA,$ $-40^\circ C \leq T_A \leq 85^\circ C$	—	$\pm 100$	—	ppm/ $^\circ C$
Output Short Circuit Current	$I_{lim}$	$V_{OUT}=0V$	—	400	—	mA

**Note :** When  $V_{IN}=V_{OUT}+2.0V$ , as the output voltage declined 2%, the  $V_{DIF}=V_{IN}-V_{OUT}$ .

## FUNCTIONALDESCRIPTION

XC6201PXXXX-MS series are linear voltage regulator ICs withstanding 12V voltage. The series IC consists of a voltage reference, an error amplifier, a current limiter and a phase compensation circuit plus a driver transistor. The output stabilization capacitor is also compatible with low ESR ceramic capacitors.

The over current protection circuit and the over voltage protection circuit are built-in. The protection circuit will operate when the output current or input voltage reaches limit level.

## TYPICALAPPLICATIONCIRCUIT

Basic Circuit

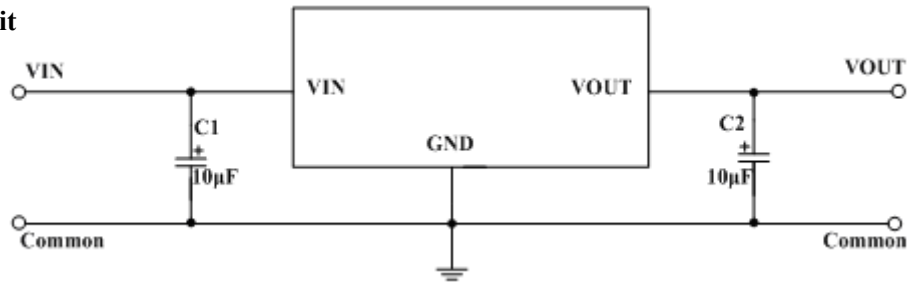

**SOT-23-5L Package Outline Dimensions**

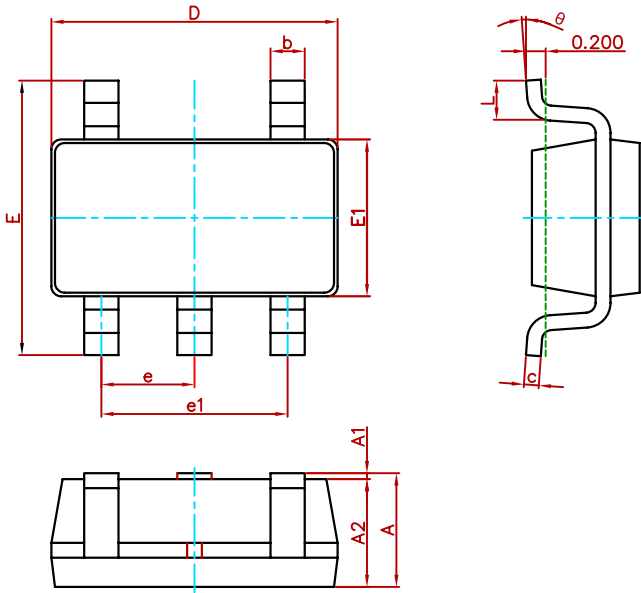

Symbol	Dimensions In Millimeters		Dimensions In Inches	
	Min.	Max.	Min.	Max.
A	1.050	1.250	0.041	0.049
A1	0.000	0.100	0.000	0.004
A2	1.050	1.150	0.041	0.045
b	0.300	0.500	0.012	0.020
c	0.100	0.200	0.004	0.008
D	2.820	3.020	0.111	0.119
E	2.650	2.950	0.104	0.116
E1	1.500	1.700	0.059	0.067
e	0.950(BSC)		0.037(BSC)	
e1	1.800	2.000	0.071	0.079
L	0.300	0.600	0.012	0.024
θ	0°	8°	0°	8°

**SOT-23-5L Suggested Pad Layout**

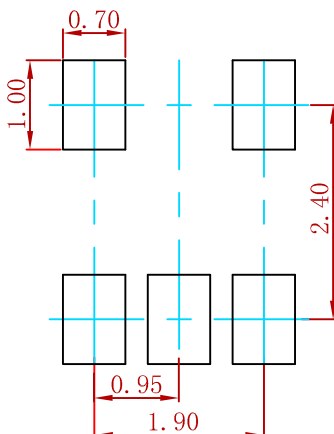

Note:  
 1. Controlling dimension: in millimeters.  
 2. General tolerance:  $\pm 0.05$ mm.  
 3. The pad layout is for reference purposes only.



**SOT-89-3 PACKAGE MECHANICAL DATA**

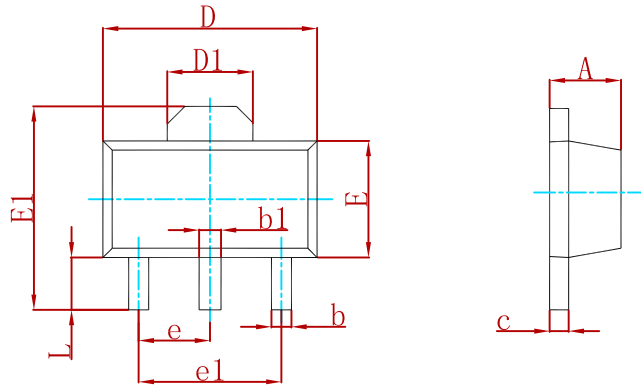

Symbol	Dimensions In Millimeters		Dimensions In Inches	
	Min	Max	Min	Max
A	1.400	1.600	0.055	0.063
b	0.320	0.520	0.013	0.020
b1	0.400	0.580	0.016	0.023
c	0.350	0.440	0.014	0.017
D	4.400	4.600	0.173	0.181
D1	1.550 REF.		0.061 REF.	
E	2.300	2.600	0.091	0.102
E1	3.940	4.250	0.155	0.167
e	1.500 TYP.		0.060 TYP.	
e1	3.000 TYP.		0.118 TYP.	
L	0.900	1.200	0.035	0.047

**SOT-89-3 Suggested Pad Layout**

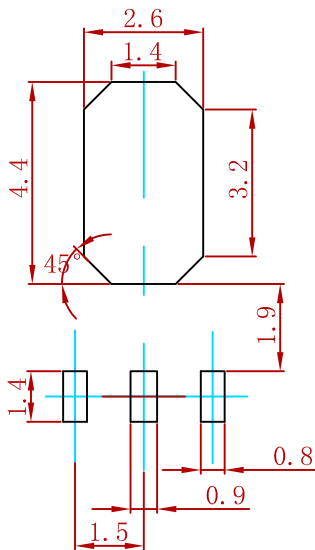

Note:  
 1. Controlling dimension: in millimeters.  
 2. General tolerance:  $\pm 0.05$  mm.  
 3. The pad layout is for reference purposes only.

## Attention

- Any and all MSKSEMI Semiconductor products described or contained herein do not have specifications that can handle applications that require extremely high levels of reliability, such as life-support systems, aircraft's control systems, or other applications whose failure can be reasonably expected to result in serious physical and/or material damage. Consult with your MSKSEMI Semiconductor representative nearest you before using any MSKSEMI Semiconductor products described or contained herein in such applications.
- MSKSEMI Semiconductor assumes no responsibility for equipment failures that result from using products at values that exceed, even momentarily, rated values (such as maximum ratings, operating condition ranges, or other parameters) listed in products specifications of any and all MSKSEMI Semiconductor products described or contained herein.
- Specifications of any and all MSKSEMI Semiconductor products described or contained herein stipulate the performance, characteristics, and functions of the described products in the independent state, and are not guarantees of the performance, characteristics, and functions of the described products as mounted in the customer's products or equipment. To verify symptoms and states that cannot be evaluated in an independent device, the customer should always evaluate and test devices mounted in the customer's products or equipment.
- MSKSEMI Semiconductor strives to supply high-quality high-reliability products. However, any and all semiconductor products fail with some probability. It is possible that these probabilistic failures could give rise to accidents or events that could endanger human lives, that could give rise to smoke or fire, or that could cause damage to other property. When designing equipment, adopt safety measures so that these kinds of accidents or events cannot occur. Such measures include but are not limited to protective circuits and error prevention circuits for safe design, redundant design, and structural design.
- In the event that any or all MSKSEMI Semiconductor products (including technical data, services) described or contained herein are controlled under any of applicable local export control laws and regulations, such products must not be exported without obtaining the export license from the authorities concerned in accordance with the above law.
- No part of this publication may be reproduced or transmitted in any form or by any means, electronic or mechanical, including photocopying and recording, or any information storage or retrieval system, or otherwise, without the prior written permission of MSKSEMI Semiconductor.
- Information (including circuit diagrams and circuit parameters) herein is for example only ; it is not guaranteed for volume production. MSKSEMI Semiconductor believes information herein is accurate and reliable, but no guarantees are made or implied regarding its use or any infringements of intellectual property rights or other rights of third parties.
- Any and all information described or contained herein are subject to change without notice due to product/technology improvement, etc. When designing equipment, refer to the "Delivery Specification" for the MSKSEMI Semiconductor product that you intend to use.

## X-ON Electronics

Largest Supplier of Electrical and Electronic Components

*Click to view similar products for [Linear Voltage Regulators](#) category:*

*Click to view products by [MSKSEMI](#) manufacturer:*

Other Similar products are found below :

[LV5684PVD-XH](#) [MCDTSA6-2R](#) [L7815ACV-DG](#) [714954EB](#) [ZMR500QFTA](#) [BA033LBSG2-TR](#) [LV5680P-E](#) [L79M05T-E](#) [L78LR05D-MA-E](#) [NCV317MBTG](#) [NTE7227](#) [MP2018GZD-33-P](#) [MP2018GZD-5-P](#) [LV5680NPVC-XH](#) [LT1054CN8](#) [UA78L09CLP](#) [UA78L09CLPR](#) [CAT6221-PPTD-GT3](#) [MC78M09CDTRK](#) [NCV51190MNTAG](#) [78M05](#) [HT7150-1](#) [UM1540DB-18](#) [XC6234H281VR-G](#) [WL2834CA-6/TR](#) [TPL730F33-5TR](#) [TLS850F1TA](#) [V50](#) [TPS549B22RVFR](#) [UM1540DB-33](#) [WL9200P3-50B](#) [WL9100P3-33B](#) [WL9005D4-33](#) [XC6219B152MR](#) [WL2855K33-3/TR](#) [PJ54BM33SE](#) [PJ9500M25SA](#) [MD7218E33PC1](#) [H7533-2PR](#) [SK7812AU](#) [SD1A30](#) [78L33](#) [TP78L33T3](#) [L78L33ACUTR](#) [SK6513ST3A-50](#) [SK6054D4-09](#) [SK6054D4-18](#) [SK6054D4-11](#) [SK6054D4-10](#) [LM79L12F](#) [HLP2985AIM5X-5.0](#)