

Fan Vibration Absorber

For Fans from 40mm to 119mm

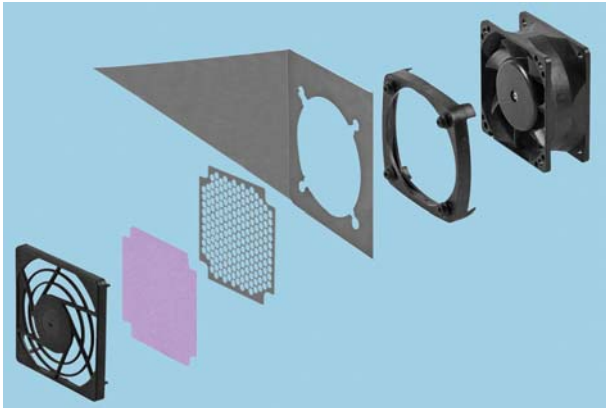

Features:

- Easy to attach axial fans with patented fastening elements.
- No tools or screws are required.
- Fan vibration absorbers greatly reduce the transmission of vibrations to the panel.
- Housing causing a reduction in the level of noise up to 9 decibels.
- Fan vibrations are absorbed by the flexible sleeves, thereby reducing damage and increasing the life span of the fan.
- Product accessories include screwless, mountable plastic finger guards, filter media, EMI shields, filter guards and rivets.
- The fan vibration sleeves and accessories will fit most fan manufacturer's products.

Fan Vibration Sleeves

Material : TPE (thermoplastic elastomer) RoHS compliant.
Color : Black.
Hardness : ca 70° Shore A.

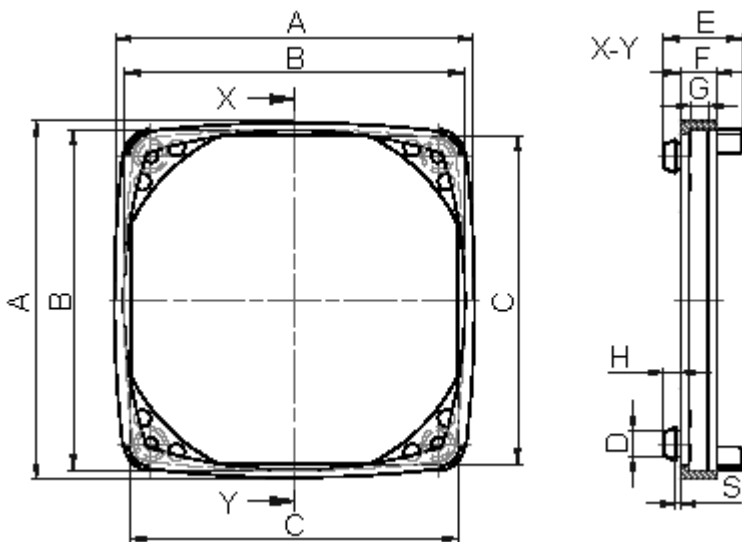

Fan Vibration Absorber

For Fans from 40mm to 119mm



Specifications

Description	A	B	C	D	E	F	G	H	S	Panel Thickness	Part Number
Fan Sleeve, 40mm	1.692 (43)	11.574 (40)	1.496 (38)	0.177 (4.5)	0.581 (14.75)	0.207 (5.25)	0.008 (2.0)	0.138 (3.5)	0.039 (1.0)	0.0030 (0.75) to 0.049 (1.25)	MC-QLM-40-20-10
Fan Sleeve, 60mm	2.520 (64)	2.362 (60)	2.283 (58)	0.197 (5.0)	0.689 (17.5)	0.295 (7.5)	0.012 (2.0)	0.157 (4.0)			MC-QLM-60-30-10
Fan Sleeve, 80mm	3.307 (84)	3.150 (80)	3.031 (77)	0.228 (5.8)	0.728 (18.5)	0.335 (8.5)	0.016 (4.0)				MC-QLM-80-40-10
Fan Sleeve, 92mm	3.819 (97)	3.622 (92)	3.504 (89)	0.236 (6.0)	0.768 (19.5)	0.374 (9.5)		MC-QLM-92-40-10			
Fan Sleeve, 119mm	4.921 (125)	4.685 (119)	4.567 (116)	0.315 (8.0)	0.945 (24.0)	0.413 (10.5)	0.020 (5.0)	0.177 (4.5)			MC-QLM-119-50-10

Dimensions: Inches (Millimetres)

Part Number Explanation

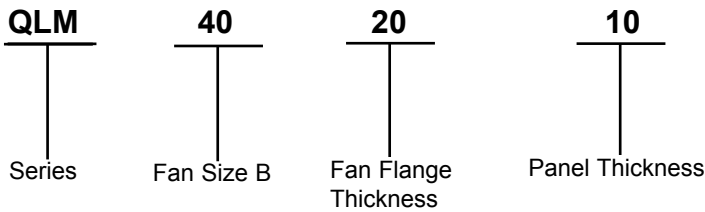

Panel Thickness : 10 = Panel thickness from 0.75 to 1.25mm.



Fan Vibration Absorber

For Fans from 40mm to 119mm



Plastic Fan Guards

Material : Plastic.
 Color : Black.
 Equal Guideline : 2002/95/EG (RoHS compliant).

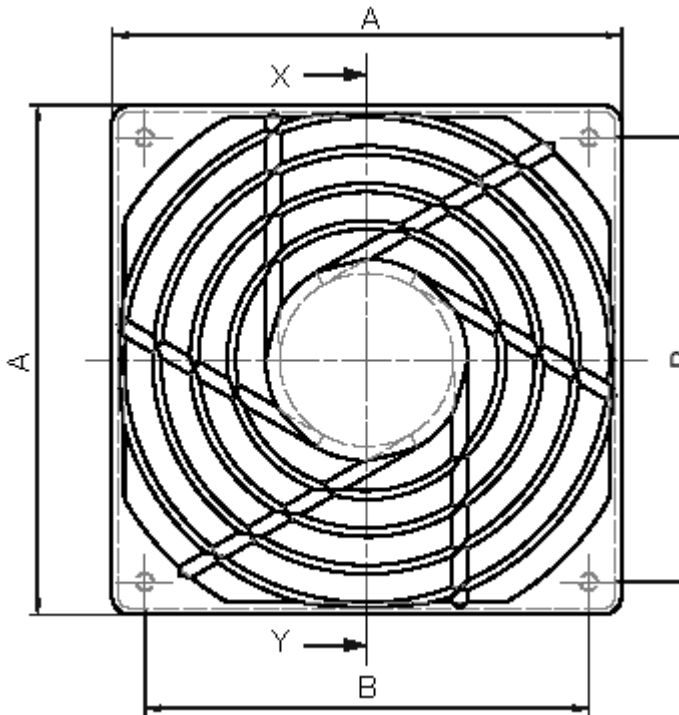

Specifications

Description	A	B	C	D	E	F	G	Part Number
Finger Guard, 92mm	3.976 (101.0)	3.248 (82.5)	3.622 (92.0)	1.181 (30.0)	0.594 (15.1)	0.335 (8.5)	0.098 (2.5)	MC-QSG-92-02
Finger Guard, 119mm	5.039 (128.0)	4.133 (105.0)	4.685 (119.0)	1.654 (42.0)	0.654 (16.6)	0.354 (9.0)	0.118 (3.0)	MC-QSG-119-02

Dimensions: Inches (Millimetres)

Part Number Explanation

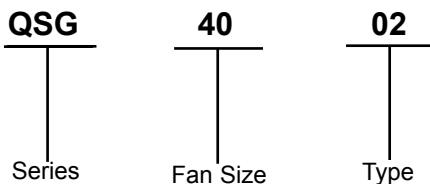

Type : 02 = See dimension "A". Panel hole layout hidden
 Only available in 92mm and 119mm sizes.



Fan Vibration Absorber

For Fans from 40mm to 119mm



EMI Filter Shields

Material : High-grade steel (spring V2a)/material No. 1.4310.
 Material Thickness: : 0.2mm to 0.3mm.

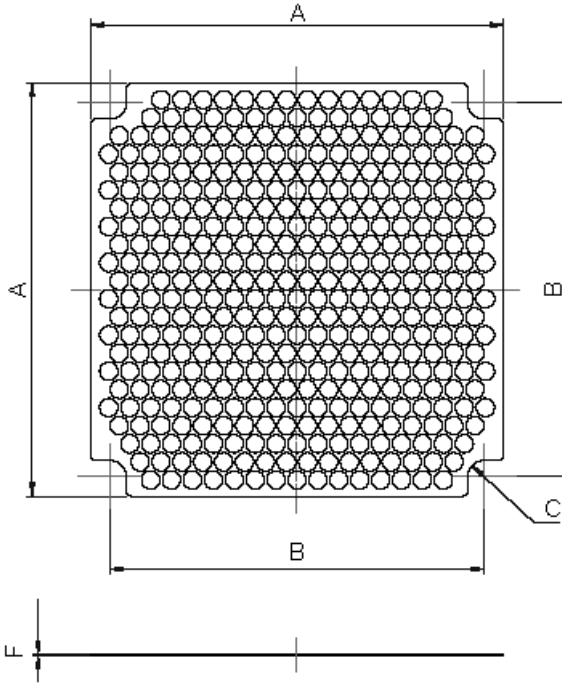

Specifications

Description	A	B	C	D	E	F	Part Number
EMI Shield, 40mm	1.654 (42.0)	1.260 (32.0)	R 0.094 (2.4)	0.098 (2.5)	0.118 (3.0)	0.008 (0.2)	MC-QSB-40-01
EMI Shield, 60mm	2.441 (62.0)	1.969 (50.0)	R 0.106 (2.7)	0.138 (3.5)	0.157 (4.0)		MC-QSB-60-01
EMI Shield, 80mm	3.228 (82.0)	2.815 (71.5)	R 0.126 (3.2)	0.157 (4.0)	0.177 (4.5)		MC-QSB-80-01
EMI Shield, 92mm	3.700 (94.0)	3.248 (82.5)			0.217 (5.5)		MC-QSB-92-01
EMI Shield, 119mm	4.764 (121.0)	4.133 (105.0)	R 0.165 (4.2)			0.012 (0.3)	MC-QSB-119-01

Dimensions: Inches (Millimeters)

Part Number Explanation

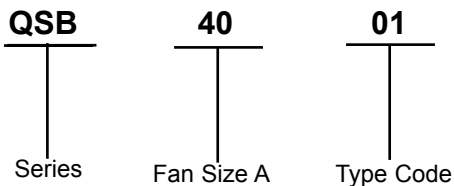

Fan Vibration Absorber

For Fans from 40mm to 119mm



Filter Media

Material : Foam dust filter FL100.
 Filter Class : G2 DIN EN 779.
 Material Thickness : ca. 5mm.

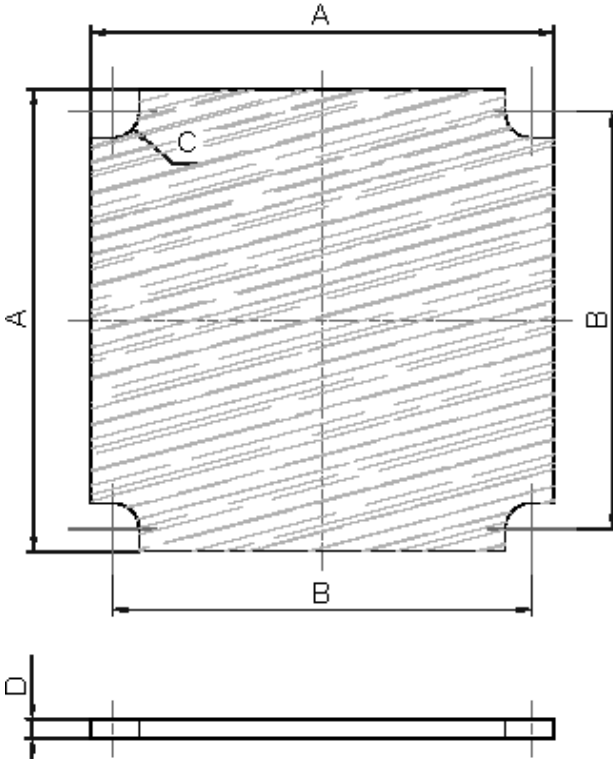

Specifications

Description	A	B	C	D	Part Number
Fan Filter, 40mm	1.575 (40.0)	1.260 (32.0)	R 0.118 (3.0)	0.197 (5.0)	MC-QF-40-01
Fan Filter, 60mm	2.362 (60.0)	1.969 (50.0)	R 0.138 (3.5)		MC-QF-60-01
Fan Filter, 80mm	3.150 (80.0)	2.815 (71.5)	R 0.157 (4.0)		MC-QF-80-01
Fan Filter, 92mm	3.622 (92.0)	3.248 (82.5)	R 0.177 (4.5)		MC-QF-92-01
Fan Filter, 119mm	4.685 (119.0)	4.133 (105.0)	R 0.217 (5.5)		MC-QF-119-01

Dimensions: Inches (Millimeteres)

Part Number Explanation

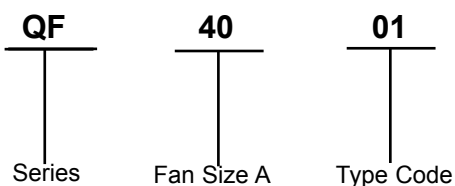

Fan Vibration Absorber

For Fans from 40mm to 119mm



Rivets

Material : Plastic.
Color : Black.
Equal Guideline : 2002/95/EG (RoHS compliant).

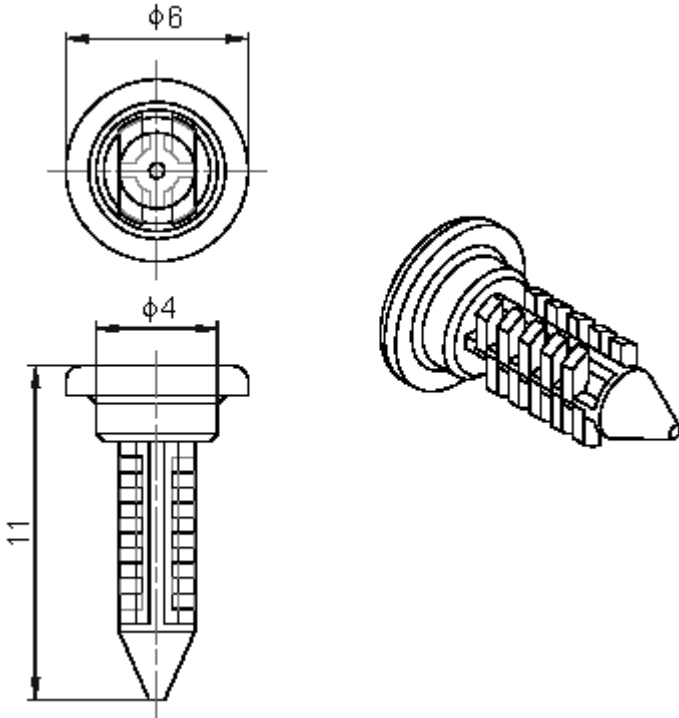

Specifications

Description	Part Number
Fan Fasteners, Rubber PK10	MC-QF-40-01



X-ON Electronics

Largest Supplier of Electrical and Electronic Components

Click to view similar products for [Multicomp](#) manufacturer:

Other Similar products are found below :

[001-0001](#) [001-0003](#) [001-0006](#) [001-0014](#) [001-0017](#) [001-0020](#) [001-0021](#) [001-0023](#) [001-0028](#) [001-0029](#) [001-0030](#) [001-0031](#) [001-0035](#) [001-0037](#) [001-0041](#) [001-0076](#) [003-0001](#) [003-0002](#) [003-0003](#) [003-0011](#) [003-0012](#) [003-0013](#) [003-0015](#) [003-0039](#) [004-0012F](#) [004-0013F](#) [004-0014F](#) [004-0015F](#) [004-0016F](#) [004-0017F](#) [004-0018F](#) [006-0001F](#) [006-0012F](#) [006-0013F](#) [006-0045](#) [010-0001](#) [010-0001F](#) [010-0005](#) [010-0005F](#) [010-0011](#) [010-0014](#) [010-0024](#) [010-0024F](#) [010-0029](#) [010-0041](#) [010-0041F](#) [010-0042F3](#) [010-0055](#) [010-0055F](#) [010-0060](#)