

Heavy Duty Disc - Type EMIFIL® (Three-terminal capacitor)

DSN9H series **Reference Specification**

1.Scope

This reference specification applies to Heavy Duty Disc-Type EMIFIL®(Three-terminal capacitor).

2.Part Numbering

(Ex.)

DS	N	9	H	B3	2E	271	Q93	A
①	②	③	④	⑤	⑥	⑦	⑧	⑨

- ① Product ID (Disc-Type EMIFIL®)
- ② Structure N : No Ferrite Beads Type
- ③ Style
- ④ Features
- ⑤ Temperature Characteristics
- ⑥ Rated Voltage
- ⑦ Capacitance

□□□
↓
Marked three digits system.(Ex. 270pF→271)

⑧ Lead Type
Q5□ : Bulk (in mm)

	Long Lead Type
Straight Lead Type	Q55
Lead Length(l)	25.0 min.

Lead Length (l) : See item 9.

Q9□ : Taping (in mm)

Straight Lead Type	Q91	Q92	Q93
Dimension H	20.0±1.0	16.5±1.0	18.5±1.0

Dimension H : See item 9.

⑨ Packaging Code A: Ammo Pack / B: Bulk

3.Rating

- Operating temperature : -40 to +105°C
- Storage Temperature : -55 to +105°C
- Insulation Resistance : 10000MΩ min.
- Rated Current : 6A(DC)
- Equivalent Circuit :

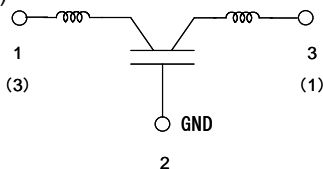

Others : See Table 1

Table 1

Customer Part Number	Murata Part Number	Temperature Characteristics		Capacitance	Rated Voltage	Withstanding Voltage	Unit Mass (Typical value)
		-25~+85°C	-40~+105°C				
	DSN9HB32E220Q55B	±10%	±20%	22pF ± 20%	250V (DC)	625V(DC)	0.59g
	DSN9HB32E220Q91A						
	DSN9HB32E220Q92A						
	DSN9HB32E220Q93A						
	DSN9HB32E101Q55B						
	DSN9HB32E101Q91A						
	DSN9HB32E101Q92A						
	DSN9HB32E101Q93A						
	DSN9HB32E271Q55B						
	DSN9HB32E271Q91A						
	DSN9HB32E271Q92A						
	DSN9HB32E271Q93A						
	DSN9HB32E222Q55B	±30%	±20%	2200pF ± 20%			0.58g
	DSN9HB32E222Q91A						
	DSN9HB32E222Q92A						
	DSN9HB32E222Q93A						

4. Testing Conditions

<Unless otherwise specified>

Temperature : Ordinary Temperature 15 to 35°C
 Humidity : Ordinary Humidity 25 to 85 %(RH)

<In case of doubt>

Temperature : 20 ± 2°C
 Humidity : 60 to 70 %(RH)
 Atmospheric Pressure : 86 to 106 kPa

5. Style and Dimension

See item 9.

6. Marking

Characteristics	Marked letter code : B (Temperature Characteristics Number: B3)
Capacitance	Marked real number. (22pF) Ex. 22pF→22 Marked three digits system. (100pF to 2200pF) Ex. 2200pF→222
Capacitance Tolerance	Marked letter code. M (±20%)
Rated Voltage	Marked voltage value. (250V)
Trade Mark	Marked as 

7. Performance

No.	Item	Specification	Test Method																								
7.1	Appearance and Dimensions	Meet item 9.	Visual Inspection and measured with Slide Calipers.																								
7.2	Marking	Marking is able to be read easily.	Visual Inspection.																								
7.3	Capacitance and Tolerance	Meet item 3.	Table 2 <table border="1"> <thead> <tr> <th>Frequency</th> <th>Test Voltage</th> <th>Capacitance</th> </tr> </thead> <tbody> <tr> <td>1±0.1MHz</td> <td rowspan="2">1±0.2V(rms)</td> <td>22pF~270pF</td> </tr> <tr> <td>1±0.1kHz</td> <td>2200pF</td> </tr> </tbody> </table>	Frequency	Test Voltage	Capacitance	1±0.1MHz	1±0.2V(rms)	22pF~270pF	1±0.1kHz	2200pF																
Frequency	Test Voltage	Capacitance																									
1±0.1MHz	1±0.2V(rms)	22pF~270pF																									
1±0.1kHz		2200pF																									
7.4	Insulation Resistance(I.R.)	Meet item 3.	Test Voltage : Rated Voltage Time : 1 minute.																								
7.5	Withstanding Voltage	Products shall not be damaged.	Test Voltage : 2.5 times for Rated Voltage Time : 1 to 5 seconds Charge Current : 10 mA max.																								
7.6	Temperature Characteristics	Meet item 3.	Capacitance shall be measured at each step specified in Table 3 after reaching the thermal equilibrium. The capacitance change against the capacitance at step 3 shall be calculated. Table3 -25 to 85°C <table border="1"> <thead> <tr> <th>Step</th> <th>1</th> <th>2</th> <th>3</th> <th>4</th> <th>5</th> </tr> </thead> <tbody> <tr> <td>Temp. (°C)</td> <td>+20±2</td> <td>-25±2</td> <td>+20±2</td> <td>+85±2</td> <td>+20±2</td> </tr> </tbody> </table> -40 to 105°C <table border="1"> <thead> <tr> <th>Step</th> <th>1</th> <th>2</th> <th>3</th> <th>4</th> <th>5</th> </tr> </thead> <tbody> <tr> <td>Temp. (°C)</td> <td>+20±2</td> <td>-40±2</td> <td>+20±2</td> <td>+105±2</td> <td>+20±2</td> </tr> </tbody> </table>	Step	1	2	3	4	5	Temp. (°C)	+20±2	-25±2	+20±2	+85±2	+20±2	Step	1	2	3	4	5	Temp. (°C)	+20±2	-40±2	+20±2	+105±2	+20±2
Step	1	2	3	4	5																						
Temp. (°C)	+20±2	-25±2	+20±2	+85±2	+20±2																						
Step	1	2	3	4	5																						
Temp. (°C)	+20±2	-40±2	+20±2	+105±2	+20±2																						
7.7	Solderability	Along the circumference of terminal shall be covered with new solder at least 75%.	Flux : Ethanol solution of rosin,25(wt)% (dipped for 5 to 10 seconds) Pre-heat : 150±10°C, 60~90 s Solder : Sn-3.0Ag-0.5Cu Solder Temperature : 245±5°C Immersion Time : 2 ± 0.5 seconds Immersion Depth : 2 to 2.5 mm from the bottom of the body.																								

No.	Item	Specification	Test Method						
7.8	Resistance to Soldering Heat	Meet Table 4. Table 4 <table border="1"> <tr> <td>Appearance</td> <td>No damaged.</td> </tr> <tr> <td>Capacitance Change</td> <td>within ± 5%</td> </tr> <tr> <td>Withstanding Voltage</td> <td>No damaged.</td> </tr> </table>	Appearance	No damaged.	Capacitance Change	within ± 5%	Withstanding Voltage	No damaged.	Flux : Ethanol solution of rosin,25(wt)% (dipped for 5 to 10 seconds) Pre-heat : 150±10°C, 60~90 s Solder : Sn-3.0Ag-0.5Cu Solder Temperature : 270 ± 5 °C Immersion Time : 3± 0.5 seconds Immersion Depth : 1.6 ± 0.8 mm from the bottom of the body. Then measured after exposure in the room Condition for 4 to 24hours.
Appearance	No damaged.								
Capacitance Change	within ± 5%								
Withstanding Voltage	No damaged.								
7.9	Humidity	Meet Table 5. Table 5 <table border="1"> <tr> <td>Appearance</td> <td>No damaged.</td> </tr> <tr> <td>Capacitance Change</td> <td>within ± 10%</td> </tr> </table>	Appearance	No damaged.	Capacitance Change	within ± 10%	Temperature : 40 ± 2°C Humidity : 90 to 95 %(RH) Time : 1000 hours(+48-0 hours) Then measured after exposure in the room condition for 20 to 24hours.		
Appearance	No damaged.								
Capacitance Change	within ± 10%								
7.10	Humidity Life	<table border="1"> <tr> <td>Insulation Resistance</td> <td>1000MΩ min.</td> </tr> </table>	Insulation Resistance	1000MΩ min.	Temperature : 40 ± 2°C Humidity : 90 to 95 %(RH) Time : 1000 hours(+48-0 hours) Charge Voltage : Rated Voltage Then measured after exposure in the room condition for 20 to 24hours.				
Insulation Resistance	1000MΩ min.								
7.11	Heat Life	Meet Table 6. Table 6 <table border="1"> <tr> <td>Appearance</td> <td>No evidence of mechanical damage. (It may become dark.)</td> </tr> <tr> <td>Capacitance Change</td> <td>within ± 10%</td> </tr> <tr> <td>Insulation Resistance</td> <td>1000MΩ min.</td> </tr> </table>	Appearance	No evidence of mechanical damage. (It may become dark.)	Capacitance Change	within ± 10%	Insulation Resistance	1000MΩ min.	Temperature : 105 ± 3°C Time : 1000 hours(+48-0 hours) Applying Voltage : 2 times of DC rated voltage Charge Current : 10 mA max. Then measured after exposure in the room condition for 4 to 24hours.
Appearance	No evidence of mechanical damage. (It may become dark.)								
Capacitance Change	within ± 10%								
Insulation Resistance	1000MΩ min.								
7.12	Cold Resistance	Meet Table 7. Table 7 <table border="1"> <tr> <td>Appearance</td> <td>No damaged.</td> </tr> <tr> <td>Capacitance Change</td> <td>within ± 10%</td> </tr> <tr> <td>Insulation Resistance</td> <td>10000MΩ min.</td> </tr> </table>	Appearance	No damaged.	Capacitance Change	within ± 10%	Insulation Resistance	10000MΩ min.	Temperature : -55 ± 2°C Time : 1000 hours(+48-0 hours) Then measured after exposure in the room condition for 4 to 24hours.
Appearance	No damaged.								
Capacitance Change	within ± 10%								
Insulation Resistance	10000MΩ min.								
7.13	Temperature Cycling	Meet Table 5.	Step1 -55°C(+0°C,-3°C) / 30 min. Step2 Ordinary Temp. / within 5 min. Step3 +105°C(+3°C,-0°C) / 30 min. Step4 Ordinary Temp. / within 5 min. Total 100 cycle. Then measured after exposure in the room condition for 4 to 24 hours.						

8.Mounting Hole

Bulk

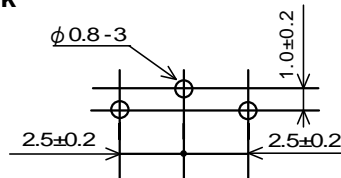

Taping

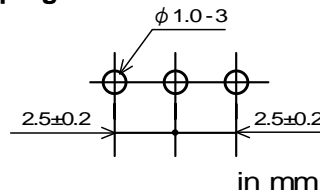

9.Style and Dimension

(1) Bulk

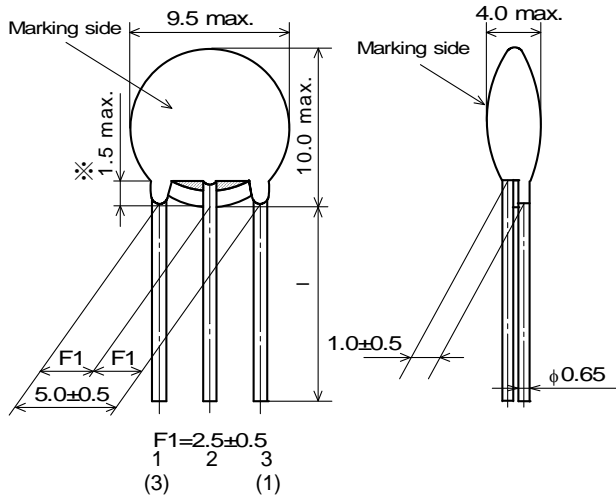

* Coating extending on leads does not exceed the tangent line.
Exposed electrodes are covered with solder.

Lead Type	I
Q55	25.0 min.

(in mm)

(2) Taping

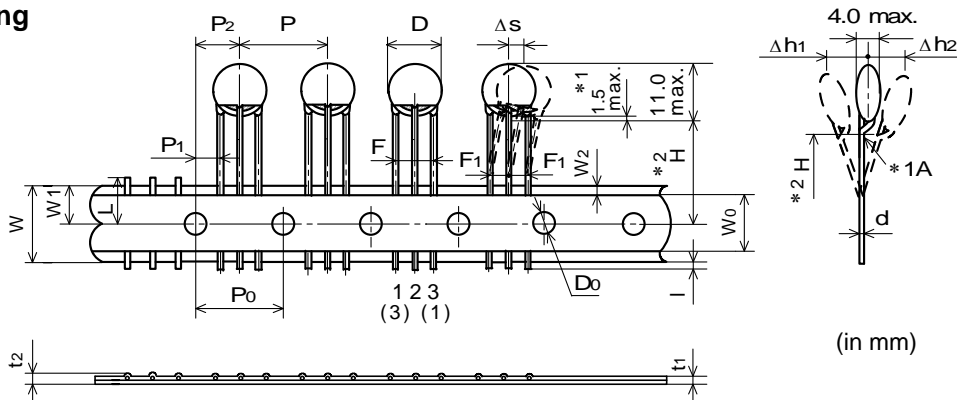

*1.Coating extending on leads does not exceed the start of bend.(Point A)
Exposed electrodes are covered with solder.

*2.H : to be measured from the forming Point A.

Table 7

Code	Description	Dimensions		Remark
P	Pitch of Component	12.7		Product Inclination ΔS Determines Crossing
P0	Pitch of Sprocket Hole	12.7±0.2		
P1	Length from Hole Center to Lead	3.85±0.7		
P2	Length from Hole Center to Component Center	6.35±1.3		Shift In Tape In Direction of Feed
D	Width of Body	9.5 max.		
ΔS	Deviation along tape,Left or Right	0±1.0		
W	Carrier Tape Width	18.0±0.5		
W1	Position of Sprocket Hole	9.0+0 / -0.5		Tape Widthwise Shift
l	Protrusion Length	+0.5 ~ -1.0		
D0	Diameter of Sprocket Hole	φ 4.0±0.1		
d	Lead Diameter	φ 0.6		
t1	Total Tape Thickness	0.7±0.2		Includes Thickness of Bonding Tape
t2	Total Thickness,Tape and Lead Wire	1.5 max.		
Δh1	Deviation across Tape,front	1.0 max.		
Δh2	Deviation across Tape,rear	1.0 max.		
L	Portion to Cut in Case of Defect	11.0+0 / -1.0		
W0	Hold Down Tape Width	12.0±0.5		
W2	Hold Down Tape Position	1.5±1.5		
H	Lead length between sprocket hole and forming position	Q91	20.0±1.0	
		Q92	16.5±1.0	
		Q93	18.5±1.0	
F	Lead Spacing	5.0+0.8 / -0.2		
F1		2.5+0.4 / -0.2		

(in mm)

10. Taping

10.1 Supplement condition of taping

- (1) A maximum of 0.3% of the components quantity per ammo pack may be missing without consecutive missing components.
- (2) The adhesive power of the tape shall have over 2.94N at the following condition.

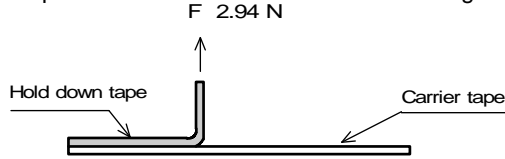

(3) Splicing method of tape

1. Carrier tape

Carrier tape shall be spliced by cellophane tape.
Overall thickness shall be less than 1.05 mm.

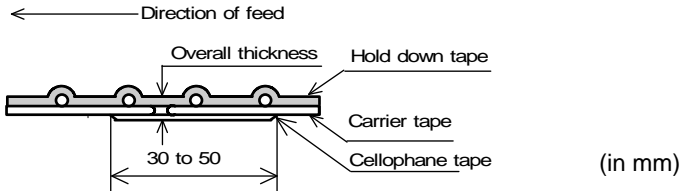

2. Hold down tape

Hold down tape shall be spliced with overlapping.
Overall thickness shall be less than 1.05 mm.

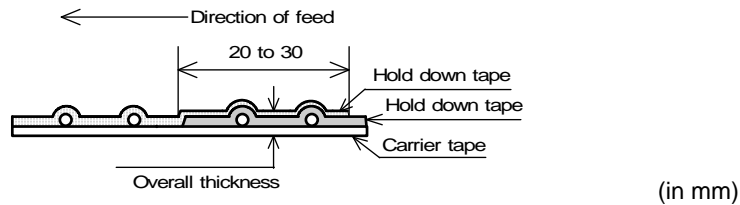

3. Both carrier tape and hold down tape

Both tapes shall be cut zigzag and spliced with splicing tape.

11. Packing

11.1 Packing quantity

The standard packing quantity is as follows.

(The packing quantity may be changed due to a fraction of order.)

Minimum Packing Form and Quantity

Terminal Configuration		A Unit Quantity Bulk : in a plastic bag Taping : in an Ammo pack	* Standard Quantity in a container (corrugated cardboard box)
Bulk	Long Lead Type (Q55)	250 pcs.	5000 pcs.
Taping (Q9□)		2000 pcs.	20000 pcs.

* A quantity in a container is depending on a quantity of an order.

11.2 Packing Form

(1) Bulk

<A plastic bag pack>

1. Products are packed into a plastic bag.

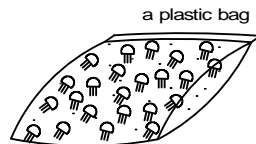

2. The plastic bags are put into a container (corrugated cardboard box) depending on a quantity of an order.

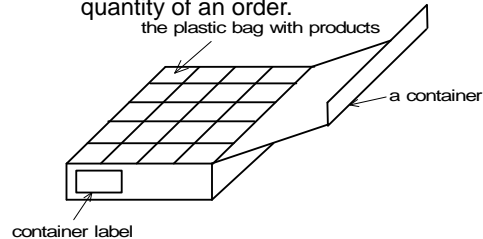

(2) Taping

<An Ammo pack >

1. Folding the tape per 25 pitches, products are packed into an ammo package so that each product of each layer wound zigzag is put on top of one another. [Fig.1]
2. The dimensions of the ammo package are indicated in [Fig 2].
3. The ammo packages are put into a container (corrugated cardboard box) depending on a quantity of an order.
4. Not less than 3 consecutive of component shall be missing on both edge of tape.

[Fig 1]

zig zag

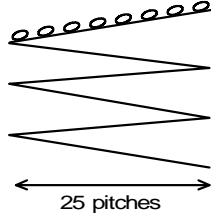

The unloading direction : Right
 The hold down tape : Upper
 The product body : Left along the unloading direction

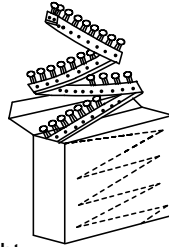

[FIG.2]

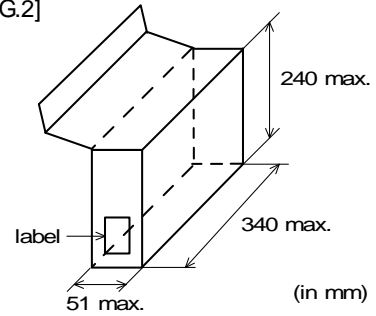

12. Marking on package

12.1 Unit Package

Bulk : Marked on a plastic bag.

Taping : Marked on a label stuck on an ammo package.

Marking on a unit package consists of :

Customer part number, MURATA part number, Inspection number(*1), RoHS marking (*2), Quantity, etc

*1) « Expression of Inspection No. »

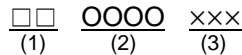

(1) Factory Code

(2) Date

First digit : Year / Last digit of year

Second digit : Month / Jan. to Sep. → 1 to 9, Oct. to Dec. → O,N,D

Third, Fourth digit : Day

(3) Serial No.

*2) « Expression of RoHS marking »

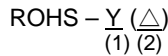

(1) RoHS regulation conformity parts.

(2) MURATA classification number

12.2 Container

Marking on the label stuck on a container consists of :

Customer name Purchasing Order Number, Customer Part Number, MURATA part number, RoHS marking (*2), Quantity, etc

13. ⚠ Caution

13.1 Mounting holes

Mounting holes should be designed as specified in this specifications. (See item 8.)

Or different design from this specifications may cause cracks in ceramics which may lead to smoking / firing.

13.2 Mounting for P.C.B. (Applied only to bulk type.)

Form of mounting hole is a triangle. (See item 8.)

Product should be inserted and soldered to each holes correct way as Fig.2. (The center terminal and the other terminals become parallel when seeing a product from the side.)

Smoking and firing maybe caused by wrong way like a Fig.3. (The center terminal and the other terminals cross when seeing a product from the side.)

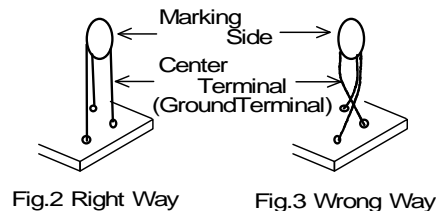

13.3 Caution for the product angle adjust work

Take care not to apply any mechanical stress to product body at the lead terminal bending process for product angle adjustment after insertion.

13.4 Limitation of Applications

Please contact us before using our products for the applications listed below which require especially high reliability for the prevention of defects which might directly cause damage to the third party's life, body or property.

- | | |
|--------------------------------------------------------------|------------------------------------------------------------------------------------------------------------------|
| (1) Aircraft equipment | (7) Traffic signal equipment |
| (2) Aerospace equipment | (8) Disaster prevention / crime prevention equipment |
| (3) Undersea equipment | (9) Data-processing equipment |
| (4) Power plant control equipment | (10) Applications of similar complexity and /or reliability requirements to the applications listed in the above |
| (5) Medical equipment | |
| (6) Transportation equipment (vehicles, trains, ships, etc.) | |

14. Notice

14.1 Soldering

- (1) Use rosin-based flux. Do not use strong acidic flux with halide content exceeding 0.2(wt)% (chlorine conversion value).

Use Sn-3.0Ag-0.5Cu solder

- (2) Standard flow soldering profile.

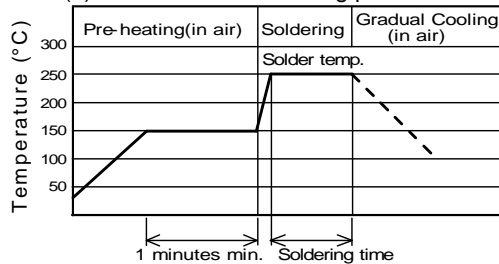

Solder temperature	Soldering time
250~260 °C	4~6s

- (3) Resistance to soldering iron goes in the following condition that tip temperature is 350 °C max. and soldering time is 5 s max.
- (4) Products and the leads should not be subject to any mechanical stress during soldering process. (and also while subject to the equivalent high temperature.)

14.2 Cleaning

Products shall be cleaned on following conditions.

- (1) Cleaning Temperature: 60°C max. (40°C max. for Isopropyl alcohol).
- (2) Ultrasonic cleaning shall comply with the following conditions, avoiding the resonance phenomenon at the mounted products and P.C.B.
Power : 20W / l max. / Frequency : 28kHz ~ 40kHz / Time : 5 minutes max.
- (3) Cleaning agent
1. alcohol cleaning agents.
 - Isopropyl alcohol (IPA)
 2. Aqueous cleaning agent
 - Pine Alpha ST-100S
- (4) Ensure that residual flux and residual cleaning agent is completely removed.
Products should be thoroughly dried after aqueous agent has been removed with de-ionized water.
- (5) For other cleaning methods, please contact Murata engineering.

14.3 Operating Environment

- (1) Do not use products in corrosive gases such as chlorine gas, acid or sulfide gas.
- (2) Do not use products in the environment where water, oil or organic solvents may adhere to products.
- (3) Do not adhere any resin to products, coat nor mold products with any resin (including adhesive) to prevent mechanical and chemical stress on products.

14.4 Storage and handling requirements.

(1) Storage period

Use the products within 12 months after delivered.

Solderability should be checked if this period is exceeded.

(2) Storage environment condition

To prevent products quality deterioration, storage conditions should be controlled as follows ;

1. Temperature : -10 to 40 degrees centigrade

2. Humidity : 15 to 85% relative humidity

3. Products should be stored without sudden changes in temperature and humidity.

Don't keep products in corrosive gases such as sulfur, chlorine gas or acid, or it may cause oxidization of lead terminals resulting in poor solderability.

4. Products should be stored on the palette for the prevention of the influence from humidity, dust and so on.

5. Products should be stored in the warehouse without heat shock, vibration, direct sunlight and so on.

(3) Handling Conditions

Care should be taken when transporting or handling product to avoid excessive vibration or mechanical shock.

15.  Note

(1) Please make sure that your product has been evaluated in view of your specifications with our product being mounted to your product.

(2) You are requested not to use our product deviating from the reference specifications.

(3) The contents of this reference specification are subject to change without advance notice. Please approve our product specifications or transact the approval sheet for product specifications before ordering.

X-ON Electronics

Largest Supplier of Electrical and Electronic Components

Click to view similar products for [Feed Through Capacitors](#) category:

Click to view products by [Murata](#) manufacturer:

Other Similar products are found below :

[PSM4-402Z-20B](#) [CKD110JB1E470S](#) [CKD510JB1E473S](#) [CKD510JB1H221S](#) [CKD510JB1H470S](#) [4700-003MLF](#) [4700-053LF](#) [4701-001MLF](#) [4701-002MLF](#) [SSM1-402E-10B](#) [SSM1-501P-10T1](#) [SSM1-402E-10T1](#) [SSM1-152P-05T1](#) [4700-009MLF](#) [SSM1-101Z-05B](#) [SSM1F-402E-10T1](#) [SSM1-202P-05T1](#) [0805J0500471MATE03](#) [PSM4-103Z-20T0](#) [0805J1000470MATE03](#) [SF0603C101SBNBB](#) [PSM4F-402Z-20T0](#) [CX0603MRX7R6BB104](#) [CX1206MKX7R9BB104](#) [CX0603MRX7R9BB103](#) [YFF15PC0J105MT000N](#) [NFM15CC222D1A3D](#) [NFM15CC223C1C3D](#) [NFM15CC223C1A3D](#) [NFM18PC225B1A3D](#) [CX0603MRX5R6BB224](#) [CX0603MRX7R9BB103](#) [CX0805MRX7R0BB103](#) [CX0805MRX7R8BB223](#) [CX1206MKX7R7BB224](#) [CX1206MKX7R9BB104](#) [NFM31HK104R1H3L](#) [NFM31HK223R1H3L](#) [NFM15PC224R1A3D](#) [DSS1NB32A223Q91A](#) [DSS1NB31H104Q91A](#) [NFE31PT101C1E9L](#) [NFE31PT220R1E9L](#) [NFE61PT330B1H9L](#) [NFE61PT681B1H9L](#) [NFM31KC104R1H3L](#) [NFM41CC223R2A3L](#) [DSS1NB32A103Q91A](#) [DSS1NB32A102Q91A](#) [NFE31PT471F1E9L](#)