

W-LAN+Bluetooth[®] Combo Module Data Sheet

Infineon CYW4373E Chipset
for 802.11a/b/g/n/ac + Bluetooth[®] 5.2

Design Name: Type2AE
Tentative P/N : LBEE5PK2AE-564
Sample P/N : LBEE5PK2AE-SMP

This Datasheet is preliminary version, and subject to change without notice

Revision History

Revision Code	Date	Description	Comments
-	July 9 th 2020	First Issue	
A	Dec 10 th 2020	<ul style="list-style-type: none"> • Scope • Rating • Operating Condition • DC / RF Characteristics • Tape and Reel Packing • Cleaning • Regulatory statement 	Update
B	Dec 17 th 2020	<ul style="list-style-type: none"> • Part Number • Dimensions, Marking and Terminal Configurations • DC / RF Characteristics 11.7.2 Low Rate Condition for IEEE802.11n(HT40) – 5GHz • Tape and Reel Packing 	Correction
C	Apr 30 th 2021	<ul style="list-style-type: none"> • DC / RF Characteristics 	Update
D	Dec 17 th 2021	<ul style="list-style-type: none"> • Module height 	Update
E	Dec 29 th 2021	<ul style="list-style-type: none"> • Bandgap reference resistor to 4.75K ohm +/-1%. 	Update
F	Feb 16 th 2022	<ul style="list-style-type: none"> • Scope BT 5.2 • Bluetooth® QDID 	Update
G	Apr 6 th 2022	<ul style="list-style-type: none"> • Scope Host Interface • Block Diagram • Terminal Configuration • Strapping Option • DC / RF Characteristics 	Update
H	June 14 th 2022	<ul style="list-style-type: none"> • Scope IC P/N 	update

TABLE OF CONTENTS

Revision History.....	1
1. Scope	4
2. Part Number	4
3. Block Diagram	4
4. Certification Information	5
4.1. Radio Certification	5
4.2. Bluetooth® Qualification	5
5. Dimensions, Marking and Terminal Configurations	6
6. Rating	12
7. Operating Condition	12
7.1. Operating condition	12
7.2. External LPO signal Requirement	12
8. Power Up Sequence	13
8.1. Power Up Sequence for WLAN ON, and BT ON	13
8.2. Power Up Sequence for WLAN ON, and BT OFF	13
8.3. Power Up Sequence for WLAN OFF, and BT ON.....	14
8.4. Power Up Sequence for WLAN OFF, and BT OFF.....	14
9. Digital I/O Requirements	15
9.1. Digital I/O Pins.....	15
9.2. RF Switch Control Output Pins	15
10. Interface Timing.....	16
10.1. SDIO Timing (Default Mode)	16
10.2. SDIO Timing (High Speed Mode)	17
10.3. SDIO BUS Timing Specifications in SDR Modes	18
10.4. SDIO Timing Specifications in DDR50 Mode	21
10.5. UART Timing (Default Mode).....	22
10.6. Bluetooth® PCM Timing	23
10.6.1. Short Frame Sync, Master Mode	23
10.7. Short Frame Sync, Slave Mode.....	24
10.8. Long Frame Sync, Master Mode.....	24
10.9. Long Frame Sync, Slave Mode.....	25
10.9.1. Short Frame Sync, Burst Mode.....	25
10.9.2. Long Frame Sync, Burst Mode.....	26
11. DC / RF Characteristics.....	27
11.1. DC/RF Characteristics for IEEE802.11b - 2.4GHz	27
11.1.1. High Rate Condition for IEEE802.11b – 2.4GHz.....	27
11.1.2. Low Rate Condition for IEEE802.11b – 2.4GHz	28
11.2. DC/RF Characteristics for IEEE802.11g - 2.4GHz	29
11.2.1. High Rate Condition for IEEE802.11g – 2.4GHz.....	29
11.2.2. Low Rate Condition for IEEE802.11g – 2.4GHz	30
11.3. DC/RF Characteristics for IEEE802.11n – 2.4GHz.....	31
11.3.1. High Rate Condition for IEEE802.11n – 2.4GHz.....	31
11.3.2. Low Rate Condition for IEEE802.11n – 2.4GHz.....	32
11.4. DC/RF Characteristics for IEEE802.11a - 5GHz.....	33
11.4.1. High Rate Condition for IEEE802.11a – 5GHz.....	33
11.4.2. Low Rate Condition for IEEE802.11a – 5GHz	34
11.5. DC/RF Characteristics for IEEE802.11n(HT20) - 5GHz.....	34
11.5.1. High Rate Condition for IEEE802.11n(HT20) – 5GHz.....	34
11.5.2. Low Rate Condition for IEEE802.11n(HT20) – 5GHz	35
11.6. DC/RF Characteristics for IEEE802.11ac(HT20) - 5GHz	35
11.6.1. High Rate Condition for IEEE802.11ac(VHT20) – 5GHz.....	35
11.6.2. Low Rate Condition for IEEE802.11ac(VHT20) – 5GHz	36
11.7. DC/RF Characteristics for IEEE802.11n(HT 40MHz) - 5GHz.....	36
11.7.1. High Rate Condition for IEEE802.11n(HT40) – 5GHz.....	36
11.7.2. Low Rate Condition for IEEE802.11n(HT40) – 5GHz	37
11.8. DC/RF Characteristics for IEEE802.11ac(VHT 40MHz) - 5GHz.....	37

Preliminary

< Specification may be changed by Murata without notice >
Murata(China) Investment Co., Ltd.

11.8.1. High Rate Condition for IEEE802.11ac(VHT40) – 5GHz.....	37
11.8.2. Low Rate Condition for IEEE802.11ac(VHT40) – 5GHz.....	38
11.9. DC/RF Characteristics for IEEE802.11ac(VHT 80MHz) - 5GHz.....	38
11.9.1. High Rate Condition for IEEE802.11ac(VHT80) – 5GHz.....	38
11.9.2. Low Rate Condition for IEEE802.11ac(VHT80) – 5GHz.....	39
11.10. DC/RF Characteristics for Bluetooth®.....	40
11.11. DC/RF Characteristics for Bluetooth® (LE).....	41
12. Land Patterns.....	42
13. Reference Circuit.....	43
14. Tape and Reel Packing.....	45
15. Notice.....	48
15.1. Storage Conditions.....	48
15.2. Handling Conditions.....	48
15.3. Standard PCB Design (Land Pattern and Dimensions).....	48
15.4. Notice for Chip Placer :.....	48
15.5. Soldering Conditions :.....	48
15.6. Cleaning :.....	49
15.7. Operational Environment Conditions :.....	49
15.8. Input Power Capacity :.....	49
16. Regulatory Statements.....	50
16.1. FCC Statements.....	50
16.2. IC Statements.....	50
17. PRECONDITION TO USE OUR PRODUCTS.....	51

 Please be aware that an important notice concerning availability, standard warranty and use in critical applications of Murata products and disclaimers thereto appears at the end of this specification sheet.

1. Scope

This specification is applied to the IEEE802.11a/b/g/n/ac W-LAN + Bluetooth® 5.2 combo module.

- Host Interface
 - WLAN :SDIO or USB(Shared)
 - BT/BLE :UART or USB(Shared)
- IC P/N : Infineon / CYW4373E
- Reference Clock : Reference clock embedded
- Weight : 0.2g
- RoHS : This component can meet with RoHS compliance.
- MSL* : Level 3

*This product is moisture sensitive. Please check the detail in 15.1 Storage Condition section.

2. Part Number

Ordering Part Number	Description
LBEE5PK2AE-EVB	In case of EVB order
LBEE5PK2AE-SMP	In case of sample order
LBEE5PK2AE-564	Mass Produced Product

“Type2AE” is design name of this module. Design name may be used in certification test report.

3. Block Diagram

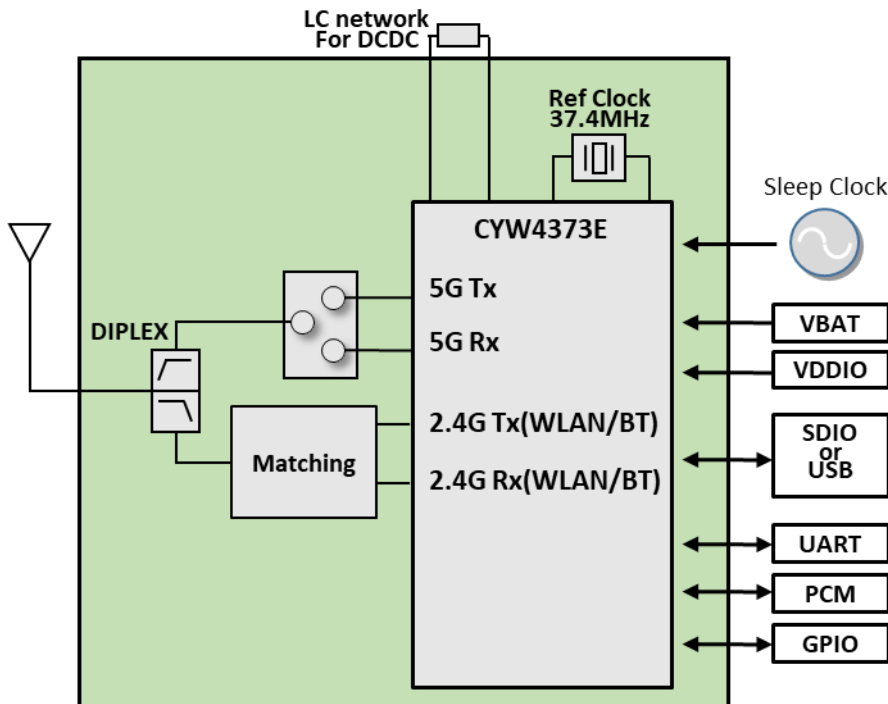

4. Certification Information

4.1. Radio Certification

USA/Canada

FCC ID : T.B.D.

IC : T.B.D

*Please follow installation manual of Appendix

Europe

T.B.D.

4.2. Bluetooth® Qualification

QDID: 173411

5. Dimensions, Marking and Terminal Configurations

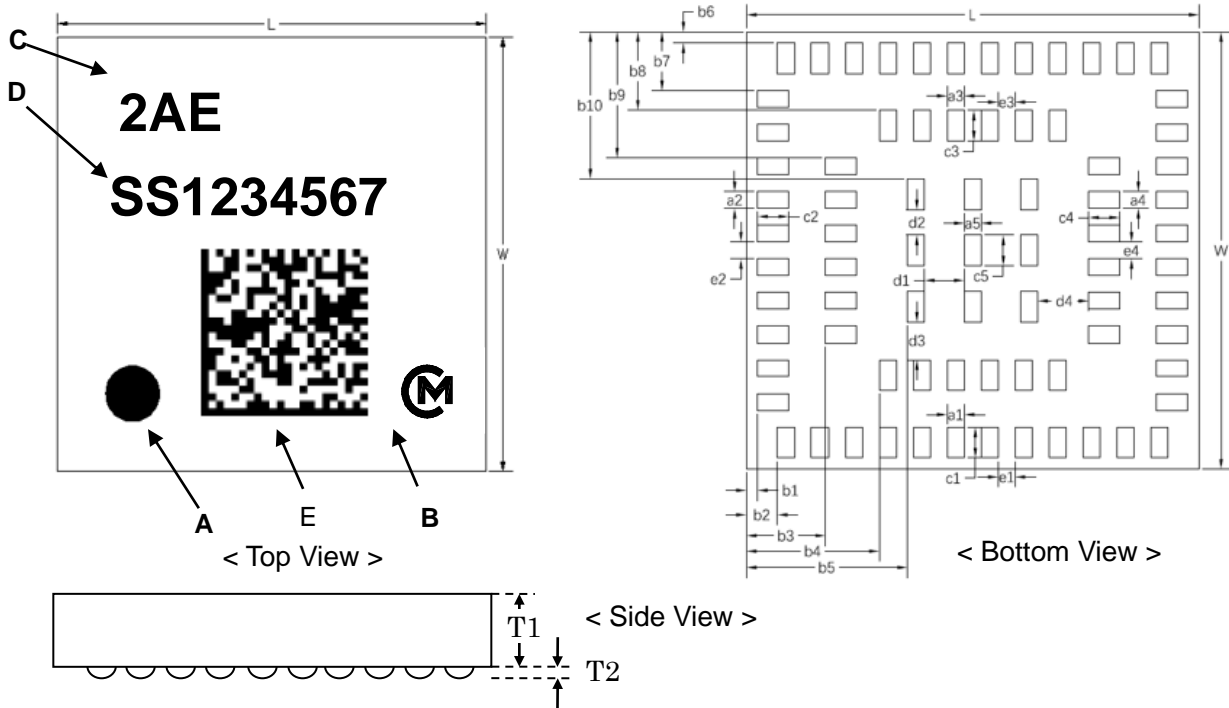

Marking	Meaning
A	Pin 1 Marking
B	Murata Logo
C	Module Type
D	Inspection Number
E	2D Code (Internal use)

Mark	Dimension	Mark	Dimension	Mark	Dimension
L	8.00±0.20	W	7.80±0.20	T1	1.15 max
a1	0.30±0.10	a2	0.30±0.10	a3	0.30±0.10
a4	0.30±0.10	a5	0.30±0.10	b1	0.30±0.15
b2	0.55±0.15	b3	1.50±0.15	b4	2.35±0.15
b5	2.85±0.15	b6	0.30±0.15	b7	1.05±0.15
b8	1.50±0.15	b9	2.25±0.15	b10	2.675±0.15
c1	0.45±0.10	c2	0.45±0.10	c3	0.45±0.10
c4	0.45±0.10	c5	0.45±0.10	d1	0.70±0.10
d2	0.55±0.10	d3	0.725±0.10	d4	0.90±0.10
e1	0.30±0.10	e2	0.30±0.10	e3	0.30±0.10
e4	0.30±0.10			T2	0.045±0.025

(unit : mm)

Structure

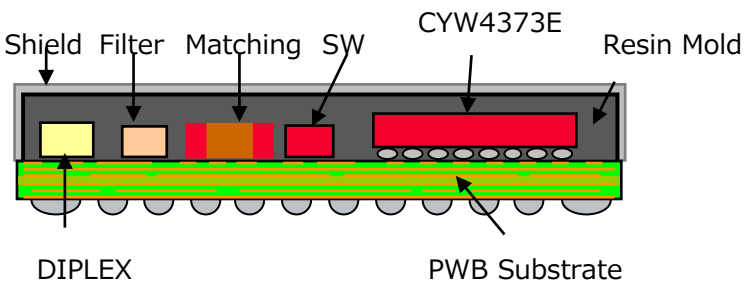

Pin Layout

<TOP View>

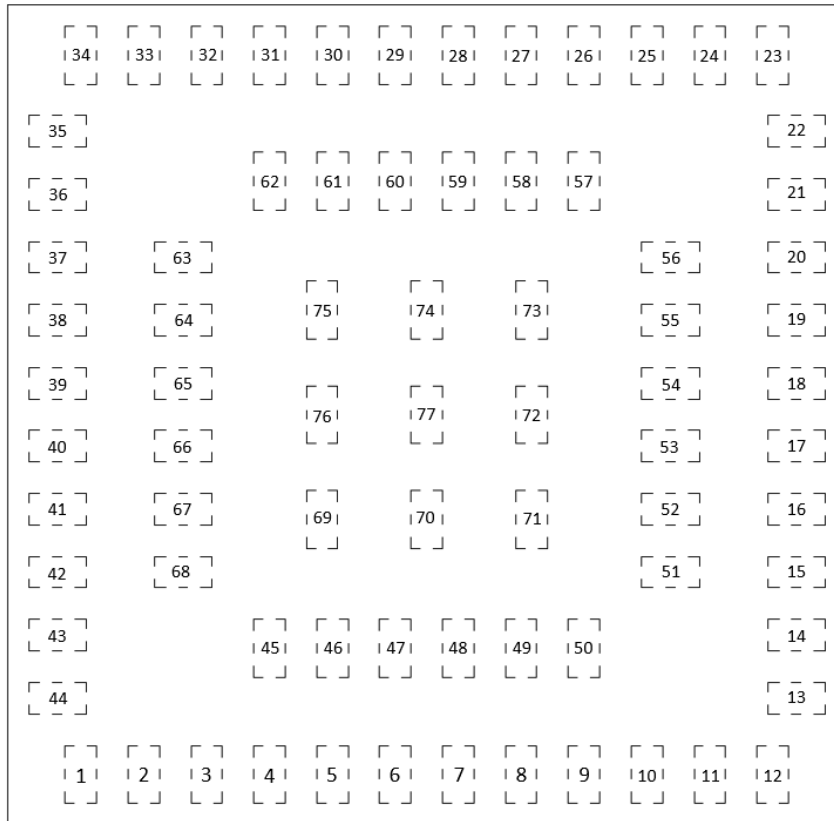

No.	Terminal Name	No.	Terminal Name	No.	Terminal Name	No.	Terminal Name
1	GND	21	GND	41	GND	61	NC
2	SR_VLX	22	WL_ANT	42	VDDIO	62	NC
3	VBAT	23	GND	43	VIN_LDO	63	TRST_L
4	WL_REG_EN	24	GND	44	NC	64	JTAG_TDI
5	LPO_IN	25	RF_SW_CTRL_5	45	GPIO_1	65	JTAG_TDO
6	BT_PCM_IN	26	RF_SW_CTRL_0	46	USB2_DM	66	JTAG_TCK/SWCLK
7	BT_PCM_CLK	27	GND	47	USB2_DP	67	JTAG_TMS/SWDIO
8	BT_PCM_SYNC	28	SDIO_CMD	48	USB2_MONCDR	68	BT_REG_EN
9	BT_PCM_OUT	29	SDIO_DATA_1	49	USB2_AVDD33	69	GND
10	BT_UART_TXD	30	SDIO_DATA_0	50	USB2_RREF	70	GND
11	BT_UART_CTS_N	31	SDIO_DATA_3	51	BT_DEV_WAKE	71	GND
12	BT_UART_RXD	32	SDIO_DATA_2	52	WL_HOST_WAKE	72	GND
13	BT_UART_RTS_N	33	SDIO_CLK	53	JTAG_SEL	73	GND
14	GND	34	GND	54	STRAP_1	74	GND
15	NC	35	NC	55	STRAP_2	75	GND
16	GND	36	NC	56	STRAP_0	76	GND
17	BT HOST WAKE	37	NC	57	GND	77	GND
18	BT_GPIO_2	38	NC	58	NC		
19	BT_GPIO_3	39	NC	59	NC		
20	BT_GPIO_5	40	NC	60	NC		

No.	Terminal Name	Type	Connection to IC Terminal	Description
1	GND	-	-	-
2	SR_VLX	PO	SR_VLX	CBUCK switching regulator output. Refer to Reference circuit for details of the inductor and capacitor required in this output.
3	VBAT	PI	SR_VDDBAT5V/LDO_VD DBAT5V	Supply to internal Power source of VBAT
4	WL_REG_EN	I	WL_REG_ON	Used by PMU to power-up or power down the internal CYW4373E regulators used by the WLAN section. Also, when deasserted, this pin holds the WLAN section in reset. This pin has an internal 200 kΩ pull-down resistor that is enabled by default. It can be disabled through programming.
5	LPO_IN	I	LPO_IN	External Sleep clock input(32.768kHz)
6	BT_PCM_IN	I	BT_PCM_IN	PCM data input.
7	BT_PCM_CLK	I/O	BT_PCM_CLK	PCM clock; can be master(output) or slave(input).
8	BT_PCM_SYNC	I/O	BT_PCM_SYNC	PCM sync; can be master(output) or slave(input).
9	BT_PCM_OUT	O	BT_PCM_OUT	PCM data output
10	BT_UART_TXD	O	BT_UART_TXD	UART serial output. Serial data output for the HCI UART interface.
11	BT_UART_CTS_N	I	BT_UART_CTS_N	UART clear – to - send. Active - low clear – to - send signal for the HCI UART interface.
12	BT_UART_RXD	I	BT_UART_RXD	UART serial input. Serial data input for the HCI UART interface.
13	BT_UART_RTS_N	O	BT_UART_RTS_N	UART request – to - send. Active - low request - to-send signal for the HCI UART interface.
14	GND	-	-	-
15	NC	-	-	-
16	GND	-	-	-
17	BT HOST WAKE	I/O	BT HOST WAKE	Host wake-up. Signal from the CYW4373E to the host indicating that the CYW4373E requires attention. The polarity of this signal is software configurable and can be asserted high or low.
18	BT_GPIO_2	I/O	BT_GPIO_2	Bluetooth® general-purpose I/O.
19	BT_GPIO_3	I/O	BT_GPIO_3	Bluetooth® general-purpose I/O.
20	BT_GPIO_5	I/O	BT_GPIO_5	Bluetooth® general-purpose I/O.
21	GND	-	-	-
22	WL_ANT	RF	-	RF output for WLAN/BT
23	GND	-	-	-
24	GND	-	-	-
25	RF_SW_CTRL_5	O	RF_SW_CTRL_5	Programmable RF switch control lines. The control lines are programmable via the driver and NVRAM file.

No.	Terminal Name	Type	Connection to IC Terminal	Description
26	RF_SW_CTRL_0	O	RF_SW_CTRL_0	Programmable RF switch control lines. The control lines are programmable via the driver and NVRAM file.
27	GND	-	-	-
28	SDIO_CMD	I/O	SDIO_CMD	SDIO command line
29	SDIO_DATA_1	I/O	SDIO_DATA_1	SDIO data line 1
30	SDIO_DATA_0	I/O	SDIO_DATA_0	SDIO data line 0
31	SDIO_DATA_3	I/O	SDIO_DATA_3	SDIO data line 3
32	SDIO_DATA_2	I/O	SDIO_DATA_2	SDIO data line 2
33	SDIO_CLK	I	SDIO_CLK	SDIO clock input
34	GND	-	-	-
35	NC	-	-	-
36	NC	-	-	-
37	NC	-	-	-
38	NC	-	-	-
39	NC	-	-	-
40	NC	-	-	-
41	GND	-	-	-
42	VDDIO	PI	VDDIO/BT_VDDO	Supply for PMU, BT, WLAN, SDIO.
43	VIN_LDO	PI	LDO_VDD1P5/WRF_AFE_VDD1P35/ WRF_XTAL_VDD1P35/WRF_PMU_VDD1P35	Input for LDO_VDD1P5/WRF_AFE_VDD1P35/ WRF_XTAL_VDD1P35/WRF_PMU_VDD1P35
44	NC	-	-	-
45	GPIO_1	I/O	GPIO_1	Programmable GPIO Pin
46	USB2_DM	I/O	USB2_DM	Data minus of shared USB2.0 port.
47	USB2_DP	I/O	USB2_DP	Data plus of shared USB2.0 port.
48	USB2_MONCDR	O	USB2_MONCDR	CDR monitor for debug.
49	USB2_AVDD33	PI	USB2_AVDD33	Power Supply for shared USB2.0. When VBAT is between 3.6V to 4.8V connect to VOUT_3P3 i.e. 3.3V output of LDO3P3. When VBAT is 3.3V connect directly to VBAT.
50	USB2_RREF	I/O	USB2_RREF	Bandgap reference resistor; 4.75K ohm +/-1% for USB. DNI for SDIO.
51	BT_DEV_WAKE	I	BT_DEV_WAKE	Bluetooth® device wake-up: Signal from the host to the CYW4373E indicating that the host requires attention. The polarity of this signal is software configurable and can be asserted high or low
52	WL_HOST_WAKE	O	GPIO_0	Programmable GPIO Pin
53	JTAG_SEL	I	JTAG_SEL	JTAG select. This pin must be kept NO CONNECT if the JTAG interface is not used. It must be high to select SWD OR JTAG. When JTAG_SEL = 1: <ul style="list-style-type: none"> ■ GPIO_2 is TCK ■ GPIO_3 is TMS ■ GPIO_4 is TDIO ■ GPIO_5 is TDO

No.	Terminal Name	Type	Connection to IC Terminal	Description
				■ GPIO_6 is TRST_L
54	STRAP_1	I	STRAP_1	0: SDIO only
55	STRAP_2	I	STRAP_2	USB_DISABLE 1:USB disable 0: USB enable
56	STRAP_0	I	STRAP_0	SDIO_PADVDDIO sel
57	GND	-	-	-
58	NC	-	-	-
59	NC	-	-	-
60	NC	-	-	-
61	NC	-	-	-
62	NC	-	-	-
63	TRST_L	I/O	GPIO_6	GPIO_6 is TRST_L
64	JTAG_TDI	I/O	GPIO_4	GPIO_4 is TDI
65	JTAG_TDO	I/O	GPIO_5	GPIO_5 is TDO
66	JTAG_TCK/SWCLK	I/O	GPIO_2	GPIO_2 is TCK/SWCLK
67	JTAG_TMS/SWDIO	I/O	GPIO_3	GPIO_3 is TMS/SWDIO
68	BT_REG_EN	I	BT_REG_ON	Used by PMU to power-up or power down the internal CYW4373E regulators used by the Bluetooth® section. Also, when deasserted, this pin holds the Bluetooth® section in reset. This pin has an internal 200 kΩ pull-down resistor that is enabled by default. It can be disabled through programming.
69	GND	-	-	-
70	GND	-	-	-
71	GND	-	-	-
72	GND	-	-	-
73	GND	-	-	-
74	GND	-	-	-
75	GND	-	-	-
76	GND	-	-	-
77	GND	-	-	-

SDIO Pin Description

No.	Pin Name	(i) SD 4-bit Mode		(ii) SD 1-bit Mode	
20	SDIO_CLK	CLK	Clock	CLK	Clock
17	SDIO_D0	DATA0	Data line 0	DATA	Data line
15	SDIO_D1	DATA1	Data line 1 /Interrupt	IRQ	Interrupt
16	SDIO_D2	DATA2	Data line 2	NC	Not used
14	SDIO_D3	DATA3	Data line 3	NC	Not used
18	SDIO_CMD	CMD	Command line	CMD	Command line

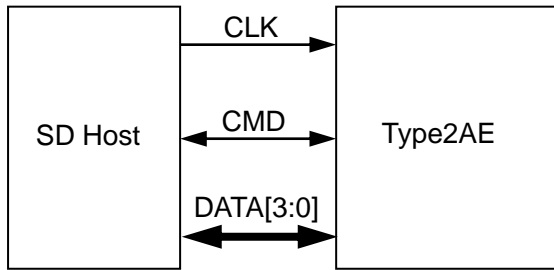

(i) SD 4-bit Mode

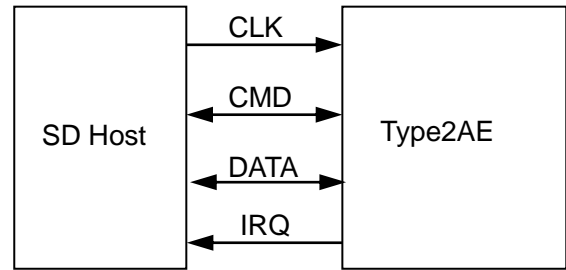

(ii) SD 1-bit Mode

Strapping Options

Mode Select	STRAP_2	STRAP_1	STRAP_0
USB	0	0	0
SDIO only	1	0	0 = SDIO is 3.3V 1 = SDIO is 1.8V

6. Rating

Parameter		Min	Max	Unit
Storage Temperature		-40	+85	deg.C
Supply Voltage	VBAT	-0.5	5.5	V
	VDDIO	-0.5	3.9	V

* Stresses in excess of the absolute ratings may cause permanent damage. Functional operation is not implied under these conditions. Exposure to absolute ratings for extended periods of time may adversely affect reliability. No damage assuming only one parameter is set at limit at a time with all other parameters are set within operating condition.

7. Operating Condition

7.1. Operating condition

Parameter		Min	Typ	Max	Unit
Operating Temperature Range ¹		-40	+25	+85	deg.C
Supply Voltage	VBAT	3.13 ^{*1}	3.3	3.5 ^{*2}	V
	VDDIO	1.62	1.8	1.98	V
		2.97	3.3	3.63	V

*1 CYW4373E is functional across this range of voltages. Optimal RF performance specified in the data sheet, however, is guaranteed only for VBAT = 3.3V +/- 5%.

*2 The maximum continuous voltage is 4.8V.

7.2. External LPO signal Requirement

Parameter	External LPO Clock	Unit
Nominal input frequency	32.768	kHz
Frequency accuracy	+/-200	ppm
Duty cycle	30-70	%
Input signal amplitude	200 - 3300	mV, p-p
Signal type	Square-wave or sine-wave	-
Input impedance ^{*a}	> 100k	ohm
	< 5	pF
Clock jitter (during initial start-up)	<10,000	ppm

a) When power is applied or switch off.

¹ Functionality is guaranteed but specifications require derating at extreme temperatures

8. Power Up Sequence

8.1. Power Up Sequence for WLAN ON, and BT ON

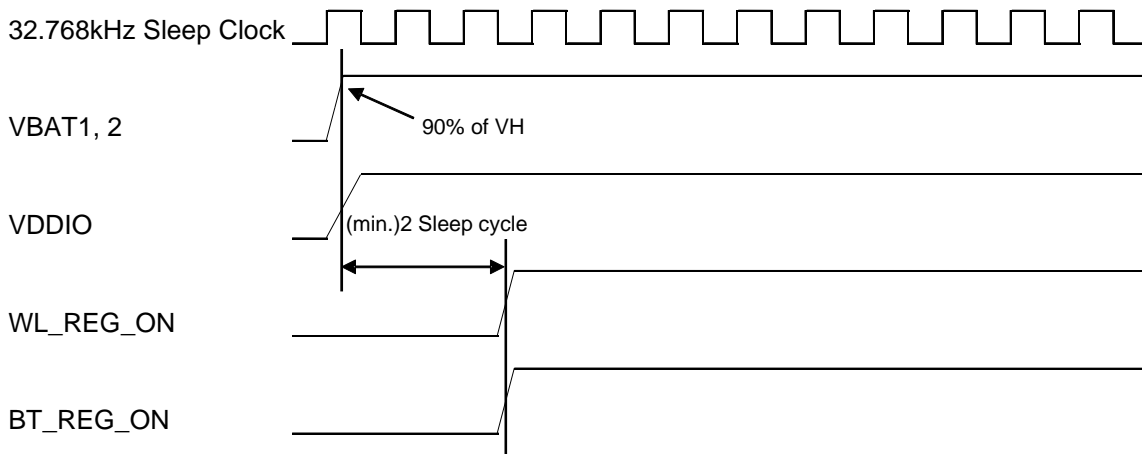

Notes:

1. VBAT should not rise 10-90% faster than 40 microseconds
2. VBAT should be up before or at the same time as VDDIO. VDDIO should NOT be present first or be held high before VBAT is high.

8.2. Power Up Sequence for WLAN ON, and BT OFF

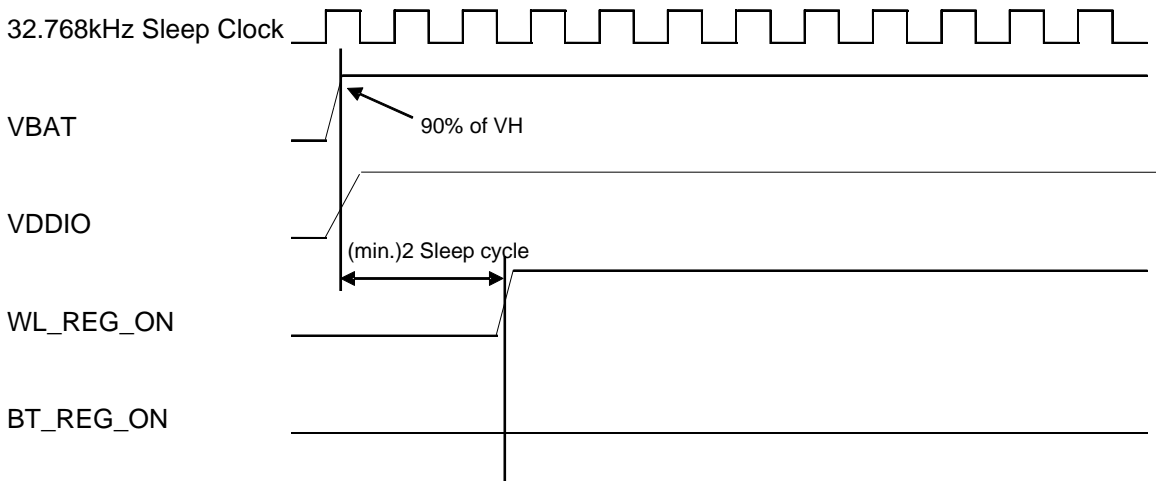

Notes:

1. VBAT should not rise 10-90% faster than 40 microseconds
2. VBAT should be up before or at the same time as VDDIO. VDDIO should NOT be present first or be held high before VBAT is high.

8.3. Power Up Sequence for WLAN OFF, and BT ON

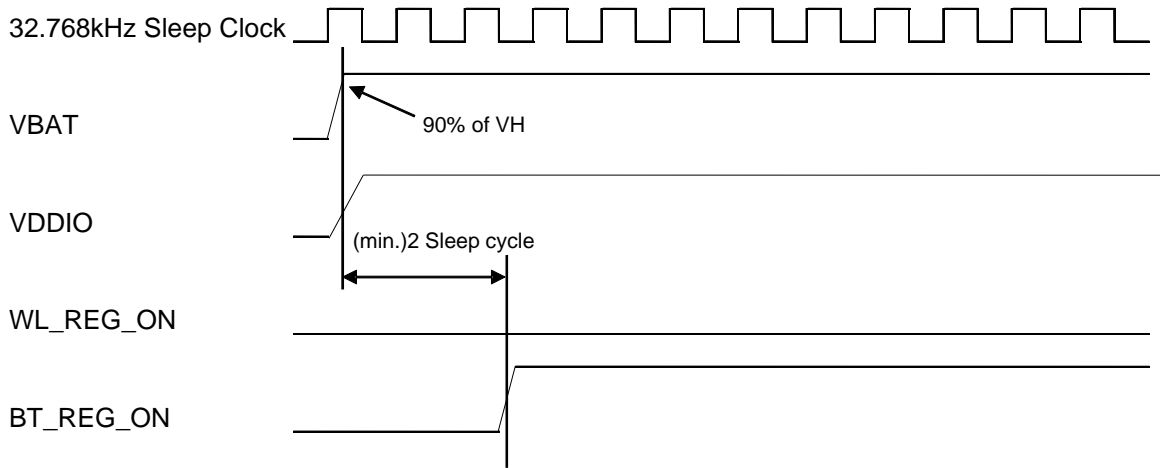

Notes:

1. VBAT should not rise 10-90% faster than 40 microseconds
2. VBAT should be up before or at the same time as VDDIO. VDDIO should NOT be present first or be held high before VBAT is high.

8.4. Power Up Sequence for WLAN OFF, and BT OFF

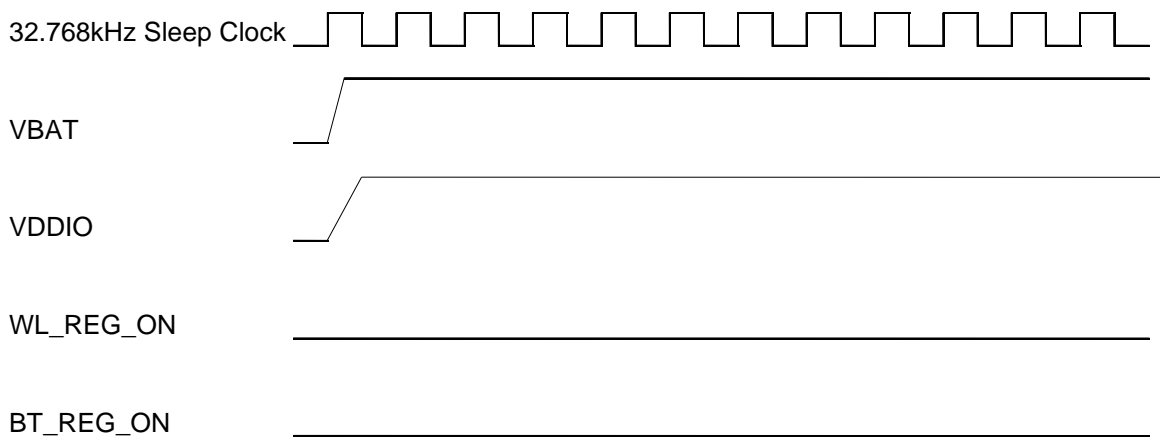

Notes:

1. VBAT should not rise 10-90% faster than 40 microseconds
2. VBAT should be up before or at the same time as VDDIO. VDDIO should NOT be present first or be held high before VBAT is high.

9. Digital I/O Requirements

9.1. Digital I/O Pins

Digital I/O Pins	Sym.	Min.	Typ.	Max.	Unit
For VDDIO = 1.8V:					
Input high voltage	V _{IH}	0.65xVDDIO	-	-	V
Input low voltage	V _{IL}	-	-	0.35xVDDIO	V
Output high voltage@2.0mA	V _{OH}	VDDIO-0.45	-	-	V
Output low voltage@2.0mA	V _{OL}	-	-	0.45	V
For VDDIO = 3.3V:					
Input high voltage	V _{IH}	2.00	-	-	V
Input low voltage	V _{IL}	-	-	0.80	V
Output high voltage@2.0mA	V _{OH}	VDDIO-0.40	-	-	V
Output low voltage@2.0mA	V _{OL}	-	-	0.40	V

9.2. RF Switch Control Output Pins

	Sym.	Min.	Typ.	Max.	Unit
For VDDIO_RF = 3.3V:					
Output high voltage@2.0mA	V _{OH}	VDDIO-0.40	-	-	V
Output low voltage@2.0mA	V _{OL}	-	-	0.40	V
Output capacitance	C _{out}	-	-	5	pF

10. Interface Timing

10.1. SDIO Timing (Default Mode)

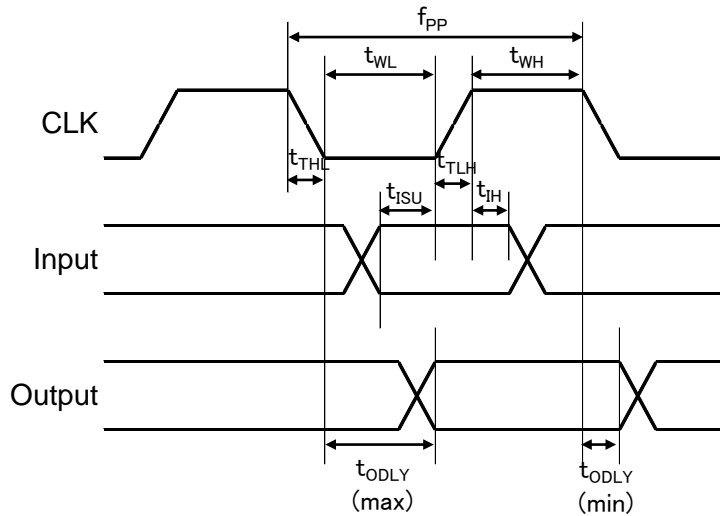

Parameter	Symbol	Min ⁽¹⁾	Typ ⁽¹⁾	Max ⁽¹⁾	Unit
Clock CLK (All values are referred to min. VIH and max. VIL ⁽²⁾)					
Frequency-Data Transfer Mode	f _{PP}	0	-	25	MHz
Frequency-Identification Mode	f _{OD}	0	-	400	kHz
Clock Low Time	t _{WL}	10	-	-	ns
Clock High Time	t _{WH}	10	-	-	ns
Clock Rise Time	t _{TLH}	-	-	10	ns
Clock Falling Time	t _{THL}	-	-	10	ns
Inputs: CMD, DAT (referenced to CLK)					
Input Setup Time	t _{ISU}	5	-	-	ns
Input Hold Time	t _{IH}	5	-	-	ns
Outputs: CMD, DAT (referenced to CLK)					
Output Delay time-Data Transfer Mode	t _{ODLY}	0	-	14	ns
Output Delay time-Identification Mode	t _{ODLY}	0	-	50	ns

(1). Timing is based on $CL \leq 40pF$ load on CMD and Data.

(2). Min (Vih) = $0.7 \cdot VDDIO$ and max (Vil) = $0.2 \cdot VDDIO$.

Preliminary

< Specification may be changed by Murata without notice >
Murata(China) Investment Co., Ltd.

10.2. SDIO Timing (High Speed Mode)

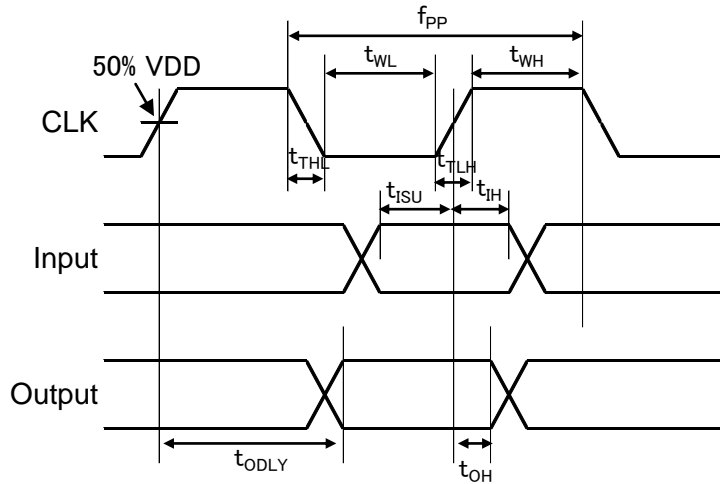

Parameter	Symbol	Min ⁽¹⁾	Typ ⁽¹⁾	Max ⁽¹⁾	Unit
Clock CLK (All values are referred to min. VIH and max. VIL ⁽²⁾)					
Frequency-Data Transfer Mode	fPP	0	-	50	MHz
Frequency-Identification Mode	fOD	0	-	400	kHz
Clock Low Time	tWL	7	-	-	ns
Clock High Time	tWH	7	-	-	ns
Clock Rise Time	tTLH	-	-	3	ns
Clock Falling Time	tTHL	-	-	3	ns
Inputs: CMD, DAT (referenced to CLK)					
Input Setup Time	tISU	6	-	-	ns
Input Hold Time	tIH	2	-	-	ns
Outputs: CMD, DAT (referenced to CLK)					
Output Delay time-Data Transfer Mode	tODLY	-	-	14	ns
Output Hold time	tOH	2.5	-	-	ns
Total System Capacitance (each line)	CL	-	-	40	pF

(1). Timing is based on $CL \leq 40\text{pF}$ load on CMD and Data.

(2). Min (Vih) = $0.7 \cdot VDDIO$ and max (Vil) = $0.2 \cdot VDDIO$.

10.3. SDIO BUS Timing Specifications in SDR Modes

Clock Timing

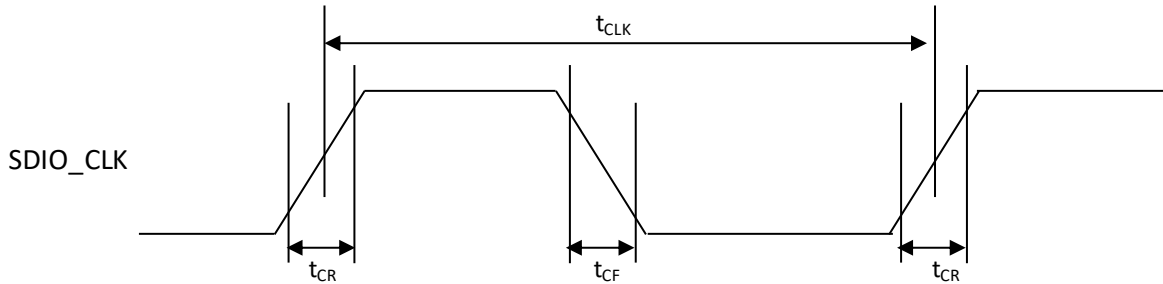

Parameter	Symbol	Min	Max	Unit	Comments
-	t_{CLK}	40	-	ns	SDR12 mode
		20	-	ns	SDR25 mode
		10	-	ns	SDR50 mode
		4.8	-	ns	SDR104 mode
-	t_{CR}, t_{CF}	-	$0.2 \times t_{CLK}$	ns	$t_{CR}, t_{CF} < 2.00\text{ns}(\text{max}) @ 100\text{MHz}, c\text{CARD}=10\text{pF}$ $t_{CR}, t_{CF} < 0.96\text{ns}(\text{max}) @ 208\text{MHz}, c\text{CARD}=10\text{pF}$
Clock duty Cycle	-	30	70	%	-

Card Input Timing

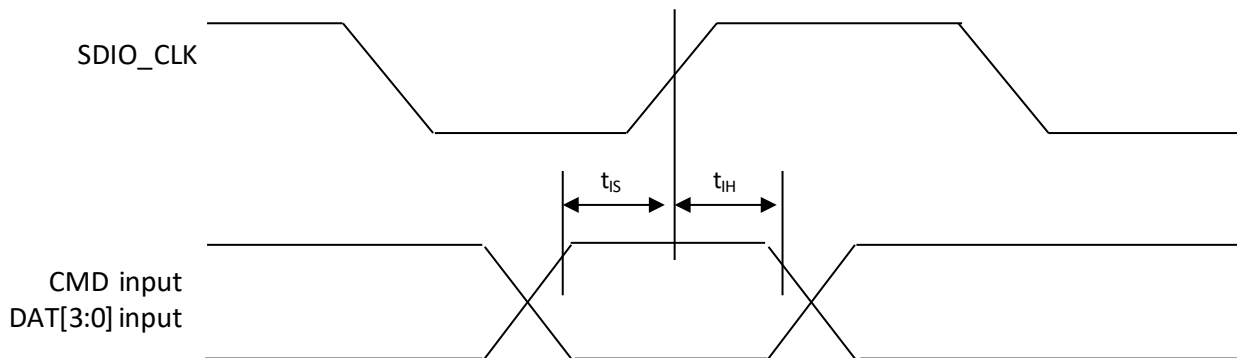

Symbol	Min	Max	Unit	Comments
SDR104 Mode				
t_{IS}	1.4	-	ns	$c\text{CARD} = 10\text{pF}, V_{CT} = 0.975\text{V}$
t_{IH}	0.8	-	ns	$c\text{CARD} = 5\text{pF}, V_{CT} = 0.975\text{V}$
SDR50 Mode				
t_{IS}	3.0	-	ns	$c\text{CARD} = 10\text{pF}, V_{CT} = 0.975\text{V}$
t_{IH}	0.8	-	ns	$c\text{CARD} = 5\text{pF}, V_{CT} = 0.975\text{V}$

Card Output Timing

SDIO Bus Output Timing (SDR Modes up to 100MHz)

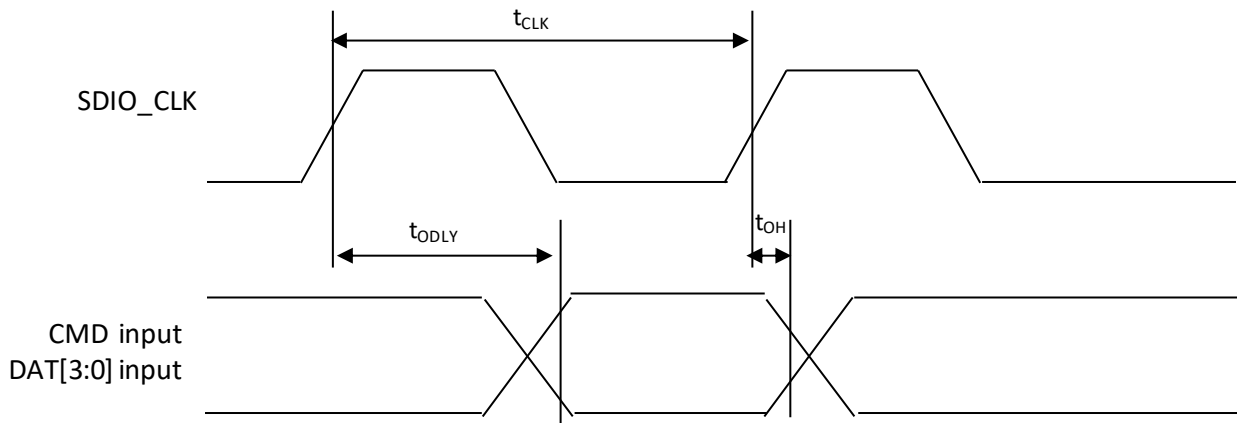

SDIO Bus Output Timing Parameters (SDR Modes up to 100MHz)

Symbol	Min	Max	Unit	Comments
tODLY	-	7.5	ns	tCLK ≥ 10ns CL = 30pF using driver type B for SDR50
tODLY	-	14.0	ns	tCLK ≥ 20ns CL = 40pF using for SDR12,SDR25
tOH	1.5	-	ns	Hold time at the tODLY(min) CL = 15pF

SDIO Bus Output Timing (SDR Modes 100MHz to 208MHz)

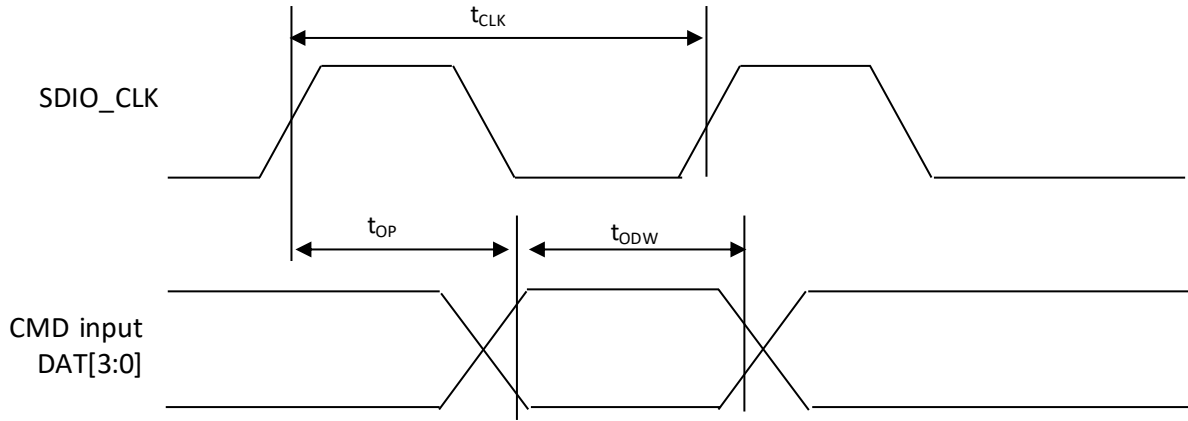

SDIO Bus Output Timing Parameters (SDR Modes 100MHz to 208MHz)

Symbol	Min	Max	Unit	Comments
tOP	0	2	UI	Card output phase
Δt_{OP}	-350	+1550	ps	Delay variation due to temp change after tuning
tODW	0.60	-	UI	tODW = 2.88ns @208MHz

- $\Delta t_{OP}=+1550ps$ for junction temperature of $\Delta t_{OP}=90^{\circ}C$ during operation.
- $\Delta t_{OP}=-350ps$ for junction temperature of $\Delta t_{OP}=-20^{\circ}C$ during operation.
- $\Delta t_{OP}=+2600ps$ for junction temperature of $\Delta t_{OP}=-20^{\circ}C$ to $+125^{\circ}C$ during operation

Δt_{OP} Consideration for Variable Data Window (SDR 104 Mode)

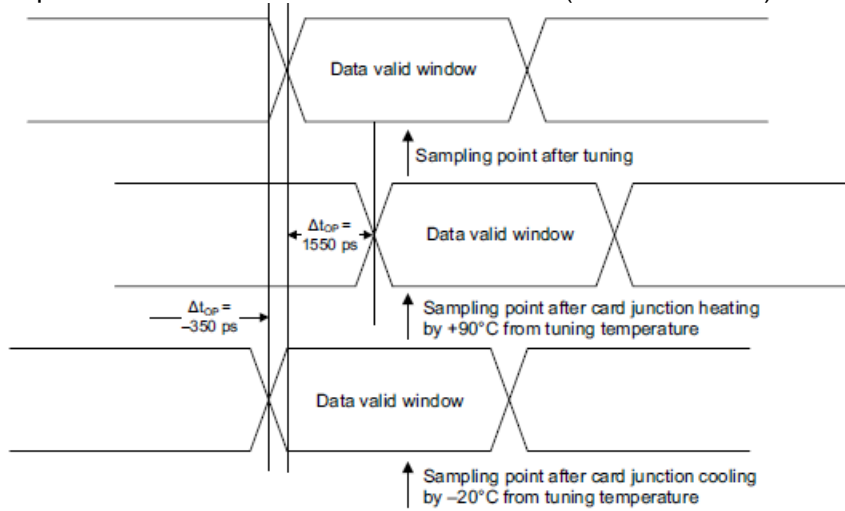

10.4. SDIO Timing Specifications in DDR50 Mode

SDIO Clock Timing (DDR50 Mode)

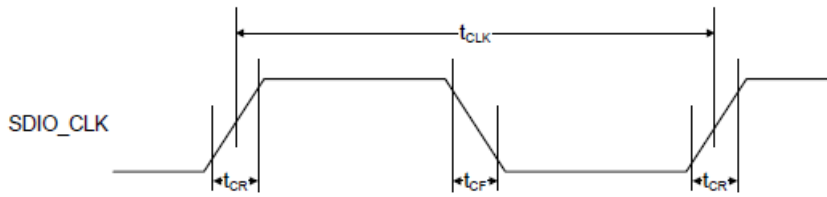

SDIO Bus Clock Timing Parameters (DDR50 Mode)

Parameter	Symbol	Min	Max	Unit	Comments
-	t _{CLK}	20	-	ns	DDr50 mode
-	t _{CR} , t _{CF}	-	0.2 x t _{CLK}	ns	t _{CR} , t _{CF} <4.00ns(max)@50MHz, cCard=10pF
Clock duty cycle	-	45	55	%	-

SDIO Data Timing (DDR50 Mode)

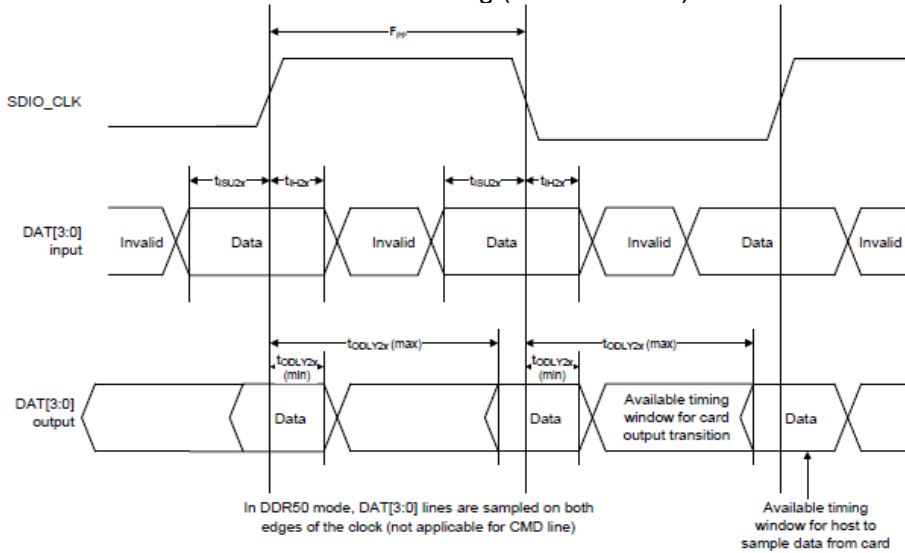

SDIO Bus Timing parameters (DDR50 Mode)

Parameter	Symbol	Min	Max	Unit	Comments
Input CMD					
Input setup time	t _{ISU}	6	-	ns	Ccard<10pF (1 card)
Input hold time	t _{IH}	0.8	-	ns	Ccard<10pF (1 card)
Output CMD					
Output delay time	t _{ODLY}	-	13.7	ns	Ccard<30pF (1 card)
Output hold time	t _{OH}	1.5	-	ns	Ccard<15pF (1 card)
Input DAT					
Input setup time	t _{ISU2x}	3	-	ns	Ccard<10pF (1 card)
Input hold time	t _{IH2x}	0.8	-	ns	Ccard<10pF (1 card)
Output DAT					
Output delay time	t _{ODLY2x}	-	7.5	ns	Ccard<25pF (1 card)
Output hold time	t _{OH2x}	1.5	-	ns	Ccard<15pF (1 card)

10.5. UART Timing (Default Mode)

The UART is a standard 4-wire interface (RX, TX, RTS, and CTS) with adjustable baud rates from 9600 bps to 4.0 Mbps. The UART supports the Bluetooth® 4.2 UART HCI specification: H4, a custom Extended H4, and H5. The default baud rate is 115.2 Kbaud.

The UART operates correctly with the host UART as long as the combined baud rate error of the two devices is within $\pm 2\%$.

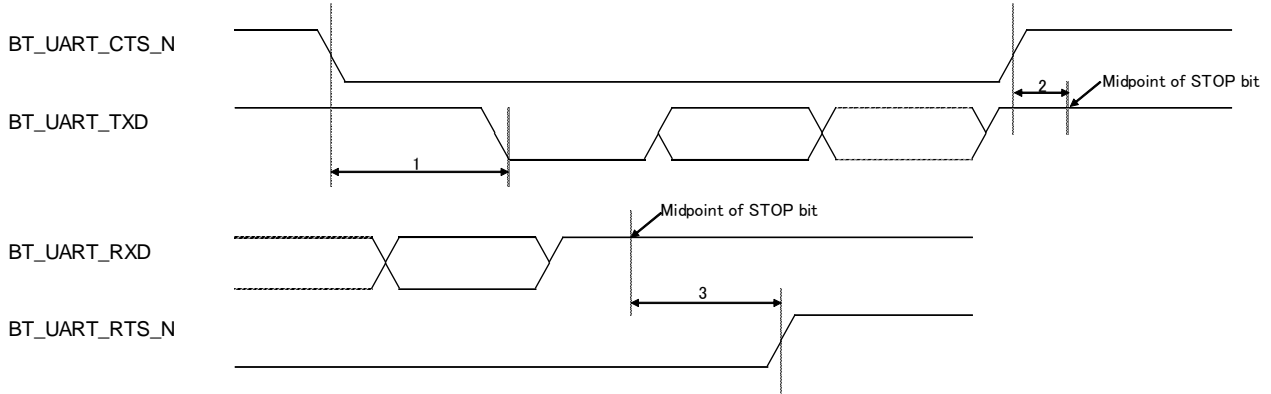

Reference	Description	Min	Typ	Max	Unit
1	Delay time, UART_CTS_N low to UART_TXD valid	-	-	1.5	Bit periods
2	Setup time, UART_CTS_N high before midpoint of stop bit	-	-	0.5	Bit periods
3	Delay time, midpoint of stop bit to UART_RTS_N high	-	-	0.5	Bit periods

Example of Common Baud Rates

Desired Rate	Actual Rate set in the module	Error (%)
4000000	4000000	0.00
3000000	3000000	0.00
921600	923077	0.16
115200	115385	0.16
57600	57692	0.16
9600	9600	0.00

10.6. Bluetooth® PCM Timing

The PCM Interface can connect to linear PCM Codec devices. In master or slave mode. In master mode, the module generates the PCM_CLK and PCM_SYNC signals, and in slave mode, these signals are provided by another master on the PCM interface and are inputs to the modules.

The PCM interface supports both short- and long-frame synchronization in both master and slave modes. In short-frame synchronization mode, the frame synchronization signal is an active-high pulse at the audio frame rate that is a single-bit period in width and is synchronized to the rising edge of the bit clock. The PCM slave looks for a high on the falling edge of the bit clock and expects the first bit of the first slot to start at the next rising edge of the clock. In long-frame synchronization mode, the frame synchronization signal is again an active-high pulse at the audio frame rate; however, the duration is three bit periods and the pulse starts coincident with the first bit of the first slot.

10.6.1. Short Frame Sync, Master Mode

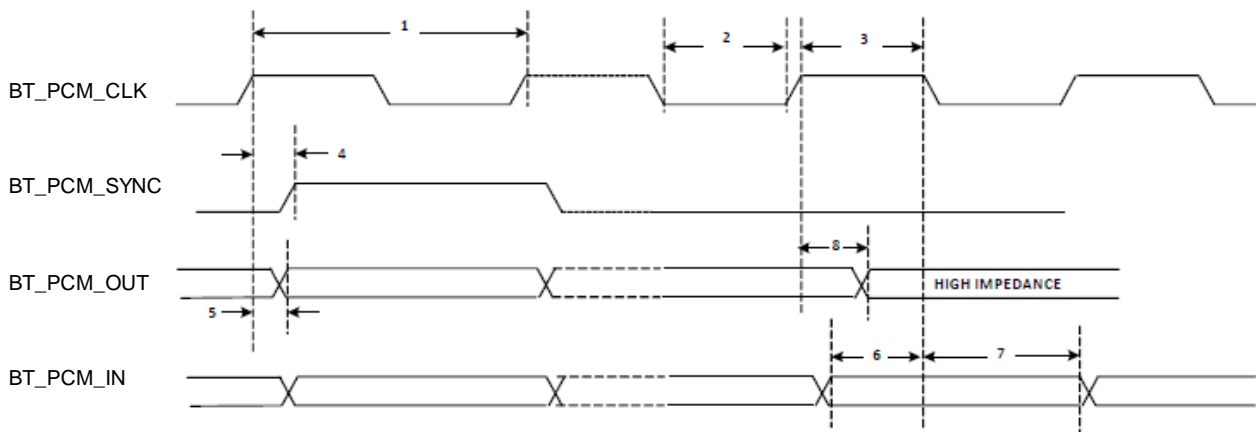

Reference	Description	Min	Typ	Max	Unit
1	PCM bit clock frequency	-	-	12	MHz
2	PCM bit clock High	41	-	-	ns
3	PCM bit clock Low	41	-	-	ns
4	PCM_SYNC delay	0	-	25	ns
5	PCM_OUT delay	0	-	25	ns
6	PCM_IN setup	8	-	-	ns
7	PCM_IN hold	8	-	-	ns
8	Delay from rising edge of PCM_BCLK during last bit period to PCM_OUT becoming high impedance	0	-	25	ns

10.7. Short Frame Sync, Slave Mode

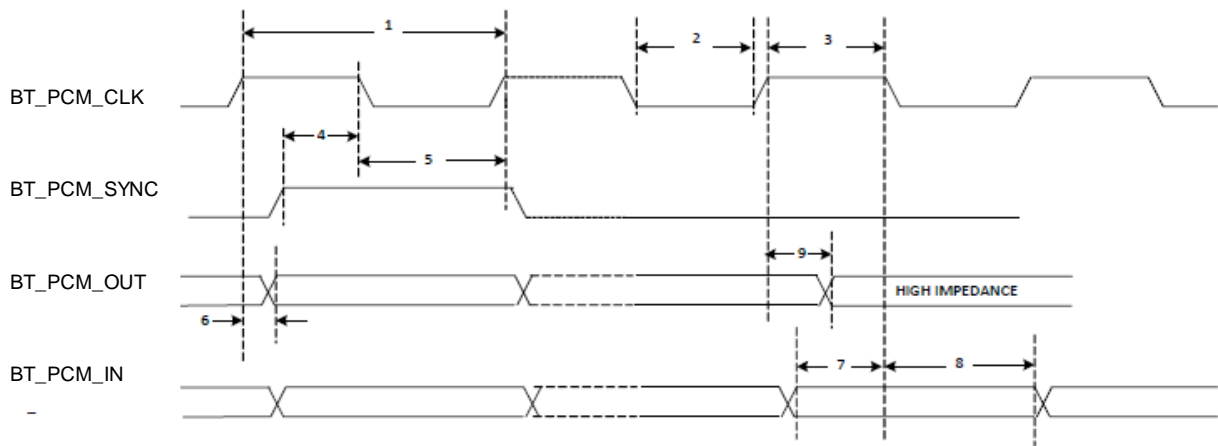

Reference	Description	Min	Typ	Max	Unit
1	PCM bit clock frequency	-	-	12	MHz
2	PCM bit clock Low	41	-	-	ns
3	PCM bit clock High	41	-	-	ns
4	PCM_SYNC setup	8	-	-	ns
5	PCM_SYNC hold	8	-	-	Ns
6	PCM_OUT delay	0	-	25	Ns
7	PCM_IN setup	8	-	-	Ns
8	PCM_IN hold	8	-	-	Ns
9	Delay from rising edge of PCM_BCLK during last bit period to PCM_OUT becoming high impedance	0	-	25	Ns

10.8. Long Frame Sync, Master Mode

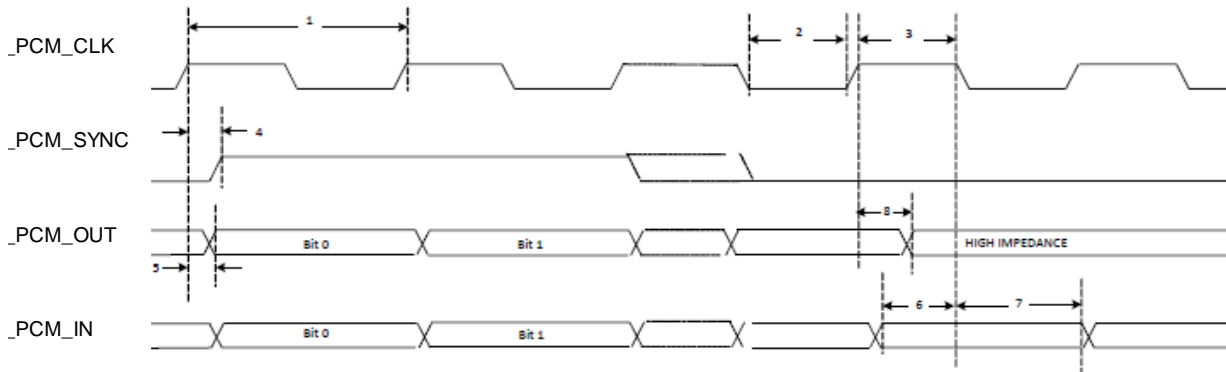

Reference	Description	Min	Typ	Max	Unit
1	PCM bit clock frequency	-	-	12	MHz
2	PCM bit clock High	41	-	-	ns
3	PCM bit clock Low	41	-	-	ns
4	PCM_SYNC delay	0	-	25	ns
5	PCM_OUT delay	0	-	25	ns
6	PCM_IN setup	8	-	-	ns
7	PCM_IN hold	8	-	-	ns
8	Delay from rising edge of PCM_BCLK during last bit period to PCM_OUT becoming high impedance	0	-	25	ns

10.9. Long Frame Sync, Slave Mode

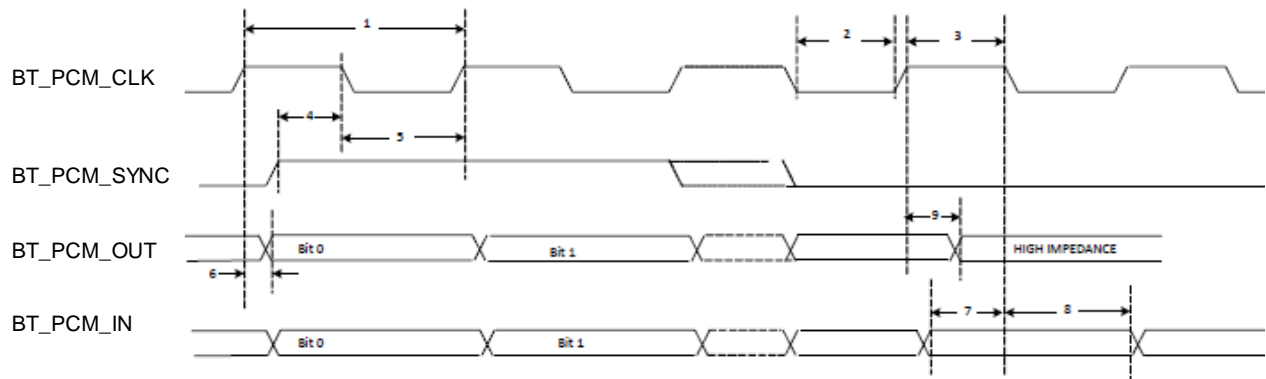

Reference	Description	Min	Typ	Max	Unit
1	PCM bit clock frequency	-	-	12	MHz
2	PCM bit clock High	41	-	-	ns
3	PCM bit clock Low	41	-	-	ns
4	PCM_SYNC setup	8	-	-	ns
5	PCM_SYNC hold	8	-	-	ns
6	PCM_OUT delay	0	-	25	ns
7	PCM_IN setup	8	-	-	ns
8	PCM_IN hold	8	-	-	ns
9	Delay from rising edge of PCM_BCLK during last bit period to PCM_OUT becoming high impedance	0	-	25	ns

10.9.1. Short Frame Sync, Burst Mode

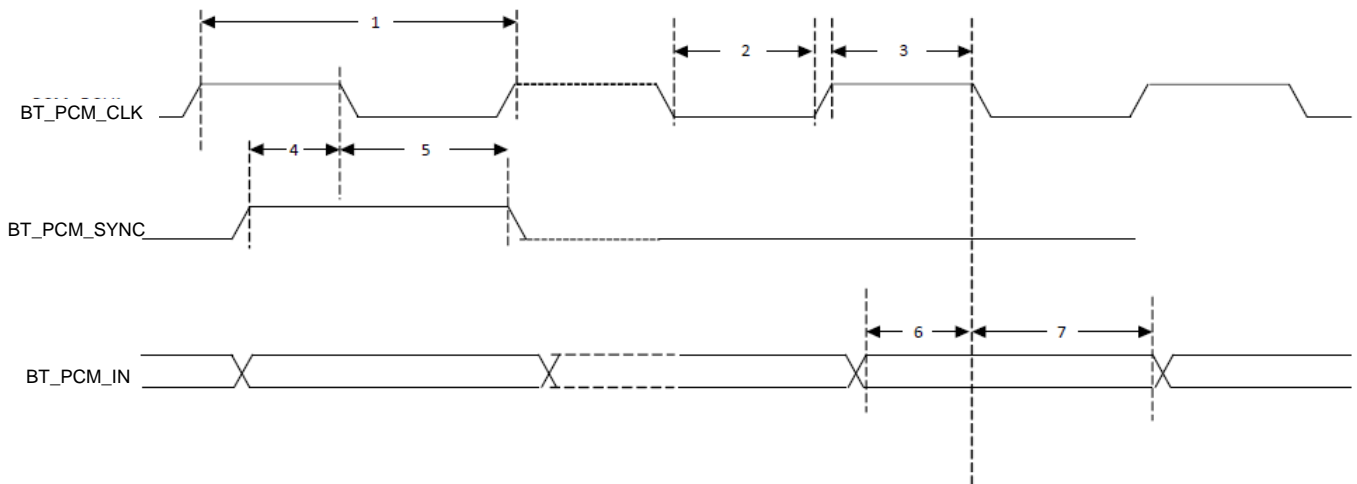

Reference	Description	Min	Typ	Max	Unit
1	PCM bit clock frequency	-	-	24	MHz
2	PCM bit clock Low	20.8	-	-	ns
3	PCM bit clock High	20.8	-	-	ns
4	PCM_SYNC setup	8	-	-	ns
5	PCM_SYNC hold	8	-	-	ns
6	PCM_IN setup	8	-	-	ns
7	PCM_IN hold	8	-	-	ns

10.9.2. Long Frame Sync, Burst Mode

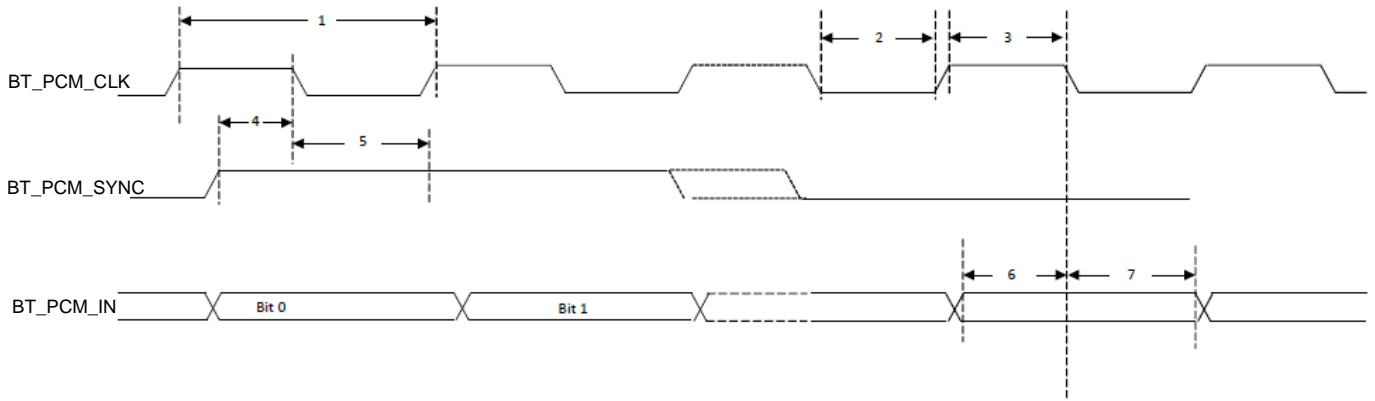

Reference	Description	Min	Typ	Max	Unit
1	PCM bit clock frequency	-	-	24	MHz
2	PCM bit clock Low	20.8	-	-	ns
3	PCM bit clock High	20.8	-	-	ns
4	PCM_SYNC setup	8	-	-	ns
5	PCM_SYNC hold	8	-	-	ns
6	PCM_IN setup	8	-	-	ns
7	PCM_IN hold	8	-	-	ns

11. DC / RF Characteristics

ALL DC/RF characteristics are defined by following file.

WLAN:nvram file	cyfmac4373-sdio.txt
BT:hcd file	4373A0_Generic_UART_37_4MHz_wlbgA_BU_sLNA_202107091730_0x800.hcd

11.1. DC/RF Characteristics for IEEE802.11b - 2.4GHz

Specification	IEEE802.11b
Mode	DSSS / CCK
Channel Frequency	2412 - 2472MHz
Data rate	1, 2, 5.5, 11Mbps

11.1.1. High Rate Condition for IEEE802.11b – 2.4GHz

Conditions : 25deg.C, VBAT=3.3V, VDDIO= 3.3V, Output power setting=17dBm, 11Mbps mode

Items	Contents			
	Min.	Typ.	Max.	Unit
- DC Characteristics -				
1. DC current				
1) Tx mode (1024byte, 20usec interval) *1		350		mA
2) Rx mode		40		mA
- Tx Characteristics *1-				
	Min.	Typ.	Max.	Unit
2. Output Power	14.5	17	19.5	dBm
3. Spectrum Mask margin				
1) 1st side lobes(-30dBr)	0		-	dB
2) 2nd side lobes(-50dBr)	0		-	dB
4. Power-on and Power-down ramp	-		2.0	μsec
5. RF Carrier Suppression	15	-	-	dB
6. Modulation Accuracy (EVM)	-		35	%
7. Frequency tolerance	-20		20	ppm
8. Out band Spurious Emissions				
1) 30MHz to 1GHz (BW=100kHz)	-	-	-36	dBm
annotation				
47MHz to 74MHz(BW=100kHz)				
87.5MHz to 118MHz(BW=100kHz)	-	-	-54	dBm
174MHz to 230MHz(BW=100kHz)				
470MHz to 862MHz(BW=100kHz)				
2) 1GHz to 12.75GHz (BW=1MHz)	-	-	-30	dBm
- Rx Characteristics -				
	Min.	Typ.	Max.	Unit
9. Minimum Input Level Sensitivity	-		-76	dBm
10. Maximum Input Level (FER < 8%)	-10	-	-	dBm
11. Adjacent Channel Rejection (FER ≤ 8%)	35	-	-	dB

*1: Defined when output power setting is 17dBm at Murata module antenna pad

11.1.2. Low Rate Condition for IEEE802.11b – 2.4GHz

Conditions : 25deg.C, VBAT=3.3V, VDDIO= 3.3V, Output power setting=17dBm, 1Mbps mode

Items	Contents			
	Min.	Typ.	Max.	Unit
- DC Characteristics -				
1. DC current				
1) Tx mode (1024byte, 20usec interval) *2		340		mA
2) Rx mode		40		mA
- Tx Characteristics *2-				
	Min.	Typ.	Max.	Unit
2. Output Power	14.5	17	19.5	dBm
3. Spectrum Mask margin				
1) 1st side lobes(-30dBr)	0		-	dB
2) 2nd side lobes(-50dBr)	0		-	dB
4. Power-on and Power-down ramp	-		2.0	μsec
5. RF Carrier Suppression	15		-	dB
6. Modulation Accuracy (EVM)	-		35	%
7. Frequency tolerance	-20		20	ppm
8. Out band Spurious Emissions				
1) 30MHz to 1GHz (BW=100kHz)	-	-	-36	dBm
annotation				
47MHz to 74MHz(BW=100kHz)				
87.5MHz to 118MHz(BW=100kHz)	-	-	-54	dBm
174MHz to 230MHz(BW=100kHz)				
470MHz to 862MHz(BW=100kHz)				
2) 1GHz to 12.75GHz (BW=1MHz)	-	-	-30	dBm
- Rx Characteristics -				
	Min.	Typ.	Max.	Unit
9. Minimum Input Level Sensitivity	-		-76	dBm
10. Maximum Input Level (FER ≤ 8%)	-10	-	-	dBm
11. Adjacent Channel Rejection (FER ≤ 8%)	35	-	-	dB

*2: Defined when output power setting is 17dBm at Murata module antenna pad

11.2. DC/RF Characteristics for IEEE802.11g - 2.4GHz

Specification	IEEE802.11g
Mode	OFDM
Channel Frequency	2412 - 2472MHz
Data rate	6, 9, 12, 18, 24, 36, 48, 54Mbps

11.2.1. High Rate Condition for IEEE802.11g – 2.4GHz

Conditions : 25deg.C, VBAT=3.3V, VDDIO= 3.3V, Output power setting=16dBm, 54Mbps mode

Items	Contents			
	Min.	Typ.	Max.	Unit
- DC Characteristics -				
1. DC current				
1) Tx mode (1024byte, 20usec interval) *3		290		mA
2) Rx mode		40		mA
- Tx Characteristics*3 -				
	Min.	Typ.	Max.	Unit
2. Output Power	13.5	16	18.5	dBm
3. Spectrum Mask margin				
1) 9MHz to 11MHz (0~ -20dBr)	0		-	dB
2) 11MHz to 20MHz (-20~ -28dBr)	0		-	dB
3) 20MHz to 30MHz (-28~ -40dBr)	0		-	dB
4) 30MHz to 33MHz (-40dBr)	0		-	dB
4. Constellation Error (EVM)	-		-25	dB
5. Frequency tolerance	-20		20	ppm
6. Out band Spurious Emissions				
1) 30MHz to 1GHz (BW=100kHz)	-	-	-36	dBm
annotation				
47MHz to 74MHz(BW=100kHz)				
87.5MHz to 118MHz(BW=100kHz)	-	-	-54	dBm
174MHz to 230MHz(BW=100kHz)				
470MHz to 862MHz(BW=100kHz)				
2) 1GHz to 12.75GHz (BW=1MHz)	-	-	-30	dBm
- Rx Characteristics -				
	Min.	Typ.	Max.	Unit
7. Minimum Input Level Sensitivity	-		-65	dBm
8. Maximum Input Level (PER ≤ 10%)	-20	-	-	dBm
9. Adjacent Channel Rejection (PER ≤ 10%)	-1	-	-	dB

*3: Defined when output power setting is 16dBm at Murata module antenna pad

11.2.2. Low Rate Condition for IEEE802.11g – 2.4GHz

Conditions : 25deg.C, VBAT=3.3V, VDDIO= 3.3V, Output power setting=18dBm, 6Mbps mode

Items	Contents			
	Min.	Typ.	Max.	unit
- DC Characteristics -				
1. DC current				
1) Tx mode (1024byte, 20usec interval) *4		310		mA
2) Rx mode		40		mA
- Tx Characteristics*4 -				
	Min.	Typ.	Max.	unit
2. Output Power	15.5	18	20.5	dBm
3. Spectrum Mask margin				
1) 9MHz to 11MHz (0~ -20dBr)	0	-	-	dB
2) 11MHz to 20MHz (-20~ -28dBr)	0	-	-	dB
3) 20MHz to 30MHz (-28~ -40dBr)	0	-	-	dB
4) 30MHz to 33MHz (-40dBr)	0	-	-	dB
4. Constellation Error (EVM)	-	-	-5	dB
5. Frequency tolerance	-20		20	ppm
6. Out band Spurious Emissions				
1) 30MHz to 1GHz (BW=100kHz)	-	-	-36	dBm
annotation				
47MHz to 74MHz(BW=100kHz)				
87.5MHz to 118MHz(BW=100kHz)	-	-	-54	dBm
174MHz to 230MHz(BW=100kHz)				
470MHz to 862MHz(BW=100kHz)				
2) 1GHz to 12.75GHz (BW=1MHz)	-	-	-30	dBm
- Rx Characteristics -				
	Min.	Typ.	Max.	unit
7. Minimum Input Level Sensitivity	-	-	-82	dBm
8. Maximum Input Level (PER ≤ 10%)	-20	-	-	dBm
9. Adjacent Channel Rejection (PER ≤ 10%)	16	-	-	dB

*4: Defined when output power setting is 18dBm at Murata module antenna pad

11.3. DC/RF Characteristics for IEEE802.11n – 2.4GHz

Specification	IEEE802.11n
Mode	OFDM
Channel Frequency	2412 - 2472MHz
Data rate	MCS0-MCS7

11.3.1. High Rate Condition for IEEE802.11n – 2.4GHz

Conditions : 25deg.C, VBAT=3.3V, VDDIO= 3.3V, Output power setting=14dBm, MCS7

Items	Contents			
	Min.	Typ.	Max.	unit
- DC Characteristics -				
1. DC current				
1) Tx mode (1024byte, 20usec interval) *5		280		mA
2) Rx mode		40		mA
- Tx Characteristics*5 -	Min.	Typ.	Max.	unit
2. Output Power	11.5	14	16.5	dBm
3. Spectrum Mask				
1) 9MHz to 11MHz (0 ~ -20dBr)	0		-	dB
2) 11MHz to 20MHz (-20 ~ -28dBr)	0		-	dB
3) 20MHz to 30MHz (-28 ~ -45dBr)	0		-	dB
4) 30MHz to 33MHz (-45dBr)	0		-	dB
4. Constellation Error (EVM)	-		-27	dB
5. Frequency tolerance	-20		20	ppm
6. Out band Spurious Emissions				
1) 30MHz to 1GHz (BW=100kHz)	-	-	-36	dBm
annotation				
47MHz to 74MHz(BW=100kHz)				
87.5MHz to 118MHz(BW=100kHz)	-	-	-54	dBm
174MHz to 230MHz(BW=100kHz)				
470MHz to 862MHz(BW=100kHz)				
2) 1GHz to 12.75GHz (BW=1MHz)	-	-	-30	dBm
- Rx Characteristics -	Min.	Typ.	Max.	unit
6. Minimum Input Level Sensitivity	-		-64	dBm
7. Adjacent Channel Rejection (PER ≤ 10%)	-2	-	-	dB

*5: Defined when output power setting is 14dBm at Murata module antenna pad

11.3.2. Low Rate Condition for IEEE802.11n – 2.4GHz

Conditions : 25deg.C, VBAT=3.3V, VDDIO= 3.3V, Output power setting=16dBm, MCS0

Items	Contents			
	Min.	Typ.	Max.	unit
- DC Characteristics -				
1. DC current				
1) Tx mode (1024byte, 20usec interval) *6		300		mA
2) Rx mode		40		mA
- Tx Characteristics*6 -				
	Min.	Typ.	Max.	unit
2. Output Power	13.5	16	18.5	dBm
3. Spectrum Mask				
1) 9MHz to 11MHz (0 ~ -20dBr)	0		-	dB
2) 11MHz to 20MHz (-20 ~ -28dBr)	0		-	dB
3) 20MHz to 30MHz (-28 ~ -45dBr)	0		-	dB
4) 30MHz to 33MHz (-45dBr)	0		-	dB
4. Constellation Error (EVM)	-		-5	dB
5. Frequency tolerance	-20		20	ppm
6. Out band Spurious Emissions				
1) 30MHz to 1GHz (BW=100kHz)	-	-	-36	dBm
annotation				
47MHz to 74MHz(BW=100kHz)				
87.5MHz to 118MHz(BW=100kHz)	-	-	-54	dBm
174MHz to 230MHz(BW=100kHz)				
470MHz to 862MHz(BW=100kHz)				
2) 1GHz to 12.75GHz (BW=1MHz)	-	-	-30	dBm
- Rx Characteristics -				
	Min.	Typ.	Max.	unit
6. Minimum Input Level Sensitivity	-		-82	dBm
7. Adjacent Channel Rejection (PER ≤ 10%)	16	-	-	dB

*6: Defined when output power setting is 16dBm at Murata module antenna pad

11.4. DC/RF Characteristics for IEEE802.11a - 5GHz

Specification	IEEE802.11a
Mode	OFDM
Channel Frequency	5180 to 5240MHz, 5260 to 5320MHz, 5500 to 5720MHz, 5745 to 5825MHz
Data rate	6, 9, 12, 18, 24, 36, 48, 54Mbps

11.4.1. High Rate Condition for IEEE802.11a – 5GHz

Conditions : 25deg.C, VBAT=3.3V, VDDIO= 3.3V, Output power setting=14dBm, 54Mbps

Items	Contents			
	Min.	Typ.	Max.	unit
- DC Characteristics -				
1. DC current				
1) Tx mode (1024byte, 20usec interval) *7		290		mA
2) Rx mode		60		mA
- Tx Characteristics*7 -				
	Min.	Typ.	Max.	unit
2. Output Power	12	14	16	dBm
3. Spectrum Mask				
1) 9MHz to 11MHz (0~ -20dBr)	0		-	dB
2) 11MHz to 20MHz (-20~ -28dBr)	0		-	dB
3) 20MHz to 30MHz (-28~ -40dBr)	0		-	dB
4) 30MHz to 33MHz (-40dBr)	0		-	dB
4. Constellation Error (EVM)	-		-25	dB
5. Frequency tolerance	-20		20	ppm
- Rx Characteristics -				
	Min.	Typ.	Max.	unit
6. Minimum Input Level Sensitivity	-	.	-65	dBm
7. Adjacent Channel Rejection (PER ≤ 10%)	-1	-	-	dB

*7: Defined when output power setting is 14dBm at Murata module antenna pad

11.4.2. Low Rate Condition for IEEE802.11a – 5GHz

Conditions : 25deg.C, VBAT=3.3V, VDDIO= 3.3V, Output power setting=16dBm, 6Mbps

Items	Contents			
	Min.	Typ.	Max.	unit
- DC Characteristics -				
1. DC current				
1) Tx mode (1024byte, 20usec interval) *8		310		mA
2) Rx mode		60		mA
- Tx Characteristics*8 -				
2. Output Power	14	16	18	dBm
3. Spectrum Mask				
1) 9MHz to 11MHz (0~ -20dBr)	0		-	dB
2) 11MHz to 20MHz (-20~ -28dBr)	0		-	dB
3) 20MHz to 30MHz (-28~ -40dBr)	0		-	dB
4) 30MHz to 33MHz (-40dBr)	0		-	dB
4. Constellation Error (EVM)	-		-5	dB
5. Frequency tolerance	-20		20	ppm
- Rx Characteristics -				
6. Minimum Input Level Sensitivity	-		-82	dBm
7. Adjacent Channel Rejection (PER ≤ 10%)	16	-	-	dB

*8: Defined when output power setting is 16dBm at Murata module antenna pad

11.5. DC/RF Characteristics for IEEE802.11n(HT20) - 5GHz

Specification	IEEE802.11n
Mode	OFDM
Frequency	5180 - 5825MHz
Data rate	MCS0-MCS7

11.5.1. High Rate Condition for IEEE802.11n(HT20) – 5GHz

Conditions : 25deg.C, VBAT=3.3V, VDDIO= 3.3V, Output power setting=14dBm, MCS7

Items	Contents			
	Min.	Typ.	Max.	unit
- DC Characteristics -				
1. DC current				
1) Tx mode (1024byte, 20usec interval) *9		280		mA
2) Rx mode		70		mA
- Tx Characteristics*9 -				
2. Output Power	12	14	16	dBm
3. Spectrum Mask				
1) 9MHz to 11MHz (0~ -20dBr)	0		-	dB
2) 11MHz to 20MHz (-20~ -28dBr)	0		-	dB
3) 20MHz to 30MHz (-28~ -40dBr)	0		-	dB
4) 30MHz to 33MHz (-40dBr)	0		-	dB
4. Constellation Error (EVM)	-		-27	dB
5. Frequency tolerance	-20		20	ppm
- Rx Characteristics -				
6. Minimum Input Level Sensitivity	-		-64	dBm
7. Adjacent Channel Rejection (PER ≤ 10%)	-2	-	-	dB

*9: Defined when output power setting is 14dBm at Murata module antenna pad

11.5.2. Low Rate Condition for IEEE802.11n(HT20) – 5GHz

Conditions : 25deg.C, VBAT=3.3V, VDDIO= 3.3V, Output power setting=16dBm, MCS0

Items	Contents			
	Min.	Typ.	Max.	unit
- DC Characteristics -				
1. DC current				
1) Tx mode (1024byte, 20usec interval) *10		300		mA
2) Rx mode		60		mA
- Tx Characteristics*10 -				
	Min.	Typ.	Max.	unit
2. Output Power	14	16	18	dBm
3. Spectrum Mask				
1) 9MHz to 11MHz (0~ -20dBr)	0		-	dB
2) 11MHz to 20MHz (-20~ -28dBr)	0		-	dB
3) 20MHz to 30MHz (-28~ -40dBr)	0		-	dB
4) 30MHz to 33MHz (-40dBr)	0		-	dB
4. Constellation Error (EVM)	-		-5	dB
5. Frequency tolerance	-20		20	ppm
- Rx Characteristics -				
	Min.	Typ.	Max.	unit
6. Minimum Input Level Sensitivity	-		-82	dBm
7. Adjacent Channel Rejection (PER ≤ 10%)	16	-	-	dB

*10: Defined when output power setting is 16dBm at Murata module antenna pad

11.6. DC/RF Characteristics for IEEE802.11ac(HT20) - 5GHz

Specification	IEEE802.11ac
Mode	OFDM
Frequency	5180 - 5825MHz
Data rate	MCS0-MCS8

11.6.1. High Rate Condition for IEEE802.11ac(VHT20) – 5GHz

Conditions : 25deg.C, VBAT=3.3V, VDDIO= 3.3V, Output power setting=13dBm, MCS8

Items	Contents			
	Min.	Typ.	Max.	unit
- DC Characteristics -				
1. DC current				
1) Tx mode (1024byte, 20usec interval) *11		280		mA
2) Rx mode		60		mA
- Tx Characteristics*11 -				
	Min.	Typ.	Max.	unit
2. Output Power	11	13	15	dBm
3. Spectrum Mask				
1) 9MHz to 11MHz (0~ -20dBr)	0		-	dB
2) 11MHz to 20MHz (-20~ -28dBr)	0		-	dB
3) 20MHz to 30MHz (-28~ -40dBr)	0		-	dB
4) 30MHz to 33MHz (-40dBr)	0		-	dB
4. Constellation Error (EVM)	-		-30	dB
5. Frequency tolerance	-20		20	ppm
- Rx Characteristics -				
	Min.	Typ.	Max.	unit
6. Minimum Input Level Sensitivity	-		-59	dBm
7. Adjacent Channel Rejection (PER ≤ 10%)	-7	-	-	dB

*11: Defined when output power setting is 13dBm at Murata module antenna pad

11.6.2. Low Rate Condition for IEEE802.11ac(VHT20) – 5GHz

Conditions : 25deg.C, VBAT=3.3V, VDDIO= 3.3V, Output power setting=16dBm, MCS0

Items	Contents			
	Min.	Typ.	Max.	unit
- DC Characteristics -				
1. DC current				
1) Tx mode (1024byte, 20usec interval) *12		300		mA
2) Rx mode		60		mA
- Tx Characteristics*12 -				
2. Output Power	14	16	18	dBm
3. Spectrum Mask				
1) 9MHz to 11MHz (0~ -20dBr)	0		-	dB
2) 11MHz to 20MHz (-20~ -28dBr)	0		-	dB
3) 20MHz to 30MHz (-28~ -40dBr)	0		-	dB
4) 30MHz to 33MHz (-40dBr)	0		-	dB
4. Constellation Error (EVM)	-		-5	dB
5. Frequency tolerance	-20		20	ppm
- Rx Characteristics -				
6. Minimum Input Level Sensitivity	-		-82	dBm
7. Adjacent Channel Rejection (PER ≤ 10%)	16	-	-	dB

*12: Defined when output power setting is 16dBm at Murata module antenna pad

11.7. DC/RF Characteristics for IEEE802.11n(HT 40MHz) - 5GHz

Specification	IEEE802.11n
Mode	OFDM
Channel Frequency	5190 to 5795MHz
Data rate	MCS0-MCS7

11.7.1. High Rate Condition for IEEE802.11n(HT40) – 5GHz

Conditions : 25deg.C, VBAT=3.3V, VDDIO= 3.3V, Output power setting=13dBm, MCS7, HT 40MHz

Items	Contents			
	Min.	Typ.	Max.	unit
- DC Characteristics -				
1. DC current				
1) Tx mode (1024byte, 20usec interval) *13		320		mA
2) Rx mode		70		mA
- Tx Characteristics*13 -				
2. Output Power	11	13	15	dBm
3. Spectrum Mask margin				
1) 19MHz to 21MHz (0~ -20dBr)	0		-	dB
2) 21MHz to 40MHz (-20~ -28dBr)	0		-	dB
3) 40MHz to 60MHz (-28~ -45dBr)	0		-	dB
4) 60MHz to 80MHz (-45dBr)	0		-	dB
4. Constellation Error (EVM)	-		-27	dB
5. Frequency tolerance	-20		20	ppm
- Rx Characteristics -				
6. Minimum Input Level Sensitivity	-		-61	dBm
7. Adjacent Channel Rejection (PER ≤ 10%)	-2	-	-	dB

*13: Defined when output power setting is 13dBm at Murata module antenna pad

11.7.2. Low Rate Condition for IEEE802.11n(HT40) – 5GHz

Conditions : 25deg.C, VBAT=3.3V, VDDIO= 3.3V, Output power setting=14dBm, MCS0, HT 40MHz

Items	Contents			
	Min.	Typ.	Max.	unit
- DC Characteristics -				
1. DC current				
1) Tx mode (1024byte, 20usec interval) *14		350		mA
2) Rx mode		70		mA
- Tx Characteristics*14 -				
	Min.	Typ.	Max.	unit
2. Output Power	12	14	16	dBm
3. Spectrum Mask margin				
1) 19MHz to 21MHz (0~ -20dBr)	0		-	dB
2) 21MHz to 40MHz (-20~ -28dBr)	0		-	dB
3) 40MHz to 60MHz (-28~ -45dBr)	0		-	dB
4) 60MHz to 80MHz (-45dBr)	0		-	dB
4. Constellation Error (EVM)	-		-5	dB
5. Frequency tolerance	-20		20	ppm
- Rx Characteristics -				
	Min.	Typ.	Max.	unit
6. Minimum Input Level Sensitivity	-		-79	dBm
7. Adjacent Channel Rejection (PER ≤ 10%)	16	-	-	dB

*14: Defined when output power setting is 14dBm at Murata module antenna pad

11.8. DC/RF Characteristics for IEEE802.11ac(VHT 40MHz) - 5GHz

Specification	IEEE802.11ac
Mode	OFDM
Channel Frequency	5190 to 5795MHz
Data rate	MCS0-MCS9

11.8.1. High Rate Condition for IEEE802.11ac(VHT40) – 5GHz

Conditions : 25deg.C, VBAT=3.3V, VDDIO= 3.3V, Output power setting=11dBm, MCS9, VHT 40MHz

Items	Contents			
	Min.	Typ.	Max.	unit
- DC Characteristics -				
1. DC current				
1) Tx mode (1024byte, 20usec interval) *15		320		mA
2) Rx mode		70		mA
- Tx Characteristics*15 -				
	Min.	Typ.	Max.	unit
2. Output Power	9	11	13	dBm
3. Spectrum Mask margin				
1) 19MHz to 21MHz (0~ -20dBr)	0		-	dB
2) 21MHz to 40MHz (-20~ -28dBr)	0		-	dB
3) 40MHz to 60MHz (-28~ -45dBr)	0		-	dB
4) 60MHz to 80MHz (-45dBr)	0		-	dB
4. Constellation Error (EVM)	-		-32	dB
5. Frequency tolerance	-20		20	ppm
- Rx Characteristics -				
	Min.	Typ.	Max.	unit
6. Minimum Input Level Sensitivity	-		-54	dBm
7. Adjacent Channel Rejection (PER ≤ 10%)	-9	-	-	dB

*15: Defined when output power setting is 11dBm at Murata module antenna pad

11.8.2. Low Rate Condition for IEEE802.11ac(VHT40) – 5GHz

Conditions : 25deg.C, VBAT=3.3V, VDDIO= 3.3V, Output power setting=14dBm, MCS0, VHT 40MHz

Items	Contents			
	Min.	Typ.	Max.	unit
- DC Characteristics -				
1. DC current				
1) Tx mode (1024byte, 20usec interval) *16		350		mA
2) Rx mode		70		mA
- Tx Characteristics*16 -				
	Min.	Typ.	Max.	unit
2. Output Power	12	14	16	dBm
3. Spectrum Mask margin				
1) 19MHz to 21MHz (0~ -20dBr)	0		-	dB
2) 21MHz to 40MHz (-20~ -28dBr)	0		-	dB
3) 40MHz to 60MHz (-28~ -45dBr)	0		-	dB
4) 60MHz to 80MHz (-45dBr)	0		-	dB
4. Constellation Error (EVM)	-		-5	dB
5. Frequency tolerance	-20		20	ppm
- Rx Characteristics -				
	Min.	Typ.	Max.	unit
6. Minimum Input Level Sensitivity	-		-54	dBm
7. Adjacent Channel Rejection (PER ≤ 10%)	16	-	-	dB

*16: Defined when output power setting is 14dBm at Murata module antenna pad

11.9. DC/RF Characteristics for IEEE802.11ac(VHT 80MHz) - 5GHz

Specification	IEEE802.11ac
Mode	OFDM
Channel Frequency	5210MHz to 5775MHz
Data rate	MCS0-MCS9

11.9.1. High Rate Condition for IEEE802.11ac(VHT80) – 5GHz

Conditions : 25deg.C, VBAT=3.3V, VDDIO= 3.3V, Output power setting=11dBm, MCS9,VHT 80MHz

Items	Contents			
	Min.	Typ.	Max.	unit
- DC Characteristics -				
1. DC current				
1) Tx mode (1024byte, 20usec interval) *17		340		mA
2) Rx mode		90		mA
- Tx Characteristics*17 -				
	Min.	Typ.	Max.	unit
2. Output Power	9	11	13	dBm
3. Spectrum Mask margin				
1) 39MHz to 41MHz (0~ -20dBr)	0			dB
2) 41MHz to 80MHz (-20~ -28dBr)	0			dB
3) 80MHz to 120MHz (-28~ -40dBr)	0			dB
4) 120MHz to 140MHz (-40dBr)	0			dB
4. Constellation Error	-		-32	dB
5. Frequency tolerance	-20		20	ppm
- Rx Characteristics -				
	Min.	Typ.	Max.	unit
6. Minimum Input Level Sensitivity	-		-51	dBm
7. Adjacent Channel Rejection (PER ≤ 10%)	-9	-	-	dB

*17: Defined when output power setting is 11dBm at Murata module antenna pad

11.9.2. Low Rate Condition for IEEE802.11ac(VHT80) – 5GHz

Conditions : 25deg.C, VBAT=3.3V, VDDIO= 3.3V, Output power setting=13dBm, MCS0,VHT 80MHz

Items	Contents			
	Min.	Typ.	Max.	unit
- DC Characteristics -				
1. DC current				
1) Tx mode (1024byte, 20usec interval) *18		380		mA
2) Rx mode		90		mA
- Tx Characteristics*18 -				
	Min.	Typ.	Max.	unit
2. Output Power	11	13	15	dBm
3. Spectrum Mask margin				
1) 39MHz to 41MHz (0~ -20dBr)	0			dB
2) 41MHz to 80MHz (-20~ -28dBr)	0			dB
3) 80MHz to 120MHz (-28~ -40dBr)	0			dB
4) 120MHz to 140MHz (-40dBr)	0			dB
4. Constellation Error	-		-5	dB
5. Frequency tolerance	-20		20	ppm
- Rx Characteristics -				
	Min.	Typ.	Max.	unit
6. Minimum Input Level Sensitivity	-		-76	dBm
7. Adjacent Channel Rejection (PER ≤ 10%)	16	-	-	dB

*18: Defined when output power setting is 13dBm at Murata module antenna pad

11.10. DC/RF Characteristics for Bluetooth®

Conditions : 25deg.C, VBAT=3.3V, VDDIO= 3.3V

Items	Contents			
Bluetooth® specification (power class)	Version 5.2			
Channel frequency (spacing)	2402 to 2480 MHz (1MHz)			
Current Consumption	Min.	Typ.	Max.	unit
(a) Tx=Rx=DH5 (fully occupied)	-	55		mA
(b) Tx=Rx=2DH5 (fully occupied)	-	45		mA
(c) Tx=Rx=3DH5 (fully occupied)	-	45		mA
Transmitter	Min.	Typ.	Max.	Unit
Output Power@DH5	6	10	14	dBm
Frequency range	2400	-	2483.5	MHz
20dB bandwidth	-		1	MHz
Adjacent Channel Power *1				
(a) [M-N] =2	-	-	-20	dBm
(b) [M-N] ≥3	-	-	-40	dBm
Modulation characteristics				
(a) Modulation Δf1avg	140		175	kHz
(b) Modulation Δf2max	115		-	kHz
(c) Modulation Δf2avg / Δf1avg	0.8	1	-	
Carrier Frequency Drift				
(a) 1slot	-25	-	25	kHz
(b) 3slot / 5slot	-40	-	40	kHz
(c) Maximum drift rate		-	20	kHz/50us
EDR Relative Power	-4	-	1	dB
EDR Carrier Frequency Stability and Modulation Accuracy				
(a) ωi	-75	-	75	kHz
(b) ωi+ωo	-75	-	75	kHz
(c) ωo	-10	-	10	kHz
(d) RMS DEVM (DQPSK)	-	-	20	%
(e) Peak DEVM (DQPSK)	-	-	35	%
(f) 99% DEVM (DQPSK)	-	-	30	%
(g) RMS DEVM (8DPSK)	-	-	13	%
(h) Peak DEVM (8DPSK)	-	-	25	%
(i) 99% DEVM (8DPSK)	-	-	20	%
Spurious Emissions				
(a) 30MHz to 1GHz (BW=100kHz)	-	-	-36	dBm
annotation 47MHz to 74MHz(BW=100kHz) 87.5MHz to 118MHz(BW=100kHz) 174MHz to 230MHz(BW=100kHz) 470MHz to 862MHz(BW=100kHz)	-	-	-54	dBm
(b) 1GHz to 12.75GHz (BW=1MHz)	-	-	-30	dBm
Receiver	Min.	Typ.	Max.	unit
BDR Sensitivity (BER≤0.1%)	-	-	-80	dBm
EDR Sensitivity (BER≤0.007%)@8DPSK	-	-	-77	dBm
C/I Performance (BER≤0.1%) *2				
(a) co-channel	-	-	11	dB
(b) 1MHz	-	-	0	dB
(c) 2MHz	-	-	-30	dB
(d) 3MHz	-	-	-40	dB
(e) image (+4MHz)	-	-	-9	dB
(f) image +/- 1MHz	-	-	-20	dB
Maximum Input Level (BER≤0.1%)	-20	-	-	dBm

*1: Up to three spurious responses within Bluetooth® limits are allowed.

*2: Up to five spurious responses within Bluetooth® limits are allowed.

11.11. DC/RF Characteristics for Bluetooth® (LE)

Conditions : 25deg.C, VBAT=3.3V, VDDIO= 3.3V

Items	Contents			
Bluetooth® specification (power class)	Version 5.2(LE)			
Channel frequency (spacing)	2402 to 2480 MHz (2MHz)			
Number of RF Channel	40			
Item / Condition	Min.	Typ.	Max.	Unit
Center Frequency	2402	-	2480	MHz
Channel Spacing	-	2	-	MHz
Number of RF channel	-	40	-	-
Output power	-	8	-	dBm
Modulation Characteristics				
1) Δf_{1avg}	225	-	275	kHz
2) Δf_{2max} (at 99.9%)	185	-	-	kHz
3) $\Delta f_{2avg} / \Delta f_{1avg}$	0.8	-	-	-
Carrier frequency offset and drift				
1) Frequency offset	-	-	150	kHz
2) Frequency drift	-	-	50	kHz
3) Drift rate	-	-	20	kHz
Receiver sensitivity (PER < 30.8%)	-	-	-70	dBm
Maximum input signal level (PER < 30.8%)	-10	-	-	dBm
PER Report Integrity (-30dBm input)	50	-	65.4	%

13. Reference Circuit Module

- 1.VBAT typical value is 3.3 +/-5% V
- 2.VDDIO can be provide 1.8V or 3.3V
- 3.LPO_IN must be provide.
- 4.JTAG_SEL must be kept connect to ground if the JTAG interface is not used. It must be high to select SWD OR JTAG

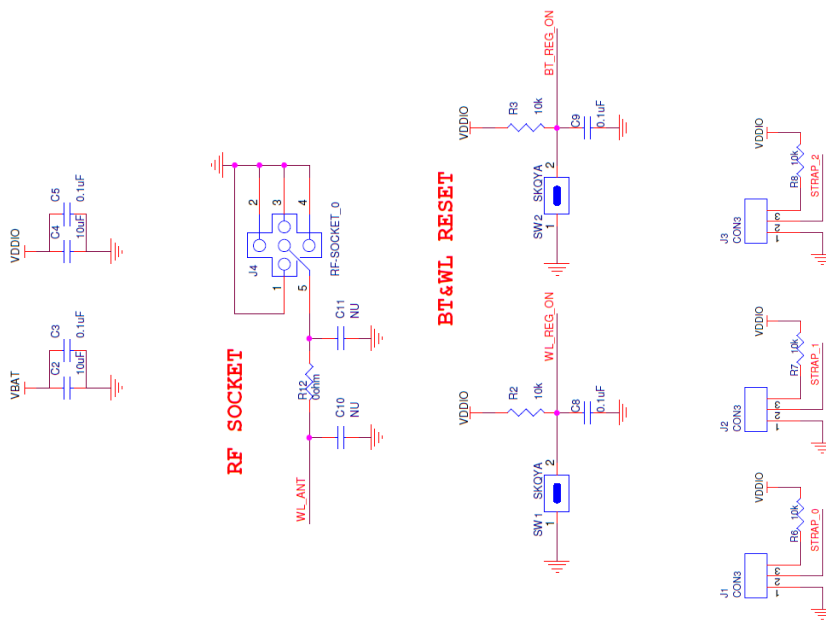

Strapping options

Mode Selected	Strap_2	Strap_1	Strap_0	J17	J16	J15
SDIO 3.3V	1	0	0	Jump on pin2,3	Jump on pin1,2	Jump on pin1,2
SDIO 1.8V	1	0	0	Jump on pin2,3	Jump on pin1,2	Jump on pin2,3
USB	0	0	1	Jump on pin1,2	Jump on pin1,2	Jump on pin1,2

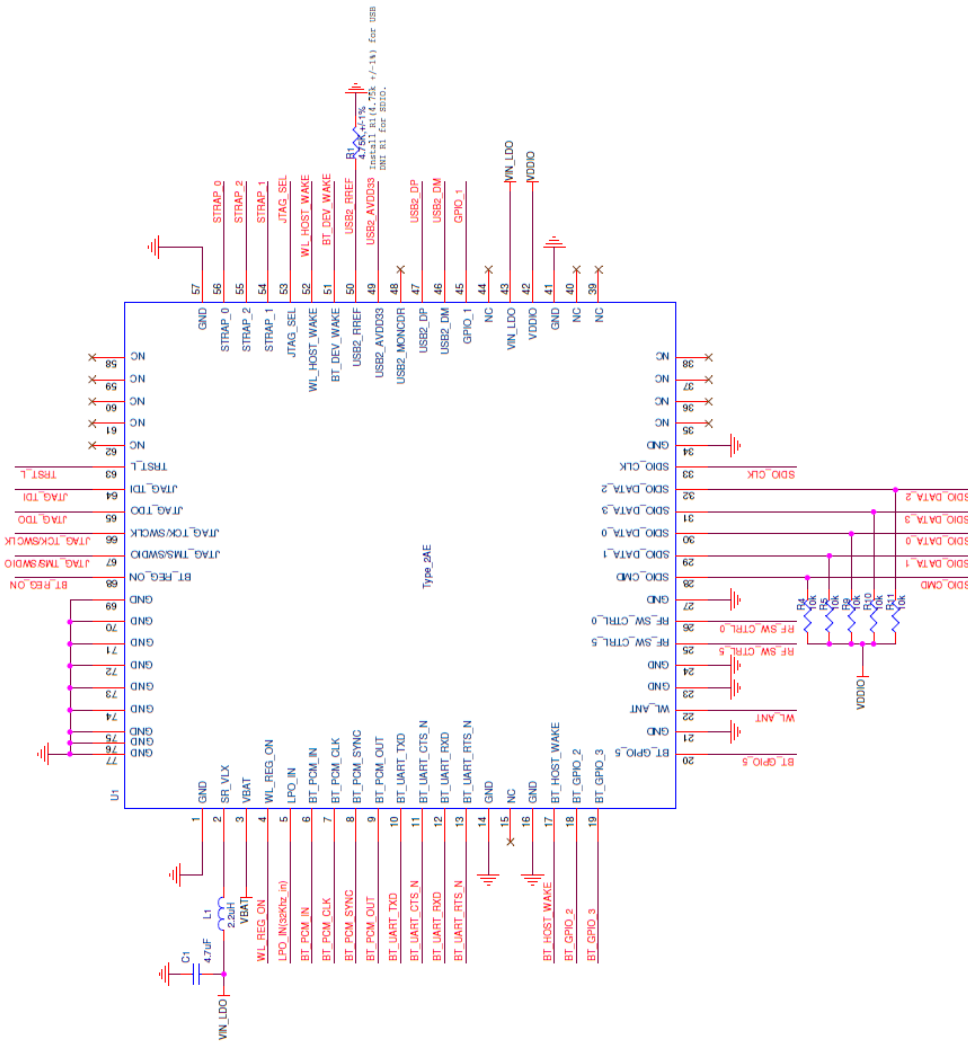

*1) SDIO Pull-UP Requirements

10 to 100k ohm pull-ups are required on the four DATA lines and the CMD line. This requirement must be met during all operating states by using external pull-up resistors or properly programming internal SDIO Host pull-ups. The CYW4373E module (LBEE5PK2AE-564) does not have internal pull-ups on these lines.

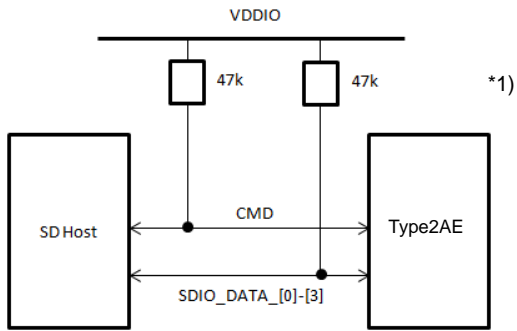

14. Tape and Reel Packing

(1) Dimensions of Tape (Plastic tape)

*1. Cumulative tolerance of max. 40.0 ± 0.15 every 10 pitches

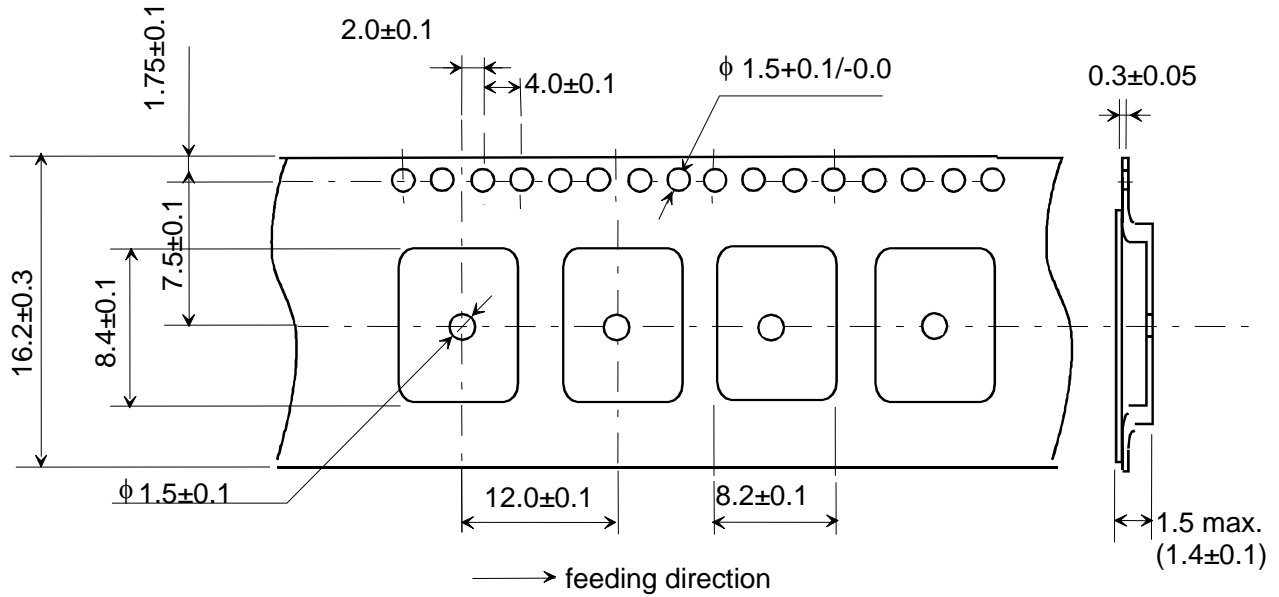

(Unit : mm)

(2) Dimensions of Reel

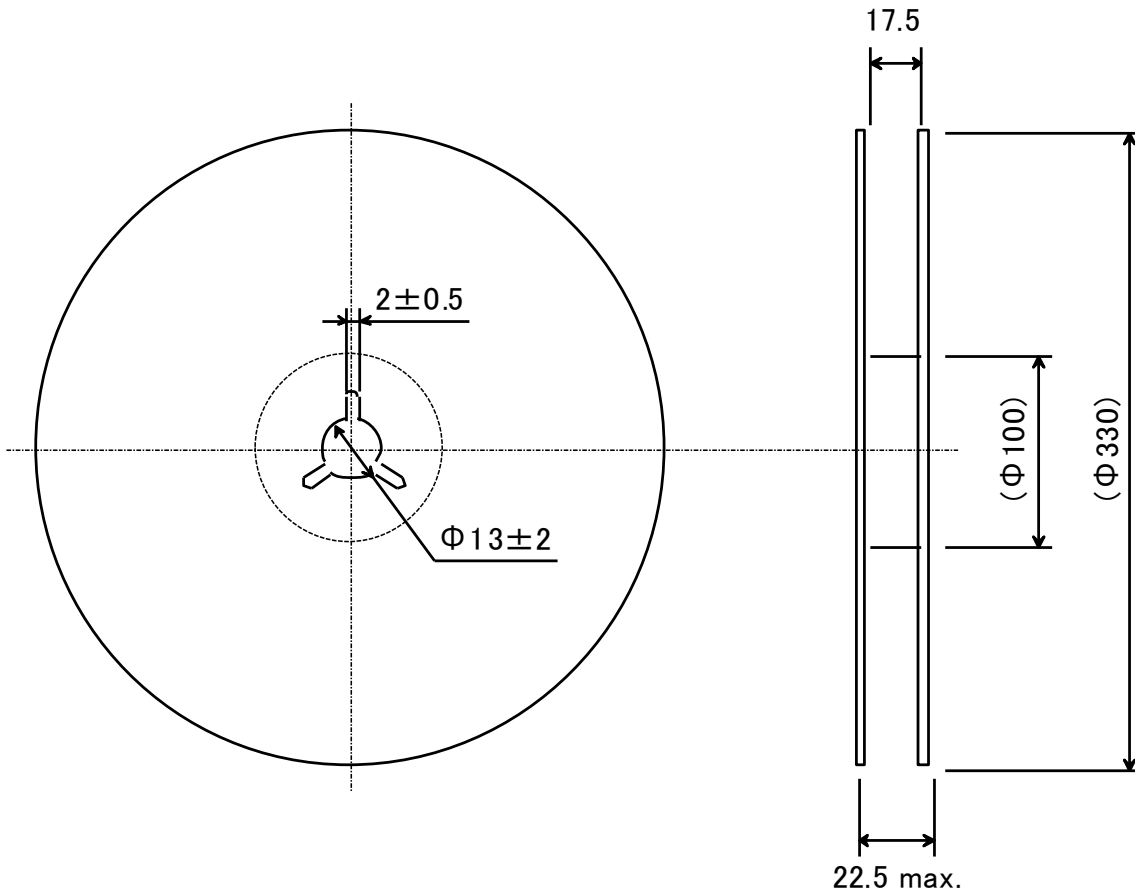

(unit : mm)

(3) Taping Diagrams

[1] Feeding Hole : As specified in (1)

[2] Hole for chip : As specified in (1)

[3] Cover tape : 62μm in thickness

[4] Base tape : As specified in (1)

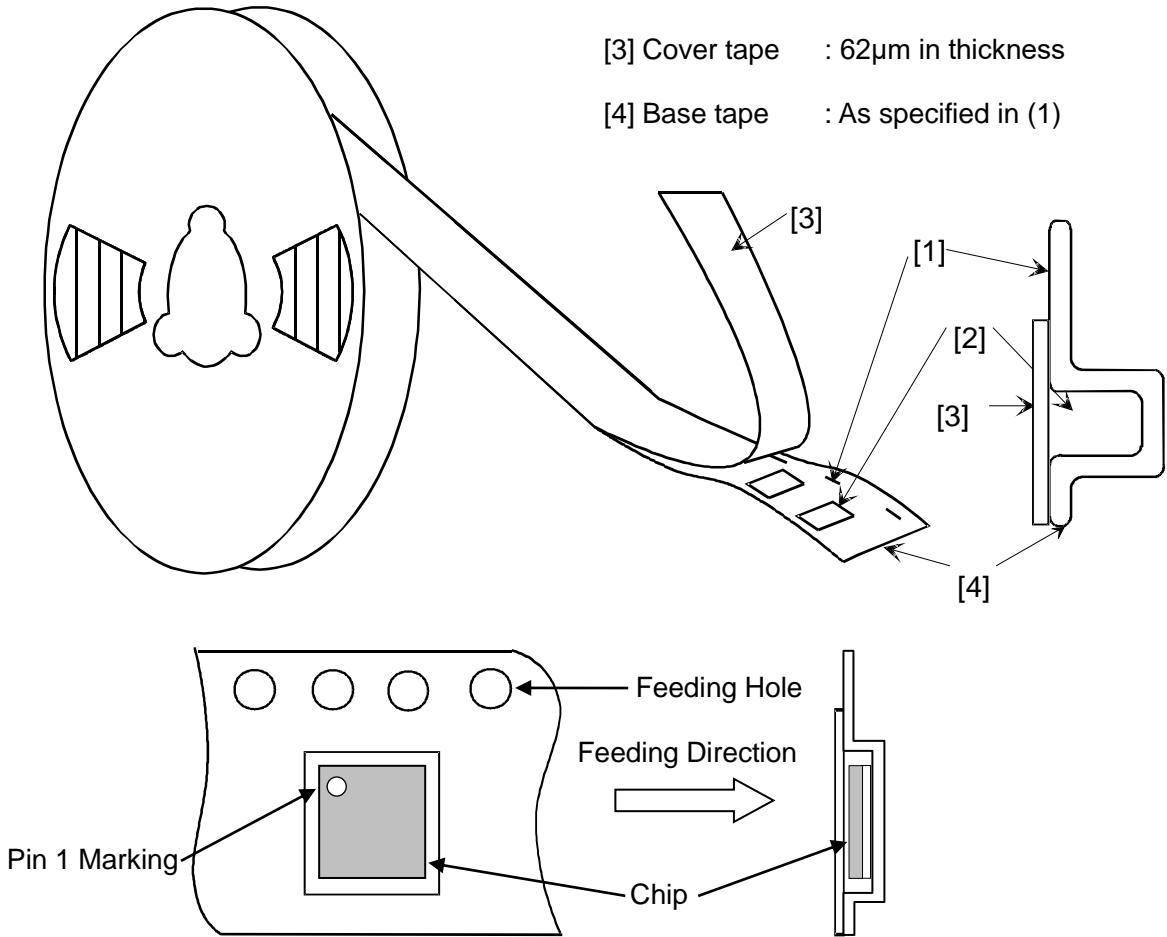

(4) Leader and Tail tape

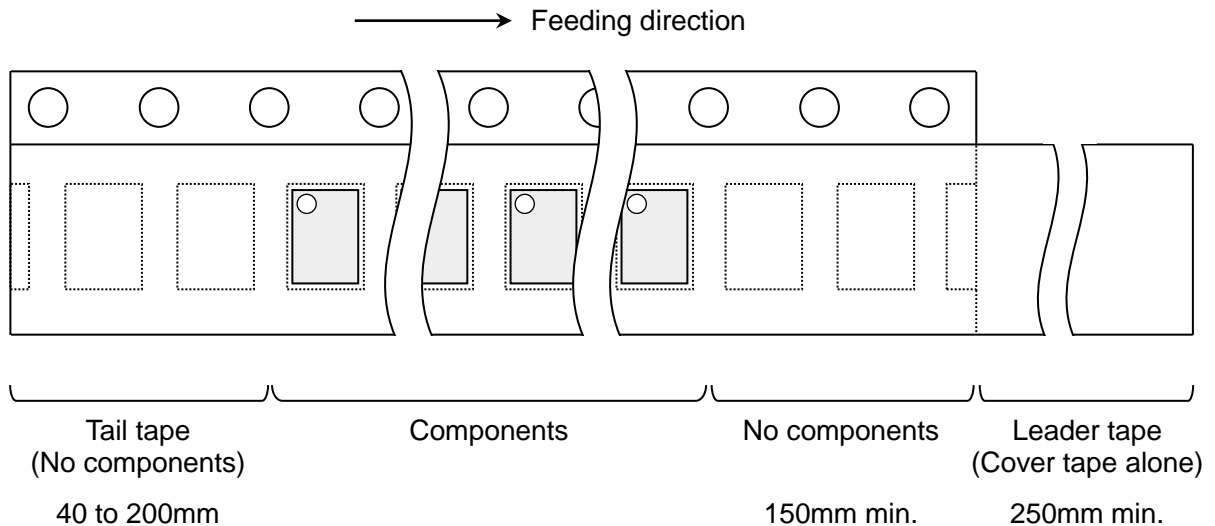

- (5) The tape for chips are wound clockwise, the feeding holes to the right side as the tape is pulled toward the user.
- (6) The cover tape and base tape are not adhered at no components area for 250mm min.
- (7) Tear off strength against pulling of cover tape : 5N min.
- (8) Packaging unit : 1000pcs./ reel
- (9) material : Base tape : Plastic
Real : Plastic
Cover tape, cavity tape and reel are made the anti-static processing.
- (10) Peeling of force : 1.1N max. in the direction of peeling as shown below.

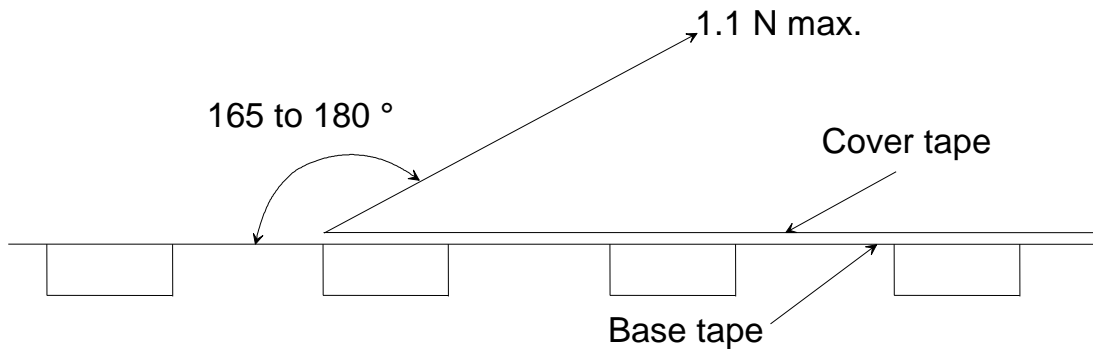

- (11) Packaging (Humidity proof Packing)

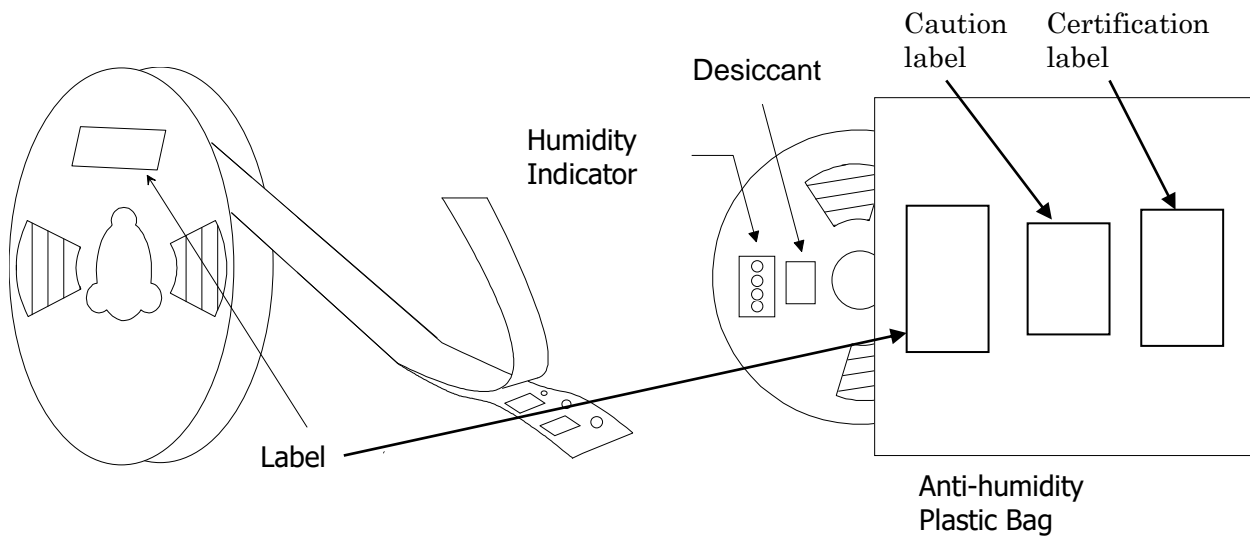

Tape and reel must be sealed with the anti-humidity plastic bag. The bag contains the desiccant and the humidity indicator.

15. Notice

15.1. Storage Conditions

Please use this product within 6month after receipt.

- The product shall be stored without opening the packing under the ambient temperature from 5 to 35 °C and humidity from 20 ~ 70 %RH.

(Packing materials, in particular, may be deformed at the temperature over 40 °C)

- The product left more than 6months after reception, it needs to be confirmed the solder ability before used.

- The product shall be stored in non-corrosive gas (CL₂, NH₃, SO₂, NO_x, etc.).

- Any excess mechanical shock including, but not limited to, sticking the packing materials by sharp object and dropping the product, shall not be applied in order not to damage the packing materials.

This product is applicable to MSL3 (Based on IPC/JEDEC J-STD-020)

- After the packing opened, the product shall be stored at <30 °C / <60 %RH and the product shall be used within 168 hours.

Please record and manage the time after opening.

- Product should be repacked with desiccating agent immediately after using.

- When the color of the indicator in the packing changed, the product shall be baked before soldering.

Baking condition: 125 +5/-0 °C, 24 hours, 1 time

The products shall be baked on the heat-resistant tray because the material (Base Tape, Reel Tape and Cover Tape) are not heat-resistant.

*For the MSL standard, see IPC/JEDEC J-STD-020 (can be downloaded from www.jedec.org).

If the storage environment is not conducted above standard conditions, it will cause some issue (e.g., Operation issue, Overcurrent, Malfunction) we shall not be responsible for that.

Before using please refer to "PRECONDITIONS TO USE MURATA PRODUCTS"

15.2. Handling Conditions

Be careful in handling or transporting products because excessive stress or mechanical shock may break products.

Handle with care if products may have cracks or damages on their terminals, the characteristics of products may change. Do not touch products with bear hands that may result in poor solder ability.

15.3. Standard PCB Design (Land Pattern and Dimensions)

All the ground terminals should be connected to the ground patterns. Furthermore, the ground pattern should be provided between IN and OUT terminals. Please refer to the specifications for the standard land dimensions.

The recommended land pattern and dimensions is as Murata's standard. The characteristics of products may vary depending on the pattern drawing method, grounding method, land dimensions, land forming method of the NC terminals and the PCB material and thickness. Therefore, be sure to verify the characteristics in the actual set. When using non-standard lands, contact Murata beforehand.

15.4. Notice for Chip Placer :

When placing products on the PCB, products may be stressed and broken by uneven forces from a worn-out chucking locating claw or a suction nozzle. To prevent products from damages, be sure to follow the specifications for the maintenance of the chip placer being used. For the positioning of products on the PCB, be aware that mechanical chucking may damage products.

15.5. Soldering Conditions :

The recommendation conditions of soldering are as in the following figure.

When products are immersed in solvent after mounting, pay special attention to maintain the temperature difference within 100 °C. Soldering must be carried out by the above mentioned conditions to prevent products from damage. Set up the highest temperature of reflow within 260 °C.

Contact Murata before use if concerning other soldering conditions.

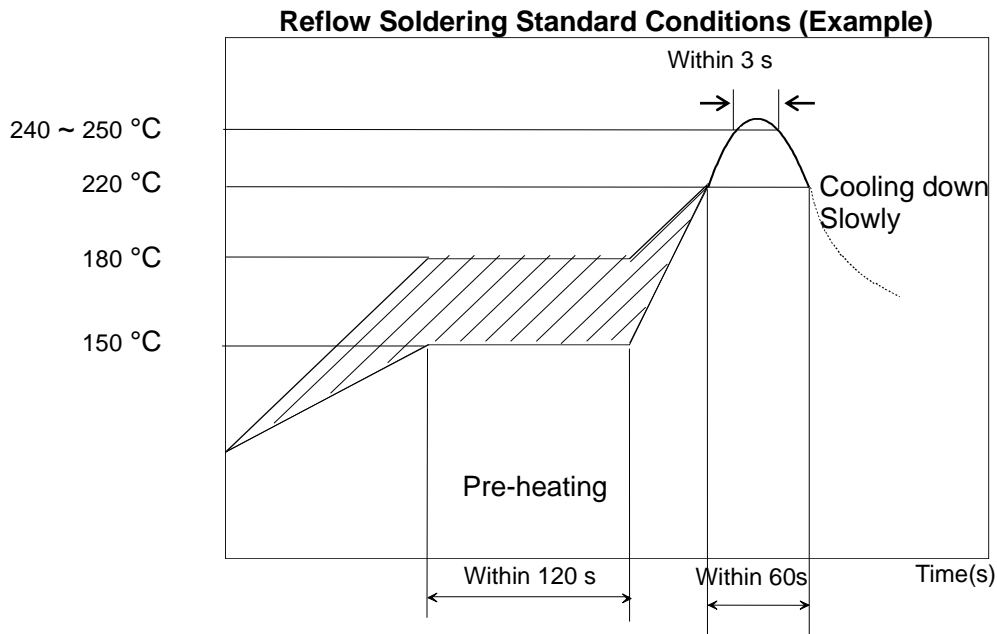

Please use the reflow within 2 times.

Use rosin Type flux or weakly active flux with a chlorine content of 0.2 wt % or less.

15.6. Cleaning :

Since this Product is Moisture Sensitive, any cleaning is not recommended. If any cleaning process is done the customer is responsible for any issues or failures caused by the cleaning process.

15.7. Operational Environment Conditions :

Products are designed to work for electronic products under normal environmental conditions (ambient temperature, humidity and pressure). Therefore, products have no problems to be used under the similar conditions to the above-mentioned. However, if products are used under the following circumstances, it may damage products and leakage of electricity and abnormal temperature may occur.

- In an atmosphere containing corrosive gas (CL₂, NH₃, SO_x, NO_x, etc.).
- In an atmosphere containing combustible and volatile gases.
- Dusty place.
- Direct sunlight place.
- Water splashing place.
- Humid place where water condenses.
- Freezing place.

If there are possibilities for products to be used under the preceding clause, consult with Murata before actual use.

As it might be a cause of degradation or destruction to apply static electricity to products, do not apply static electricity or excessive voltage while assembling and measuring.

15.8. Input Power Capacity :

Products shall be used in the input power capacity as specified in this specification.

Inform Murata beforehand, in case that the components are used beyond such input power capacity range.

16. Regulatory Statements

16.1. FCC Statements

T.B.D.

16.2. IC Statements

T.B.D.

17. PRECONDITION TO USE OUR PRODUCTS

PLEASE READ THIS NOTICE BEFORE USING OUR PRODUCTS.

Please make sure that your product has been evaluated and confirmed from the aspect of the fitness for the specifications of our product when our product is mounted to your product.

All the items and parameters in this product specification/datasheet/catalog have been prescribed on the premise that our product is used for the purpose, under the condition and in the environment specified in this specification. You are requested not to use our product deviating from the condition and the environment specified in this specification.

Please note that the only warranty that we provide regarding the products is its conformance to the specifications provided herein. Accordingly, we shall not be responsible for any defects in products or equipment incorporating such products, which are caused under the conditions other than those specified in this specification.

WE HEREBY DISCLAIMS ALL OTHER WARRANTIES REGARDING THE PRODUCTS, EXPRESS OR IMPLIED, INCLUDING WITHOUT LIMITATION ANY WARRANTY OF FITNESS FOR A PARTICULAR PURPOSE, THAT THEY ARE DEFECT-FREE, OR AGAINST INFRINGEMENT OF INTELLECTUAL PROPERTY RIGHTS.

You agree that you will use any and all software or program code (including but not limited to hcd, firmware, nvram, and blob) we may provide or to be embedded into our product ("Software") provided that you use the Software bundled with our product. YOU AGREE THAT THE SOFTWARE SHALL BE PROVIDED TO YOU "AS-IS" BASIS, MURATA MAKES NO REPRESENTATIONS OR WARRANTIES THAT THE SOFTWARE IS ERROR-FREE OR WILL OPERATE WITHOUT INTERRUPTION. AND MORE, MURATA MAKES NO REPRESENTATIONS OR WARRANTIES OF ANY KIND WHETHER EXPRESS OR IMPLIED WITH RESPECT TO THE SOFTWARE. MURATA EXPRESSLY DISCLAIM ANY AND ALL WARRANTIES OR CONDITIONS OF MERCHANTABILITY, FITNESS FOR A PARTICULAR PURPOSE NOR THE WARRANTY OF TITLE OR NON-INFRINGEMENT OF INTELLECTUAL PROPERTY RIGHTS.

You shall indemnify and hold harmless us, our affiliates and our licensor from and against any and all claims, costs, expenses and liabilities (including attorney's fees), which arise in connection with the using the Software.

The product shall not be used in any application listed below which requires especially high reliability for the prevention of such defect as may directly cause damage to the third party's life, body or property. You acknowledge and agree that, if you use our products in such applications, we will not be responsible for any failure to meet such requirements. Furthermore, YOU AGREE TO INDEMNIFY AND DEFEND US AND OUR AFFILIATES AGAINST ALL CLAIMS, DAMAGES, COSTS, AND EXPENSES THAT MAY BE INCURRED, INCLUDING WITHOUT LIMITATION, ATTORNEY FEES AND COSTS, DUE TO THE USE OF OUR PRODUCTS AND THE SOFTWARE IN SUCH APPLICATIONS.

- Aircraft equipment.
- Power plant control equipment
- Burning / explosion control equipment
- Transportation equipment (vehicles, trains, ships, elevator, etc.).
- Application of similar complexity and/ or reliability requirements to the applications listed in the above.
- Aerospace equipment
- Medical equipment.
- Disaster prevention / crime prevention equipment.
- Undersea equipment.
- Traffic signal equipment.

We expressly prohibit you from analyzing, breaking, reverse-engineering, remodeling altering, and reproducing our product. Our product cannot be used for the product which is prohibited from being manufactured, used, and sold by the regulations and laws in the world.

We do not warrant or represent that any license, either express or implied, is granted under any our patent right, copyright, mask work right, or our other intellectual property right relating to any combination, machine, or process in which our products or services are used. Information provided by us regarding third-party products or services does not constitute a license from us to use such products or services or a warranty or endorsement thereof. Use of such information may require a license from a third party under the patents or other intellectual property of the third party, or a license from us under our patents or other intellectual property.

Please do not use our products, our technical information and other data provided by us for the purpose of developing of mass-destruction weapons and the purpose of military use.

Moreover, you must comply with "foreign exchange and foreign trade law", the "U.S. export administration regulations", etc.

Please note that we may discontinue the manufacture of our products, due to reasons such as end of supply of materials and/or components from our suppliers.

By signing on specification sheet or approval sheet, you acknowledge that you are the legal representative for your company and that you understand and accept the validity of the contents herein. When you are not able to return the signed version of specification sheet or approval sheet within 30 days from receiving date of specification sheet or approval sheet, it shall be deemed to be your consent on the content of specification sheet or approval sheet. Customer acknowledges that engineering samples may deviate from specifications and may contain defects due to their development status. We reject any liability or product warranty for engineering samples. In particular we disclaim liability for damages caused by

- the use of the engineering sample other than for evaluation purposes, particularly the installation or integration in the product to be sold by you,
- deviation or lapse in function of engineering sample,
- improper use of engineering samples.

Preliminary

< Specification may be changed by Murata without notice >
Murata(China) Investment Co., Ltd.

We disclaim any liability for consequential and incidental damages.
If you can't agree the above contents, you should inquire our sales.

X-ON Electronics

Largest Supplier of Electrical and Electronic Components

Click to view similar products for [Multiprotocol Modules](#) category:

Click to view products by [Murata](#) manufacturer:

Other Similar products are found below :

[9260.NGWG.NV 958867](#) [AX210.NGWG.NV](#) [BM833](#) [ESP32-C3-MINI-1U-H4](#) [ESP32-WROOM-32U-16MB](#) [ESP32-WROOM-32UE](#)
[ESP32-WROOM-32D-H4](#) [ESP32-WROOM-32U-H4](#) [ESP32-PICO-MINI-02U-N8R2](#) [ESP32-C6-WROOM-1-N4](#) [ESP32-C6-WROOM-1U-N4](#)
[ESP32-C6-WROOM-1-N8](#) [BE200.NGWG.NV](#) [BE200.NGWG](#) [BE202.NGWG.NV](#) [BE200.NGWG.NVX](#) [AX411.NGWG.NV](#) [AX210.D2WG](#)
[AX210.NGWG.NVX](#) [AX211.NGWG](#) [EC200UEUAA-N05-TA0AA](#) [SC20ELSATEA-8GB-UGAD](#) [SG560DEUPA-U61-TA0AA](#)
[AX211.NGWG.NV](#) [ISM43340-M4G-L44-10CF-C6.2.1.11](#) [KG100SABMD](#) [BC40P](#) [S007-PIN254](#) [S007-PIN127](#) [ESP32-C3-12F](#)
[FC41DAHMD](#) [EWM-W179M201E](#) [ESP32-C6-WROOM-1U-N8](#) [ATWILC3000-MR110CA](#) [RS9113-NBZ-D5W](#) [ATWINC3400-](#)
[MR210UA122](#) [ESP32-WROOM-32](#) [AMPAK AP12356 WIFI/BT KIT](#) [AIW-154BN](#) [AIW-165BN](#) [AIW-166K1](#) [AIW-166K2](#) [AIW-166K3](#)
[AIW-166K4](#) [AIW-355 DQ-N01](#) [AIW-355 DQ-C01](#) [EWM-W159M201E](#) [EWM-W192K1](#) [EWM-W192K2](#) [W106C](#)