

# Type 1YM Wi-Fi<sup>®</sup> + Bluetooth<sup>®</sup> Module

NXP 88W8997 Chipset for 802.11a/b/g/n/ac 2x2 MIMO +  
Bluetooth 5.2 Datasheet - Rev. R

- Design Name: Type 1YM
- P/N: LBEE5XV1YM-574



## Table of Contents

1 Scope .....	8
2 Key Features .....	8
3 Ordering Information .....	8
4 Block Diagram .....	9
5 Certification Information .....	10
5.1 Radio Certification .....	10
5.2 Bluetooth Qualification .....	10
6 Dimensions, Markings and Terminal Configurations .....	11
7 Module Pin Descriptions .....	12
7.1 Pin Assignments .....	12
7.2 Pin Descriptions .....	13
7.3 Configuration Pins .....	17
7.4 Pin States .....	18
8 Absolute Maximum Ratings .....	19
9 Operating Conditions .....	20
9.1 Operating Conditions .....	20
9.2 External Sleep Clock Requirements .....	21
9.3 Digital I/O Requirements .....	21
9.4 Package Thermal Conditions .....	21
10 Power Sequence .....	22
10.1 Power-On Sequence .....	22
10.2 Power-Off Sequence .....	23
11 Host Interface Specification .....	24
11.1 SDIO Specifications .....	24
11.1.1 Default Speed, High Speed Modes .....	24
11.1.2 SDR12, SDR25, SDR50 Modes up to 100 MHz (1.8 V) .....	25
11.1.3 SDR104 Mode at 208 MHz (1.8 V) .....	26
11.1.4 DDR50 Mode at 50 MHz (1.8 V) .....	27
11.2 PCI Express Specifications .....	30
11.2.1 Differential Tx Output Electricals .....	30
11.2.2 Differential Rx Input Electricals .....	32
11.3 USB Specifications .....	34
11.3.1 USB LS Driver and Receiver Parameters .....	34
11.3.2 USB FS Driver and Receiver Parameters .....	35
11.4 High Speed UART Specifications .....	36

12 DC/RF Characteristics .....	36
12.1 DC/RF Characteristics for IEEE 802.11b - 2.4 GHz.....	37
12.1.1 High-Rate Condition for IEEE 802.11b - 2.4 GHz .....	37
12.1.2 Low-Rate Condition for IEEE 802.11b - 2.4 GHz .....	38
12.2 DC/RF Characteristics for IEEE 802.11g - 2.4 GHz.....	39
12.2.1 High-Rate Condition for IEEE 802.11g - 2.4 GHz .....	39
12.2.2 Low-Rate Condition for IEEE 802.11g - 2.4 GHz .....	40
12.3 DC/RF Characteristics for IEEE 802.11n - 2.4 GHz.....	41
12.3.1 High-Rate Condition for IEEE 802.11n - 2.4 GHz .....	41
12.3.2 Low-Rate Condition for IEEE 802.11n - 2.4 GHz .....	42
12.4 DC/RF Characteristics for IEEE 802.11a - 5 GHz.....	43
12.4.1 High-Rate Condition for IEEE 802.11a - 5 GHz .....	43
12.4.2 Low-Rate for IEEE 802.11a - 5 GHz.....	44
12.5 DC/RF Characteristics for IEEE 802.11n (HT20) - 5 GHz.....	45
12.5.1 High-Rate Condition for IEEE 802.11n (HT20) - 5 GHz .....	45
12.5.2 Low-Rate Condition for IEEE 802.11n (HT20) - 5 GHz .....	46
12.6 DC/RF Characteristics for IEEE 802.11ac (VHT20) - 5 GHz .....	47
12.6.1 High-Rate Condition for IEEE 802.11ac (VHT20) - 5 GHz .....	47
12.6.2 Low-Rate Condition for IEEE 802.11ac (VHT20) - 5 GHz .....	48
12.7 DC/RF Characteristics for IEEE 802.11n (HT40) - 5 GHz.....	49
12.7.1 High-Rate Condition for IEEE 802.11n (HT40) - 5 GHz .....	49
12.7.2 Low-Rate Condition for IEEE 802.11n (HT40) - 5 GHz .....	50
12.8 DC/RF Characteristics for IEEE 802.11ac (VHT40) - 5 GHz .....	51
12.8.1 High-Rate Condition for IEEE 802.11ac (VHT40) - 5 GHz .....	51
12.8.2 Low-Rate Condition for IEEE 802.11ac (VHT40) - 5 GHz.....	52
12.9 DC/RF Characteristics for IEEE 802.11ac (VHT80) - 5 GHz .....	53
12.9.1 High-Rate Condition for IEEE 802.11ac (VHT80) - 5 GHz .....	53
12.9.2 Low-Rate Condition for IEEE 802.11ac (VHT80) - 5 GHz.....	54
12.10 DC/RF Characteristics for Bluetooth.....	55
12.10.1 Basic Data Rate Condition.....	55
12.10.2 Enhanced Data Rate Condition .....	56
12.11 DC/RF Characteristics for Bluetooth Low Energy .....	57
12.11.1 1 Mbps PHY Condition .....	57
12.11.2 2 Mbps PHY Condition .....	58
13 Land Pattern .....	60
14 General Regulatory Certification for LBEE5XV1YM .....	61
14.1 Application Model Part Number .....	61

14.2 Label .....	61
14.3 Package Label .....	61
14.4 Country of Origin .....	62
15 Radio Regulatory Certification by Country for LBEE5XV1YM .....	63
15.1 Japan .....	63
15.1.1 Power Levels for Japan .....	63
15.1.2 Antenna List .....	65
15.1.3 About Notations .....	65
15.2 FCC .....	66
15.2.1 Supply Voltage .....	66
15.2.2 Power Level for FCC .....	67
15.2.3 Theory of Operation for FCC .....	69
15.2.4 Information to Include in the User Manual .....	69
15.2.5 Compliance with FCC requirement 15.407(c) .....	70
15.2.6 Equipment Installation for FCC .....	70
15.3 ISED .....	71
15.3.1 Information to Display on Host Device and User Manual .....	71
15.3.2 Antenna Installation in End Product .....	72
15.3.3 Equipment Installation for ISED .....	73
15.3.4 Power Level for ISED .....	73
15.3.5 Theory of Operation for ISED .....	76
15.4 Europe .....	77
15.4.1 Power Level for Europe .....	77
15.4.2 Theory of Operation for Europe .....	79
16 Tape and Reel Packing .....	80
16.1 Dimensions of Tape (Plastic Tape) .....	80
16.2 Dimensions of Reel .....	81
16.3 Taping Diagrams .....	82
16.4 Leader and Tail Tape .....	83
16.5 Packaging (Humidity Proof Packing) .....	84
17 Notice .....	85
17.1 Storage Conditions .....	85
17.2 Handling Conditions .....	85
17.3 Standard PCB Design (Land Pattern and Dimensions) .....	85
17.4 Notice for Chip Placer .....	86
17.5 Soldering Conditions .....	86
17.6 Cleaning .....	86

17.7 Operational Environment Conditions .....	87
17.8 Input Power Capacity .....	87
18 Preconditions to Use Our Products .....	88
Revision History.....	90

## Figures

Figure 1: Block Diagram .....	9
Figure 2: Dimensions, Markings, and Terminal Configurations .....	11
Figure 3: Pin Assignments (Top View) .....	12
Figure 4: Package Thermal Conditions .....	22
Figure 5: Power-On Sequence Graph.....	22
Figure 6: Power-Off Sequence Graph.....	23
Figure 7: SDIO Protocol Timing Diagram - Default Speed Mode (3.3V) .....	24
Figure 8: SDIO Protocol Timing Diagram - High Speed Mode (3.3V).....	24
Figure 9: SDIO Protocol Timing Diagram - SDR12, SDR25, SDR50 Modes .....	25
Figure 10: SDIO Protocol Timing Diagram - SDR104 Mode.....	26
Figure 11: SDIO CMD Timing Diagram - DDR50 Mode .....	27
Figure 12: SDIO DAT[3:0] Timing Diagram - DDR50 Mode .....	28
Figure 13: High Speed UART Specifications.....	36
Figure 14: Burst current definition .....	36
Figure 15: Land Pattern .....	60
Figure 16: Radio Regulatory Certification Label .....	61
Figure 17: Package Label (Humidity proof Packing) .....	62
Figure 18: Package Label Display Example.....	62
Figure 19: Dimensions of Tape (Plastic tape) .....	80
Figure 20: Dimensions of Reel (Unit: mm) .....	81
Figure 21: Taping Diagrams.....	82
Figure 22: Leader and Tail Tape.....	83
Figure 23: Peeling Force.....	83
Figure 24: Humidity Proof Packaging.....	84
Figure 25: Reflow soldering standard conditions (Example).....	86

## Tables

Table 1: Document Conventions.....	7
Table 2: Ordering Information .....	8
Table 3: Transmit Power Limit Files .....	10
Table 4: Markings .....	11

Table 5: Dimensions .....	11
Table 6: Terminal Configurations .....	13
Table 7: Pin Descriptions .....	13
Table 8: Configuration Pins.....	17
Table 9: Firmware Download Mode .....	17
Table 10: I/O State Table.....	18
Table 11: Absolute and Maximum Ratings.....	19
Table 12: Operating Conditions .....	20
Table 13: External Sleep Clock Requirements.....	21
Table 14: Digital I/O Requirements Parameters.....	21
Table 15: Parameters for Power-On Sequence.....	23
Table 16: Parameters for Power-Off Sequence.....	23
Table 17: SDIO Timing Data - Default Speed, High Speed Modes (3.3V).....	25
Table 18: SDIO Timing Data - SDR12, SDR25, SDR50 Modes .....	26
Table 19: SDIO Timing Data - SDR104 Mode.....	26
Table 20: SDIO Timing Data - DDR50 Mode (50 MHz).....	28
Table 21: PCI Express Tx Output Specifications Data - 2.5 GT/s.....	30
Table 22: PCI Express Tx Output Specifications Data - 5 GT/s.....	31
Table 23: PCI Express Rx Input Specifications Data - 2.5 GT/s .....	32
Table 24: PCI Express Rx Input Specifications Data - 5 GT/s.....	33
Table 25: USB LS Driver and Receiver Specifications Data.....	34
Table 26: USB FS Driver and Receiver Specifications Data .....	35
Table 27: High Speed UART Specifications Parameters.....	36
Table 28: DC/RF Characteristics and Files .....	36
Table 29: High-Rate Condition for IEEE 802.11b - 2.4 GHz.....	37
Table 30: Low-Rate Condition for IEEE 802.11b - 2.4 GHz.....	38
Table 31: High-Rate Condition for IEEE 802.11g - 2.4 GHz.....	39
Table 32: Low-Rate Condition for IEEE 802.11g - 2.4 GHz.....	40
Table 33: High-Rate Condition for IEEE 802.11n - 2.4 GHz.....	41
Table 34: Low-Rate Condition for IEEE 802.11n - 2.4 GHz.....	42
Table 35: High-Rate Condition for IEEE 802.11a - 5 GHz.....	43
Table 36: Low-Rate Condition for IEEE 802.11a - 5 GHz.....	44
Table 37: High-Rate Condition for IEEE 802.11n (HT20) - 5 GHz.....	45
Table 38: Low-Rate Condition for IEEE 802.11n (HT20) - 5 GHz.....	46
Table 39: High-Rate Condition for IEEE 802.11ac (VHT20) - 5 GHz.....	47
Table 40: Low-Rate Condition for IEEE 802.11ac (VHT20) - 5 GHz.....	48
Table 41: High-Rate Condition for IEEE 802.11n (HT40) - 5 GHz.....	49
Table 42: Low-Rate Condition for IEEE 802.11n (HT40) - 5 GHz.....	50
Table 43: High-Rate Condition for IEEE 802.11ac (VHT40) - 5 GHz.....	51
Table 44: Low-Rate Condition for IEEE 802.11ac (VHT40) - 5 GHz.....	52

Table 45: High-Rate Condition for IEEE 802.11ac (VHT80) - 5 GHz.....	53
Table 46: Low-Rate Condition for IEEE 802.11ac (VHT80) - 5 GHz.....	54
Table 47: Basic Data Rate Condition .....	55
Table 48: Enhanced Data Rate Condition.....	56
Table 49: 1 Mbps PHY Condition .....	57
Table 50: 2 Mbps PHY Condition .....	58
Table 51: Japan Power Level 2.4 GHz WLAN Per Antenna Port .....	63
Table 52: Japan Power Level 2.4 GHz BT/BLE Per Antenna Port .....	64
Table 53: Japan Power Level 5 GHz WLAN Per Antenna Port (W52).....	64
Table 54: Japan Power Level 5 GHz WLAN Per Antenna Port (W53).....	64
Table 55: Japan Power Level 5 GHz WLAN Per Antenna Port (W56).....	64
Table 56: Antenna Registered Under the Japan Radio Act .....	65
Table 57: Supply Voltage.....	66
Table 58: FCC Power Level 2.4 GHz WLAN Per Antenna Port.....	67
Table 59: FCC Power Level 2.4 GHz BT/BLE Per Antenna Port.....	67
Table 60: FCC Power Level 5 GHz WLAN Per Antenna Port.....	67
Table 61: FCC Theory of Operation for WLAN.....	69
Table 62: ISED Power Level 2.4 GHz WLAN Per Antenna Port.....	74
Table 63: ISED Power Level 2.4 GHz BT/BLE Per Antenna Port.....	74
Table 64: ISED Power Level 5 GHz WLAN Per Antenna Port.....	74
Table 65: ISED Theory of Operation for WLAN.....	76
Table 66: Maximum Radio Frequency Power - All Band .....	77
Table 67: Europe Power Level 2.4 GHz WLAN Per Antenna port.....	77
Table 68: Europe Power Level 2.4 GHz BT/BLE Per Antenna port.....	78
Table 69: Europe Power Level 5 GHz WLAN Per Antenna port.....	78
Table 70: Europe Theory of Operation for WLAN.....	79
Table 71: Taping Specifications .....	82

## About This Document

Murata's Type 1YM is a small and high-performance module based on NXP 88W8997 combo chipset, supporting IEEE 802.11a/b/g/n/ac 2x2 MIMO + Bluetooth 5.2 BR/EDR/LE. This datasheet describes Type 1YM module in detail.



Please be aware that an important notice concerning availability, standard warranty and use in critical applications of Murata products and disclaimers thereto appears at the end of this specification sheet.









## Audience & Purpose

Intended audience includes any customer looking to integrate this module into their product; specifically RF, hardware, software, and systems engineers.

## Document Conventions

**Table 1** describes the document conventions.

**Table 1: Document Conventions**

Conventions	Description
	<b>Warning Note</b> Indicates very important note. Users are strongly recommended to review.
	<b>Info Note</b> Intended for informational purposes. Users should review.
	<b>Menu Reference</b> Indicates menu navigation instructions. <b>Example:</b> Insert → Tables → Quick Tables → Save Selection to Gallery 
	<b>External Hyperlink</b> This symbol indicates a hyperlink to an external document or website. <b>Example:</b> <a href="#">Embedded Artists AB</a>  Click on the text to open the external link.
	<b>Internal Hyperlink</b> This symbol indicates a hyperlink within the document. <b>Example:</b> <a href="#">Scope</a>  Click on the text to open the link.
<code>Console input/output or code snippet</code>	<b>Console I/O or Code Snippet</b> This text <b>Style</b> denotes console input/output or a code snippet.
<code># Console I/O comment // Code snippet comment</code>	<b>Console I/O or Code Snippet Comment</b> This text <b>Style</b> denotes a console input/output or code snippet comment. <ul style="list-style-type: none"> <li>• Console I/O comment (preceded by "#") is for informational purposes only and does not denote actual console input/output.</li> <li>• Code Snippet comment (preceded by "//") may exist in the original code.</li> </ul>





## 1 Scope

This specification applies to the IEEE 802.11a/b/g/n/ac WLAN 2x2 MU-MIMO + Bluetooth 5.2 combo module.

## 2 Key Features

- ◆ NXP 88W8997 inside
- ◆ Supports IEEE 802.11a/b/g/n/ac specification: Dual band 2.4 GHz and 5 GHz
- ◆ MU-MIMO with 20 MHz, 40 MHz, and 80 MHz channels
- ◆ Up to MCS9 data rates (866 Mbps)
- ◆ Supports Bluetooth specification version 5.2
- ◆ For supported Bluetooth functions, refer to [Bluetooth SIG site](#) 
- ◆ WLAN interface: PCIe 3.0, SDIO 3.0, USB 2.0 & 3.0
- ◆ Bluetooth interface: HCI UART, SDIO 3.0, USB 2.0 & 3.0, and PCM
- ◆ Temperature Range: - 30 °C to 85 °C
- ◆ Dimensions: 11.8 x 8.4 x 1.3 mm
- ◆ Weight: 352 mg
- ◆ MSL: 3
- ◆ Surface-mount type
- ◆ RoHS compliant



WLAN-USB, Bluetooth-SDIO, and Bluetooth-USB interfaces may not be supported.  
Refer to [Type 1YM webpage](#)  or check [1YM Community Forum page](#) .

## 3 Ordering Information

**Table 2** shows the ordering information for Type 1YM module.

**Table 2: Ordering Information**

Ordering Part Number	Description
LBEE5XV1YM-574	Module order
LBEE5XV1YM-SMP	Sample module order (If module samples are not available through distribution, contact Murata referencing this part number)
EAR00370	Embedded Artists Type 1YM M.2 EVB (default EVB available through distribution)

## 4 Block Diagram

The Type 1YM block diagram is presented in **Figure 1**.

**Figure 1: Block Diagram**

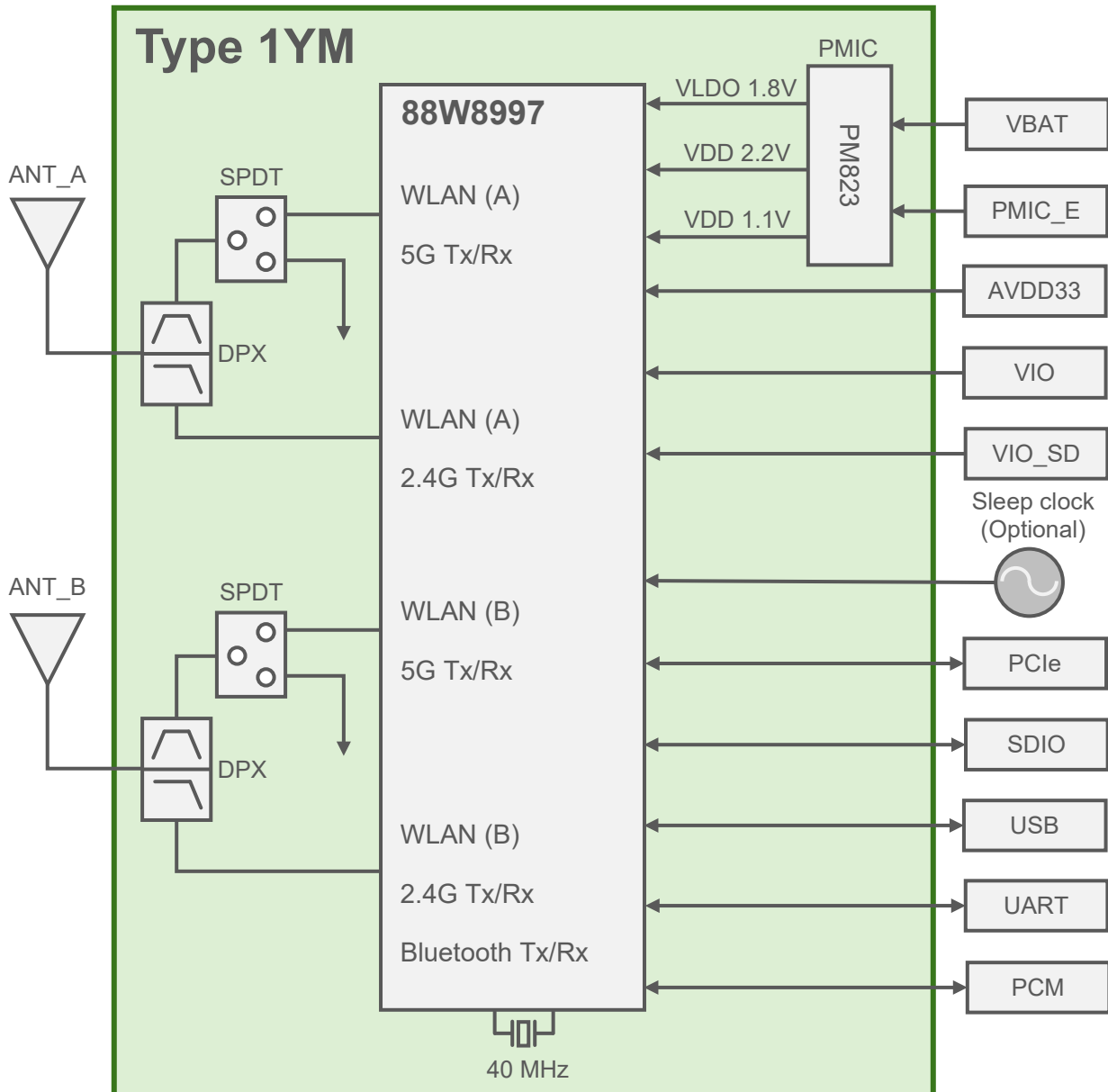

WLAN-USB, Bluetooth-SDIO, and Bluetooth-USB interfaces may not be supported.  
Refer to [Type 1YM webpage](#) or check [1YM Community Forum page](#).

## 5 Certification Information

This section has information about radio and Bluetooth certification.

### 5.1 Radio Certification

Transmit output power setting is defined by “txpower\_XX.bin” (XX is country code). The transmit power files are hosted at Murata GitHub for [Linux](#) [↗](#). **Table 3** shows the transmit power file required for each region.

**Table 3: Transmit Power Limit Files**

Country	ID	Country Code	Tx Power Limit File
USA (FCC)	VPYLB1YM	US	txpower_US.bin
Canada (IC)	772C-LB1YM	CA	txpower_CA.bin
Europe	EN300328/301893, EN300440 conducted test report is prepared.	DE	txpower_EU.bin
Japan	Japanese type certification is prepared.  001-P01563	JP	txpower_JP.bin



Each country code is defined by Murata's db.txt file. Please ask your contact person from Murata.

### 5.2 Bluetooth Qualification

- QDID: 157698
- Set Bluetooth Tx Power to Class 1 by using [bt\\_power\\_config\\_1.sh](#) [↗](#).
- For PICS for supported Bluetooth functions refer to [Bluetooth SIG site](#) [↗](#).

## 6 Dimensions, Markings and Terminal Configurations

This section has information on dimensions, marking, and terminal configurations for Type 1YM.

Figure 2: Dimensions, Markings, and Terminal Configurations

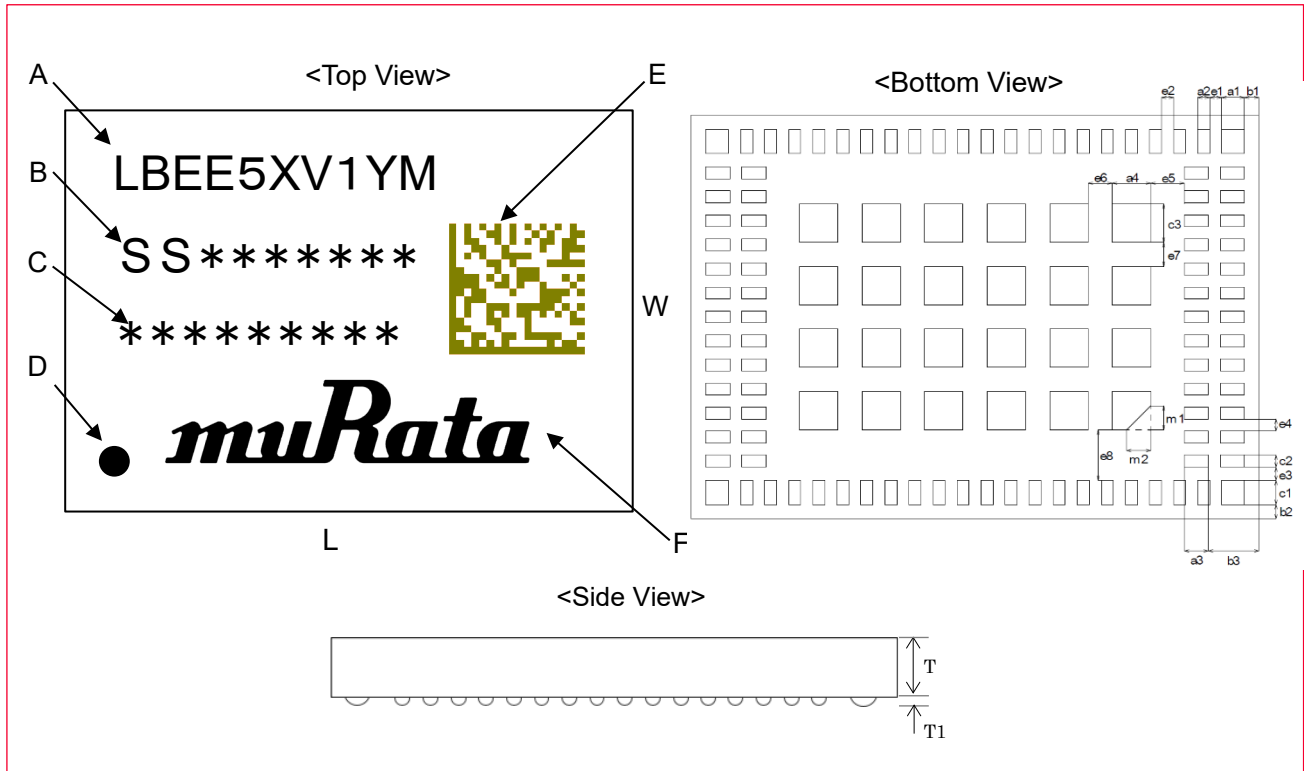

Table 4: Markings

Marking	Meaning
A	Module Type
B	Production Process Number
C	Serial Number
D	Pin 1 Marking
E	2D code
F	Murata Logo

Table 5: Dimensions

Mark	Dimensions (mm)	Mark	Dimensions (mm)	Mark	Dimensions (mm)	Mark	Dimensions (mm)
L	11.8 ± 0.2	W	8.4 ± 0.2	T	1.3 maximum	a1	0.475 ± 0.1
a2	0.25 ± 0.1	a3	0.5 ± 0.2	a4	0.8 ± 0.1	b1	0.3 ± 0.2
b2	0.3 ± 0.2	b3	1.05 ± 0.2	c1	0.5 ± 0.1	c2	0.25 ± 0.1
c3	0.8 ± 0.1	e1	0.25 ± 0.1	e2	0.25 ± 0.1	e3	0.25 ± 0.1
e4	0.25 ± 0.1	e5	0.7 ± 0.1	e6	0.5 ± 0.1	e7	0.5 ± 0.1
e8	1.05 ± 0.1	m1	0.5 ± 0.2	m2	0.5 ± 0.2	T1	0.045 typical

## 7 Module Pin Descriptions

This section has the Pin descriptions of Type 1YM and pin assignments layout descriptions.

### 7.1 Pin Assignments

The pin assignment layout (Top View) is shown in **Figure 3**.

**Figure 3: Pin Assignments (Top View)**

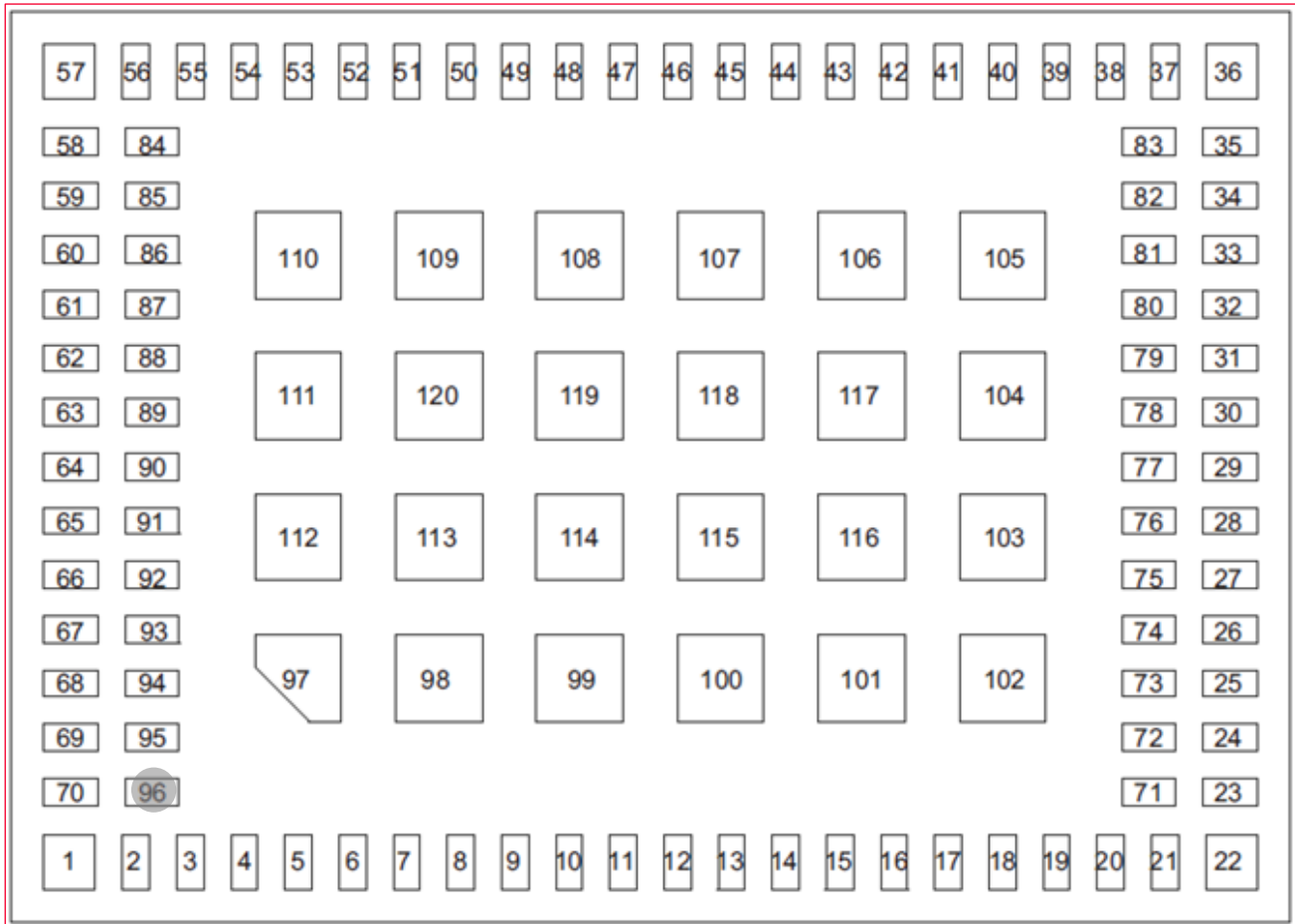

**Table 6** illustrates the terminal configurations.

**Table 6: Terminal Configurations**

No.	Terminal Name	No.	Terminal Name	No.	Terminal Name
1	GND	29	GND	57	GND
2	GPIO[24]	30	PMIC_EN	58	GND
3	GPIO[3]	31	GPIO[21]	59	WLAN_RF_A
4	GPIO[2]	32	PCIE_WAKE_N	60	GND
5	GPIO[17]	33	GPIO[5]	61	GPIO[6]
6	GPIO[16]	34	DNC	62	GPIO[9]
7	GPIO[15]	35	DNC	63	GPIO[8]
8	GPIO[14]	36	GND	64	GPIO[13]
9	VIO	37	GND	65	GPIO[10]
10	GPIO[20]	38	GND	66	GPIO[11]
11	GPIO[25]	39	PCIE_RXP	67	GPIO[12]
12	GND	40	PCIE_RXN	68	GND
13	NC	41	PCIE_TXP	69	WLAN_RF_B
14	NC	42	PCIE_TXN	70	GND
15	GND	43	PCIE_CLKP	71	GPIO[26]
16	VIO_SD	44	PCIE_CLKN	72	GPIO[27]
17	AVDD33	45	GND	73	GPIO[18]
18	SD_D1	46	GPIO[4]	74	GND
19	SD_D0	47	GPIO[0]	75	VBAT
20	SD_CLK	48	DNC	76	VBAT
21	SD_CMD	49	DNC	77	GND
22	GND	50	AVDD18	78	GPIO[1]
23	SD_D3	51	DNC	79	GPIO[23]
24	SD_D2	52	CONFIG_HOST_3	80	GPIO[22]
25	GPIO[19]	53	CONFIG_HOST_2	81	GPIO[7]
26	GND	54	CONFIG_HOST_1	82	PCIE_CLKREQ_N
27	VBAT	55	CONFIG_HOST_0	83	DNC
28	VBAT	56	SLP_CLK	84-120	GND

## 7.2 Pin Descriptions

**Table 7** describes Type 1YM Pins.





**Table 7: Pin Descriptions**

No.	Pin name	Type	Connection to IC Pin Name <sup>1</sup>	Description
1	GND	Ground		Ground
2	GPIO[24]	I/O	GPIO[24]	Programmable GPIO
3	GPIO[3]	I/O	GPIO[3]	Programmable GPIO
4	GPIO[2]	I/O	GPIO[2]	Programmable GPIO
5	GPIO[17]	I/O	GPIO[17]	Programmable GPIO
6	GPIO[16]	I/O	GPIO[16]	Programmable GPIO
7	GPIO[15] (HOST_WAKEUP_WLAN) <sup>2</sup>	I/O	GPIO[15]	Programmable GPIO

<sup>1</sup> ( ) of "pin name" is BSP configuration of NXP iMX8.

<sup>2</sup> NXP recommended GPIO. Check whether NXP software can support this function or not

No.	Pin name	Type	Connection to IC Pin Name <sup>1</sup>	Description
8	GPIO[14] (WLAN_WAKEUP_HOST <sup>2</sup> )	I/O	GPIO[14]	Programmable GPIO
9	VIO	Power	VIO	Power Supply
10	GPIO[20]	I/O	GPIO[20]	Programmable GPIO
11	GPIO[25]	I/O	GPIO[25]	Programmable GPIO
12	GND	Ground		Ground
13	NC	I/O	USB_DMNS	USB Serial Differential Data-Negative
14	NC	I/O	USB_DPLS	USB Serial Differential Data-Positive
15	GND	Ground		Ground
16	VIO_SD	Power	VIO_SD	1.8V/3.3V Digital I/O SDIO Power Supply
17	AVDD33	Power	AVDD33	3.3V Analog Power Supply
18	SD_D1	I/O	SD_DAT[1]	SDIO 4-bit mode: Data line Bit[1] SDIO 1-bit mode: Interrupt
19	SD_D0	I/O	SD_DAT[0]	SDIO 4-bit mode: Data line Bit[0] SDIO 1-bit mode: Data line
20	SD_CLK	I/O	SD_CLK	SDIO 4-bit mode: Clock SDIO 1-bit mode: Clock
21	SD_CMD	I/O	SD_CMD	SDIO 4-bit mode: Command line SDIO 1-bit mode: Command line
22	GND	Ground		Ground
23	SD_D3	I/O	SD_DAT[3]	SDIO 4-bit mode: Data line Bit[3] SDIO 1-bit mode: Not used
24	SD_D2	I/O	SD_DAT[2]	SDIO 4-bit mode: Data line Bit[2] or Read Wait (optional) SDIO 1-bit mode: Interrupt (optional)
25	NC (GPIO [19])	I/O	GPIO[19] DVS1(PMIC)	NC
26	GND	Ground		Ground
27	VBAT	Power	PVIN(PMIC)	Power Supply
28	VBAT	Power	PVIN(PMIC)	Power Supply
29	GND	Ground		Ground
30	PMIC_EN	I	EN(PMIC)	Enable build-in PMIC. Logic high enables internal regulators and internal hardware reset is de- asserted. Logic low disables regulators and internal hardware reset is asserted. <b>Do not float this pin</b>
31	GPIO[21]	I/O	GPIO[21]	Programmable GPIO
			PCIE_PERSTn	PCIe host indication to reset the device (input) (active low)
32	PCIE_WAKE_N	I/O	PCIE_WAKEn	PCIe wake signal (active low)
33	GPIO[5] (BT_PCM_DOUT)	I/O	GPIO[5]	Programmable GPIO
			PCM_DOUT	PCM Data
34	NC			No Connect
35	NC			No Connect
36	GND	Ground		Ground
37	GND	Ground		Ground
38	GND	Ground		Ground
39	PCIE_RXP	I	PCIE_RX_P	PCI Express Lane 0, Receive Pair, Positive Signal 2.5 GHz serial low- voltage interface
			USB3_RX_P	USB 3.0 receive data - positive

No.	Pin name	Type	Connection to IC Pin Name <sup>1</sup>	Description
40	PCIE_RXN	O	PCIE_RX_N	PCI Express Lane 0, Receive Pair, Negative Signal 2.5 GHz serial low-voltage interface
			USB3_RX_N	USB 3.0 receive data - negative
41	PCIE_TXP	O	PCIE_TX_P	PCI Express Lane 0, Transmit Pair, Positive Signal 2.5 GHz serial low-voltage interface
			USB3_TX_P	USB3.0 transmit data - positive
42	PCIE_TXN	O	PCIE_TX_N	PCI Express Lane 0, Transmit Pair, Negative Signal 2.5 GHz serial low-voltage interface
			USB3_TX_N	USB3.0 transmit data - negative
43	PCIE_CLKP	I	PCIE_RCLK_P	PCI Express Platform Reference Clock Positive signal of differential pair 100 MHz low-voltage interface
44	PCIE_CLKN	I	PCIE_RCLK_N	PCI Express Platform Reference Clock Negative signal of differential pair 100 MHz low-voltage interface
45	GND	Ground		Ground
46	GPIO[4] (BT_PCM_DIN)	I/O	GPIO[4]	Programmable GPIO
		I	PCM_DIN	PCM Data
47	GPIO[0]	I/O	GPIO[0]	Programmable GPIO Oscillator Mode: XOSC_EN/CLK_REQ(output)(active high) 0 = disable external oscillator 1 = enable external oscillator *Internal Pull-up
48	DNC		DNC	Do Not Connect
49	DNC		DNC	Do Not Connect
50	AVDD18	O	VLDO(PMIC)	LDO Output. Use for CONFIG_HOST pull-up.
51	DNC	DNC	DNC	Do Not Connect
52	CONFIG_HOST_3		CONFIG_HOST[3]	Configuration interface[3] See <a href="#">Section 4.2</a> 
53	CONFIG_HOST_2		CONFIG_HOST[2]	Configuration interface[2] See <a href="#">Section 4.2</a> 
54	CONFIG_HOST_1		CONFIG_HOST[1]	Configuration interface[1] See <a href="#">Section 4.2</a> 
55	CONFIG_HOST_0		CONFIG_HOST[0]	Configuration interface[0] See <a href="#">Section 4.2</a> 
56	SLP_CLK	I	SLP_CLK_IN	<b>Sleep Clock Input</b> Used for WLAN and Bluetooth low power modes. If no sleep clock input is provided, an internal sleep clock (derived from reference clock) will be used. if SLP_CLK is not connected, the internal circuit will detect no signal, and firmware will initialize the sleep clock based on the reference clock.



No.	Pin name	Type	Connection to IC Pin Name <sup>1</sup>	Description
57	GND	Ground		Ground
58	GND	Ground		Ground
59	WLAN_RF_A	I/O	RF_TR_2_A RF_TR_5_A	RF Transmit / Receive (2.4G/5 GHz) - PathA
60	GND	Ground		Ground
61	GPIO[6] (BT_PCM_CLK)	I/O	GPIO[6]	Programmable GPIO
		I/O	PCM_CLK	PCM Clock Signal Output if PCM master. Input if PCM slave.
		O	PCM_MCLK	PCM Clock Signal (optional) Optional clock used for some codecs. Derived from PCM_CLK.
62	GPIO[9] (BT_UART_RXD)	I/O	GPIO[9]	Programmable GPIO
		I	UART_SIN	Serial data Input from modem, data set, or peripheral device.
63	GPIO[8] (BT_UART_TXD)	I/O	GPIO[8]	Programmable GPIO
		O	UART_SOUT	Serial data Output to modem, data set, or peripheral device.
64	GPIO[13] (BT_WAKEUP_HOST) <sup>2</sup>	I/O	GPIO[13]	Programmable GPIO
		O	UART_DTRn	Data Terminal Ready Output to modem, data set, or peripheral device (active low).
65	GPIO[10] (BT_UART_CTSn)	I/O	GPIO[10]	Programmable GPIO
		I	UART_CTSn	Clear To Send Input from modem, data set, or peripheral device (active low).
66	GPIO[11] (BT_UART_RTSn)	I/O	GPIO[11]	Programmable GPIO
		O	UART_RTSn	Request To Send Output to modem, data set, or peripheral device (active low).
67	GPIO[12] (HOST_WAKEUP_BT) <sup>2</sup>	I/O	GPIO[12]	Programmable GPIO
		I	UART_DSRn	Data Set Ready Input from modem, data set, or peripheral device (active low).
68	GND	Ground		Ground
69	WLAN_RF_B	I/O	RF_TR_2_A RF_TR_5_A	RF Transmit / Receive (2.4G/5 GHz) - PathB
70	GND	Ground		Ground
71	GPIO[26]	I/O	GPIO[26]	Programmable GPIO
72	GPIO[27]	I/O	GPIO[27]	Programmable GPIO
73	NC (GPIO[18])	I/O	GPIO[18] DVS0(PMIC)	NC
74	GND	Ground		Ground
75	VBAT	Power	PVIN(PMIC)	Power Supply
76	VBAT	Power	PVIN(PMIC)	Power Supply
77	GND	Ground		Ground
78	GPIO[1] (USB_VBUS_ON)	I/O	GPIO[1]	Programmable GPIO

No.	Pin name	Type	Connection to IC Pin Name <sup>1</sup>	Description
79	GPIO[23]	I/O	GPIO[23]	Programmable GPIO
80	GPIO[22]	I/O	GPIO[22]	Programmable GPIO
			PCIE_W_DISABLEn	PCIe host indication to disable the WLAN function of the device (input) (active low)
81	GPIO[7] (BT_PCM_SYNC)	I/O	GPIO[7]	Programmable GPIO
		I/O	PCM_SYNC	PCM Sync Pulse Signal Output if PCM master. Input if PCM slave.
82	PCIE_CLKREQ_N	I/O	PCIE_CLKRQn	PCI Express Wake Signal
83	NC			No Connect
84-120	GND	Ground		Ground

## 7.3 Configuration Pins

**Table 8** shows the configuration pins for Type 1YM.

**Table 8: Configuration Pins**

Configuration Bits	Pin Name	Configuration Function
CON[2]	CONFIG_HOST[2]	Firmware Boot Options No hardware impacts. Software reads and boots accordingly. See <b>Table 9</b> .
CON[1]	CONFIG_HOST[1]	
CON[0]	CONFIG_HOST[0]	

**Table 9** shows the firmware download modes.

**Table 9: Firmware Download Mode**

Strap Value	WLAN	Bluetooth/BLE	ROM Notes	Firmware Download Mode	Number of SDIO Functions
000	SDIO	UART		Parallel	1 (WLAN)
001	SDIO	SDIO		Parallel	2 (WLAN, Bluetooth)
010	PCIe	USB 2.0	Initialize USB 2.0 PHY and COM PHY PCIe portion	Parallel	
011	PCIe	UART	Initialize only COM PHY PCIe portion	Parallel	
100	USB 3.0/2.0	UART	Initialize both COM PHY USB 3.0 and USB 2.0 PHY	Parallel	
101	USB 2.0	USB 2.0	Initialize only USB 2.0 PHY	Parallel	
110	USB 3.0/2.0	USB 3.0/2.0	Initialize both COM PHY USB 3.0 and USB 2.0 PHY	Parallel	
111	USB3.0	USB 3.0	Initialize only COM PHY USB 3.0 portion	Parallel	



WLAN-USB, BT-SDIO, and BT-USB interfaces may not be supported.  
Refer to [Type 1YM webpage](#) or check [1YM Community Forum](#).



AVDD18 output can be used to pull-up CONFIG\_HOST pins.

## 7.4 Pin States

Pin states information for the tables below include:

- After firmware is downloaded, the pads (GPIO, Serial interface, RF control) are programmed in functional mode per the functionality of the pins.
- For SDIO, once the command is received from the host, the pads are configured accordingly.
- Pull-up and pull-down are only effective when the pad is in input mode.
- The power-down state shown is the default configuration. Many pads have programmable power-down values, which can be set by firmware.
- Do not need any termination to the open pins in input mode that have an Internal Pull-up/Pull-down resistor (PU/PD). Do not need any termination to the open pins in output mode. Do not need any termination to PCIE signals, Pin 13 and Pin 14 in SDIO mode.

**Table 10: I/O State Table**

Pin Name	Supply	No Pad Power State	Reset State	HW State <sup>3</sup>	PD State <sup>4</sup>	PD Prog <sup>5</sup>	Internal PU/PD	Int'l Pull Value[Ω]
GPIO[0]	VIO	tristate	output	output	drive low	yes	nominal PU	90K
GPIO[1]	VIO	tristate	input	input	tristate	yes	nominal PU	90K
GPIO[2]	VIO	tristate	input	input	tristate	yes	nominal PU	90K
GPIO[3]	VIO	tristate	input	input	tristate	yes	nominal PU	90K
GPIO[4]	VIO	tristate	input	input	tristate	yes	nominal PU	90K
GPIO[5]	VIO	tristate	input	input	tristate	yes	nominal PU	90K
GPIO[6]	VIO	tristate	input	input	tristate	yes	nominal PU	90K
GPIO[7]	VIO	tristate	input	input	tristate	yes	nominal PU	90K
GPIO[8]	VIO	tristate	input	input	drive low	yes	weak PU	800K
GPIO[9]	VIO	tristate	input	input	tristate	yes	weak PU	800K
GPIO[10]	VIO	tristate	input	input	tristate	yes	nominal PU	90K
GPIO[11]	VIO	tristate	input	input	drive high	yes	weak PU	800K
GPIO[12]	VIO	tristate	input	input	tristate	yes	nominal PD	90K
GPIO[13]	VIO	tristate	input	input	drive high	yes	nominal PU	90K
GPIO[14]	VIO	tristate	input	input	tristate	yes	nominal PU	90K
GPIO[15]	VIO	tristate	input	input	tristate	yes	nominal PU	90K
GPIO[16]	VIO	tristate	input	input	tristate	yes	nominal PD	90K
GPIO[17]	VIO	tristate	input	input	tristate	yes	nominal PD	90K
GPIO[18]	VIO	tristate	input	input	tristate	yes	nominal PD	90K

<sup>3</sup> Hardware default state after reset

<sup>4</sup> Power-down state

<sup>5</sup> Power-down state programmable

Pin Name	Supply	No Pad Power State	Reset State	HW State <sup>3</sup>	PD State <sup>4</sup>	PD Prog <sup>5</sup>	Internal PU/PD	Int'l Pull Value[Ω]
GPIO[19]	VIO	tristate	input	input	tristate	yes	nominal PU	90K
GPIO[20]	VIO	tristate	input	input	tristate	yes	nominal PU	90K
GPIO[21]	VIO	tristate	input	input	tristate	yes	nominal PU	90K
GPIO[22]	VIO	tristate	input	input	tristate	yes	nominal PU	90K
GPIO[23]	VIO	tristate	input	input	tristate	yes	nominal PU	90K
GPIO[24]	VIO	tristate	input	input	tristate	yes	nominal PU	90K
GPIO[25]	VIO	tristate	input	input	drive high	yes	nominal PU	90K
GPIO[26]	VIO	tristate	input	input	tristate	yes	nominal PU	90K
GPIO[27]	VIO	tristate	input	input	tristate	yes	nominal PU	90K
SD_CLK	VIO_SD	tristate	input	input	tristate	no	nominal PU	90K
SD_CMD	VIO_SD	tristate	input	input	tristate	no	nominal PU	90K
SD_D0	VIO_SD	tristate	input	input	tristate	no	nominal PU	90K
SD_D1	VIO_SD	tristate	input	input	tristate	no	nominal PU	90K
SD_D2	VIO_SD	tristate	input	input	tristate	no	nominal PU	90K
SD_D3	VIO_SD	tristate	input	input	tristate	no	nominal PU	90K
PCIE_CLKP	AVDD18							
PCIE_CLKN	AVDD18							
PCIE_TXP	AVDD18							
PCIE_TXN	AVDD18							
PCIE_RXP	AVDD18							
PCIE_RXN	AVDD18							
PCIE_WAKE_N	VIO	tristate	input	output	N/A	N/A	N/A	
PCIE_CLKREQ_N	VIO	tristate	input	output	N/A	N/A	N/A	
CONFIG_HOST_0	AVDD18	tristate	input	input	tristate	no	weak PU	800K
CONFIG_HOST_1	AVDD18	tristate	input	input	tristate	no	weak PU	800K
CONFIG_HOST_2	AVDD18	tristate	input	input	tristate	no	weak PU	800K
CONFIG_HOST_3	AVDD18	tristate	input	input	tristate	no	weak PU	800K
SLP_CLK_IN	VIO	tristate	input <sup>6</sup>	input	tristate	no	nominal PU	90K

## 8 Absolute Maximum Ratings

The absolute maximum ratings are shown in **Table 11**.

**Table 11: Absolute and Maximum Ratings**

Parameter		Minimum	Maximum	Unit	
Storage Temperature		-30	+85	°C	
Supply Voltage	VBAT		6.0	V	
	VIO		2.2	V	
				3.0	V
				4.0	V

<sup>6</sup> Input mode after reset

Parameter		Minimum	Maximum	Unit
	VIO_SD		2.2	V
			4.0	V
	AVDD33		4.0	V



Stresses in excess of the absolute ratings may cause permanent damage. Functional operation is not implied under these conditions. Exposure to absolute ratings for extended periods of time may adversely affect reliability. No damage assuming only one parameter is set at limit at a time with all other parameters are set within operating condition.

## 9 Operating Conditions

This section describes the operating conditions and external sleep clock requirements.

### 9.1 Operating Conditions

The operating conditions are shown in **Table 12**.

**Table 12: Operating Conditions**

Parameter		Minimum	Typical	Maximum	Unit
Operating Temperature	Ta	-30		+85	°C
	Tj			+125	°C
Operating Voltage	VBAT	2.7		5.5	V
	VIO	1.62	1.8	1.98	V
		2.25	2.5	2.75	V
		2.97	3.3	3.47	V
	VIO_SD	1.62	1.8	1.98	V
		2.97	3.3	3.47	V
AVDD33 <sup>7</sup>	2.97	3.3	3.63	V	
IO Current	VIO & VIO_SD		0.2	0.6	mA
Peak Current <sup>8</sup>	VBAT		1.0	1.3	A



Operation beyond the recommended operating conditions is neither recommended nor guaranteed.

<sup>7</sup> AVDD33 is used for only when USB interface is used.

<sup>8</sup> Peak current of VBAT (RF portion) is happen during DPD calibration when the firmware is downloaded.

## 9.2 External Sleep Clock Requirements

Table 13 shows the external sleep clock requirements of Type 1YM.

Table 13: External Sleep Clock Requirements

Symbol	Parameter	Minimum	Typical	Maximum	Unit
CLK	Clock frequency range/accuracy: <ul style="list-style-type: none"> <li>• CMOS input clock signal type</li> <li>• <math>\pm 250</math> ppm (initial, aging, temperature)</li> </ul>		32.768		kHz
V <sub>IH</sub>	Input levels, where V <sub>IO</sub> = 1.8, 2.5, 3.3 V	0.7*V <sub>IO</sub>		V <sub>IO</sub> +0.4	V
V <sub>IL</sub>		-0.4		0.3*V <sub>IO</sub>	V
PN	Phase noise requirement (@ 100 kHz)		-125		dBc/Hz
J <sub>c</sub>	Cycle jitter		1.5		ns (RMS)
SR	Slew rate limit (10-90%)			100	ns
DC	Duty cycle tolerance	20		80	%



Voltage input levels = 1.8V or 3.3V

## 9.3 Digital I/O Requirements

Table 14 shows the digital I/O requirements of Type 1YM.

Table 14: Digital I/O Requirements Parameters

Symbol	Parameter	Condition	Minimum	Typical	Maximum	Unit
V <sub>IH</sub>	Input high voltage		0.7*V <sub>IO</sub>		V <sub>IO</sub> +0.4	V
V <sub>IL</sub>	Input low voltage		-0.4		0.3*V <sub>IO</sub>	V
V <sub>HYS</sub>	Input hysteresis		100			mV
V <sub>OH</sub>	Output high voltage		V <sub>IO</sub> -0.4			V
V <sub>OL</sub>	Output low voltage				0.4	V

## 9.4 Package Thermal Conditions

The package thermal conditions are as below:

- $R\Psi_{jt}$  : 3.2°C/W
- $R\Psi_{jt} = (T_j - T_t)/P$



T<sub>j</sub>: Junction temperature (°C), T<sub>t</sub>: Top temperature (°C), P: Total Power Consumption (W)

Figure 4: Package Thermal Conditions

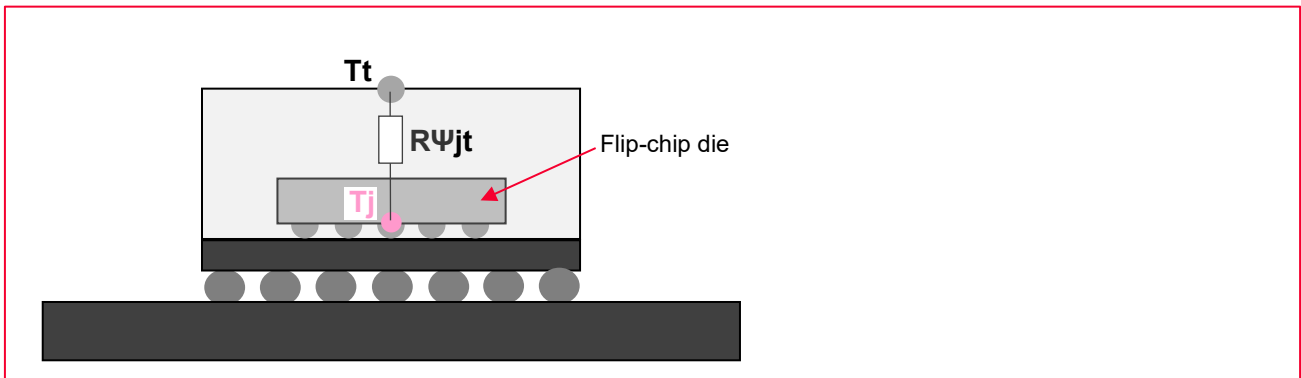

## 10 Power Sequence

This section describes the power-on and power-off sequences along with their parameters.

### 10.1 Power-On Sequence

- VBAT and VIO must be good (90%) at the same time or before assert PMIC\_EN (= 0 to 1).
- Rump-up time of VIO must be < 100 ms

Figure 5: Power-On Sequence Graph

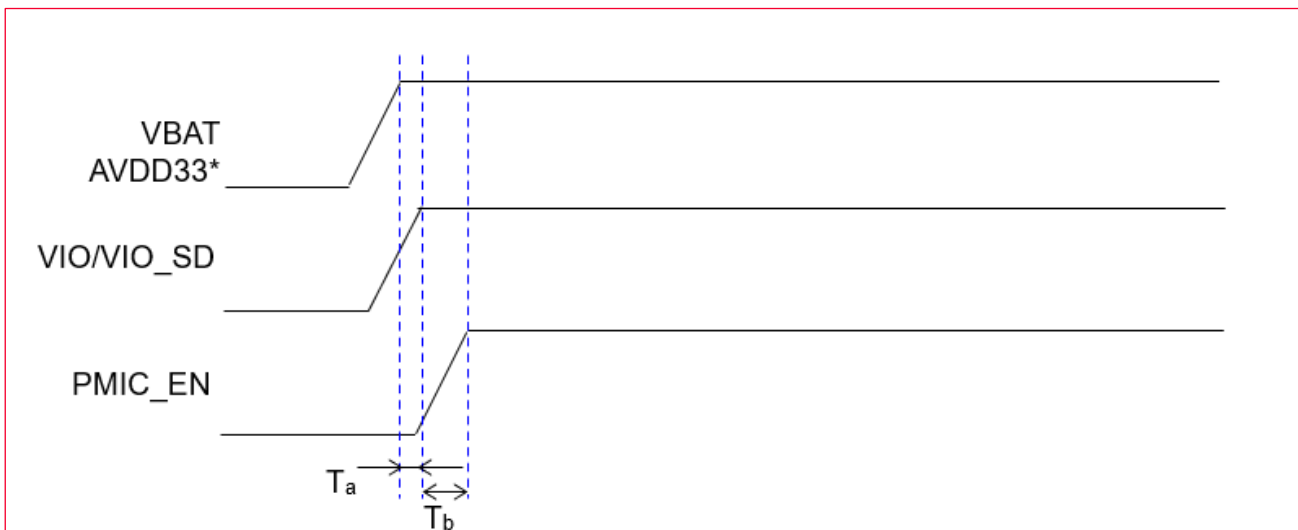

AVDD33 is used for only when USB interface is used.

Table 15: Parameters for Power-On Sequence

Symbol	Parameter	Minimum	Typical	Maximum	Unit
Ta	VBAT/AVDD33 to VIO time	0			ms
Tb	VIO to PMIC_EN time	0			ms

## 10.2 Power-Off Sequence

- VBAT and VIO must be down at the same time or before de-assert PMIC\_EN (= 1 to 0).
- Rump-down time of VIO must be < 100 ms

Figure 6: Power-Off Sequence Graph

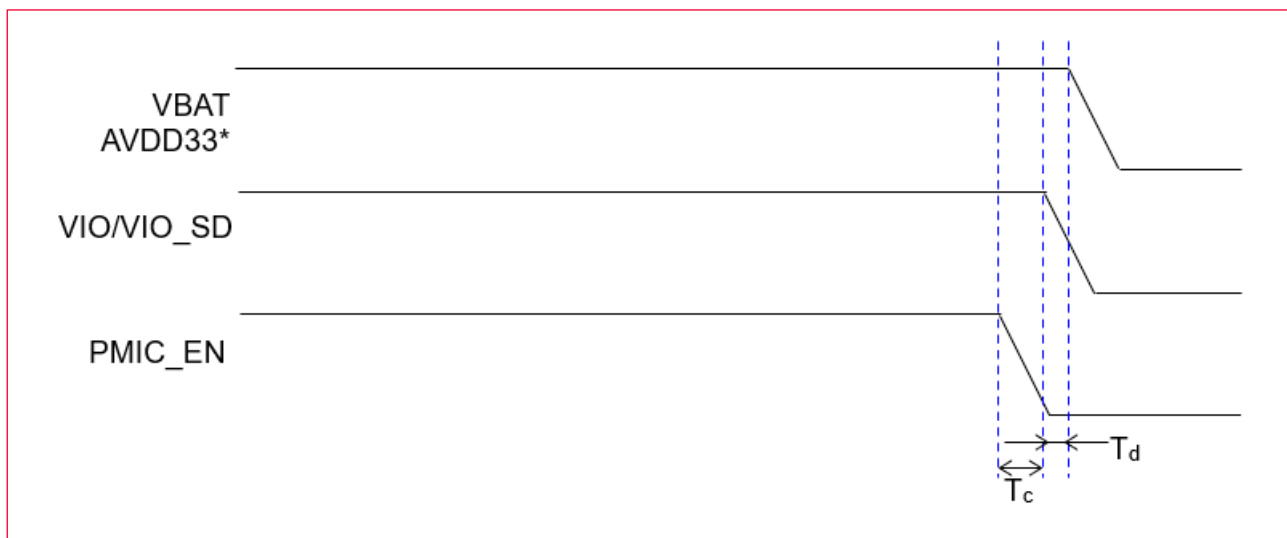

AVDD33 is used for only when USB interface is used.

Table 16: Parameters for Power-Off Sequence

Symbol	Parameter	Minimum	Typical	Maximum	Unit
Tc	PMIC_EN to VIO time	0			ms
Td	VIO to VBAT/AVDD33 time	0			ms



# 11 Host Interface Specification

This section describes the SDIO specification, its speed modes, related parameters, and graphs.

## 11.1 SDIO Specifications

- The SDIO host interface pins are powered from the VIO\_SD voltage supply.
- The SDIO electrical specifications are identical for 4-bit SDIO and 1-bit SDIO transfer modes.

### 11.1.1 Default Speed, High Speed Modes

Figure 7 shows the default mode signals.

Figure 7: SDIO Protocol Timing Diagram - Default Speed Mode (3.3V)

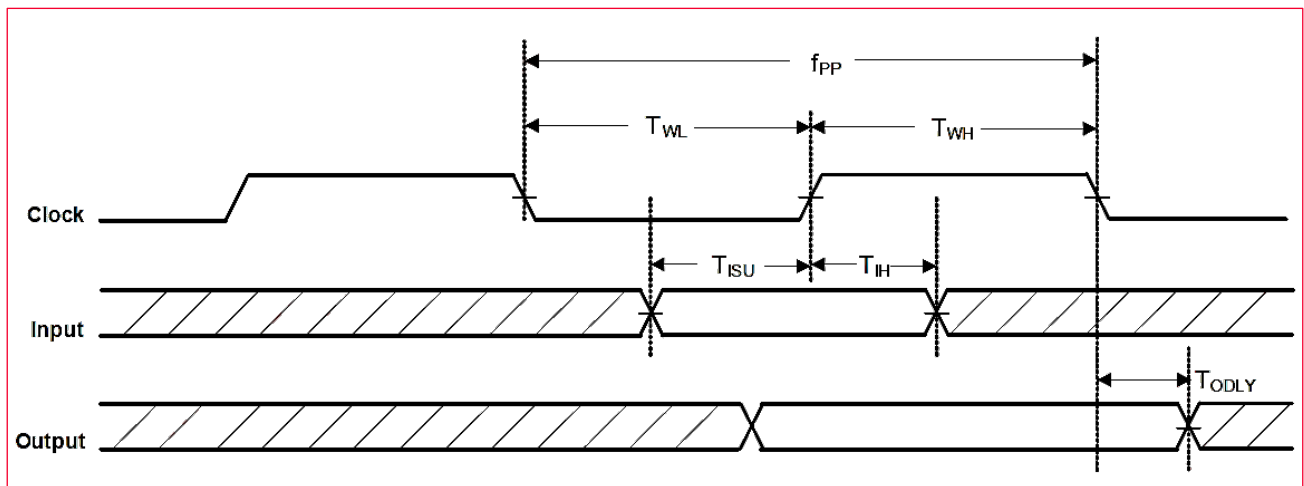
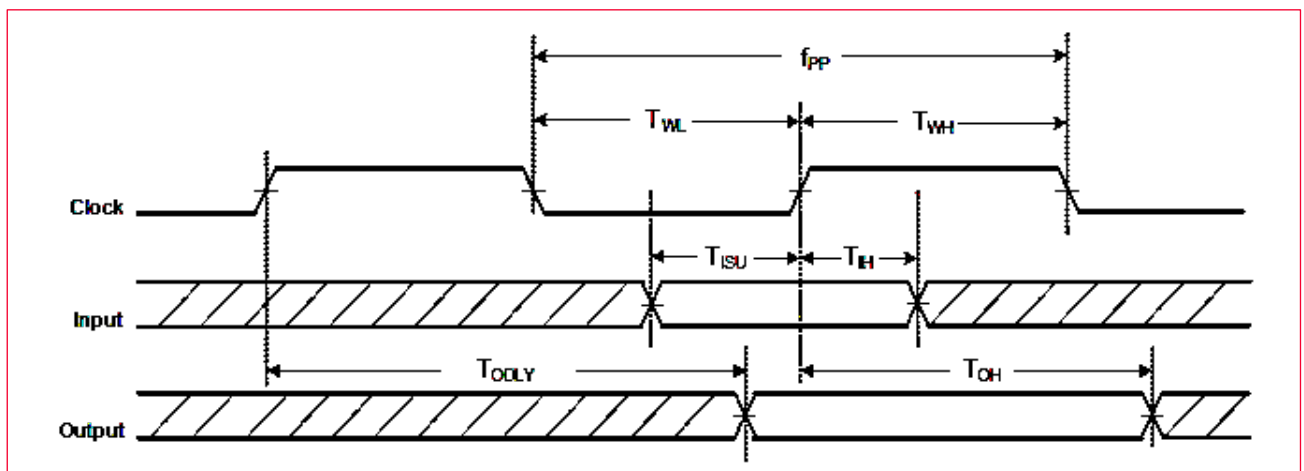

Figure 8 shows the high speed mode signals.

Figure 8: SDIO Protocol Timing Diagram - High Speed Mode (3.3V)



**Table 17** lists the SDIO timing data for high speed mode.

**Table 17: SDIO Timing Data - Default Speed, High Speed Modes (3.3V)**

Symbol	Parameter	Condition	Minimum	Typical	Maximum	Units
f <sub>PP</sub>	Clock frequency	Normal	0		25	MHz
		High speed	0		50	MHz
T <sub>WL</sub>	Clock low time	Normal	10			ns
		High speed	7			ns
T <sub>WH</sub>	Clock high time	Normal	10			ns
		High speed	7			ns
T <sub>ISU</sub>	Input setup time	Normal	5			ns
		High speed	6			ns
T <sub>IH</sub>	Input hold time	Normal	5			ns
		High speed	2	-	-	ns
T <sub>ODLY</sub>	Output delay time	Normal	-	-	14	ns
	C <sub>L</sub> ≤ 40 pF (1 card)	High speed	-	-	14	ns
T <sub>OH</sub>	Output hold time	High speed	2.5	-	-	ns



Over full range of values specified in the Recommended Operating Conditions unless otherwise specified.

### 11.1.2 SDR12, SDR25, SDR50 Modes up to 100 MHz (1.8 V)

**Figure 9** shows the SDIO protocol diagram for SDR12, SDR25, SDR50 Modes (up to 100 MHz & 1.8 V).

**Figure 9: SDIO Protocol Timing Diagram - SDR12, SDR25, SDR50 Modes**

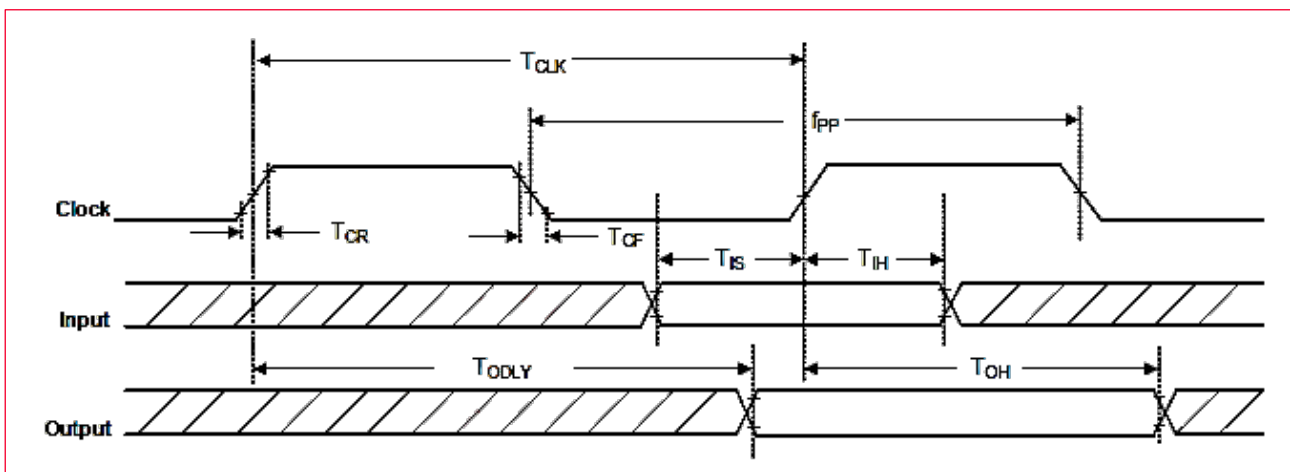

**Table 18: SDIO Timing Data - SDR12, SDR25, SDR50 Modes**

Symbol	Parameter	Condition	Minimum	Typical	Maximum	Unit
f <sub>PP</sub>	Clock frequency	SDR12/25/50	25		100	MHz
T <sub>IS</sub>	Input setup time	SDR12/25/50	3			ns
T <sub>IH</sub>	Input hold time	SDR12/25/50	0.8			ns
T <sub>CLK</sub>	Clock time	SDR12/25/50	10		40	ns
T <sub>CR, TCF</sub>	Rise time, fall time T <sub>CR</sub> , T <sub>CF</sub> < 2 ns(maximum) at 100 MHz C <sub>CARD</sub> = 10 pF	SDR12/25/50			0.2*T <sub>CLK</sub>	ns
T <sub>ODLY</sub>	Output delay time C <sub>L</sub> ≤ 30 pF	SDR12/25/50			7.5	ns
T <sub>OH</sub>	Output hold time C <sub>L</sub> = 15 pF	SDR12/25/50	1.5			ns



Over full range of values specified in the Recommended Operating Conditions unless otherwise specified.

### 11.1.3 SDR104 Mode at 208 MHz (1.8 V)

**Figure 10** shows the SDIO protocol timing diagram for SDR104 Mode (208 MHz & 1.8V).

**Figure 10: SDIO Protocol Timing Diagram - SDR104 Mode**

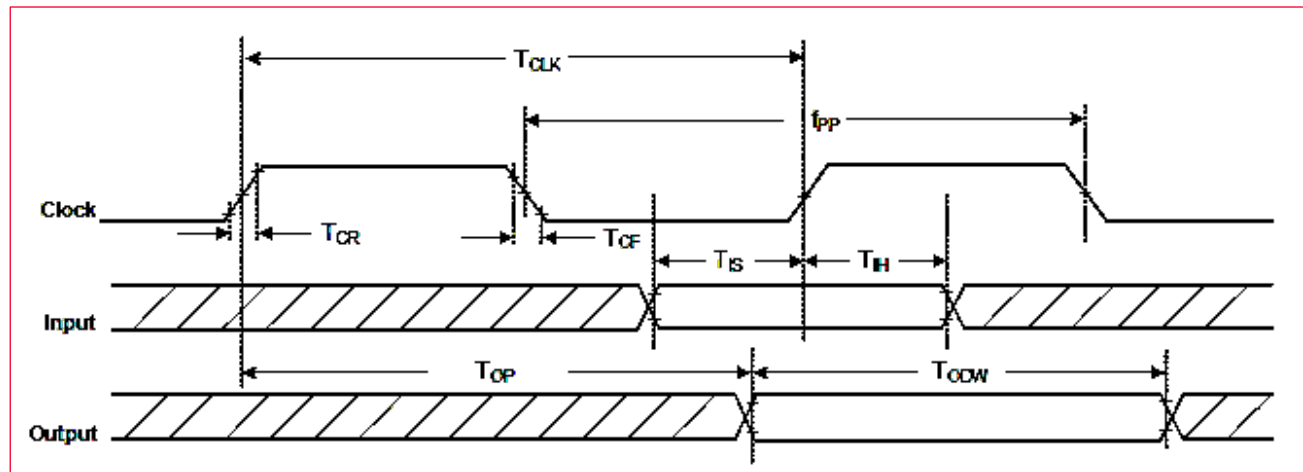

**Table 19** shows the SDIO timing data parameters for SDR104 Mode (208 MHz).

**Table 19: SDIO Timing Data - SDR104 Mode**

Symbol	Parameter	Condition	Minimum	Typical	Maximum	Unit
f <sub>PP</sub>	Clock frequency	SDR104	0		208	MHz
T <sub>IS</sub>	Input setup time	SDR104	1.4			ns
T <sub>IH</sub>	Input hold time	SDR104	0.8			ns
T <sub>CLK</sub>	Clock time	SDR104	4.8			ns

Symbol	Parameter	Condition	Minimum	Typical	Maximum	Unit
$T_{CR}, T_{CF}$	Rise time, fall time $T_{CR}, T_{CF} < 0.96$ ns(maximum) at 208 MHz $C_{CARD} = 10$ pF	SDR104			$0.2 \cdot T_{CLK}$	ns
$T_{OP}$	Card output phase	SDR104	0		10	ns
$T_{ODW}$	Output timing of variable data window	SDR104	2.88			ns



Over full range of values specified in the Recommended Operating Conditions unless otherwise specified.

### 11.1.4 DDR50 Mode at 50 MHz (1.8 V)

Figure 11 shows SDIO CMD timing diagram for DDR50 Mode (50 MHz & 1.8V).

Figure 11: SDIO CMD Timing Diagram - DDR50 Mode

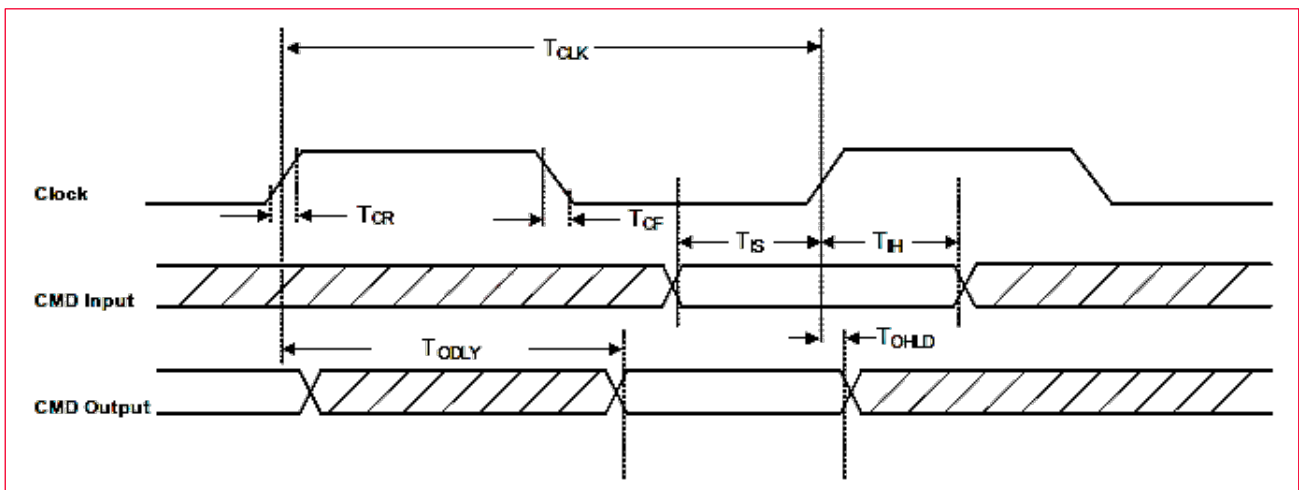

Figure 12 shows SDIO DAT[3:0] timing diagram for DDR50 Mode (50 MHz & 1.8V).

Figure 12: SDIO DAT[3:0] Timing Diagram - DDR50 Mode

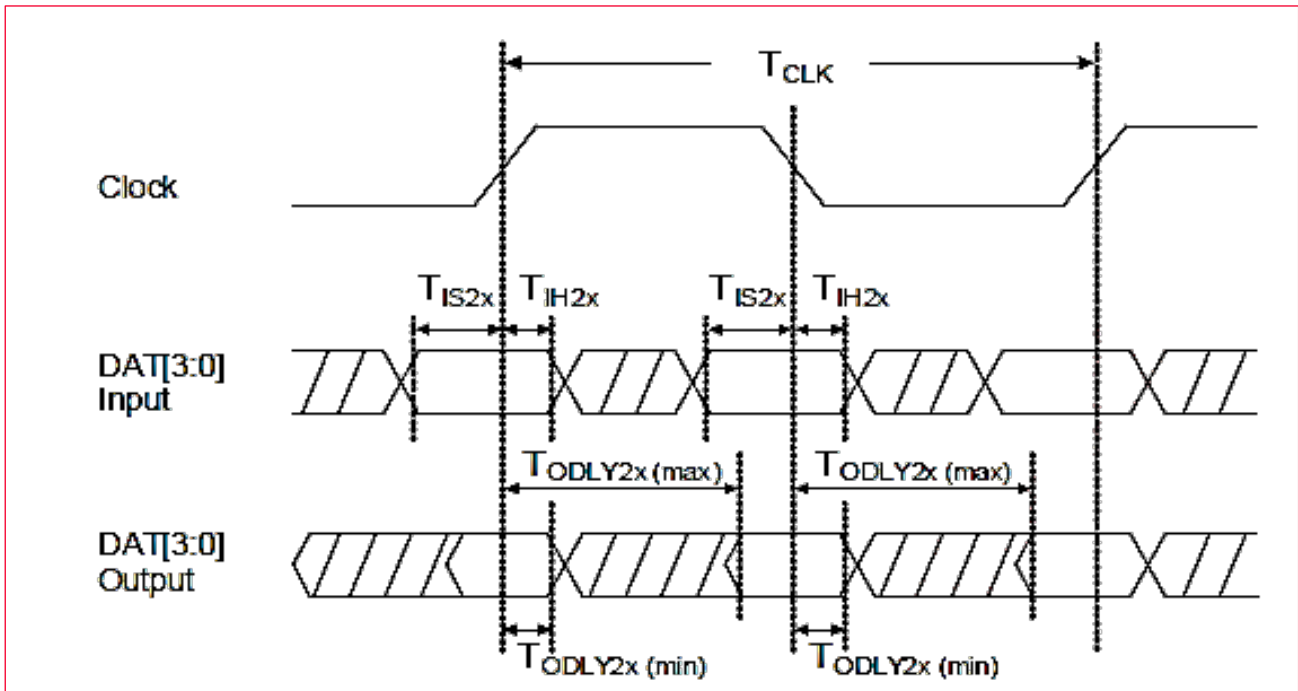

Table 20: SDIO Timing Data - DDR50 Mode (50 MHz)

Symbol	Parameter	Condition	Minimum	Typical	Maximum	Unit
<b>Clock</b>						
$T_{CLK}$	Clock time 50 MHz (maximum) between rising edges	DDR50	20			ns
$T_{CR}, T_{CF}$	Rise time, fall time $T_{CR}, T_{CF} < 4.00$ ns (maximum) at 50 MHz $C_{CARD} = 10$ pF	DDR50			$0.2 * T_{CLK}$	ns
Clock Duty		DDR50	45		55	%
<b>CMD Input (referenced to clock rising edge)</b>						
$T_{IS}$	Input setup time $C_{CARD} \leq 10$ pF (1 card)	DDR50	6			ns
$T_{IH}$	Input hold time $C_{CARD} \leq 10$ pF (1 card)	DDR50	0.8			ns
<b>CMD Output (referenced to clock rising edge)</b>						
$T_{ODLY}$	Output delay time during data transfer mode $C_L \leq 30$ pF (1 card)	DDR50			13.7	ns
$T_{OHL D}$	Output hold time $C_L \geq 15$ pF (1 card)	DDR50	1.5			ns
<b>DAT [3:0] Input (referenced to clock rising and falling edges)</b>						
$T_{IS2x}$	Input setup time $C_{CARD} \leq 10$ pF (1 card)	DDR50	3			ns
$T_{IH2x}$	Input hold time	DDR50	0.8			ns

Symbol	Parameter	Condition	Minimum	Typical	Maximum	Unit
	$C_{CARD} \leq 10 \text{ pF}$ (1 card)					
<b>DAT [3:0] Output (referenced to clock rising and falling edges)</b>						
$T_{ODLY2x (max)}$	Output delay time during data transfer mode $C_L \leq 25 \text{ pF}$ (1 card)	DDR50			7.0	ns
$T_{ODLY2x (min)}$	Output hold time $C_L \geq 15 \text{ pF}$ (1 card)	DDR50	1.5			ns



Over full range of values specified in the Recommended Operating Conditions unless otherwise specified.

## 11.2 PCI Express Specifications

The PCI Express host interface pins are powered from the AVDD18 voltage supply.

### 11.2.1 Differential Tx Output Electricals

This section describes the Tx output electricals.

#### 11.2.1.1 PCI Express Tx Output Specifications Data - 2.5 GT/s

Specifications for Differential Tx Output Electricals is shown in **Table 21**.



This specification is in accordance with PCI Express Base Specification, Revision 2.1 March 4, 2009.

**Table 21: PCI Express Tx Output Specifications Data - 2.5 GT/s**

Symbol	Parameter	Minimum	Typical	Maximum	Unit
UI	Unit Interval (UI) The specified UI is equivalent to a tolerance of $\pm 300$ ppm for each Refclk source. Period does not account for SSC induced variations.	399.88		400.12	ps
V <sub>TX-DIFF-PP</sub>	Differential peak-to-peak Tx voltage swing $V_{TX-DIFF-PP} = 2 *  V_{TXD+} - V_{TXD-} $	0.8		1.2	V
V <sub>TX-DIFF-PP-LOW</sub>	Low power differential peak-to-peak tTx voltage swing $V_{TX-DIFF-PP} = 2 *  V_{TXD+} - V_{TXD-} $	0.4		1.2	V
V <sub>TX-DE-RATIO-3.5dB</sub>	Tx de-emphasis level ratio (3.5 dB)	3.0		4.0	dB
T <sub>TX-EYE</sub>	Tx eye including all jitter sources	0.75		-	UI
T <sub>TX-EYE-MEDIAN-to-MAX-JITTER</sub>	Maximum time between jitter median and maximum deviation from median.			0.125	UI
T <sub>TX-RISE-FALL</sub>	Tx rise/fall time. Measured differentially from 20% to 80% of swing.	0.125			UI
RL <sub>TX-DIFF</sub>	Tx package plus Si differential return loss	10			dB
RL <sub>TX-CM</sub>	Tx package plus Si common mode return loss	6			dB
V <sub>TX-CM-AC-P</sub>	Tx AC common mode voltage.		20		mV
I <sub>TX-SHORT</sub>	Tx short circuit current limit			90	mA
V <sub>TX-DC-CM</sub>	Tx DC common mode voltage	0		3.6	V
V <sub>TX-CM-DC-ACTIVE-IDLE-DELTA</sub>	Absolute delta of DC common mode voltage during L0 and electrical idle.	0		100	mV
V <sub>TX-IDLE-DIFF-AC-P</sub>	Electrical idle differential peak output voltage.	0		20	mV
V <sub>TX-RCV-DETECT</sub>	Voltage change allowed during receiver detection.			600	mV
T <sub>TX-IDLE-MIN</sub>	Minimum time spent in electrical idle	20			ns

Symbol	Parameter	Minimum	Typical	Maximum	Unit
T <sub>TX-IDLE-SET-TO-IDLE</sub>	Maximum time to transition to a valid electrical idle after sending an electrical idle ordered set			8	ns
T <sub>TX-IDLE-TO-DIFF-DATA</sub>	Maximum time to transition to valid diff signaling after leaving electrical idle			8	ns
T <sub>CROSSLINK</sub>	Crosslink random timeout			1.0	ms
C <sub>TX</sub>	AC coupling capacitor	75		200	nF

### 11.2.1.2 PCI Express Tx Output Specifications Data - 5 GT/s

PCI Express Tx Output Specifications Data for 5 GT/s is shown in **Table 22**.



This specification is in accordance with PCI Express Base Specification, Revision 2.1 March 4, 2009.

**Table 22: PCI Express Tx Output Specifications Data - 5 GT/s**

Symbol	Parameter	Minimum	Typical	Maximum	Unit
UI	Unit Interval (UI) The specified UI is equivalent to a tolerance of $\pm 300$ ppm for each Refclk source. Period does not account for SSC induced variations.	199.94		200.06	ps
V <sub>TX-DIFF-PP</sub>	Differential peak-to-peak Tx voltage swing $V_{TX-DIFF-PP} = 2 *  V_{TXD+} - V_{TXD-} $	0.8		1.2	V
V <sub>TX-DIFF-PP-LOW</sub>	Low power differential peak-to-peak Tx voltage swing $V_{TX-DIFF-PP} = 2 *  V_{TXD+} - V_{TXD-} $	0.4		1.2	V
V <sub>TX-DE-RATIO-3.5dB</sub>	Tx de-emphasis level ratio (3.5 dB)	3.0		4.0	dB
V <sub>TX-DE-RATIO-6dB</sub>	Tx de-emphasis level ratio (6 dB)	5.5		6.5	dB
T <sub>MIN-PULSE</sub>	Instantaneous lone pulse width. Measured relative to rising/falling pulse.	0.9			UI
T <sub>TX-EYE</sub>	Tx eye including all jitter sources	0.75			UI
T <sub>TX-HF-DJ-DD</sub>	Tx deterministic jitter > 1.5 MHz Deterministic jitter only.			0.15	UI
T <sub>TX-LF-RMS</sub>	Tx RMS jitter < 1.5 MHz Total energy measured over a 10 kHz—1.5 MHz range		3.0		Ps RMS
T <sub>TX-RISE-FALL</sub>	Tx rise/fall time Measured differentially from 20% to 80% of swing	0.15			UI
R <sub>LTX-DIFF</sub>	Tx package plus Si differential return loss (1.25-2.5 GHz)	10			dB
	Tx package plus Si differential return loss (0.05-1.25 GHz)	8			
R <sub>LTX-CM</sub>	Tx package plus Si common mode return loss	6			dB
V <sub>TX-CM-AC-PP</sub>	Tx AC common mode voltage			100	mVPP
I <sub>TX-SHORT</sub>	Tx short circuit current limit	0		90	mA
V <sub>TX-DC-CM</sub>	Tx DC common mode voltage	0		3.6	V
V <sub>TX-CM-DC-ACTIVE-IDLE-DELTA</sub>	Absolute delta of DC common mode voltage during L0 and electrical idle.	0		100	mV
V <sub>TX-IDLE-DIFF-AC-P</sub>	Electrical idle differential peak output voltage $V_{TX-IDLE-DIFF-DC} =  V_{TX-IDle-D+} - V_{TX-IDle-D-}  \leq 20$ mV	0		20	mV
V <sub>TX-IDLE-DIFF-DC</sub>	DC Electrical idle differential peak output voltage	0		5	mV



Symbol	Parameter	Minimum	Typical	Maximum	Unit
	$V_{TX-IDLE-DIFF-DC} =  V_{TX-IDLE-D+} - V_{TX-IDLE-D-}  \leq 5 \text{ mV}$				
$V_{TX-RCV-DETECT}$	Voltage change allowed during receiver detection.			600	mV
$T_{TX-IDLE-MIN}$	Minimum time spent in electrical idle	20			ns
$T_{TX-IDLE-SET-TO-IDLE}$	Maximum time to transition to a valid electrical idle after sending an electrical idle ordered set.			8	ns
$T_{TX-IDLE-TO-DIFF-DATA}$	Maximum time to transition to valid differential signaling after leaving electrical idle.			8	ns
$T_{CROSSLINK}$	Crosslink random timeout.			1.0	ms
$C_{TX}$	AC coupling capacitor	75		200	nF

## 11.2.2 Differential Rx Input Electricals

This section describes the Rx input electricals.

### 11.2.2.1 PCI Express Rx Input Specifications Data - 2.5 GT/s

PCI Express Rx Input Specifications Data for 2.5 GT/s is described in **Table 23**.



In accordance with PCI Express Base Specification, Revision 2.1 March 4, 2009.

**Table 23: PCI Express Rx Input Specifications Data - 2.5 GT/s**

Symbol	Parameter	Minimum	Typical	Maximum	Unit
UI	Unit Interval (UI) UI does not account for SSC induced variations.	399.88		400.12	ps
$V_{RX-DIFF-PP-CC}$	Differential Rx peak-to-peak voltage for common Refclk Rx architecture.	0.175		1.2	V
$V_{RX-DIFF-PP-DC}$	Differential Rx peak-to-peak voltage for data clocked Rx architecture.	0.175		1.2	V
$T_{RX-EYE}$	Rx eye time opening Minimum eye time at Rx pins to yield a $10^{-12}$ BER.	0.40			UI
$T_{RX-EYE-MEDIAN-to-MAX-JITTER}$	Maximum time delta between median and deviation from median.			0.3	UI
$V_{RX-CM-ACp}$	AC peak common mode input voltage.			150	mV
$RL_{RX-DIFF}$	Differential return loss	15			dB
$RL_{RX-CM}$	Common mode return loss	0		3.6	dB
$Z_{RX-DIFF-DC}$	DC differential input impedance	80	100	120	W
$Z_{RX-DC}$	DC input impedance	40	50	60	W
$Z_{RX-HIGH-IMP-DC}$	Powered down DC input impedance	200			kΩ
$V_{RX-IDLE-DET-DIFF-p-p}$	Electrical idle detect threshold	65		175	mV
$T_{RX-IDLE-DET-DIFF-ENTERTIME}$	Unexpected electrical idle enter detect threshold integration time			10	ms

Symbol	Parameter	Minimum	Typical	Maximum	Unit
L <sub>RX-SKEW</sub>	Total skew			20	ns

### 11.2.2.2 PCI Express Rx Input Specifications Data - 5 GT/s

PCI Express Rx Input Specifications Data for 5 GT/s is described in **Table 24**.



In accordance with PCI Express Base Specification, Revision 2.1 March 4, 2009.

**Table 24: PCI Express Rx Input Specifications Data - 5 GT/s**

Symbol	Parameter	Minimum	Typical	Maximum	Unit
UI	Unit Interval (UI) UI does not account for SSC induced variations.	199.94		200.06	ps
V <sub>RX-DIFF-PP-CC</sub>	Differential Rx peak-to-peak voltage for common Refclk Rx architecture	0.120		1.2	V
V <sub>RX-DIFF-PP-DC</sub>	Differential Rx peak-to-peak voltage for data clocked Rx architecture	0.100		1.2	V
T <sub>RX-TJ-CC</sub>	Maximum Rx inherent total timing error for common Refclk Rx architecture.			0.40	UI
T <sub>RX-TJ-DC</sub>	Maximum Rx inherent total timing error for data clocked Rx architecture			0.34	UI
T <sub>RX-DJ-DD-CC</sub>	Maximum Rx inherent deterministic timing error for common Refclk Rx architecture			0.30	UI
T <sub>RX-DJ-DD-DC</sub>	Maximum Rx inherent deterministic timing error for data clocked Rx architecture			0.24	UI
T <sub>RX-MIN-PLISE</sub>	Minimum width pulse at Rx Measured to account for worst T <sub>j</sub> at 10-12 BER.	0.6			UI
V <sub>RX-CM-ACp</sub>	AC peak common mode input voltage			150	mV
R <sub>LRX-DIFF</sub>	Differential return loss	15			dB
R <sub>LRX-CM</sub>	Common mode return loss	0		3.6	dB
Z <sub>RX-DIFF-DC</sub>	DC differential input impedance	80	100	120	W
Z <sub>RX-DC</sub>	DC input impedance	40	50	60	W
Z <sub>RX-HIGH-IMP-DC</sub>	Powered down DC input impedance	200			kΩ
V <sub>RX-IDLE-DET-DIFF-p-p</sub>	Electrical idle detect threshold	65		175	mV
T <sub>RX-IDLE-DET-DIFF-ENTERTIME</sub>	Unexpected electrical idle enter detect threshold integration time			10	ms
L <sub>RX-SKEW</sub>	Total Skew			20	ns

## 11.3 USB Specifications

The USB 3.0 device interface pins are powered from the AVDD33 voltage supply.



Only if NXP supports USB SW.

### 11.3.1 USB LS Driver and Receiver Parameters

USB LS Driver and Receiver Parameters are described in **Table 25**.



- These parameters are in accordance with Universal Serial Bus 2.0 Specification, Revision 2.0, April 2000.
- The load is 100Ω differential for these parameters, unless other specified.

**Table 25: USB LS Driver and Receiver Specifications Data**

Symbol	Parameter	Minimum	Typical	Maximum	Unit
BR	Baud rate		1.5		Gbps
BRPPM	Baud rate tolerance	-15000.0		15000.0	ppm
<b>Driver Specifications</b>					
V <sub>OH</sub>	Output signal ended high Defined with 1.425 kΩ pull-up resistor to 3.6V.	2.8		3.6	V
V <sub>OL</sub>	Output signal ended low Defined with 1.425 kΩ pull-down register to ground.	0.0		0.3	V
V <sub>CRS</sub>	Output signal crossover voltage USB LS/FS Data Rise and Fall Time Diagram.	1.3		2.0	V
T <sub>LR</sub>	Data fall time <ul style="list-style-type: none"> <li>• USB LS/FS Data Rise and Fall Time Diagram.</li> <li>• Defined from 10% to 90% for rise time and 90% to 10% for fall time.</li> </ul>	75.0		300.0	ns
T <sub>LF</sub>	Data rise time. <ul style="list-style-type: none"> <li>• USB LS/FS Data Rise and Fall Time Diagram.</li> <li>• Defined from 10% to 90% for rise time and 90% to 10% for fall time.</li> </ul>	75.0		300.0	ns
T <sub>LRFM</sub>	Rise and fall time matching,	80.0		125.0	%
T <sub>UDJ1</sub>	Source jitter total: to next transition <ul style="list-style-type: none"> <li>• Including frequency tolerance. Timing difference between the differential data signals.</li> <li>• Defined at crossover point of differential data signals.</li> </ul>	-95.0		95.0	ns
T <sub>UDJ2</sub>	Source jitter total: for paired transitions <ul style="list-style-type: none"> <li>• Including frequency tolerance. Timing difference between the differential data signals.</li> <li>• Defined at crossover point of differential data signals.</li> </ul>	-150.0		150.0	ns
<b>Receiver Specifications</b>					
V <sub>IH</sub>	Input signal ended high	2.0			V
V <sub>IL</sub>	Input signal ended low			0.8	V
V <sub>DI</sub>	Differential input sensitivity	0.2			V

## 11.3.2 USB FS Driver and Receiver Parameters

USB FS Driver and Receiver Specifications Data are illustrated in **Table 26**.



- This data is in accordance with Universal Serial Bus 2.0 Specification, Revision 2.0, April 2000.
- The load is 100  $\Omega$  differential for these parameters, unless other specified.

**Table 26: USB FS Driver and Receiver Specifications Data**

Symbol	Parameter	Minimum	Typical	Maximum	Unit
BR	Baud rate		12.0		Mbps
BRPPM	Baud rate tolerance	-2500.0		2500.0	ppm
<b>Driver Specifications</b>					
V <sub>OH</sub>	Output signal ended high Defined with 1.425 k $\Omega$ pull-up resistor to 3.6V.	2.8		3.6	V
V <sub>OL</sub>	Output signal ended low Defined with 1.425 k $\Omega$ pull-down register to ground.	0.0		0.3	V
V <sub>CRS</sub>	Output signal crossover voltage USB LS/FS Data Rise and Fall Time Diagram.	1.3		2.0	V
T <sub>FR</sub>	Output rise time: <ul style="list-style-type: none"> <li>• USB LS/FS Data Rise and Fall Time Diagram.</li> <li>• Defined from 10% to 90% for rise time and 90% to 10% for fall time.</li> </ul>	-4.0		20.0	ns
T <sub>FL</sub>	Output fall time: <ul style="list-style-type: none"> <li>• USB LS/FS Data Rise and Fall Time Diagram.</li> <li>• Defined from 10% to 90% for rise time and 90% to 10% for fall time.</li> </ul>	-4.0		20.0	ns
T <sub>DJ1</sub>	Source jitter total to next transition: <ul style="list-style-type: none"> <li>• Including frequency tolerance. Timing difference between the differential data signals.</li> <li>• Defined at crossover point of differential data signals.</li> </ul>	-3.5		3.5	ns
T <sub>DJ2</sub>	Source jitter total for paired transitions: <ul style="list-style-type: none"> <li>• Including frequency tolerance. Timing difference between the differential data signals.</li> <li>• Defined at crossover point of differential data signals.</li> </ul>	-4.0		4.0	ns
T <sub>FDEOP</sub>	Source jitter for differential transition to SE0 transition <ul style="list-style-type: none"> <li>• Defined at crossover point of differential data signals.</li> </ul>	-2.0		5.0	ns
<b>Receiver Specifications</b>					
V <sub>IH</sub>	Input signal ended high	2.0			V
V <sub>IL</sub>	Input signal ended low			0.8	V
V <sub>DI</sub>	Differential input sensitivity	0.2			V
T <sub>JR1</sub>	Receiver jitter to next transition: <ul style="list-style-type: none"> <li>• Defined at crossover point of differential data signals.</li> </ul>	-18.5		18.5	ns

## 11.4 High Speed UART Specifications

Default baud rate is 115200 bps. Baud rate is configurable by the host stack. High speed UART specifications and parameters are shown in **Table 27** and **Figure 13**.

**Figure 13: High Speed UART Specifications**

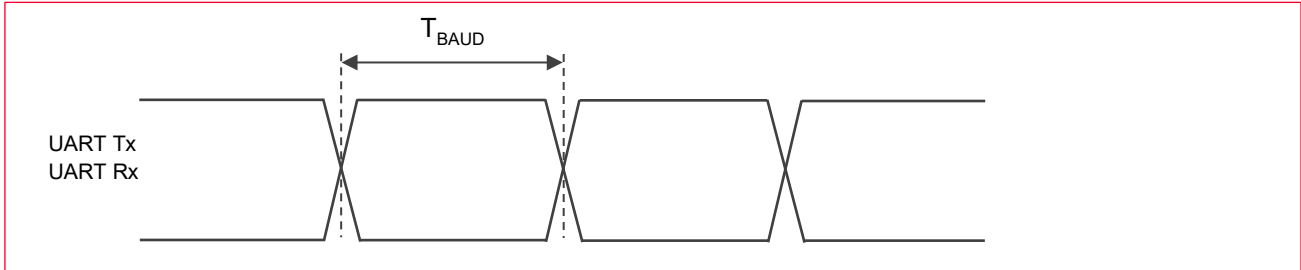

**Table 27: High Speed UART Specifications Parameters**

Symbol	Parameter	Condition	Minimum	Typical	Maximum	Unit
$T_{BAUD}$	Baud rate	40 MHz	250			ns



The acceptable deviation from the UART Rx target baud rate is  $\pm 3\%$ .

## 12 DC/RF Characteristics

ALL DC/RF characteristics are defined by following files as shown in **Table 28**. **Figure 14** shows the burst current definition for Type 1YM module.

**Table 28: DC/RF Characteristics and Files**

Characteristics	Filenames
WLAN Tx Power	txpower_US.bin, txpower_CA.bin, txpower_EU.bin, txpower_JP.bin
WLAN Regulatory Limit	db.txt
Energy Detect	ed_mac.bin
Bluetooth Power	bt_power_config_1.sh (Class 1), bt_power_config_2.sh (Class 2)

**Figure 14: Burst current definition**

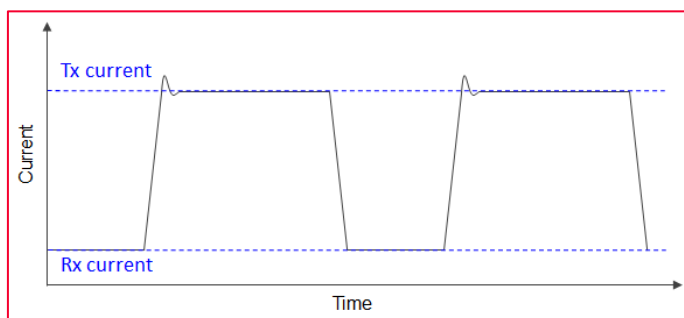

## 12.1 DC/RF Characteristics for IEEE 802.11b - 2.4 GHz

Items	Contents
Specification	IEEE 802.11b - 2.4 GHz
Mode	DSSS / CCK
Channel frequency (spacing)	2412 to 2472 MHz (5 MHz)
Data rate	1, 2, 5.5, 11 Mbps

### 12.1.1 High-Rate Condition for IEEE 802.11b - 2.4 GHz

**Conditions:** 25 °C, VBAT = 3.3V, VIO = 3.3V, Output power setting = 17 dBm at module pad, 11 Mbps mode (1-Antenna)

**Table 29: High-Rate Condition for IEEE 802.11b - 2.4 GHz**

Items	Contents			
Current Consumption	Minimum	Typical	Maximum	Unit
• Tx mode (99% Tx mode)		420	540	mA
• Rx mode		110	160	mA
Tx Characteristics	Minimum	Typical	Maximum	Unit
Output Power	15	17	19	dBm
Spectrum Mask Margin				
• 1 <sup>st</sup> side lobes			-30	dBr
• 2 <sup>nd</sup> side lobes			-50	dBr
Power-on/off ramp			2.0	μs
RF Carrier Suppression	15			dB
Modulation Accuracy			35	%
Frequency Tolerance	-20		20	ppm
Spurious Emissions				
• 30 - 47 MHz (BW = 100 kHz)			-36	dBm
• 47 - 74 MHz (BW = 100 kHz)			-54	dBm
• 74 - 87.5 MHz (BW = 100 kHz)			-36	dBm
• 87.5 - 118 MHz (BW = 100 kHz)			-54	dBm
• 118 - 174 MHz (BW = 100 kHz)			-36	dBm
• 174 - 230 MHz (BW = 100 kHz)			-54	dBm
• 230 - 470 MHz (BW = 100 kHz)			-36	dBm
• 470 - 862 MHz (BW = 100 kHz)			-54	dBm
• 862 - 1000 MHz (BW = 100 kHz)			-36	dBm
• 1000 - 12750 MHz (BW = 1 MHz)			-30	dBm
Rx Characteristics	Minimum	Typical	Maximum	Unit
Minimum Input Level (FER ≤ 8%)			-76	dBm
Maximum Input Level (FER ≤ 8%)	-10			dBm
Adjacent Channel Rejection (FER ≤ 8%)	35			dB

## 12.1.2 Low-Rate Condition for IEEE 802.11b - 2.4 GHz

**Conditions:** 25 °C, VBAT = 3.3V, VIO = 3.3V, Output power setting = 17 dBm at module pad, 1 Mbps mode (1-Antenna)

**Table 30: Low-Rate Condition for IEEE 802.11b - 2.4 GHz**

Items	Contents			
<b>Current Consumption</b>	<b>Minimum</b>	<b>Typical</b>	<b>Maximum</b>	<b>Unit</b>
• Tx mode (99% Tx mode)		420	540	mA
• Rx mode		110	160	mA
<b>Tx Characteristics</b>	<b>Minimum</b>	<b>Typical</b>	<b>Maximum</b>	<b>Unit</b>
Output Power	15	17	19	dBm
Spectrum Mask Margin				
• 1 <sup>st</sup> side lobes			-30	dBr
• 2 <sup>nd</sup> side lobes			-50	dBr
Power-on/off ramp			2.0	μs
RF Carrier Suppression	15			dB
Modulation Accuracy			35	%
Frequency Tolerance	-20		20	ppm
Spurious Emissions				
• 30 - 47 MHz (BW = 100 kHz)			-36	dBm
• 47 - 74 MHz (BW = 100 kHz)			-54	dBm
• 74 - 87.5 MHz (BW = 100 kHz)			-36	dBm
• 87.5 - 118 MHz (BW = 100 kHz)			-54	dBm
• 118 - 174 MHz (BW = 100 kHz)			-36	dBm
• 174 - 230 MHz (BW = 100 kHz)			-54	dBm
• 230 - 470 MHz (BW = 100 kHz)			-36	dBm
• 470 - 862 MHz (BW = 100 kHz)			-54	dBm
• 862 - 1000 MHz (BW = 100 kHz)			-36	dBm
• 1000 - 12750 MHz (BW = 1 MHz)			-30	dBm
<b>Rx Characteristics</b>	<b>Minimum</b>	<b>Typical</b>	<b>Maximum</b>	<b>Unit</b>
Minimum Input Level (FER ≤ 8%)			-80	dBm
Maximum Input Level (FER ≤ 8%)	-4			dBm
Adjacent Channel Rejection (FER ≤ 8%)	35			dB

## 12.2 DC/RF Characteristics for IEEE 802.11g - 2.4 GHz

Items	Contents
Specification	IEEE 802.11g - 2.4 GHz
Mode	OFDM
Channel frequency (spacing)	2412 to 2472 MHz (5 MHz)
Data rate	6, 9, 12, 18, 24, 36, 48, 54 Mbps

### 12.2.1 High-Rate Condition for IEEE 802.11g - 2.4 GHz

**Conditions:** 25 °C, VBAT = 3.3V, VIO = 3.3V, Output power setting = 13 dBm at module pad, 54 Mbps mode (1-Antenna)

**Table 31: High-Rate Condition for IEEE 802.11g - 2.4 GHz**

Items	Contents			
<b>Current Consumption</b>	<b>Minimum</b>	<b>Typical</b>	<b>Maximum</b>	<b>Unit</b>
• Tx mode (99% Tx mode)		310	380	mA
• Rx mode		110	160	mA
<b>Tx Characteristics</b>	<b>Minimum</b>	<b>Typical</b>	<b>Maximum</b>	<b>Unit</b>
Output Power	11	13	15	dBm
Spectrum Mask Margin				
• at fc +/- 11 MHz			-20	dBr
• at fc +/- 20 MHz			-28	dBr
• at fc ≥ +/-30 MHz			-40	dBr
Constellation Error			-25	dB
Frequency Tolerance	-20		20	ppm
Spurious Emissions				
• 30 - 47 MHz (BW = 100 kHz)			-36	dBm
• 47 - 74 MHz (BW = 100 kHz)			-54	dBm
• 74 - 87.5 MHz (BW = 100 kHz)			-36	dBm
• 87.5 - 118 MHz (BW = 100 kHz)			-54	dBm
• 118 - 174 MHz (BW = 100 kHz)			-36	dBm
• 174 - 230 MHz (BW = 100 kHz)			-54	dBm
• 230 - 470 MHz (BW = 100 kHz)			-36	dBm
• 470 - 862 MHz (BW = 100 kHz)			-54	dBm
• 862 - 1000 MHz (BW = 100 kHz)			-36	dBm
• 1000 - 12750 MHz (BW = 1 MHz)			-30	dBm
<b>Rx Characteristics</b>	<b>Minimum</b>	<b>Typical</b>	<b>Maximum</b>	<b>Unit</b>
Minimum Input Level (PER ≤ 10%)			-65	dBm
Maximum Input Level (PER ≤ 10%)	-20			dBm
Adjacent Channel Rejection (PER ≤ 10%)	-1			dB



## 12.2.2 Low-Rate Condition for IEEE 802.11g - 2.4 GHz

**Conditions:** 25 °C, VBAT = 3.3V, VIO = 3.3V, Output power setting = 16 dBm at module pad, 6 Mbps mode (1-Antenna)

**Table 32: Low-Rate Condition for IEEE 802.11g - 2.4 GHz**

Items	Contents			
<b>Current Consumption</b>	<b>Minimum</b>	<b>Typical</b>	<b>Maximum</b>	<b>Unit</b>
• Tx mode (99% Tx mode)		380	470	mA
• Rx mode		110	160	mA
<b>Tx Characteristics</b>	<b>Minimum</b>	<b>Typical</b>	<b>Maximum</b>	<b>Unit</b>
Output Power	14	16	18	dBm
Spectrum Mask Margin				
• at fc +/- 11 MHz			-20	dBr
• at fc +/- 20 MHz			-28	dBr
• at fc ≥ +/-30 MHz			-40	dBr
Constellation Error			-5	dB
Frequency Tolerance	-20		20	ppm
Spurious Emissions				
• 30 - 47 MHz (BW = 100 kHz)			-36	dBm
• 47 - 74 MHz (BW = 100 kHz)			-54	dBm
• 74 - 87.5 MHz (BW = 100 kHz)			-36	dBm
• 87.5 - 118 MHz (BW = 100 kHz)			-54	dBm
• 118 - 174 MHz (BW = 100 kHz)			-36	dBm
• 174 - 230 MHz (BW = 100 kHz)			-54	dBm
• 230 - 470 MHz (BW = 100 kHz)			-36	dBm
• 470 - 862 MHz (BW = 100 kHz)			-54	dBm
• 862 - 1000 MHz (BW = 100 kHz)			-36	dBm
• 1000 - 12750 MHz (BW = 1 MHz)			-30	dBm
<b>Rx Characteristics</b>	<b>Minimum</b>	<b>Typical</b>	<b>Maximum</b>	<b>Unit</b>
Minimum Input Level (PER ≤ 10%)			-82	dBm
Maximum Input Level (PER ≤ 10%)	-20			dBm
Adjacent Channel Rejection (PER ≤ 10%)	-1			dB

## 12.3 DC/RF Characteristics for IEEE 802.11n - 2.4 GHz

Items	Contents
Specification	IEEE 802.11n - 2.4 GHz
Mode	OFDM
Channel frequency (spacing)	2412 to 2472 MHz (5 MHz)
Data rate	6.5, 13, 19.5, 26, 39, 52, 58.5, 65 Mbps

### 12.3.1 High-Rate Condition for IEEE 802.11n - 2.4 GHz

**Conditions:** 25 °C, VBAT = 3.3V, VIO = 3.3V, Output power setting = 12 dBm at module pad, MCS7 mode (1-Antenna)

**Table 33: High-Rate Condition for IEEE 802.11n - 2.4 GHz**

Items	Contents			
Current Consumption	Minimum	Typical	Maximum	Unit
• Tx mode (99% Tx mode)		300	360	mA
• Rx mode		110	160	mA
Tx Characteristics	Minimum	Typical	Maximum	Unit
Output Power	10	12	14	dBm
Spectrum Mask Margin				
• at fc +/- 11 MHz			-20	dBr
• at fc +/- 20 MHz			-28	dBr
• at fc ≥ +/-30 MHz			-45	dBr
Constellation Error (measured at enhanced mode)			-27	dB
Frequency Tolerance	-20		20	ppm
Spurious Emissions				
• 30 - 47 MHz (BW = 100 kHz)			-36	dBm
• 47 - 74 MHz (BW = 100 kHz)			-54	dBm
• 74 - 87.5 MHz (BW = 100 kHz)			-36	dBm
• 87.5 - 118 MHz (BW = 100 kHz)			-54	dBm
• 118 - 174 MHz (BW = 100 kHz)			-36	dBm
• 174 - 230 MHz (BW = 100 kHz)			-54	dBm
• 230 - 470 MHz (BW = 100 kHz)			-36	dBm
• 470 - 862 MHz (BW = 100 kHz)			-54	dBm
• 862 - 1000 MHz (BW = 100 kHz)			-36	dBm
• 1000 - 12750 MHz (BW = 1 MHz)			-30	dBm
Rx Characteristics	Minimum	Typical	Maximum	Unit
Minimum Input Level (PER < 10%)			-64	dBm
Maximum Input Level (PER ≤ 10%)	-20			dBm
Adjacent Channel Rejection (PER ≤ 10%)	-2			dB

## 12.3.2 Low-Rate Condition for IEEE 802.11n - 2.4 GHz

**Conditions:** 25 °C, VBAT = 3.3V, VIO = 3.3V, Output power setting = 15 dBm at module pad, MCS0 mode (1-Antenna)

**Table 34: Low-Rate Condition for IEEE 802.11n - 2.4 GHz**

Items	Contents			
<b>Current Consumption</b>	<b>Minimum</b>	<b>Typical</b>	<b>Maximum</b>	<b>Unit</b>
• Tx mode (99% Tx mode)		360	440	mA
• Rx mode		110	160	mA
<b>Tx Characteristics</b>	<b>Minimum</b>	<b>Typical</b>	<b>Maximum</b>	<b>Unit</b>
Output Power	13	15	17	dBm
Spectrum Mask Margin				
• at fc +/- 11 MHz			-20	dBr
• at fc +/- 20 MHz			-28	dBr
• at fc ≥ +/-30 MHz			-45	dBr
Constellation Error (measured at enhanced mode)			-5	dB
Frequency Tolerance	-20		20	ppm
Spurious Emissions				
• 30 - 47 MHz (BW = 100 kHz)			-36	dBm
• 47 - 74 MHz (BW = 100 kHz)			-54	dBm
• 74 - 87.5 MHz (BW = 100 kHz)			-36	dBm
• 87.5 - 118 MHz (BW = 100 kHz)			-54	dBm
• 118 - 174 MHz (BW = 100 kHz)			-36	dBm
• 174 - 230 MHz (BW = 100 kHz)			-54	dBm
• 230 - 470 MHz (BW = 100 kHz)			-36	dBm
• 470 - 862 MHz (BW = 100 kHz)			-54	dBm
• 862 - 1000 MHz (BW = 100 kHz)			-36	dBm
• 1000 - 12750 MHz (BW = 1 MHz)			-30	dBm
<b>Rx Characteristics</b>	<b>Minimum</b>	<b>Typical</b>	<b>Maximum</b>	<b>Unit</b>
Minimum Input Level (PER ≤ 10%)			-82	dBm
Maximum Input Level (PER ≤ 10%)	-20			dBm
Adjacent Channel Rejection (PER ≤ 10%)	-2			dB

## 12.4 DC/RF Characteristics for IEEE 802.11a - 5 GHz

Items	Contents
Specification	IEEE 802.11a - 5 GHz
Mode	OFDM
Channel frequency (spacing)	5180 - 5825 MHz
Data rate	6, 9, 12, 18, 24, 36, 48, 54 Mbps

### 12.4.1 High-Rate Condition for IEEE 802.11a - 5 GHz

**Conditions:** 25 °C, VBAT = 3.3V, VIO = 3.3V, Output power setting = 12 dBm at module pad, 54 Mbps mode (1-Antenna)

**Table 35: High-Rate Condition for IEEE 802.11a - 5 GHz**

Items	Contents			
Current Consumption	Minimum	Typical	Maximum	Unit
• Tx mode (99% Tx mode)		330	390	mA
• Rx mode		125	180	mA
Tx Characteristics	Minimum	Typical	Maximum	Unit
Output Power	10	12	14	dBm
Spectrum Mask Margin				
• at fc +/- 11 MHz			-20	dBr
• at fc +/- 20 MHz			-28	dBr
• at fc ≥ +/-30 MHz			-40	dBr
Constellation Error			-25	dB
Frequency Tolerance	-20		20	ppm
Spurious Emissions				
• 30 - 47 MHz (BW = 100 kHz)			-36	dBm
• 47 - 74 MHz (BW = 100 kHz)			-54	dBm
• 74 - 87.5 MHz (BW = 100 kHz)			-36	dBm
• 87.5 - 118 MHz (BW = 100 kHz)			-54	dBm
• 118 - 174 MHz (BW = 100 kHz)			-36	dBm
• 174 - 230 MHz (BW = 100 kHz)			-54	dBm
• 230 - 470 MHz (BW = 100 kHz)			-36	dBm
• 470 - 862 MHz (BW = 100 kHz)			-54	dBm
• 862 - 1000 MHz (BW = 100 kHz)			-36	dBm
• 1000 - 5150 MHz (BW = 1 MHz)			-30	dBm
• 5350 - 5470 MHz (BW = 1 MHz)			-30	dBm
• 5725 - 26000 MHz (BW = 1 MHz)			-30	dBm
Rx Characteristics	Minimum	Typical	Maximum	Unit
Minimum Input Level (PER ≤ 10%)			-65	dBm
Maximum Input Level (PER ≤ 10%)	-30			dBm
Adjacent Channel Rejection (PER < 10%)	-1			dB

## 12.4.2 Low-Rate for IEEE 802.11a - 5 GHz

**Conditions:** 25 °C, VBAT = 3.3V, VIO = 3.3V, Output power setting = 14 dBm at module pad, 6 Mbps mode (1-Antenna)

**Table 36: Low-Rate Condition for IEEE 802.11a - 5 GHz**

Items	Contents			
Current Consumption	Minimum	Typical	Maximum	Unit
• Tx mode (99% Tx mode)		360	440	mA
• Rx mode		125	180	mA
Tx Characteristics	Minimum	Typical	Maximum	Unit
Output Power	12	14	16	dBm
Spectrum Mask Margin				
• at fc +/- 11 MHz			-20	dBr
• at fc +/- 20 MHz			-28	dBr
• at fc ≥ +/-30 MHz			-40	dBr
Constellation Error			-5	dB
Frequency Tolerance	-20		20	ppm
Spurious Emissions				
• 30 - 47 MHz (BW = 100 kHz)			-36	dBm
• 47 - 74 MHz (BW = 100 kHz)			-54	dBm
• 74 - 87.5 MHz (BW = 100 kHz)			-36	dBm
• 87.5 - 118 MHz (BW = 100 kHz)			-54	dBm
• 118 - 174 MHz (BW = 100 kHz)			-36	dBm
• 174 - 230 MHz (BW = 100 kHz)			-54	dBm
• 230 - 470 MHz (BW = 100 kHz)			-36	dBm
• 470 - 862 MHz (BW = 100 kHz)			-54	dBm
• 862 - 1000 MHz (BW = 100 kHz)			-36	dBm
• 1000 - 5150 MHz (BW = 1 MHz)			-30	dBm
• 5350 - 5470 MHz (BW = 1 MHz)			-30	dBm
• 5725 - 26000 MHz (BW = 1 MHz)			-30	dBm
Rx Characteristics	Minimum	Typical	Maximum	Unit
Minimum Input Level (PER ≤ 10%)			-82	dBm
Maximum Input Level (PER ≤ 10%)	-30			dBm
Adjacent Channel Rejection (PER < 10%)	-1			dB

## 12.5 DC/RF Characteristics for IEEE 802.11n (HT20) - 5 GHz

Items	Contents
Specification	IEEE 802.11n - 5 GHz
Mode	OFDM
Channel frequency (spacing)	5180 to 5825 MHz
Data rate	6.5, 13, 19.5, 26, 39, 52, 58.5, 65 Mbps

### 12.5.1 High-Rate Condition for IEEE 802.11n (HT20) - 5 GHz

**Conditions:** 25 °C, VBAT = 3.3V, VIO = 3.3V, Output power setting = 11 dBm at module pad, MCS7 mode (1-Antenna)

**Table 37: High-Rate Condition for IEEE 802.11n (HT20) - 5 GHz**

Items	Contents			
<b>Current Consumption</b>	<b>Minimum</b>	<b>Typical</b>	<b>Maximum</b>	<b>Unit</b>
• Tx mode (99% Tx mode)		320	370	mA
• Rx mode		125	180	mA
<b>Tx Characteristics</b>	<b>Minimum</b>	<b>Typical</b>	<b>Maximum</b>	<b>Unit</b>
Output Power	9	11	13	dBm
Spectrum Mask Margin				
• at fc +/- 11 MHz			-20	dBr
• at fc +/- 20 MHz			-28	dBr
• at fc ≥ +/-30 MHz			-40	dBr
Constellation Error (measured at enhanced mode)			-27	dB
Frequency Tolerance	-20		20	ppm
Spurious Emissions				
• 30 - 47 MHz (BW = 100 kHz)			-36	dBm
• 47 - 74 MHz (BW = 100 kHz)			-54	dBm
• 74 - 87.5 MHz (BW = 100 kHz)			-36	dBm
• 87.5 - 118 MHz (BW = 100 kHz)			-54	dBm
• 118 - 174 MHz (BW = 100 kHz)			-36	dBm
• 174 - 230 MHz (BW = 100 kHz)			-54	dBm
• 230 - 470 MHz (BW = 100 kHz)			-36	dBm
• 470 - 862 MHz (BW = 100 kHz)			-54	dBm
• 862 - 1000 MHz (BW = 100 kHz)			-36	dBm
• 1000 - 5150 MHz (BW = 1 MHz)			-30	dBm
• 5350 - 5470 MHz (BW = 1 MHz)			-30	dBm
• 5725 - 26000 MHz (BW = 1 MHz)			-30	dBm
<b>Rx Characteristics</b>	<b>Minimum</b>	<b>Typical</b>	<b>Maximum</b>	<b>Unit</b>
Minimum Input Level (PER ≤ 10%)			-64	dBm
Maximum Input Level (PER ≤ 10%)	-30			dBm
Adjacent Channel Rejection (PER < 10%)	16			dB

## 12.5.2 Low-Rate Condition for IEEE 802.11n (HT20) - 5 GHz

**Conditions:** 25 °C, VBAT = 3.3V, VIO = 3.3V, Output power setting = 14 dBm at module pad, MCS0 mode (1-Antenna)

**Table 38: Low-Rate Condition for IEEE 802.11n (HT20) - 5 GHz**

Items	Contents			
	Minimum	Typical	Maximum	Unit
<b>Current Consumption</b>				
• Tx mode (99% Tx mode)		370	440	mA
• Rx mode		125	180	mA
<b>Tx Characteristics</b>	<b>Minimum</b>	<b>Typical</b>	<b>Maximum</b>	<b>Unit</b>
Output Power	12	14	16	dBm
Spectrum Mask Margin				
• at fc +/- 11 MHz			-20	dBr
• at fc +/- 20 MHz			-28	dBr
• at fc ≥ +/-30 MHz			-40	dBr
Constellation Error (measured at enhanced mode)			-5	dB
Frequency Tolerance	-20		20	ppm
Spurious Emissions				
• 30 - 47 MHz (BW = 100 kHz)			-36	dBm
• 47 - 74 MHz (BW = 100 kHz)			-54	dBm
• 74 - 87.5 MHz (BW = 100 kHz)			-36	dBm
• 87.5 - 118 MHz (BW = 100 kHz)			-54	dBm
• 118 - 174 MHz (BW = 100 kHz)			-36	dBm
• 174 - 230 MHz (BW = 100 kHz)			-54	dBm
• 230 - 470 MHz (BW = 100 kHz)			-36	dBm
• 470 - 862 MHz (BW = 100 kHz)			-54	dBm
• 862 - 1000 MHz (BW = 100 kHz)			-36	dBm
• 1000 - 5150 MHz (BW = 1 MHz)			-30	dBm
• 5350 - 5470 MHz (BW = 1 MHz)			-30	dBm
• 5725 - 26000 MHz (BW = 1 MHz)			-30	dBm
<b>Rx Characteristics</b>	<b>Minimum</b>	<b>Typical</b>	<b>Maximum</b>	<b>Unit</b>
Minimum Input Level (PER ≤ 10%)			-82	dBm
Maximum Input Level (PER ≤ 10%)	-30			dBm
Adjacent Channel Rejection (PER < 10%)	16			dB

## 12.6 DC/RF Characteristics for IEEE 802.11ac (VHT20) - 5 GHz

Items	Contents
Specification	IEEE 802.11ac - 5 GHz
Mode	OFDM
Channel frequency (spacing)	5180 to 5825 MHz
Data rate	6.5, 13, 19.5, 26, 39, 52, 58.5, 65, 78 Mbps

### 12.6.1 High-Rate Condition for IEEE 802.11ac (VHT20) - 5 GHz

**Conditions:** 25 °C, VBAT = 3.3V, VIO = 3.3V, Output power setting = 10 dBm at module pad, MCS8 mode (1-Antenna)

**Table 39: High-Rate Condition for IEEE 802.11ac (VHT20) - 5 GHz**

Items	Contents			
	Minimum	Typical	Maximum	Unit
<b>Current Consumption</b>				
• Tx mode (99% Tx mode)		300	355	mA
• Rx mode		125	180	mA
<b>Tx Characteristics</b>	<b>Minimum</b>	<b>Typical</b>	<b>Maximum</b>	<b>Unit</b>
Output Power	8	10	12	dBm
Spectrum Mask Margin				
• at fc +/- 11 MHz			-20	dBr
• at fc +/- 20 MHz			-28	dBr
• at fc ≥ +/-30 MHz			-40	dBr
Constellation Error (measured at enhanced mode)			-30	dB
Frequency Tolerance	-20		20	ppm
Spurious Emissions				
• 30 - 47 MHz (BW = 100 kHz)			-36	dBm
• 47 - 74 MHz (BW = 100 kHz)			-54	dBm
• 74 - 87.5 MHz (BW = 100 kHz)			-36	dBm
• 87.5 - 118 MHz (BW = 100 kHz)			-54	dBm
• 118 - 174 MHz (BW = 100 kHz)			-36	dBm
• 174-230 MHz (BW = 100 kHz)			-54	dBm
• 230 - 470 MHz (BW = 100 kHz)			-36	dBm
• 470 - 862 MHz (BW = 100 kHz)			-54	dBm
• 862 - 1000 MHz (BW = 100 kHz)			-36	dBm
• 1000 - 5150 MHz (BW = 1 MHz)			-30	dBm
• 5350 - 5470 MHz (BW = 1 MHz)			-30	dBm
• 5725 - 26000 MHz (BW = 1 MHz)			-30	dBm
<b>Rx Characteristics</b>	<b>Minimum</b>	<b>Typical</b>	<b>Maximum</b>	<b>Unit</b>
Minimum Input Level (PER ≤ 10%)			-59	dBm
Maximum Input Level (PER ≤ 10%)	-30			dBm
Adjacent Channel Rejection (PER < 10%)	-16			dB



## 12.6.2 Low-Rate Condition for IEEE 802.11ac (VHT20) - 5 GHz

**Conditions:** 25 °C, VBAT = 3.3V, VIO = 3.3V, Output power setting = 14 dBm at module pad, MCS0 mode (1-Antenna)

**Table 40: Low-Rate Condition for IEEE 802.11ac (VHT20) - 5 GHz**

Items	Contents			
	Minimum	Typical	Maximum	Unit
<b>Current Consumption</b>				
• Tx mode (99% Tx mode)		360	435	mA
• Rx mode		125	180	mA
<b>Tx Characteristics</b>	<b>Minimum</b>	<b>Typical</b>	<b>Maximum</b>	<b>Unit</b>
Output Power	12	14	16	dBm
Spectrum Mask Margin				
• at fc +/- 11 MHz			-20	dBr
• at fc +/- 20 MHz			-28	dBr
• at fc ≥ +/-30 MHz			-40	dBr
Constellation Error (measured at enhanced mode)			-5	dB
Frequency Tolerance	-20		20	ppm
Spurious Emissions				
• 30 - 47 MHz (BW = 100 kHz)			-36	dBm
• 47 - 74 MHz (BW = 100 kHz)			-54	dBm
• 74 - 87.5 MHz (BW = 100 kHz)			-36	dBm
• 87.5 - 118 MHz (BW = 100 kHz)			-54	dBm
• 118 - 174 MHz (BW = 100 kHz)			-36	dBm
• 174 - 230 MHz (BW = 100 kHz)			-54	dBm
• 230 - 470 MHz (BW = 100 kHz)			-36	dBm
• 470 - 862 MHz (BW = 100 kHz)			-54	dBm
• 862 - 1000 MHz (BW = 100 kHz)			-36	dBm
• 1000 - 5150 MHz (BW = 1 MHz)			-30	dBm
• 5350 - 5470 MHz (BW = 1 MHz)			-30	dBm
• 5725 - 26000 MHz (BW = 1 MHz)			-30	dBm
<b>Rx Characteristics</b>	<b>Minimum</b>	<b>Typical</b>	<b>Maximum</b>	<b>Unit</b>
Minimum Input Level (PER ≤ 10%)			-82	dBm
Maximum Input Level (PER ≤ 10%)	-30			dBm
Adjacent Channel Rejection (PER < 10%)	16			dB

## 12.7 DC/RF Characteristics for IEEE 802.11n (HT40) - 5 GHz

Items	Contents
Specification	IEEE 802.11n - 5 GHz
Mode	OFDM
Channel frequency (spacing)	5180 to 5825 MHz
Data rate	13.5,27,40.5,54,81,108,121.5,135 Mbps

### 12.7.1 High-Rate Condition for IEEE 802.11n (HT40) - 5 GHz

**Conditions:** 25 °C, VBAT = 3.3V, VIO = 3.3V, Output power setting = 11 dBm at module pad, MCS7 mode (1-Antenna)

**Table 41: High-Rate Condition for IEEE 802.11n (HT40) - 5 GHz**

Items	Contents			
	Minimum	Typical	Maximum	Unit
<b>Current Consumption</b>				
• Tx mode (99% Tx mode)		310	370	mA
• Rx mode		140	200	mA
<b>Tx Characteristics</b>	<b>Minimum</b>	<b>Typical</b>	<b>Maximum</b>	<b>Unit</b>
Output Power	9	11	13	dBm
Spectrum Mask Margin				
• at fc +/- 21 MHz			-20	dBr
• at fc +/- 40 MHz			-28	dBr
• at fc ≥ +/-60 MHz			-40	dBr
Constellation Error (measured at enhanced mode)			-27	dB
Frequency Tolerance	-20		20	ppm
Spurious Emissions				
• 30 - 47 MHz (BW = 100 kHz)			-36	dBm
• 47 - 74 MHz (BW = 100 kHz)			-54	dBm
• 74 - 87.5 MHz (BW = 100 kHz)			-36	dBm
• 87.5 - 118 MHz (BW = 100 kHz)			-54	dBm
• 118 - 174 MHz (BW = 100 kHz)			-36	dBm
• 174 - 230 MHz (BW = 100 kHz)			-54	dBm
• 230 - 470 MHz (BW = 100 kHz)			-36	dBm
• 470 - 862 MHz (BW = 100 kHz)			-54	dBm
• 862 - 1000 MHz (BW = 100 kHz)			-36	dBm
• 1000 - 5150 MHz (BW = 1 MHz)			-30	dBm
• 5350 - 5470 MHz (BW = 1 MHz)			-30	dBm
• 5725 - 26000 MHz (BW = 1 MHz)			-30	dBm
<b>Rx Characteristics</b>	<b>Minimum</b>	<b>Typical</b>	<b>Maximum</b>	<b>Unit</b>
Minimum Input Level (PER ≤ 10%)			-61	dBm
Maximum Input Level (PER ≤ 10%)	-30			dBm
Adjacent Channel Rejection (PER < 10%)	-2			dB

## 12.7.2 Low-Rate Condition for IEEE 802.11n (HT40) - 5 GHz

**Conditions:** 25 °C, VBAT = 3.3V, VIO = 3.3V, Output power setting = 13 dBm at module pad, MCS0 mode (1-Antenna)

**Table 42: Low-Rate Condition for IEEE 802.11n (HT40) - 5 GHz**

Items	Contents			
Current Consumption	Minimum	Typical	Maximum	Unit
• Tx mode (99% Tx mode)		350	415	mA
• Rx mode		140	200	mA
Tx Characteristics	Minimum	Typical	Maximum	Unit
Output Power	11	13	15	dBm
Spectrum Mask Margin				
• at fc +/- 21 MHz			-20	dBr
• at fc +/- 40 MHz			-28	dBr
• at fc ≥ +/-60 MHz			-40	dBr
Constellation Error (measured at enhanced mode)			-5	dB
Frequency Tolerance	-20		20	ppm
Spurious Emissions				
• 30 - 47 MHz (BW = 100 kHz)			-36	dBm
• 47 - 74 MHz (BW = 100 kHz)			-54	dBm
• 74 - 87.5 MHz (BW = 100 kHz)			-36	dBm
• 87.5 - 118 MHz (BW = 100 kHz)			-54	dBm
• 118 - 174 MHz (BW = 100 kHz)			-36	dBm
• 174 - 230 MHz (BW = 100 kHz)			-54	dBm
• 230 - 470 MHz (BW = 100 kHz)			-36	dBm
• 470 - 862 MHz (BW = 100 kHz)			-54	dBm
• 862 - 1000 MHz (BW = 100 kHz)			-36	dBm
• 1000 - 5150 MHz (BW = 1 MHz)			-30	dBm
• 5350 - 5470 MHz (BW = 1 MHz)			-30	dBm
• 5725 - 26000 MHz (BW = 1 MHz)			-30	dBm
Rx Characteristics	Minimum	Typical	Maximum	Unit
Minimum Input Level (PER ≤ 10%)			-79	dBm
Maximum Input Level (PER ≤ 10%)	-30			dBm
Adjacent Channel Rejection (PER < 10%)	-2			dB

## 12.8 DC/RF Characteristics for IEEE 802.11ac (VHT40) - 5 GHz

Items	Contents
Specification	IEEE 802.11ac - 5 GHz
Mode	OFDM
Channel frequency (spacing)	5190 to 5795 MHz
Data rate	13.5, 27, 40.5, 54, 81, 108, 121.5, 135, 162, 180 Mbps

### 12.8.1 High-Rate Condition for IEEE 802.11ac (VHT40) - 5 GHz

**Conditions:** 25 °C, VBAT = 3.3V, VIO = 3.3V, Output power setting = 10 dBm at module pad, MCS9 mode (1-Antenna)

**Table 43: High-Rate Condition for IEEE 802.11ac (VHT40) - 5 GHz**

Items	Contents			
	Minimum	Typical	Maximum	Unit
<b>Current Consumption</b>				
• Tx mode (99% Tx mode)		300	350	mA
• Rx mode		140	200	mA
<b>Tx Characteristics</b>	<b>Minimum</b>	<b>Typical</b>	<b>Maximum</b>	<b>Unit</b>
Output Power	8	10	12	dBm
Spectrum Mask Margin				
• at fc +/- 21 MHz			-20	dBr
• at fc +/- 40 MHz			-28	dBr
• at fc ≥ +/-60 MHz			-40	dBr
Constellation Error (measured at enhanced mode)			-32	dB
Frequency Tolerance	-20		20	ppm
Spurious Emissions				
• 30 - 47 MHz (BW = 100 kHz)			-36	dBm
• 47 - 74 MHz (BW = 100 kHz)			-54	dBm
• 74 - 87.5 MHz (BW = 100 kHz)			-36	dBm
• 87.5 - 118 MHz (BW = 100 kHz)			-54	dBm
• 118 - 174 MHz (BW = 100 kHz)			-36	dBm
• 174 - 230 MHz (BW = 100 kHz)			-54	dBm
• 230 - 470 MHz (BW = 100 kHz)			-36	dBm
• 470 - 862 MHz (BW = 100 kHz)			-54	dBm
• 862 - 1000 MHz (BW = 100 kHz)			-36	dBm
• 1000 - 5150 MHz (BW = 1 MHz)			-30	dBm
• 5350 - 5470 MHz (BW = 1 MHz)			-30	dBm
• 5725 - 26000 MHz (BW = 1 MHz)			-30	dBm
<b>Rx Characteristics</b>	<b>Minimum</b>	<b>Typical</b>	<b>Maximum</b>	<b>Unit</b>
Minimum Input Level (PER ≤ 10%)			-54	dBm
Maximum Input Level (PER ≤ 10%)	-30			dBm

## 12.8.2 Low-Rate Condition for IEEE 802.11ac (VHT40) - 5 GHz

**Conditions:** 25 °C, VBAT = 3.3V, VIO = 3.3V, Output power setting = 13 dBm at module pad, MCS0 mode (1-Antenna)

**Table 44: Low-Rate Condition for IEEE 802.11ac (VHT40) - 5 GHz**

Items	Contents			
	Minimum	Typical	Maximum	Unit
<b>Current Consumption</b>				
• Tx mode (99% Tx mode)		350	410	mA
• Rx mode		140	200	mA
<b>Tx Characteristics</b>	<b>Minimum</b>	<b>Typical</b>	<b>Maximum</b>	<b>Unit</b>
Output Power	11	13	15	dBm
Spectrum Mask Margin				
• at fc +/- 21 MHz			-20	dBr
• at fc +/- 40 MHz			-28	dBr
• at fc ≥ +/-60 MHz			-40	dBr
Constellation Error (measured at enhanced mode)			-5	dB
Frequency Tolerance	-20		20	ppm
Spurious Emissions				
• 30 - 47 MHz (BW = 100 kHz)			-36	dBm
• 47 - 74 MHz (BW = 100 kHz)			-54	dBm
• 74 - 87.5 MHz (BW = 100 kHz)			-36	dBm
• 87.5 - 118 MHz (BW = 100 kHz)			-54	dBm
• 118 - 174 MHz (BW = 100 kHz)			-36	dBm
• 174 - 230 MHz (BW = 100 kHz)			-54	dBm
• 230 - 470 MHz (BW = 100 kHz)			-36	dBm
• 470 - 862 MHz (BW = 100 kHz)			-54	dBm
• 862 - 1000 MHz (BW = 100 kHz)			-36	dBm
• 1000 - 5150 MHz (BW = 1 MHz)			-30	dBm
• 5350 - 5470 MHz (BW = 1 MHz)			-30	dBm
• 5725 - 26000 MHz (BW = 1 MHz)			-30	dBm
<b>Rx Characteristics</b>	<b>Minimum</b>	<b>Typical</b>	<b>Maximum</b>	<b>Unit</b>
Minimum Input Level (PER ≤ 10%)			-79	dBm
Maximum Input Level (PER ≤ 10%)	-30			dBm

## 12.9 DC/RF Characteristics for IEEE 802.11ac (VHT80) - 5 GHz

Items	Contents
Specification	IEEE 802.11ac - 5 GHz
Mode	OFDM
Channel frequency (spacing)	5210 to 5775 MHz
Data rate	29.3, 58.5, 87.8, 117, 175.5, 234, 263.3, 292.5, 351, 390 Mbps

### 12.9.1 High-Rate Condition for IEEE 802.11ac (VHT80) - 5 GHz

**Conditions:** 25 °C, VBAT = 3.3V, VIO = 3.3V, Output power setting = 10 dBm at module pad, MCS9 mode (1-Antenna)

**Table 45: High-Rate Condition for IEEE 802.11ac (VHT80) - 5 GHz**

Items	Contents			
	Minimum	Typical	Maximum	Unit
<b>Current Consumption</b>				
• Tx mode (99% Tx mode)		310	365	mA
• Rx mode		160	220	mA
<b>Tx Characteristics</b>	<b>Minimum</b>	<b>Typical</b>	<b>Maximum</b>	<b>Unit</b>
Output Power	8	10	12	dBm
Spectrum Mask Margin				
• at fc +/- 41 MHz			-20	dBr
• at fc +/- 80 MHz			-28	dBr
• at fc > +/-120 MHz			-40	dBr
Constellation Error (measured at enhanced mode)			-32	dB
Spurious Emissions				
• 30 - 47 MHz (BW = 100 kHz)			-36	dBm
• 47 - 74 MHz (BW = 100 kHz)			-54	dBm
• 74 - 87.5 MHz (BW = 100 kHz)			-36	dBm
• 87.5 - 118 MHz (BW = 100 kHz)			-54	dBm
• 118 - 174 MHz (BW = 100 kHz)			-36	dBm
• 174 - 230 MHz (BW = 100 kHz)			-54	dBm
• 230 - 470 MHz (BW = 100 kHz)			-36	dBm
• 470 - 862 MHz (BW = 100 kHz)			-54	dBm
• 862 - 1000 MHz (BW = 100 kHz)			-36	dBm
• 1000 - 5150 MHz (BW = 1 MHz)			-30	dBm
• 5350 - 5470 MHz (BW = 1 MHz)			-30	dBm
• 5725 - 26000 MHz (BW = 1 MHz)			-30	dBm
<b>Rx Characteristics</b>	<b>Minimum</b>	<b>Typical</b>	<b>Maximum</b>	<b>Unit</b>
Minimum Input Level (PER ≤ 10%)			-51	dBm
Maximum Input Level (PER ≤ 10%)	-30			dBm
Adjacent Channel Rejection (PER < 10%)	-9			dB

## 12.9.2 Low-Rate Condition for IEEE 802.11ac (VHT80) - 5 GHz

**Conditions:** 25 °C, VBAT = 3.3V, VIO = 3.3V, Output power setting = 12 dBm at module pad, MCS0 mode (1-Antenna)

**Table 46: Low-Rate Condition for IEEE 802.11ac (VHT80) - 5 GHz**

Items	Contents			
Current Consumption	Minimum	Typical	Maximum	Unit
• Tx mode (99% Tx mode)		340	395	mA
• Rx mode		160	220	mA
Tx Characteristics	Minimum	Typical	Maximum	Unit
Output Power	10	12	14	dBm
Spectrum Mask Margin				
• at fc +/- 41 MHz			-20	dBr
• at fc +/- 80 MHz			-28	dBr
• at fc ≥ +/-120 MHz			-40	dBr
Constellation Error (measured at enhanced mode)			-5	dB
Spurious Emissions				
• 30 - 47 MHz (BW = 100 kHz)			-36	dBm
• 47 - 74 MHz (BW = 100 kHz)			-54	dBm
• 74 - 87.5 MHz (BW = 100 kHz)			-36	dBm
• 87.5 - 118 MHz (BW = 100 kHz)			-54	dBm
• 118 - 174 MHz (BW = 100 kHz)			-36	dBm
• 174 - 230 MHz (BW = 100 kHz)			-54	dBm
• 230 - 470 MHz (BW = 100 kHz)			-36	dBm
• 470 - 862 MHz (BW = 100 kHz)			-54	dBm
• 862 - 1000 MHz (BW = 100 kHz)			-36	dBm
• 1000 - 5150 MHz (BW = 1 MHz)			-30	dBm
• 5350 - 5470 MHz (BW = 1 MHz)			-30	dBm
• 5725 - 26000 MHz (BW = 1 MHz)			-30	dBm
Rx Characteristics	Minimum	Typical	Maximum	Unit
Minimum Input Level (PER ≤ 10%)			-76	dBm
Maximum Input Level (PER ≤ 10%)	-30			dBm
Adjacent Channel Rejection (PER < 10%)	-9			dB

## 12.10 DC/RF Characteristics for Bluetooth

Items	Contents
Bluetooth specification (power class)	Version 5.2 (Class 1)
Channel frequency (spacing)	2402 to 2480 MHz (1 MHz)
Number of RF Channel	79

### 12.10.1 Basic Data Rate Condition

**Conditions:** 25 °C, VBAT = 3.3V, VIO = 3.3V (Test method: Bluetooth Core Spec Vol.3 Part D)

**Table 47: Basic Data Rate Condition**

Items	Contents			
	Minimum	Typical	Maximum	Unit
<b>Current Consumption</b>				
• Tx mode DH5		70	150	mA
• Rx mode DH5		70	125	mA
<b>Tx Characteristics</b>	<b>Minimum</b>	<b>Typical</b>	<b>Maximum</b>	<b>Unit</b>
Output Power@DH5	0	3	6	dBm
Frequency range	2400		2483.5	MHz
20 dB bandwidth			1	MHz
Adjacent Channel Power <sup>9</sup>				
• [M-N] = 2			-20	dBm
• [M-N] ≥ 3			-40	dBm
Modulation characteristics				
• Modulation $\Delta f_{1\text{avg}}$	140	151	175	kHz
• Modulation $\Delta f_{2\text{max}}$	115			kHz
• Modulation $\Delta f_{2\text{avg}} / \Delta f_{1\text{avg}}$	0.8	1		
Carrier Frequency Drift				
• 1 slot	-25		25	kHz
• 3 slot / 5 slot	-40		40	kHz
• Maximum drift rate			20	kHz/50 $\mu$ s
<b>Rx Characteristics</b>	<b>Minimum</b>	<b>Typical</b>	<b>Maximum</b>	<b>Unit</b>
BDR Sensitivity (BER ≤ 0.1%)		-96	-70	dBm
Maximum Input Level (BER ≤ 0.1%)	-20			dBm

<sup>9</sup> Up to three spurious responses within Bluetooth limits are allowed.



## 12.10.2 Enhanced Data Rate Condition

**Conditions:** 25 °C, VBAT = 3.3V, VIO = 3.3V (Test method: Bluetooth Core Spec Vol.3 Part D)

**Table 48: Enhanced Data Rate Condition**

Items	Contents			
Current Consumption	Minimum	Typical	Maximum	Unit
• Tx mode 2DH5		70	150	mA
• Rx mode 2DH5		70	125	mA
• Tx mode 3DH5		70	150	mA
• Rx mode 3DH5		70	125	mA
Tx Characteristics	Minimum	Typical	Maximum	Unit
Output Power@2DH5/3DH5	-3	0	3	dBm
Frequency range	2400		2483.5	MHz
20 dB bandwidth			1	MHz
Adjacent Channel Power <sup>10</sup>				
• [M-N] = 2			-20	dBm
• [M-N] ≥ 3			-40	dBm
EDR Relative Power	-4		1	dB
EDR Carrier Frequency Stability and Modulation Accuracy				
• $\omega_i$	-75		75	kHz
• $\omega_i + \omega_o$	-75		75	kHz
• $\omega_o$	-10		10	kHz
• RMS DEVM (DQPSK)			20	%
• Peak DEVM (DQPSK)			35	%
• 99% DEVM (DQPSK)			30	%
• RMS DEVM (8DPSK)			13	%
• Peak DEVM (8DPSK)			25	%
• 99% DEVM (8DPSK)			20	%
Spurious Emissions				
• 30 - 47 MHz (BW = 100 kHz)			-36	dBm
• 47 - 74 MHz (BW = 100 kHz)			-54	dBm
• 74 - 87.5 MHz (BW = 100 kHz)			-36	dBm
• 87.5 - 118 MHz (BW = 100 kHz)			-54	dBm
• 118 - 174 MHz (BW = 100 kHz)			-36	dBm
• 174 - 230 MHz (BW = 100 kHz)			-54	dBm
• 230 - 470 MHz (BW = 100 kHz)			-36	dBm
• 470 - 862 MHz (BW = 100 kHz)			-54	dBm
• 862 - 1000 MHz (BW = 100 kHz)			-36	dBm
• 1000 - 12750 MHz (BW = 1 MHz)			-30	dBm
Rx Characteristics	Minimum	Typical	Maximum	Unit
EDR Sensitivity (BER ≤ 0.007%) @8DPSK		-88	-70	dBm
Maximum Input Level (BER ≤ 0.1%)	-20			dBm

<sup>10</sup> Up to three spurious responses within Bluetooth limits are allowed.

## 12.11 DC/RF Characteristics for Bluetooth Low Energy

Items	Contents
Bluetooth specification (power class)	Version 5.2 (Class 1.5)
Channel frequency (spacing)	2402 to 2480 MHz (2 MHz)
Number of RF Channel	40

### 12.11.1 1 Mbps PHY Condition

**Conditions:** 25 °C, VBAT = 3.3V, VIO = 3.3V (Test method: Bluetooth Core Spec Vol. 6 Part F)

**Table 49: 1 Mbps PHY Condition**

Items	Contents			
<b>Current Consumption</b>	<b>Minimum</b>	<b>Typical</b>	<b>Maximum</b>	<b>Unit</b>
• Tx mode		70	150	mA
• Rx mode		70	125	mA
<b>Tx Characteristics</b>	<b>Minimum</b>	<b>Typical</b>	<b>Maximum</b>	<b>Unit</b>
Center Frequency	2402		2480	MHz
Channel Spacing		2		MHz
Number of RF channel		40		
Output power	0	3	6	dBm
In-band emission				
• $f_{TX} \pm 2$ MHz			-20	dBm
• $f_{TX} \pm [3+n]$ MHz; n = 0,1,2...			-30	dBm
Modulation Characteristics				
• $\Delta f_{1_{avg}}$	225		275	kHz
• $\Delta f_{2_{max}}$ (at 99.9%)	185			kHz
• $\Delta f_{2_{avg}} / \Delta f_{1_{avg}}$	0.8			
Stable Modulation Characteristics				
• $\Delta f_{1_{avg}}$	247.5		252.5	kHz
• $\Delta f_{2_{max}}$ (at 99.9%)	185			kHz
• $\Delta f_{2_{avg}} / \Delta f_{1_{avg}}$	0.8			
Carrier frequency offset and drift				
• Frequency offset ( $f_n$ ); n = 0,1,2,3...k	-150		150	kHz
• Frequency drift ( $ f_0 - f_n $ ); n = 2,3,4...k			50	kHz
• Drift rate				
• $ f_1 - f_0 $			23	kHz
• $ f_n - f_{n-5} $ ; n = 6,7, 8,...k			20	kHz
Spurious Emissions				
• 30 - 47 MHz (BW = 100 kHz)			-36	dBm
• 47 - 74 MHz (BW = 100 kHz)			-54	dBm
• 74 - 87.5 MHz (BW = 100 kHz)			-36	dBm

Items	Contents			
• 87.5 - 118 MHz (BW = 100 kHz)			-54	dBm
• 118 - 174 MHz (BW = 100 kHz)			-36	dBm
• 174 - 230 MHz (BW = 100 kHz)			-54	dBm
• 230 - 470 MHz (BW = 100 kHz)			-36	dBm
• 470 - 862 MHz (BW = 100 kHz)			-54	dBm
• 862 - 1000 MHz (BW = 100 kHz)			-36	dBm
• 1000 - 12750 MHz (BW = 1 MHz)			-30	dBm
Rx Characteristics	Minimum	Typical	Maximum	Unit
Receiver sensitivity (PER < 30.8%)		-97	-70	dBm
Maximum input signal level (PER < 30.8%)	-10			dBm
PER Report Integrity (-30 dBm input)	50		65.4	%

## 12.11.2 2 Mbps PHY Condition

**Conditions:** 25 °C, VBAT = 3.3V, VIO = 3.3V (Test method: Bluetooth Core Spec Vol. 6 Part F)

**Table 50: 2 Mbps PHY Condition**

Items	Contents			
Current Consumption	Minimum	Typical	Maximum	Unit
• Tx mode		70	150	mA
• Rx mode		70	125	mA
Tx Characteristics	Minimum	Typical	Maximum	Unit
Center Frequency	2402		2480	MHz
Channel Spacing		2		MHz
Number of RF channel		40		
Output power	0	3	6	dBm
In-band emission				
• $f_{TX} \pm 4$ MHz			-20	dBm
• $f_{TX} \pm 5$ MHz			-20	dBm
• $f_{TX} \pm [6+n]$ MHz; $n = 0, 1, 2, \dots$			-30	dBm
Modulation Characteristics				
• $\Delta f_{1\text{avg}}$	450		550	kHz
• $\Delta f_{2\text{max}}$ (at 99.9%)	370			kHz
• $\Delta f_{2\text{avg}} / \Delta f_{1\text{avg}}$	0.8			-
Stable Modulation Characteristics				
• $\Delta f_{1\text{avg}}$	495		505	kHz
• $\Delta f_{2\text{max}}$ (at 99.9%)	370			kHz
• $\Delta f_{2\text{avg}} / \Delta f_{1\text{avg}}$	0.8			
Carrier frequency offset and drift				

Items	Contents			
• Frequency offset ( $f_n$ ); $n = 0, 1, 2, 3 \dots k$	-150		150	kHz
• Frequency drift ( $ f_0 - f_n $ ); $n = 2, 3, 4 \dots k$			50	kHz
• Drift rate				
• $ f_1 - f_0 $			23	kHz
• $ f_n - f_{n-5} $ ; $n = 6, 7, 8, \dots k$			20	kHz
Spurious Emissions				
• 30 - 47 MHz (BW = 100 kHz)			-36	dBm
• 47 - 74 MHz (BW = 100 kHz)			-54	dBm
• 74 - 87.5 MHz (BW = 100 kHz)			-36	dBm
• 87.5 - 118 MHz (BW = 100 kHz)			-54	dBm
• 118 - 174 MHz (BW = 100 kHz)			-36	dBm
• 174 - 230 MHz (BW = 100 kHz)			-54	dBm
• 230 - 470 MHz (BW = 100 kHz)			-36	dBm
• 470 - 862 MHz (BW = 100 kHz)			-54	dBm
• 862 - 1000 MHz (BW = 100 kHz)			-36	dBm
• 1000 - 12750 MHz (BW = 1 MHz)			-30	dBm
<b>Rx Characteristics</b>	<b>Minimum</b>	<b>Typical</b>	<b>Maximum</b>	<b>Unit</b>
Receiver sensitivity (PER < 30.8%)		-95	-70	dBm
Maximum input signal level (PER < 30.8%)	-10			dBm
PER Report Integrity (-30 dBm input)	50		65.4	%



## 14 General Regulatory Certification for LBEE5XV1YM

This section contains the following topics:

- Application model part number
- Label
- Package Label
- Country of Origin

### 14.1 Application Model Part Number

Basically, we apply for “LBEE5XV1YM” in each country.

### 14.2 Label

**Figure 16** shows the certification label of Type 1YM module.

**Figure 16: Radio Regulatory Certification Label**

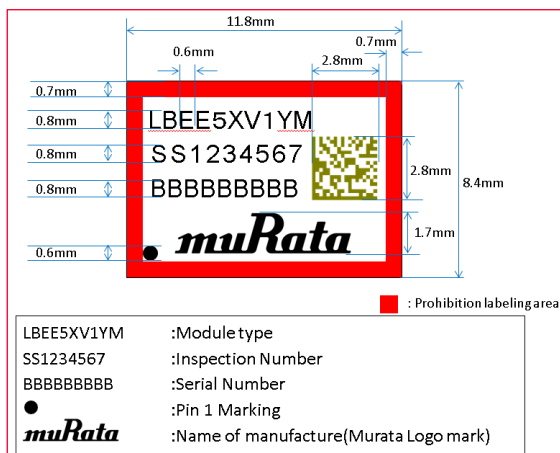

Since there is no space to describe the notational requirements of each country, we are applying for the notational requirements to be posted in the manual or package.

### 14.3 Package Label

**Figure 17** shows the package label information (Humidity Proof Packing).

**Figure 17: Package Label (Humidity proof Packing)**

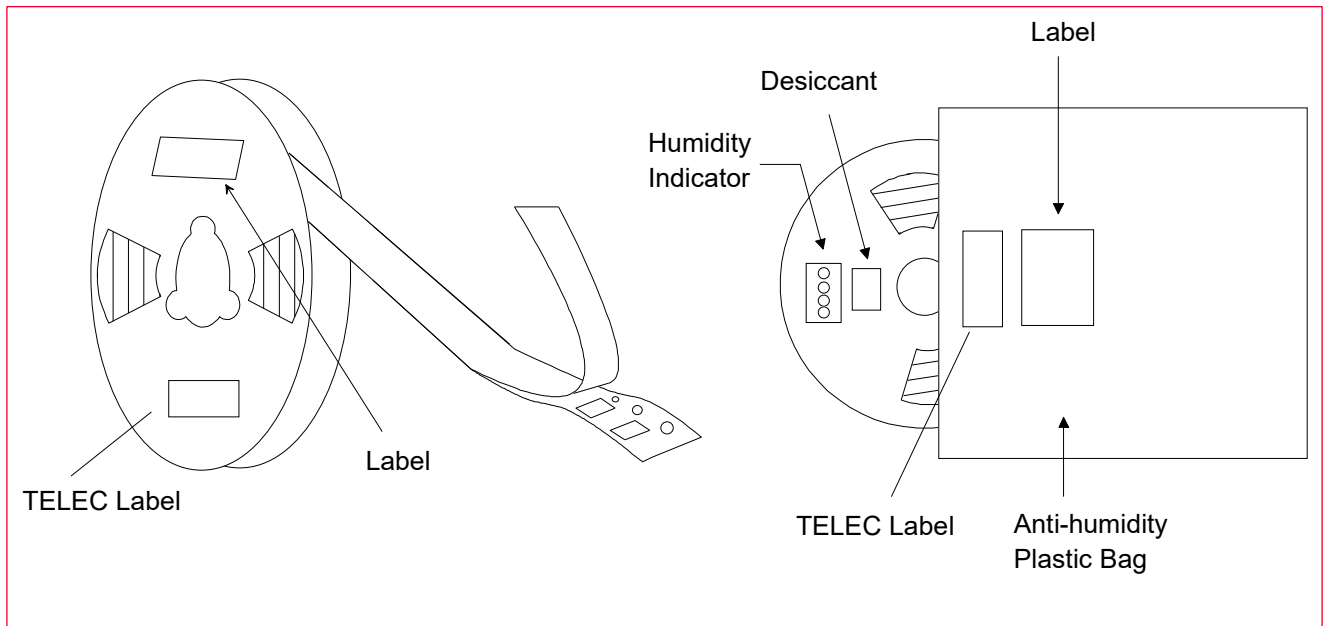

The package label may be attached on one side only.

Package label display example is shown in **Figure 18**.

**Figure 18: Package Label Display Example**



## 14.4 Country of Origin

### China

SHENZHEN MURATA TECHNOLOGY CO., LTD.

Some countries have applied for two countries, China and Japan, in preparation for future factory changes, but the production site in the delivery specifications is the above-mentioned factory in China.

## 15 Radio Regulatory Certification by Country for LBEE5XV1YM

This section includes regulatory certification information all the following countries:

- Japan
- FCC
- ISED
- Europe

### 15.1 Japan

- Manufacturer: Murata Manufacturing Co., Ltd.
- Model or Product Name: LBEE5XV1YM
- This module has received "CERTIFICATION for TYPE CERTIFICATION" under the Japanese Radio Act.

#### Japanese Version

【（警告）5GHzの周波数帯においては、5.2GHz/5.3GHz/5.6GHz帯(W52/W53/W56)の3種類の帯域を使用することができます。5.2GHz/5.3GHz帯無線LAN(W52/W53)の屋外使用は5.2GHz帯高出力データ通信システムの基地局又は陸上移動中継局と通信する場合を除き電波法で禁止されています。】

#### English Version

Warning based on the requirements of Japanese Radio Act

(Warning) In the 5GHz frequency band, you can use 3 bands: 5.2GHz/5.3GHz/5.6GHz(W52/W53/W56).

Outdoor use of 5.2GHz/5.3GHz band wireless LANs(W52/W53) is prohibited by the Radio Act except when communicating with 5.2GHz band high-power data communication system base stations or land mobile relay stations.



#### 15.1.1 Power Levels for Japan

**Table 51** and **Table 52** shows the Japan SISO, MIMO, simultaneous transmission per antenna port power table for 2.4 GHz for WLAN and Bluetooth. **Table 53**, **Table 54**, and **Table 55** shows the Japan SISO, MIMO, simultaneous transmission per antenna port power table for 5 GHz WLAN.

**Table 51: Japan Power Level 2.4 GHz WLAN Per Antenna Port**

Band	Data rate	Minimum (dBm)	Typical (dBm)	Maximum (dBm)
<b>Channels:</b>		<b>1 ~ 13</b>		
11b	1 ~ 11 Mbps	10.0	12.0	14.0
11g	6 ~ 54 Mbps	11.0	13.0	15.0



Band	Data rate	Minimum (dBm)	Typical (dBm)	Maximum (dBm)
11n HT20	MCS0 ~ MCS2	11.0	13.0	15.0
	MCS3 ~ MCS7	10.0	12.0	14.0
11ac VHT20	MCS0 ~ MCS2	11.0	13.0	15.0
	MCS3 ~ MCS7	10.0	12.0	14.0
	MCS8	9.0	11.0	13.0

Table 52: Japan Power Level 2.4 GHz BT/BLE Per Antenna Port

Standard	Data rate	Minimum (dBm)	Typical (dBm)	Maximum (dBm)
<b>Band:</b>		<b>2402 ~ 2480 MHz</b>		
BT	BR	0.0	3.0	6.0
	EDR	-3.0	0.0	3.0
BLE	1 Mbps	0.0	3.0	6.0
	2 Mbps	0.0	3.0	6.0

Table 53: Japan Power Level 5 GHz WLAN Per Antenna Port (W52)

Band	Data rate	Minimum (dBm)	Typical (dBm)	Maximum (dBm)
<b>Channels:</b>		<b>36 ~ 48</b>		
11a	6 ~ 54 Mbps	8.0	10.0	12.0
11n HT20	MCS0 ~ MCS7	8.0	10.0	12.0
11ac VHT20	MCS0 ~ MCS8	8.0	10.0	12.0

Table 54: Japan Power Level 5 GHz WLAN Per Antenna Port (W53)

Band	Data rate	Minimum (dBm)	Typical (dBm)	Maximum (dBm)
<b>Channels:</b>		<b>52 ~ 64</b>		
11a	6 ~ 54 Mbps	8.0	10.0	12.0
11n HT20	MCS0 ~ MCS7	8.0	10.0	12.0
11ac VHT20	MCS0 ~ MCS8	8.0	10.0	12.0

Table 55: Japan Power Level 5 GHz WLAN Per Antenna Port (W56)

Band	Data rate	Minimum (dBm)	Typical (dBm)	Maximum (dBm)
<b>Channels:</b>		<b>100 ~ 144</b>		
11a	6 ~ 18 Mbps	11.0	13.0	15.0
	24 ~ 54 Mbps	10.0	12.0	14.0
11n HT20	MCS0 ~ MCS2	11.0	13.0	15.0
	MCS3 ~ MCS7	9.0	11.0	13.0
11ac VHT20	MCS0 ~ MCS2	11.0	13.0	15.0
	MCS3 ~ MCS7	9.0	11.0	13.0
	MCS8	8.0	10.0	12.0
<b>Channels:</b>		<b>102 ~ 142</b>		
11n HT40	MCS0 ~ MCS2	11.0	13.0	15.0
	MCS3 ~ MCS7	9.0	11.0	13.0

Band	Data rate	Minimum (dBm)	Typical (dBm)	Maximum (dBm)
11ac VHT40	MCS0 ~ MCS2	11.0	13.0	15.0
	MCS3 ~ MCS7	9.0	11.0	13.0
	MCS8 ~ MCS9	8.0	10.0	12.0
<b>Channels:</b>		<b>106 ~ 138</b>		
11ac VHT80	MCS0 ~ MCS2	10.0	12.0	14.0
	MCS3 ~ MCS7	9.0	11.0	13.0
	MCS8 ~ MCS9	8.0	10.0	12.0

- Two Antenna Ports
  - With simultaneous transmission of SISO×2 and MIMO.
  - The typical values in the above table are all "setting values". Same value for SISO×1, SISO×2, and MIMO. Therefore, in the case of SISO×2 or MIMO, the output power (theoretical value) is 3 dBm higher than that of SISO×1.
  - Setting value is typical, WLAN deviation is ±2 dB, BT/BLE deviation is ±3 dB.

### 15.1.2 Antenna List

Table 56 presents the registered antennas for Type 1YM.

Table 56: Antenna Registered Under the Japan Radio Act

No.	Maker	Support Antenna						Detail
		P/N	Form factor	Type	Gain		Size	
					2.4 GHz	5 GHz		
1	Molex	146153	u.FL/flexible	Dipole	3.2	4.25	35x9x0.1 mm	flexible//horizontal
2	Molex	146187	u.FL/flexible	Dipole	3.4	4.75	40.95x9x0.7 mm	rigid//horizontal
3	Molex	206994	u.FL/flexible	Monopole	3.6	3.6	15.4x6.4x0.15 mm	adhesive // flexible //vertical

### 15.1.3 About Notations

It is recommended that the indication of (1) or (2) below is described on the product incorporating this module in Japanese. If there is any problem with the indication of (1) or (2) on the product, we recommend indicating (1) or (2) in the user manual or on the package of the product incorporating this module, or electronic display on the product. In the case of the electronic display, it is necessary to describe "using the electronic display" + "how to reach to below indication" in the user manual of the product.

- Recommended Indication 1

<p><b>Japanese Version</b>            本製品は、電波法に基づく工事設計認証(認証番号:001-P01563)を受けた特定無線設備を内蔵しています。</p>
<p><b>English Version</b>            This product incorporates specified radio equipment that has received CERTIFICATION for TYPE CERTIFICATION (certification number: 001-P01563) based on the Japan Radio Act.</p>

- Recommended Indication 2

## Japanese Version

 R 001-P01563

5.2GHz/5.3GHz 帯無線 LAN(W52/W53)の屋外使用は 5.2GHz 帯高出力データ通信システムの基地局又は陸上移動中継局と通信する場合を除き電波法で禁止されています。

## English Version

Outdoor use of 5.2GHz/5.3GHz band wireless LANs (W52/W53) is prohibited by the Radio Act except when communicating with 5.2GHz band high-power data communication system base stations or land mobile relay stations.

## 15.2 FCC

### FCC ID: VPYLB1YM

This module is not directly sold to general end users. Therefore, there is no user manual of module. For the details about this module, please refer to the specification sheet of the module.



1. This module should be installed in the host device according to the interface specification (installation procedure).
2. This device complies with part 15 of the FCC Rules. Operation is subject to the following two conditions:(1) This device may not cause harmful interference, and (2) this device must accept any interference received, including interference that may cause undesired operation.
3. This device complies with below part 15 of FCC Rules.
  - Part 15 Subpart C
  - Part 15 Subpart E
4. The modular transmitter is only FCC authorized for the specific rule parts (i.e., FCC transmitter rules) listed on the grant, and the host product manufacturer is responsible for compliance to any other FCC rules that apply to the host not covered by the modular transmitter grant of certification. The final host product still requires Part 15 Subpart B compliance testing with the modular transmitter installed.
5. This module designed for mounting inside of the end product by us professionally. Therefore, it complies with the antenna and transmission system requirements of §15.203.
6. Since there is no space which indicates FCC ID on this module, FCC ID is indicated in a manual. If the FCC ID is not visible when the module is installed inside another device, then the module is installed must also display a label referring to the enclosed module.

### 15.2.1 Supply Voltage

Table 57 shows the supply voltage information.

Table 57: Supply Voltage

DUT PIN Name	Minimum	Typical	Maximum	Unit
VBAT <sup>11</sup>	2.7	3.3	5.5	V
VIO	1.62 2.25 2.97	1.8 2.5 3.3	1.98 2.75 3.47	V
VIO_SD	1.62 2.97	1.8 3.3	1.98 3.47	V
AVDD33	2.97	3.3	3.47	V
VDDIO_AO <sup>12</sup>	3.14 / 1.71	3.3 / 1.8	3.46 / 1.89	V

<sup>11</sup> Only this power supply affects the RF characteristics.

<sup>12</sup> VBAT: Only this power supply affects the RF characteristics.

## 15.2.2 Power Level for FCC

**Table 58** and **Table 59** shows FCC SISO, MIMO, simultaneous transmission per antenna port power table for 2.4 GHz for WLAN and Bluetooth. **Table 60** shows the FCC SISO, MIMO, simultaneous transmission per antenna port power table for 5 GHz WLAN.

**Table 58: FCC Power Level 2.4 GHz WLAN Per Antenna Port**

Mode	Band	Channel	Rate	Maximum Tune Up Tolerance [dBm]
IEEE 802.11b	2.4 GHz	1~11	All Rates	13.0 ± 2.0
IEEE 802.11g	2.4 GHz	1, 2, 10, 11	All Rates	10.0 ± 2.0
		3~9	6 Mbps, 9 Mbps, 12 Mbps, 18 Mbps	16.0 ± 2.0
			24 Mbps, 36 Mbps, 48 Mbps, 54 Mbps	13.0 ± 2.0
IEEE 802.11n (HT20)	2.4 GHz	1, 2, 10, 11	All Rates	10.0 ± 2.0
		3~9	MCS0 ~ MCS2	15.0 ± 2.0
			MCS3 ~ MCS7	12.0 ± 2.0
IEEE 802.11ac (VHT20)	2.4 GHz	1, 2, 10, 11	All Rates	10.0 ± 2.0
		3~9	VHT_SS1_MCS0 ~ VHT_SS1_MCS2	15.0 ± 2.0
			VHT_SS1_MCS3 ~ VHT_SS1_MCS7	12.0 ± 2.0
			VHT_SS1_MCS8	11.0 ± 2.0

**Table 59: FCC Power Level 2.4 GHz BT/BLE Per Antenna Port**

Mode	Maximum Tune Up Tolerance [dBm]
BR	3.0 ± 3.0
EDR	0.0 ± 3.0
LE	3.0 ± 3.0
LE 2 Mbps	3.0 ± 3.0

**Table 60: FCC Power Level 5 GHz WLAN Per Antenna Port**

Mode	Band	Channel	Rate	Maximum Tune Up Tolerance [dBm]
IEEE 802.11a	W52	36~48	All Rates	8.0 ± 2.0
		W53	52~60	6 Mbps, 9 Mbps, 12 Mbps, 18 Mbps
	3~9		24 Mbps, 36 Mbps, 48 Mbps, 54 Mbps	12.0 ± 2.0
			64	All Rates
	W56	100	All Rates	9.0 ± 2.0
		104~136, 144	6 Mbps, 9 Mbps, 12 Mbps, 18 Mbps	14.0 ± 2.0
			24 Mbps, 36 Mbps, 48 Mbps, 54 Mbps	10.0 ± 2.0
	140	All Rates	7.0 ± 2.0	
W58	149~165	6 Mbps, 9 Mbps, 12 Mbps, 18 Mbps	15.0 ± 2.0	
		24 Mbps, 36 Mbps, 48 Mbps, 54 Mbps	12.0 ± 2.0	
IEEE 802.11n (HT20)	W52	36~48	All Rates	8.0 ± 2.0
		W53	52~60	MCS0 ~ MCS2
	MCS3 ~ MCS7		11.0 ± 2.0	

Mode	Band	Channel	Rate	Maximum Tune Up Tolerance [dBm]		
	W56	64	All Rates	10.0 ± 2.0		
		100	All Rates	9.0 ± 2.0		
		104~136, 144	MCS0 ~ MCS2 MCS3 ~ MCS7	14.0 ± 2.0 11.0 ± 2.0		
		140	All Rates	7.0 ± 2.0		
	W58	149~165	MCS0 ~ MCS2 MCS3 ~ MCS7	15.0 ± 2.0 11.0 ± 2.0		
IEEE 802.11n (HT40)	W52	38	All Rates	7.0 ± 2.0		
		46	All Rates	10.0 ± 2.0		
	W53	54	MCS0 ~ MCS2 MCS3 ~ MCS7	13.0 ± 2.0 11.0 ± 2.0		
			62	All Rates	7.0 ± 2.0	
	W56	102	All Rates	7.0 ± 2.0		
		110~126, 142	MCS0 ~ MCS2 MCS3 ~ MCS7	13.0 ± 2.0 11.0 ± 2.0		
			134	All Rates	10.0 ± 2.0	
	W58	151	MCS0 ~ MCS2	13.0 ± 2.0		
		159	MCS3 ~ MCS7	14.0 ± 2.0		
		151~159	All Rates	11.0 ± 2.0		
	IEEE 802.11ac (VHT20)	W52	36~48	All Rates	8.0 ± 2.0	
		W53	52~60	VHT_SS1_MCS0 ~ VHT_SS1_MCS2 VHT_SS1_MCS3 ~ VHT_SS1_MCS7 VHT_SS1_MCS8	14.0 ± 2.0 11.0 ± 2.0 10.0 ± 2.0	
64				All Rates	9.0 ± 2.0	
W56				104~144	VHT_SS1_MCS0 ~ VHT_SS1_MCS2 VHT_SS1_MCS3 ~ VHT_SS1_MCS7 VHT_SS1_MCS8	14.0 ± 2.0 11.0 ± 2.0 10.0 ± 2.0
		W58	149~165		VHT_SS1_MCS0 ~ VHT_SS1_MCS2 VHT_SS1_MCS3 ~ VHT_SS1_MCS7 VHT_SS1_MCS8	15.0 ± 2.0 11.0 ± 2.0 10.0 ± 2.0
IEEE 802.11ac (VHT40)		W52	38	All Rates	7.0 ± 2.0	
			46	All Rates	10.0 ± 2.0	
		W53	54	VHT_SS1_MCS0 ~ VHT_SS1_MCS2 VHT_SS1_MCS3 ~ VHT_SS1_MCS7 VHT_SS1_MCS8, VHT_SS1_MCS9	13.0 ± 2.0 11.0 ± 2.0 10.0 ± 2.0	
				62	All Rates	7.0 ± 2.0
				W56	110~142	VHT_SS1_MCS0 ~ VHT_SS1_MCS2 VHT_SS1_MCS3 ~ VHT_SS1_MCS7 VHT_SS1_MCS8, VHT_SS1_MCS9
	W58	151~159	VHT_SS1_MCS0 ~ VHT_SS1_MCS2 VHT_SS1_MCS3 ~ VHT_SS1_MCS7 VHT_SS1_MCS8, VHT_SS1_MCS9			7.0 ± 2.0 13.0 ± 2.0 11.0 ± 2.0 10.0 ± 2.0
	IEEE 802.11ac (VHT80)	W52	42	All Rates	5.0 ± 2.0	
		W53	58	All Rates	5.0 ± 2.0	
		W56	106	All Rates	5.0 ± 2.0	
			122, 138	VHT_SS1_MCS0 ~ VHT_SS1_MCS2 VHT_SS1_MCS3 ~ VHT_SS1_MCS7 VHT_SS1_MCS8, VHT_SS1_MCS9	12.0 ± 2.0 11.0 ± 2.0 10.0 ± 2.0	

Mode	Band	Channel	Rate	Maximum Tune Up Tolerance [dBm]
	W58	155	VHT_SS1_MCS0 ~ VHT_SS1_MCS2	13.0 ± 2.0
			VHT_SS1_MCS3 ~ VHT_SS1_MCS7	11.0 ± 2.0
			VHT_SS1_MCS8, VHT_SS1_MCS9	10.0 ± 2.0

### 15.2.3 Theory of Operation for FCC

**Table 61** shows the theory of operation tables for WLAN and Bluetooth.

**Table 61: FCC Theory of Operation for WLAN**

Frequency of Operation			Scan	Ad-hoc mode
2.4 GHz	11b/g/n (HT20)/ac (VHT20)	2412-2462 MHz	Active	Yes
W52	11a/n/ac ((V)HT20)	5180-5240 MHz	Active	Yes
	11n/ac ((V)HT40)	5190-5230 MHz	Active	Yes
	11ac (VHT80)	5210 MHz	Active	Yes
W53	11a/n/ac ((V)HT20)	5260-5320 MHz	Passive	No
	11n/ac ((V)HT40)	5270-5310 MHz	Passive	No
	11ac (VHT80)	5290 MHz	Passive	No
W56	11a/n/ac ((V)HT20)	5500-5720 MHz <sup>13</sup>	Passive	No
	11n/ac ((V)HT40)	5510-5710 MHz <sup>13</sup>	Passive	No
	11ac (VHT80)	5530-5690 MHz <sup>13</sup>	Passive	No
W58	11a/n/ac ((V)HT20)	5745-5825 MHz	Active	Yes
	11n/ac ((V)HT40)	5755-5795 MHz	Active	Yes
	11ac (VHT80)	5775 MHz	Active	Yes

### 15.2.4 Information to Include in the User Manual

The following statements must be described on the user manual of the host device of this module.

- Contains Transmitter Module FCC ID: VPYLB1YM or Contains FCC ID: VPYLB1YM



This device complies with part 15 of the FCC Rules. Operation is subject to the following two conditions:

- This device may not cause harmful interference
- This device must accept any interference received, including interference that may cause undesired operation.



If it is difficult to describe this statement on the host product due to the size, please describe in the User's manual.

- **FCC CAUTION:** Changes or modifications not expressly approved by the party responsible for compliance could void the user's authority to operate the equipment.

<sup>13</sup> ISD:5600-5650 MHz disable

- This transmitter must not be co-located or operated in conjunction with any other antenna or transmitter.

### 15.2.5 Compliance with FCC requirement 15.407(c)

Data transmission is always initiated by software, which is then passed down through the MAC, through the digital and analog baseband, and finally to the RF chip. Several special packets are initiated by the MAC. These are the only ways the digital baseband portion will turn on the RF transmitter, which it then turns off at the end of the packet. Therefore, the transmitter will be on only while one of the aforementioned packets is being transmitted. In other words, this device automatically discontinues transmission in case of either absence of information to transmit or operational failure.



Frequency Tolerance:  $\pm 20$  ppm

### 15.2.6 Equipment Installation for FCC

There are two types of installation for host device.

#### 15.2.6.1 Portable Equipment

Equipment for which the spaces between human body and antenna are used within 20 cm. When installing it in a portable equipment. Please describe the following warning to the manual.



The available scientific evidence does not show that any health problems are associated with using low power wireless devices. There is no proof, however, that these low power wireless devices are absolutely safe. Low power Wireless devices emit low levels of radio frequency energy (RF) in the microwave range while being used. Whereas high levels of RF can produce health effects (by heating tissue), exposure of low-level RF that does not produce heating effects causes no known adverse health effects. Many studies of low-level RF exposures have not found any biological effects. Some studies have suggested that some biological effects might occur, but such findings have not been confirmed by additional research. Type1YM has been tested and found to comply with FCC radiation exposure limits set forth for an uncontrolled environment and meets the FCC radio frequency (RF) Exposure Guidelines.



It is necessary to take a SAR test with your set mounting this module (except to use only Bluetooth). Class II permissive change application is necessary using the SAR report. Please contact Murata.

#### 15.2.6.2 Mobile Equipment

Equipment used at position in which the spaces between human body and antenna exceeded 20 cm. When installing it in a mobile equipment. Please describe the following warning to the manual.



This equipment complies with FCC radiation exposure limits set forth for an uncontrolled environment and meets the FCC radio frequency (RF) Exposure Guidelines. This equipment should be installed and operated keeping the radiator at least 20 cm or more away from person's body.

## 15.3 ISED

HVIN : LBEE5XV1YM

PMN : LBEE5XV1YM

IC Number: 772C-LB1YM

This module is not sold to general end users directly. Therefore, there is no user manual of module. For details about this module, please refer to the specification sheet of module.



This module should be installed in the host device according to the interface specification (installation procedure).

### 15.3.1 Information to Display on Host Device and User Manual

#### 15.3.1.1 Information on Host Device

The following information must be indicated on the host device of this module.

- Contains IC: 772C-LB1YM

#### 15.3.1.2 Information in User Manual

The following statements must be described on the user manual of the host device of this module.

##### English Version

This device complies with Industry Canada's applicable licence-exempt RSSs. Operation is subject to the following two conditions:

- This device may not cause interference
- This device must accept any interference, including interference that may cause undesired operation of the device.

##### French Version

Le présent appareil est conforme aux CNR d'Industrie Canada applicables aux appareils radio exempts de licence. L'exploitation est autorisée aux deux conditions suivantes :

- l'appareil ne doit pas produire de brouillage;
- l'utilisateur de l'appareil doit accepter tout brouillage radioélectrique subi, même si le brouillage est susceptible d'en compromettre le fonctionnement.

##### English Version

Data transmission is always initiated by software, which is then passed down through the MAC, through the digital and analog baseband, and finally to the RF chip. Several special packets are initiated by the MAC. These are the only ways the digital baseband portion will turn on the RF transmitter, which it then turns off at the end of the packet. Therefore, the transmitter will be on only while one of the aforementioned packets is being transmitted. In other words, this device automatically discontinues transmission in case of either absence of information to transmit or operational failure.

##### French Version

La transmission des données est toujours initiée par le logiciel, puis les données sont transmises par l'intermédiaire du MAC, par la bande de base numérique et analogique et, enfin, à la puce RF. Plusieurs paquets spéciaux sont initiés par le MAC. Ce sont les seuls moyens pour qu'une partie de la bande de base numérique active l'émetteur RF, puis désactive celui-ci à la fin du paquet. En conséquence, l'émetteur reste uniquement activé lors de la transmission d'un des paquets susmentionnés. En d'autres termes, ce dispositif interrompt automatiquement toute transmission en cas d'absence d'information à transmettre ou de défaillance.



If it is difficult to describe this statement on the host product due to the size, please describe in the User's manual.



In case of the final product which can be carried around to outdoor, the following indication is necessary to the final product.

- When the AP function is used in W52.
  - At the time of a channel setting of W52, please indicate "for indoor use only". During connecting, please show the channel number which connects.
  - And please indicate that the end user may find out "for indoor use only channel".
- When the STA function is used in channel 52, 54, 58, at the time of the channel 52 or 54 or 58 setting, please indicate "for indoor use only channel".
  - During connecting, please show the channel number which connects.
  - And please indicate that the end user may find out "for indoor use only channel".

### 15.3.2 Antenna Installation in End Product

If the antenna of the end product is removed, please describe the follow warning on the manual of the end product which contains this module.

#### English Version

This radio transmitter (IC Number: 772C-LB1YM) identify the device by certification number or model number if Category II) has been approved by Industry Canada to operate with the antenna types listed below with the maximum permissible gain indicated. Antenna types not included in this list, having a gain greater than the maximum gain indicated for that type, are strictly prohibited for use with this device.

#### Chain0 & Chain1

: 2.4GHz	146153	Dual Dipole antenna	Gain: +3.2 dBi
: 5GHz	146153	Dual Dipole antenna	Gain: +4.25 dBi
: 2.4GHz	146187	Dual Dipole antenna	Gain: +3.4 dBi
: 5GHz	146187	Dual Dipole antenna	Gain: +4.75 dBi

#### French Version

Le présent émetteur radio (IC Number : 772C-LB1YM) a été approuvé par Industrie Canada pour fonctionner avec les types d'antenne énumérés ci dessous et ayant un gain admissible maximal. Les types d'antenne non inclus dans cette liste, et dont le gain est supérieur au gain maximal indiqué, sont strictement interdits pour l'exploitation de l'émetteur.

#### Type d'antenne

#### Chain0 & Chain1

: 2.4GHz	146153	Dual Dipole antenna	Gain: +3.2 dBi
: 5GHz	146153	Dual Dipole antenna	Gain: +4.25 dBi
: 2.4GHz	146187	Dual Dipole antenna	Gain: +3.4 dBi
: 5GHz	146187	Dual Dipole antenna	Gain: +4.75 dBi

If the final product uses the following frequency, please note that there is a limit.

#### English Version

For indoor use only (5150-5250 MHz band and channel 52, 54, 58)

#### French Version

Pour usage intérieur seulement (5150-5250 MHz band and channel 52, 54, 58)

### 15.3.3 Equipment Installation for ISED

There are two types of installation for host device.

#### 15.3.3.1 Portable Equipment

Equipment for which the spaces between human body and antenna are used within 20 cm.

When installing it in a portable equipment. Please describe the following warning to the manual.

##### English Version

The available scientific evidence does not show that any health problems are associated with using low power wireless devices. There is no proof, however, that these low power wireless devices are absolutely safe. Low power Wireless devices emit low levels of radio frequency energy (RF) in the microwave range while being used. Whereas high levels of RF can produce health effects (by heating tissue), exposure of low-level RF that does not produce heating effects causes no known adverse health effects. Many studies of low-level RF exposures have not found any biological effects. Some studies have suggested that some biological effects might occur, but such findings have not been confirmed by additional research. Type1YM has been tested and found to comply with IC radiation exposure limits set forth for an uncontrolled environment and meets RSS-102 of the IC radio frequency (RF) Exposure rules.

##### French Version

Les connaissances scientifiques dont nous disposons n'ont mis en évidence aucun problème de santé associé à l'usage des appareils sans fil à faible puissance. Nous ne sommes cependant pas en mesure de prouver que ces appareils sans fil à faible puissance sont entièrement sans danger. Les appareils sans fil à faible puissance émettent une énergie fréquence radioélectrique (RF) très faible dans le spectre des micro-ondes lorsqu'ils sont utilisés. Alors qu'une dose élevée de RF peut avoir des effets sur la santé (en chauffant les tissus), l'exposition à de faibles RF qui ne produisent pas de chaleur n'a pas de mauvais effets connus sur la santé. De nombreuses études ont été menées sur les expositions aux RF faibles et n'ont découvert aucun effet biologique. Certaines études ont suggéré qu'il pouvait y avoir certains effets biologiques, mais ces résultats n'ont pas été confirmés par des recherches supplémentaires. Type1YM a été testé et jugé conforme aux limites d'exposition aux rayonnements IC énoncées pour un environnement non contrôlé et respecte les règles d'exposition aux fréquences radioélectriques (RF) CNR-102 de l'IC



It is necessary to take a SAR test with your set mounting this module.

Class 4 permissive change application is necessary using the SAR report. Please contact Murata.

#### 15.3.3.2 Mobile Equipment

Equipment used at position in which the spaces between human body and antenna exceeded 20 cm. When installing it in a mobile equipment. Please describe the following warning to the manual.

##### English Version

This equipment complies with IC radiation exposure limits set forth for an uncontrolled environment and meets RSS-102 of the IC radio frequency (RF) Exposure rules. This equipment should be installed and operated keeping the radiator at least 20 cm or more away from person's body.

##### French Version

Cet équipement est conforme aux limites d'exposition aux rayonnements énoncées pour un environnement non contrôlé et respecte les règles d'exposition aux fréquences radioélectriques (RF) CNR-102 de l'IC. Cet équipement doit être installé et utilisé en gardant une distance de 20 cm ou plus entre le radiateur et le corps humain.

### 15.3.4 Power Level for ISED

**Table 62** and **Table 63** show the IC SISO, MIMO, simultaneous transmission per antenna port power table for 2.4 GHz for WLAN and Bluetooth. **Table 64** shows the IC SISO, MIMO, simultaneous transmission per antenna port power table for 5 GHz WLAN.

Table 62: ISED Power Level 2.4 GHz WLAN Per Antenna Port

Mode	Band	Channel	Rate	Maximum Tune Up Tolerance [dBm]
IEEE 802.11b	2.4 GHz	1~11	All Rate	13.0 ± 2.0
IEEE 802.11g	2.4 GHz	1, 2, 10, 11	All Rate	10.0 ± 2.0
		3~9	6 Mbps, 9 Mbps, 12 Mbps, 18 Mbps	16.0 ± 2.0
			24 Mbps, 36 Mbps, 48 Mbps, 54 Mbps	13.0 ± 2.0
IEEE 802.11n (HT20)	2.4 GHz	1, 2, 10, 11	All Rate	10.0 ± 2.0
		3~9	MCS0 ~ MCS2	15.0 ± 2.0
			MCS3 ~ MCS7	12.0 ± 2.0
IEEE 802.11ac (VHT20)	2.4 GHz	1, 2, 10, 11	All Rate	10.0 ± 2.0
		3~9	VHT_SS1_MCS0 ~ VHT_SS1_MCS2	15.0 ± 2.0
			VHT_SS1_MCS3 ~ VHT_SS1_MCS7	12.0 ± 2.0
			VHT_SS1_MCS8	11.0 ± 2.0

Table 63: ISED Power Level 2.4 GHz BT/BLE Per Antenna Port

Mode	Maximum Tune Up Tolerance [dBm]
BR	3.0 ± 3.0
EDR	0.0 ± 3.0
LE	3.0 ± 3.0
LE 2 Mbps	3.0 ± 3.0

Table 64: ISED Power Level 5 GHz WLAN Per Antenna Port

Mode	Band	Channel	Rate	Maximum Tune Up Tolerance [dBm]
IEEE 802.11a	W52	36~48	All Rates	8.0 ± 2.0
		W53	52~60	6 Mbps, 9 Mbps, 12 Mbps, 18 Mbps
	3~9 64		24 Mbps, 36 Mbps, 48 Mbps, 54 Mbps	12.0 ± 2.0
			All Rates	10.0 ± 2.0
	W56	100	All Rates	9.0 ± 2.0
		104~136, 144	6 Mbps, 9 Mbps, 12 Mbps, 18 Mbps	14.0 ± 2.0
			24 Mbps, 36 Mbps, 48 Mbps, 54 Mbps	10.0 ± 2.0
		Not including 120~128		
	140	All Rates	7.0 ± 2.0	
	W58	149~165	6 Mbps, 9 Mbps, 12 Mbps, 18 Mbps	15.0 ± 2.0
24 Mbps, 36 Mbps, 48 Mbps, 54 Mbps			12.0 ± 2.0	
IEEE 802.11n (HT20)	W52	36~48	All Rates	8.0 ± 2.0
		W53	52~60	MCS0 ~ MCS2
			MCS3 ~ MCS7	11.0 ± 2.0
	64		All Rates	10.0 ± 2.0
	W56	100	All Rates	9.0 ± 2.0
		104~136, 144	MCS0 ~ MCS2	14.0 ± 2.0
	MCS3 ~ MCS7		11.0 ± 2.0	

Mode	Band	Channel	Rate	Maximum Tune Up Tolerance [dBm]		
		Not including 120~128				
		140	All Rates	7.0 ± 2.0		
	W58	149~165	MCS0 ~ MCS2	15.0 ± 2.0		
			MCS3 ~ MCS7	11.0 ± 2.0		
IEEE 802.11n (HT40)	W52	38	All Rates	7.0 ± 2.0		
		46	All Rates	10.0 ± 2.0		
	W53	54	MCS0 ~ MCS2	13.0 ± 2.0		
			MCS3 ~ MCS7	11.0 ± 2.0		
		62	All Rates	7.0 ± 2.0		
	W56	102	All Rates	7.0 ± 2.0		
		110,142	MCS0 ~ MCS2	13.0 ± 2.0		
			MCS3 ~ MCS7	11.0 ± 2.0		
	W58	134	All Rates	10.0 ± 2.0		
			151	MCS0 ~ MCS2	13.0 ± 2.0	
				MCS3 ~ MCS7	14.0 ± 2.0	
		151~159	All Rates	11.0 ± 2.0		
IEEE 802.11ac (VHT20)			W52	36~48	All Rates	8.0 ± 2.0
				W53	52~60	VHT_SS1_MCS0 ~ VHT_SS1_MCS2
	VHT_SS1_MCS3 ~ VHT_SS1_MCS7	11.0 ± 2.0				
	VHT_SS1_MCS8	10.0 ± 2.0				
64	All Rates	9.0 ± 2.0				
	W56	100	All Rates	9.0 ± 2.0		
104~144 Not including 120~128			VHT_SS1_MCS0 ~ VHT_SS1_MCS2	14.0 ± 2.0		
			VHT_SS1_MCS3 ~ VHT_SS1_MCS7	11.0 ± 2.0		
	VHT_SS1_MCS8	10.0 ± 2.0				
W58	149~165	VHT_SS1_MCS0 ~ VHT_SS1_MCS2	15.0 ± 2.0			
		VHT_SS1_MCS3 ~ VHT_SS1_MCS7	11.0 ± 2.0			
		VHT_SS1_MCS8	10.0 ± 2.0			
IEEE 802.11ac (VHT40)	W52	38	All Rates	7.0 ± 2.0		
		46	All Rates	10.0 ± 2.0		
	W53	54	VHT_SS1_MCS0 ~ VHT_SS1_MCS2	13.0 ± 2.0		
			VHT_SS1_MCS3 ~ VHT_SS1_MCS7	11.0 ± 2.0		
			VHT_SS1_MCS8, VHT_SS1_MCS9	10.0 ± 2.0		
	62	All Rates	7.0 ± 2.0			
		W56	102	All Rates	7.0 ± 2.0	
	110,134,142			VHT_SS1_MCS0 ~ VHT_SS1_MCS2	13.0 ± 2.0	
				VHT_SS1_MCS3 ~ VHT_SS1_MCS7	11.0 ± 2.0	
		VHT_SS1_MCS8, VHT_SS1_MCS9	10.0 ± 2.0			
	W58	151~159	VHT_SS1_MCS0 ~ VHT_SS1_MCS2	13.0 ± 2.0		
			VHT_SS1_MCS3 ~ VHT_SS1_MCS7	11.0 ± 2.0		
VHT_SS1_MCS8, VHT_SS1_MCS9			10.0 ± 2.0			
IEEE 802.11ac (VHT80)	W52	42	All Rates	5.0 ± 2.0		
		W53	58	All Rates	5.0 ± 2.0	
	W56			106	All Rates	5.0 ± 2.0
		138	VHT_SS1_MCS0 ~ VHT_SS1_MCS2		12.0 ± 2.0	
			VHT_SS1_MCS3 ~ VHT_SS1_MCS7		11.0 ± 2.0	
	VHT_SS1_MCS8, VHT_SS1_MCS9		10.0 ± 2.0			
	W58	155	VHT_SS1_MCS0 ~ VHT_SS1_MCS2	13.0 ± 2.0		
			VHT_SS1_MCS3 ~ VHT_SS1_MCS7	11.0 ± 2.0		
VHT_SS1_MCS8, VHT_SS1_MCS9			10.0 ± 2.0			

### 15.3.5 Theory of Operation for ISED

**Table 65** shows the theory of operation tables for WLAN and Bluetooth.

**Table 65: ISED Theory of Operation for WLAN**

Frequency of Operation			Scan	Ad-hoc mode
2.4 GHz	11b/g/n (HT20)/ac (VHT20)	2412-2462 MHz	Active	Yes
W52	11a/n/ac ((V)HT20)	5180-5240 MHz	Active	Yes
	11n/ac ((V)HT40)	5190-5230 MHz	Active	Yes
	11ac (VHT80)	5210 MHz	Active	Yes
W53	11a/n/ac ((V)HT20)	5260-5320 MHz	Passive	No
	11n/ac ((V)HT40)	5270-5310 MHz	Passive	No
	11ac (VHT80)	5290 MHz	Passive	No
W56	11a/n/ac ((V)HT20)	5500-5720 MHz <sup>14</sup>	Passive	No
	11n/ac ((V)HT40)	5510-5710 MHz <sup>14</sup>	Passive	No
	11ac (VHT80)	5530-5690 MHz <sup>14</sup>	Passive	No
W58	11a/n/ac ((V)HT20)	5745-5825 MHz	Active	Yes
	11n/ac ((V)HT40)	5755-5795 MHz	Active	Yes
	11ac (VHT80)	5775 MHz	Active	Yes

<sup>14</sup> ISED:5600-5650 MHz disable

## 15.4 Europe

Product name: Communication Module

Model: LBEE5XV1YM

Manufacturer: Murata Manufacturing Co.Ltd.



When shipping final products with this module to Europe, make a self-declaration that the final product complies with European regulations and apply the CE mark.

The following standard reports have been published:

- EN 300 328 V2.2.2:2019
- EN 301 893 V2.1.1:2017
- EN 300 440 V2.1.1:2017
- EN 62311:2008

These reports can be leveraged as part of the TCF of the final product. We believe that the conducted test can be used directly as the TCF of the final product. The radiated test as TCF for the final product should be performed by you again with the final product.

### 15.4.1 Power Level for Europe

**Table 66** shows the maximum radio frequency power to transmit within the operating frequency band.

**Table 66: Maximum Radio Frequency Power - All Band**

Band	Maximum Radio Frequency Power [dBm E.I.R.P]
2.4 GHz	16.4
W52	19.75
W53	19.75
W56	8.75

**Table 67** shows the EU SISO, MIMO simultaneous transmission per antenna port power table for 2.4 GHz WLAN.

**Table 67: Europe Power Level 2.4 GHz WLAN Per Antenna port**

Mode	Band	Channel	Data Rate	Maximum Tune Up Tolerance [dBm]
IEEE 802.11b	2.4 GHz	1~13	All Rates	11.0 ± 2.0
IEEE 802.11g	2.4 GHz	1~13	All Rates	11.0 ± 2.0
IEEE 802.11n (HT20)	2.4 GHz	1~13	All Rates	11.0 ± 2.0
IEEE 802.11ac (VHT20)	2.4 GHz	1~13	All Rates	11.0 ± 2.0

**Table 68** shows the EU SISO, MIMO simultaneous transmission per antenna port power table for 2.4 GHz Bluetooth.

**Table 68: Europe Power Level 2.4 GHz BT/BLE Per Antenna port**

Mode	Maximum Tune Up Tolerance [dBm]
BR	3.0 ± 3.0
EDR	0.0 ± 3.0
LE	3.0 ± 3.0
LE 2 Mbps	3.0 ± 3.0

**Table 69** shows the EU SISO, MIMO simultaneous transmission per antenna port power table for 5 GHz WLAN.

**Table 69: Europe Power Level 5 GHz WLAN Per Antenna port**

Mode	Band	Channel	Rate	Maximum Tune Up Tolerance [dBm]	
IEEE 802.11a	W52	36~48	6 Mbps, 9 Mbps, 12 Mbps, 18 Mbps	13.0 ± 2.0	
			24 Mbps, 36 Mbps, 48 Mbps, 54 Mbps	12.0 ± 2.0	
	W53	52~60	6 Mbps, 9 Mbps, 12 Mbps, 18 Mbps	13.0 ± 2.0	
			24 Mbps, 36 Mbps, 48 Mbps, 54 Mbps	12.0 ± 2.0	
	W56	100~140	6 Mbps, 9 Mbps, 12 Mbps, 18 Mbps	13.0 ± 2.0	
			24 Mbps, 36 Mbps, 48 Mbps, 54 Mbps	12.0 ± 2.0	
	W58	149~169	All Rates	4.0 ± 2.0	
	IEEE 802.11n (HT20)	W52	36~48	MCS0 ~ MCS2	13.0 ± 2.0
MCS3 ~ MCS7				11.0 ± 2.0	
W53		52~64	MCS0 ~ MCS2	13.0 ± 2.0	
			MCS3 ~ MCS7	11.0 ± 2.0	
W56		100~140	MCS0 ~ MCS2	13.0 ± 2.0	
			MCS3 ~ MCS7	11.0 ± 2.0	
W58		149~169	All Rates	4.0 ± 2.0	
IEEE 802.11n (HT40)		W52	38~46	MCS0 ~ MCS2	13.0 ± 2.0
	MCS3 ~ MCS7			11.0 ± 2.0	
	W53	54~62	MCS0 ~ MCS2	13.0 ± 2.0	
			MCS3 ~ MCS7	11.0 ± 2.0	
	W56	102~134	MCS0 ~ MCS2	13.0 ± 2.0	
			MCS3 ~ MCS7	11.0 ± 2.0	
	W58	151~167	All Rates	4.0 ± 2.0	
	IEEE 802.11ac (VHT20)	W52	36~48	VHT_SS1_MCS0 ~ VHT_SS1_MCS2	13.0 ± 2.0
VHT_SS1_MCS3 ~ VHT_SS1_MCS7				11.0 ± 2.0	
VHT_SS1_MCS8				10.0 ± 2.0	
W53		52~64	VHT_SS1_MCS0 ~ VHT_SS1_MCS2	13.0 ± 2.0	
			VHT_SS1_MCS3 ~ VHT_SS1_MCS7	11.0 ± 2.0	
			VHT_SS1_MCS8	10.0 ± 2.0	
W56		100~140	VHT_SS1_MCS0 ~ VHT_SS1_MCS2	13.0 ± 2.0	
			VHT_SS1_MCS3 ~ VHT_SS1_MCS7	11.0 ± 2.0	
			VHT_SS1_MCS8	10.0 ± 2.0	
W58		149~169	All Rates	4.0 ± 2.0	
IEEE 802.11ac (VHT40)		W52	38, 46	VHT_SS1_MCS0 ~ VHT_SS1_MCS2	13.0 ± 2.0
				VHT_SS1_MCS3 ~ VHT_SS1_MCS7	11.0 ± 2.0
	VHT_SS1_MCS8, VHT_SS1_MCS9			10.0 ± 2.0	
	W53	54, 62	VHT_SS1_MCS0 ~ VHT_SS1_MCS2	13.0 ± 2.0	

Mode	Band	Channel	Rate	Maximum Tune Up Tolerance [dBm]
	W56	102~134	VHT_SS1_MCS3 ~ VHT_SS1_MCS7	11.0 ± 2.0
			VHT_SS1_MCS8, VHT_SS1_MCS9	10.0 ± 2.0
			VHT_SS1_MCS0 ~ VHT_SS1_MCS2	13.0 ± 2.0
			VHT_SS1_MCS3 ~ VHT_SS1_MCS7	11.0 ± 2.0
			VHT_SS1_MCS8, VHT_SS1_MCS9	10.0 ± 2.0
	W58	151~167	All Rates	4.0 ± 2.0
IEEE 802.11ac (VHT80)	W52	42	VHT_SS1_MCS0 ~ VHT_SS1_MCS2	12.0 ± 2.0
			VHT_SS1_MCS3 ~ VHT_SS1_MCS7	11.0 ± 2.0
			VHT_SS1_MCS8, VHT_SS1_MCS9	10.0 ± 2.0
	W53	58	VHT_SS1_MCS0 ~ VHT_SS1_MCS2	12.0 ± 2.0
			VHT_SS1_MCS3 ~ VHT_SS1_MCS7	11.0 ± 2.0
			VHT_SS1_MCS8, VHT_SS1_MCS9	10.0 ± 2.0
	W56	106~138	VHT_SS1_MCS0 ~ VHT_SS1_MCS2	12.0 ± 2.0
			VHT_SS1_MCS3 ~ VHT_SS1_MCS7	11.0 ± 2.0
			VHT_SS1_MCS8, VHT_SS1_MCS9	10.0 ± 2.0
		W58	155	All Rates

## 15.4.2 Theory of Operation for Europe

**Table 70** shows the theory of operation tables for Europe for WLAN and Bluetooth.

**Table 70: Europe Theory of Operation for WLAN**

Frequency of Operation			Scan	Ad-hoc mode
2.4 GHz	11b/g/n (HT20)/ac (VHT20)	2412-2462 MHz	Active	Yes
W52	11a/n/ac ((V)HT20)	5180-5240 MHz	Active	Yes
	11n/ac ((V)HT40)	5190-5230 MHz	Active	Yes
	11ac (VHT80)	5210 MHz	Active	Yes
W53	11a/n/ac ((V)HT20)	5260-5320 MHz	Passive	No
	11n/ac ((V)HT40)	5270-5310 MHz	Passive	No
	11ac (VHT80)	5290 MHz	Passive	No
W56	11a/n/ac ((V)HT20)	5500-5700 MHz	Passive	No
	11n/ac ((V)HT40)	5510-5670 MHz	Passive	No
	11ac (VHT80)	5530-5610 MHz	Passive	No
W58	11a/n/ac ((V)HT20)	5745-5845 MHz	Active	Yes
	11n/ac ((V)HT40)	5755-5835 MHz	Active	Yes
	11ac (VHT80)	5775 MHz	Active	Yes



## 16 Tape and Reel Packing

This section provides the general specifications for tape and reel packing.

### 16.1 Dimensions of Tape (Plastic Tape)

The dimension of the tape is as follows:

- The corner and ridge radiuses (R) of inside cavity are 0.3 mm maximum.
- Cumulative tolerance of 10 pitches of the sprocket hole is  $\pm 0.15$  mm
- Measuring of cavity positioning is based on cavity center in accordance with JIS/IES standard.

**Figure 19** is a graphical representation of the tape dimension (plastic tape).

**Figure 19: Dimensions of Tape (Plastic tape)**

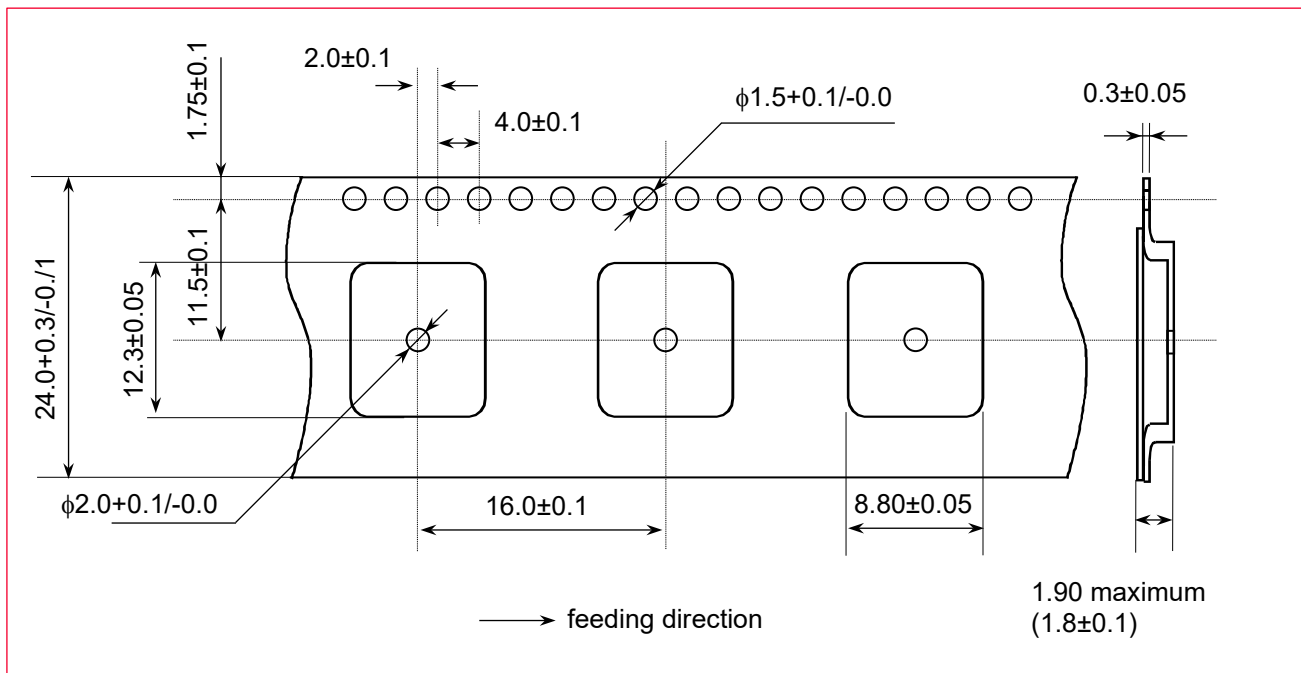

## 16.2 Dimensions of Reel

Figure 20 shows the reel dimensions.

Figure 20: Dimensions of Reel (Unit: mm)

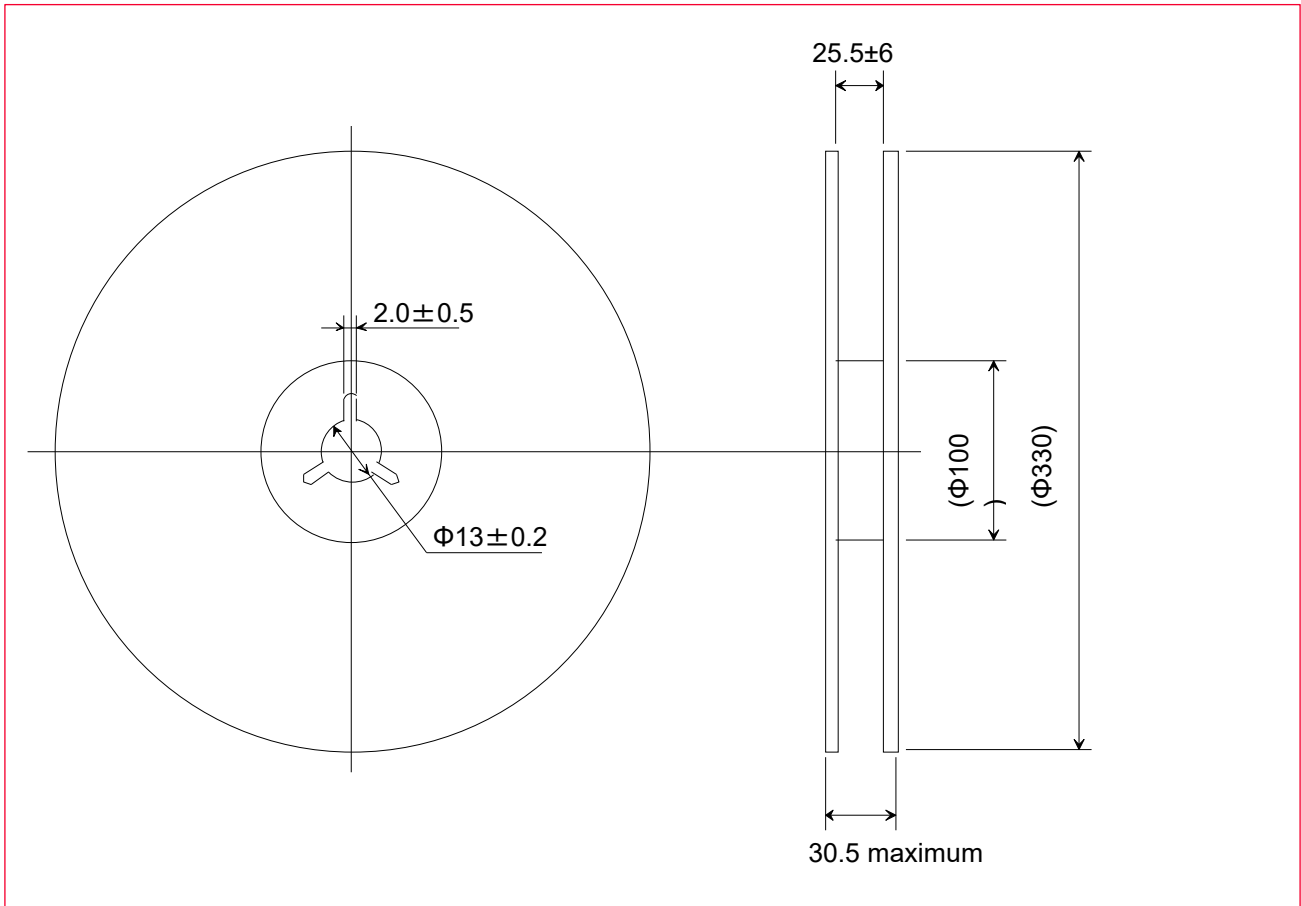

## 16.3 Taping Diagrams

Figure 21 shows the tapings diagrams.

Figure 21: Taping Diagrams

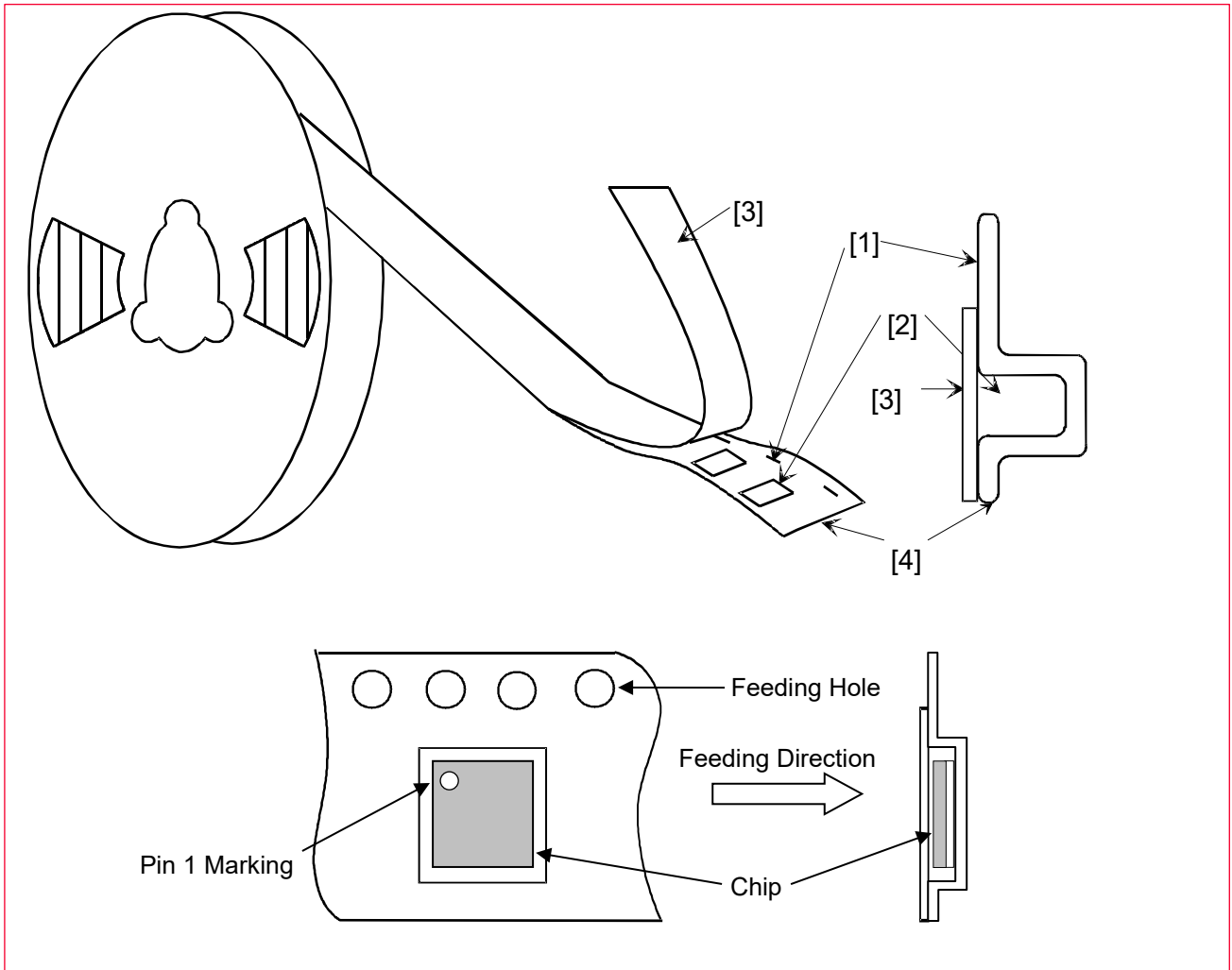

Table 71: Taping Specifications

Mark	Description
1	Feeding hole. As specified in <a href="#">Dimensions of Tape (Plastic tape)</a> ☒.
2	Hole for Chip. As specified in <a href="#">Dimensions of Tape (Plastic tape)</a> ☒.
3	Cover tape. 62 μm in thickness.
4	Base tape. As specified in <a href="#">Dimensions of Tape (Plastic tape)</a> ☒.

## 16.4 Leader and Tail Tape

The leader and tail tape are shown in **Figure 22**.

**Figure 22: Leader and Tail Tape**

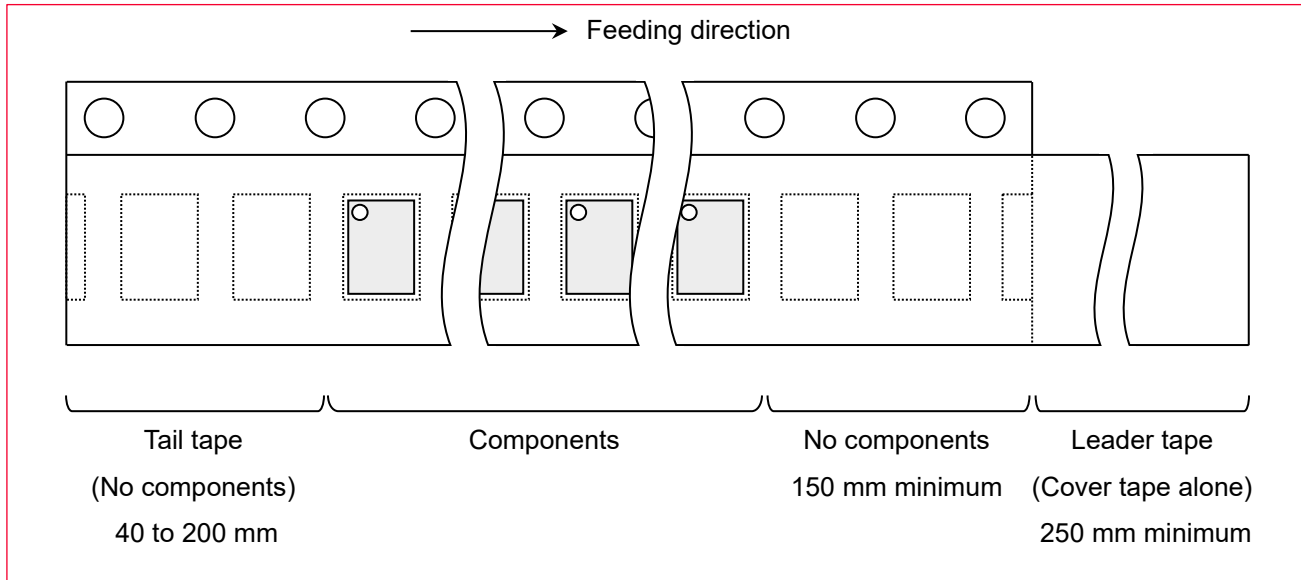

- The tape for chips is wound clockwise, the feeding holes to the right side as the tape is pulled toward the user.
- The cover tape and base tape are not adhered at no components area for 250 mm minimum
- Tear off strength against pulling of cover tape: 5 N minimum
- Packaging unit: 1000 pcs. / Reel
- Tape material:
  - Base tape: Plastic
  - Reel: Plastic
  - Cover tape, cavity tape and reel are made the anti-static processing.
- Peeling off force: 1.1 N maximum in the direction of peeling as shown in **Figure 23**.

**Figure 23: Peeling Force**

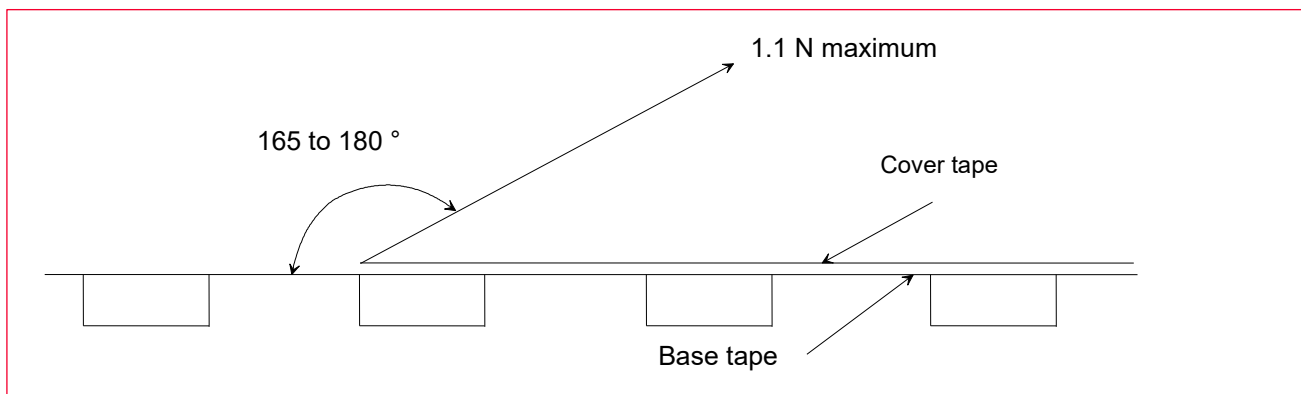

## 16.5 Packaging (Humidity Proof Packing)

Figure 24 shows the humidity proof packaging.

Figure 24: Humidity Proof Packaging

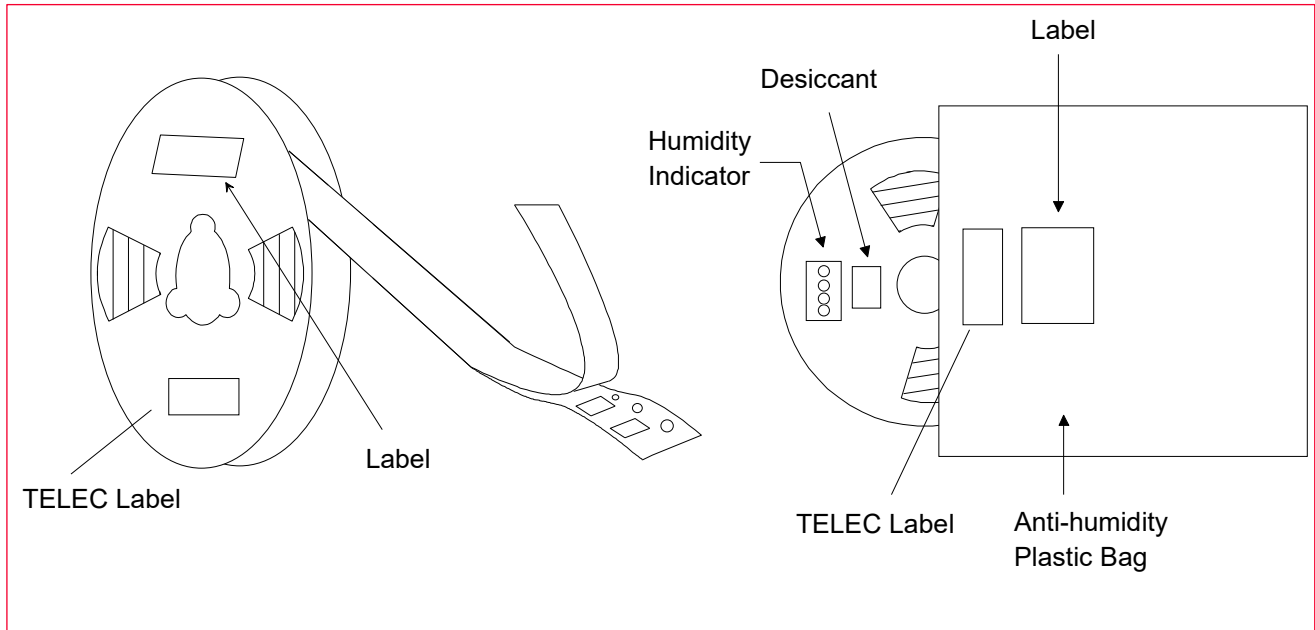

Tape and reel must be sealed with the anti-humidity plastic bag. The bag contains the desiccant and the humidity indicator.

## 17 Notice

### 17.1 Storage Conditions

- Please use this product within 6 months after receipt.
- The product shall be stored without opening the packing under the ambient temperature from 5 to 35 °C and humidity from 20 ~ 70 %RH (Packing materials may be deformed at the temperature over 40 °C).
- The product left more than 6 months after reception; it needs to be confirmed the solderability before used.
- The product *must* be stored in noncorrosive gas (Cl<sub>2</sub>, NH<sub>3</sub>, SO<sub>2</sub>, NO<sub>x</sub>, etc.).
- Any excess mechanical shock including, but not limited to, sticking the packing materials by sharp object and dropping the product, *must* not be applied in order not to damage the packing materials.
- This product is applicable to MSL3 (Based on JEDEC Standard J-STD-020)
  - After the packing opened, the product *must* be stored at ≤30 °C / <60 %RH and the product *should* be used within 168 hours after opening.
  - When the color of the indicator in the packing changed, the product shall be baked before soldering.
- Baking condition: 125 +5/-0 °C, 24 hours, 1 time
- The products must be baked on the heat-resistant tray because the material (Base Tape, Reel Tape and Cover Tape) is not heat-resistant.

### 17.2 Handling Conditions

- Be careful in handling or transporting products because excessive stress or mechanical shock may break products.
- Handle with care if products may have cracks or damages on their terminals. If there is any such damage, the characteristics of products may change. *Do not touch* products with bare hands that may result in poor solder ability and destroy by static electrical charge.

### 17.3 Standard PCB Design (Land Pattern and Dimensions)

- All the ground terminals should be connected to the ground patterns. Furthermore, the ground pattern should be provided between IN and OUT terminals. Please refer to the specifications for the standard land dimensions.
- The recommended land pattern and dimensions is as Murata's standard. The characteristics of products may vary depending on the pattern drawing method, grounding method, land dimensions, land forming method of the NC terminals and the PCB material and thickness. Therefore, be sure to verify the characteristics in the actual set. When using non-standard lands, contact Murata beforehand.

## 17.4 Notice for Chip Placer

When placing products on the PCB, products may be stressed and broken by uneven forces from a worn-out chucking locating claw or a suction nozzle. To prevent products from damages, be sure to follow the specifications for the maintenance of the chip placer being used. For the positioning of products on the PCB, be aware that mechanical chucking may damage products.

## 17.5 Soldering Conditions

The recommendation conditions of soldering are as in the following figure.

Soldering must be carried out by the above-mentioned conditions to prevent products from damage. Set up the highest temperature of reflow within 260 °C. Contact Murata before use if concerning other soldering conditions.

**Figure 25: Reflow soldering standard conditions (Example)**

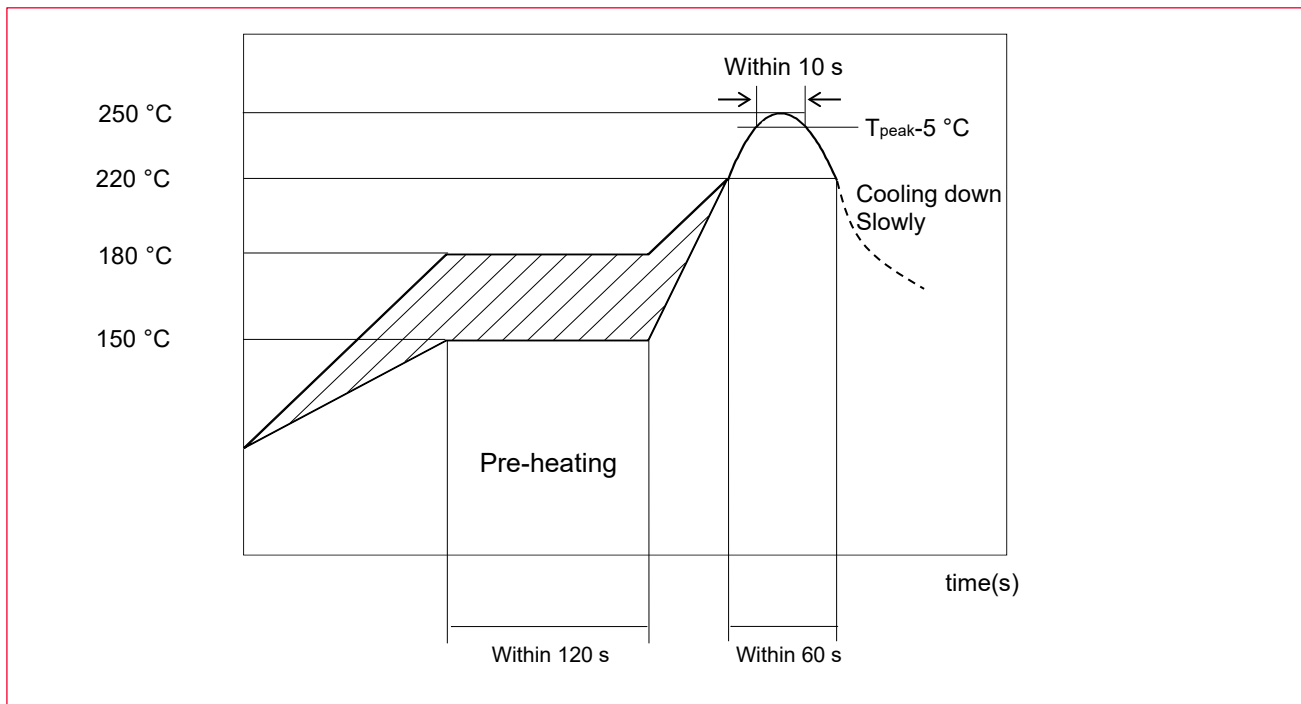

Please use the reflow within 2 times.

Use rosin type flux or weakly active flux with a chlorine content of 0.2 wt % or less.

## 17.6 Cleaning

Since this Product is Moisture Sensitive, any cleaning is not recommended. If any cleaning process is done the customer is responsible for any issues or failures caused by the cleaning process.

## 17.7 Operational Environment Conditions

Products are designed to work for electronic products under normal environmental conditions (ambient temperature, humidity, and pressure). Therefore, products have no problems to be used under the similar conditions to the above-mentioned. However, if products are used under the following circumstances, it may damage products and leakage of electricity and abnormal temperature may occur.

- In an atmosphere containing corrosive gas (Cl<sub>2</sub>, NH<sub>3</sub>, SO<sub>x</sub>, NO<sub>x</sub> etc.).
- In an atmosphere containing combustible and volatile gases.
- Dusty place.
- Direct sunlight place.
- Water splashing place.
- Humid place where water condenses.
- Freezing place.



If there are possibilities for products to be used under the preceding clause, consult with Murata before actual use.



Do not apply static electricity or excessive voltage while assembling and measuring, as it might be a cause of degradation or destruction to apply static electricity to products.

## 17.8 Input Power Capacity

Products shall be used in the input power capacity as specified in this specification.

Inform Murata beforehand, in case that the components are used beyond such input power capacity range.



## 18 Preconditions to Use Our Products



PLEASE READ THIS NOTICE BEFORE USING OUR PRODUCTS.

Please make sure that your product has been evaluated and confirmed from the aspect of the fitness for the specifications of our product when our product is mounted to your product.

All the items and parameters in this product specification/datasheet/catalog have been prescribed on the premise that our product is used for the purpose, under the condition and in the environment specified in this specification. You are requested not to use our product deviating from the condition and the environment specified in this specification.

Please note that the only warranty that we provide regarding the products is its conformance to the specifications provided herein. Accordingly, we shall not be responsible for any defects in products or equipment incorporating such products, which are caused under the conditions other than those specified in this specification.

WE HEREBY DISCLAIM ALL OTHER WARRANTIES REGARDING THE PRODUCTS, EXPRESS OR IMPLIED, INCLUDING WITHOUT LIMITATION ANY WARRANTY OF FITNESS FOR A PARTICULAR PURPOSE, THAT THEY ARE DEFECT-FREE, OR AGAINST INFRINGEMENT OF INTELLECTUAL PROPERTY RIGHTS.

You agree that you will use any and all software or program code (including but not limited to hcd, firmware, nvram, and blob) we may provide or to be embedded into our product ("Software") provided that you use the Software bundled with our product. YOU AGREE THAT THE SOFTWARE SHALL BE PROVIDED TO YOU "AS IS" BASIS, MURATA MAKES NO REPRESENTATIONS OR WARRANTIES THAT THE SOFTWARE IS ERROR-FREE OR WILL OPERATE WITHOUT INTERRUPTION. AND MORE, MURATA MAKES NO REPRESENTATIONS OR WARRANTIES OF ANY KIND WHETHER EXPRESS OR IMPLIED WITH RESPECT TO THE SOFTWARE. MURATA EXPRESSLY DISCLAIM ANY AND ALL WARRANTIES OR CONDITIONS OF MERCHANTABILITY, FITNESS FOR A PARTICULAR PURPOSE NOR THE WARRANTY OF TITLE OR NON-INFRINGEMENT OF INTELLECTUAL PROPERTY RIGHTS.

You shall indemnify and hold harmless us, our affiliates, and our licensor from and against any and all claims, costs, expenses and liabilities (including attorney's fees), which arise in connection with the using the Software.

The product shall not be used in any application listed below which requires especially high reliability for the prevention of such defect as may directly cause damage to the third party's life, body or property. You acknowledge and agree that, if you use our products in such applications, we will not be responsible for any failure to meet such requirements. Furthermore, YOU AGREE TO INDEMNIFY AND DEFEND US AND OUR AFFILIATES AGAINST ALL CLAIMS, DAMAGES, COSTS, AND EXPENSES THAT MAY BE INCURRED, INCLUDING WITHOUT LIMITATION, ATTORNEY FEES AND COSTS, DUE TO THE USE OF OUR PRODUCTS AND THE SOFTWARE IN SUCH APPLICATIONS.

- Aircraft equipment.
- Aerospace equipment.
- Undersea equipment.
- Power plant control equipment.
- Medical equipment.
- Traffic signal equipment.

- Burning / explosion control equipment.
- Disaster prevention / crime prevention equipment.
- Transportation equipment (vehicles, trains, ships, elevator, etc.).
- Application of similar complexity and/ or reliability requirements to the applications listed in the above.

We expressly prohibit you from analyzing, breaking, reverse-engineering, remodeling altering, and reproducing our product. Our product cannot be used for the product which is prohibited from being manufactured, used, and sold by the regulations and laws in the world.

We do not warrant or represent that any license, either express or implied, is granted under any our patent right, copyright, mask work right, or our other intellectual property right relating to any combination, machine, or process in which our products or services are used. Information provided by us regarding third-party products or services does not constitute a license from us to use such products or services or a warranty or endorsement thereof. Use of such information may require a license from a third party under the patents or other intellectual property of the third party, or a license from us under our patents or other intellectual property.

Please do not use our products, our technical information and other data provided by us for the purpose of developing of mass-destruction weapons and the purpose of military use.

Moreover, you must comply with "foreign exchange and foreign trade law", the "U.S. export administration regulations", etc.

Please note that we may discontinue the manufacture of our products, due to reasons such as end of supply of materials and/or components from our suppliers.

By signing on specification sheet or approval sheet, you acknowledge that you are the legal representative for your company and that you understand and accept the validity of the contents herein. When you are not able to return the signed version of specification sheet or approval sheet within 30 days from receiving date of specification sheet or approval sheet, it shall be deemed to be your consent on the content of specification sheet or approval sheet. Customer acknowledges that engineering samples may deviate from specifications and may contain defects due to their development status. We reject any liability or product warranty for engineering samples. In particular we disclaim liability for damages caused by

- The use of the engineering sample other than for evaluation purposes, particularly the installation or integration in the product to be sold by you,
- Deviation or lapse in function of engineering sample,
- Improper use of engineering samples.

We disclaim any liability for consequential and incidental damages.

If you can't agree with the above contents, please contact sales.

## Revision History

Revision Code	Date	Changed Item	Comment
	2020.01.15	First version	
A	2020.02.17	8. DIMENSIONS, MARKING AND TERMINAL CONFIGURATIONS 10. REFERENCE PERIPHERAL CIRCUIT	<ul style="list-style-type: none"> <li>Added label design information.</li> <li>Added Reference Circuit</li> </ul>
B	2020.06.15	TOP page 7. Module Pin Descriptions  11. Pin States	<ul style="list-style-type: none"> <li>Changed part number to LBEE5XV1YM</li> <li>Changed pin name RXP/RXN/TXP/TXN to - PCIE_RXP/PCIE_RXN/PCIE_TXP/PCIE_TXN.</li> <li>Added pin state table</li> </ul>
C	2020.06.20	4. Dimensions	<ul style="list-style-type: none"> <li>Added Solder bump and defined T1 dimension</li> </ul>
D	2020.08.07	9.10 DC/RF Characteristics for Bluetooth 9.11 DC/RF Characteristics for Bluetooth (LE)	<ul style="list-style-type: none"> <li>Defined output power</li> <li>Defined output power</li> </ul>
E	2020.11.06	Updated to new format 1. Scope 2. Key Features 5. Certification Information 6. Dimensions, Marking and Terminal configurations 9. Operating Conditions 12. DC/RF Characteristics 15. Tape and Reel Packing APPENDIX	<ul style="list-style-type: none"> <li>Changed Bluetooth version 5.1 to 5.2</li> <li>Changed Bluetooth version 5.1 to 5.2</li> <li>Added certification information</li> <li>Updated marking to final</li> <li>Added peak current.</li> <li>Fixed TBD specifications</li> <li>Added packing information.</li> <li>Added User manual and Antenna Installation Guide</li> </ul>
F	2020.12.01	11.4 High speed UART specifications	<ul style="list-style-type: none"> <li>Added.</li> </ul>
G	2021.01.07	7.1 Pin Descriptions 7.2. Pin Descriptions  APPENDIX	<ul style="list-style-type: none"> <li>Corrected Typo (Pin64)</li> <li>Added description for PCM and UART related pins.</li> <li>Added configuration manual</li> </ul>
H	2020.01.26	TOP page, 3. Ordering Information 9.1 Operating Conditions	<ul style="list-style-type: none"> <li>Changed tentative P/N</li> <li>Updated VIO_SD</li> </ul>
I	2021.3.04	11.4 High speed UART specifications 2. Features 7.3. Configuration pins Added default baud rate information.	<ul style="list-style-type: none"> <li>Added default baud rate information</li> <li>Added comment on USB IF</li> <li>Added comment on USB IF</li> </ul>
J	2021.4.01	2. Key feature & 5.2 Bluetooth Qualification 7.2 Pin Descriptions 9.1. Operating Conditions 14. Reference circuit	<ul style="list-style-type: none"> <li>Added a comment on supported Bluetooth functions</li> <li>Updated the description of PMIC_EN</li> <li>Added VIO_SD 1.8V mode</li> <li>Added values of matching components</li> </ul>
K	2021.04.26	7.2 Pin descriptions 7.3 Configuration pins 7.4 Pin States - Added comment to AVDD18 pin	<ul style="list-style-type: none"> <li>Added comment to AVDD18 pin</li> <li>Added comment on pull-up</li> <li>Changed DVDD18 to AVDD18 Added Internal pull values</li> </ul>
L	2021.12.14	7.4 Pin States	<ul style="list-style-type: none"> <li>Added SLP_CLK_IN</li> </ul>

Revision Code	Date	Changed Item	Comment
		9.1 Operating Conditions 9.2 External Sleep Clock Requirements 10. Power Sequence 14. Reference Peripheral Circuit - Added SLP_CLK_IN	<ul style="list-style-type: none"> <li>Defined IO current and Peak current</li> <li>Added a comment</li> <li>Defined timing parameters</li> <li>Corrected locations of DC blocker for PCIE signal.</li> </ul>
M	2022.04.08	9.1 Operating Conditions 9.4. Package Thermal Conditions 12.10. DC/RF Characteristics for Bluetooth 12.11. DC/RF Characteristics for Bluetooth	<ul style="list-style-type: none"> <li>Defined Ta and Tj.</li> <li>Added.</li> <li>Added test method</li> <li>Added test method</li> </ul>
N	2022.06.09	Appendix	<ul style="list-style-type: none"> <li>Translated Japanese to English</li> </ul>
O	2022.07.15	Appendix	<ul style="list-style-type: none"> <li>Power table on Japanese regulatory</li> </ul>
P	2022.09.27	2. Key Features	<ul style="list-style-type: none"> <li>Add Total Fit Value</li> </ul>
Q	2022.10.25	Appendix	<ul style="list-style-type: none"> <li>Add EU certification Information</li> </ul>
R	2022.10.31	2. Key Features 3. Ordering Information  7.4 Pin States 10. Power-Up / Power-Down Sequence 14. Reference Circuit Appendix	<ul style="list-style-type: none"> <li>Updated information</li> <li>Added Embedded Artists' M.2 module information.</li> <li>Added comments on termination of open pins.</li> <li>Renamed section</li> <li>Moved section to HW app note.</li> <li>Moved Appendix information into Sections 14 and 15.</li> <li>Moved antenna sections to HW app note.</li> <li>Added power table for Europe region.</li> </ul> <p>Updated to new format</p>



Copyright © Murata Manufacturing Co., Ltd. All rights reserved. The information and content in this document are provided “as-is” with no warranties of any kind and are for informational purpose only. Data and information have been carefully checked and are believed to be accurate; however, no liability or responsibility for any errors, omissions, or inaccuracies is assumed.

Wi-Fi® is a registered trademark of Wi-Fi Alliance. The Bluetooth® word mark and logos are registered trademarks owned by Bluetooth SIG, Inc. Other brand and product names are trademarks or registered trademarks of their respective owners.

Specifications are subject to change without notice.

## X-ON Electronics

Largest Supplier of Electrical and Electronic Components

*Click to view similar products for [Multiprotocol Modules](#) category:*

*Click to view products by [Murata](#) manufacturer:*

Other Similar products are found below :

[9260.NGWG.NV](#) [958867](#) [AX210.NGWG.NV](#) [BM833](#) [ESP32-C3-MINI-1U-H4](#) [ESP32-WROOM-32U-16MB](#) [ESP32-WROOM-32UE](#)  
[ESP32-WROOM-32UE-H4](#) [ESP32-WROVER-IE-N16R8](#) [ESP32-WROOM-32E-H4](#) [ESP32-WROVER-E-N8R8](#) [ESP32-MINI-1-H4](#) [ESP32-](#)  
[WROOM-32U-H4](#) [ESP32-PICO-MINI-02-N8R2](#) [ESP32-PICO-MINI-02U-N8R2](#) [LBEE5XV1YM-574](#) [CC2651R3SIPAT0MOUR](#) [ESP32-C6-](#)  
[MINI-1-N4](#) [ESP32-C6-WROOM-1-N4](#) [ESP32-C6-WROOM-1U-N4](#) [ESP32-C6-WROOM-1-N8](#) [ESP32-H2-MINI-1-N2](#) [BE200.NGWG.NV](#)  
[BE200.NGWG](#) [BE202.NGWG.NV](#) [BE200.NGWG.NVX](#) [AX210.NGWG](#) [9260.NGWGII.NVK](#) [MAYA-W166-01B](#) [AX411.NGWG](#)  
[BG95M3LA-64-SGNS](#) [AX411.NGWG.NV](#) [AX210.D2WG](#) [AX210.NGWG.NVX](#) [AX211.NGWG](#) [9560.NGWG.NV](#) [9260.NGWGIE](#)  
[9260.NGWG](#) [BG95M2LA-64-SGNS](#) [ISP4520-AS-RH](#) [BG951AGLAA-N06-TA0AA](#) [LN60G840F](#) [CLIX-9377](#) [BG95M3LA-MINIPCIE](#)  
[LBEE5XV1XA-540](#) [NORA-W301-00B](#) [NORA-W306-00B](#) [NORA-W366-00B](#) [NORA-W361-00B](#) [EC25AUXGA-128-SGNS](#)  
[BG600LM3AA-D08-SGNSA](#)