



Messrs.:

Specification No. JEMFGL-1161

MANTECH TECHNOLOGY CO.,LTD.

Product Specification

Issued Date: July. 22. 2014

Part Description: CHIP MULTILAYER LC FILTER

Customer Part No.: _____

MURATA Part No.: LFL212G14TCWD820

<p>Acknowledgement of reception</p> <p>We have received the attached specification</p> <p>Date: _____</p> <p>Company: _____</p> <p>Dept.: _____</p>	
<p>Representative</p> <p>_____</p> <p>(Signature) (Type)</p>	<p>Received by</p> <p>_____</p> <p>(Signature) (Type)</p>

Sales office

(Signature)
(Type)

(Company name/Dept.)

Technical Dept.

Prepared by

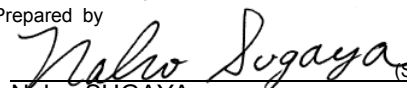
Naho SUGAYA (Signature)
(Type)

Representative



Muneyoshi Yamamoto (Signature)
(Type)

Manager
Product Engineering Section II
Multilayer Products Dept.
Communication System Division
MURATA MFG. CO., LTD.

(Company name/Dept.)

INDEX

1. Part Number	... p2
2. Operating Temperature Range	... p2
3. RoHS Compliance	... p2
4. Construction, Dimensions, Marking and Terminal Configurations	... p3
5. Electrical Characteristics	... p4
6. Other Specification And Methods	... p5
7. Tape and Reel Packing	... p9

 Please be aware that an important notice concerning availability, standard warranty, and use in critical applications of Murata products and disclaimers thereto appears at the end of this specification sheet.

1. Part Number

LFL212G14TCWD820

2. Operating Temperature Range

-40 °C ~ +85 °C

3. RoHS compliance

This component can meet with RoHS compliance.

4. Construction, Dimensions, Marking and Terminal Configurations

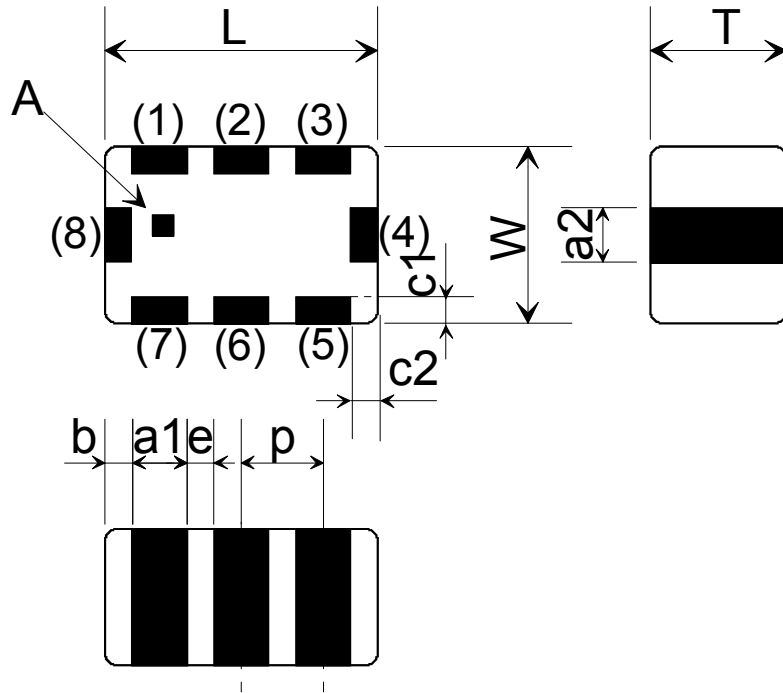

(in mm)

Mark	Meaning
A	Directional Input Mark

Mark	Dimensions	Mark	Dimensions
L	2.00 ± 0.15	b	0.20 ± 0.15
W	1.25 ± 0.10	c1	$0.3+0.1/-0.2$
T	1.05 max.	c2	$0.3+0.1/-0.2$
a1	$0.30+0.10/-0.15$	e	0.35 ± 0.10
a2	$0.30+0.10/-0.15$	p	0.65 ± 0.05

(TERMINAL CONFIGURATION)

Terminal No.	Terminal Name	Terminal No.	Terminal Name
(1)	GND	(5)	GND
(2)	NC	(6)	NC
(3)	GND	(7)	GND
(4)	OUT	(8)	IN

Terminal of "NC" should be fixed to the no connected pattern.

5. Electrical Characteristics (-40°C ~ +85°C)

Nominal Characteristics Impedance	50 Ω
Nominal Center Frequency	1940.00 MHz
Pass Band Range (BW)	fo ± 230.00 MHz
Insertion Loss in BW	1.00 dB max. at 25 °C 1.10 dB max. at -40 ~ +85 °C
Attenuation (Absolute value)	9.0 dB min. at 2400.00~2500.00 MHz 20.0 dB min. at 3250.00~3350.00 MHz 18.0 dB min. at 3420.00~3570.00 MHz 16.0 dB min. at 3700.00~3820.00 MHz 16.0 dB min. at 3840.00~3960.00 MHz 15.0 dB min. at 4100.00~4600.00 MHz 15.0 dB min. at 4905.00~5845.00 MHz 18.0 dB min. at 5850.00~6400.00 MHz 2.0 dB min. at 6600.00~7350.00 MHz
V.S.W.R. in BW	2.0 max.
Power Capacity	3 W max.

NOTE : The above-mentioned values have been obtained according to our own measuring methods(testing jig : Fig.1,Zo=50Ω) and may vary depending on the circuit, in which this component is actually incorporated.

You are, therefore, kindly requested to test the performance of this component incorporating in your set.

6. OTHER SPECIFICATION AND METHODS

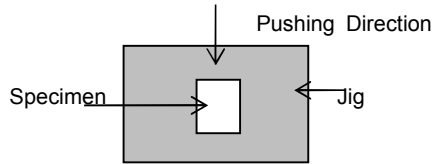
No.	Items	Specifications	Test Methods
1	Vibration Resistance	Appearance	No severe damages
		Electrical Specifications	Satisfy specifications listed in paragraph 5 over operational temperature range
2	Shock	Appearance	No severe damages
		Electrical Specifications	Satisfy specifications listed in paragraph 5 over operational temperature range
3	Deflection	No damage with 2mm deflection	Solder specimens on the testing jig (glass epoxy boards) shown in appended Fig.3 by a solder. The soldering shall be done either by iron or reflow and be conducted with care so that the soldering is uniform and free of defect such as by heat shock.
4	Soldering strength (Push Strength)	9.8 N Minimum	<p>Solder specimens onto test jig shown below. Apply pushing force at 0.5mm/s until electrode pads are peeled off or ceramics are broken. Pushing force is applied to longitudinal direction.</p> 
5	Solderability of Termination	75% of the terminations is to be soldered evenly and continuously.	<p>Immerse specimens first a ethanol (JIS-K-8101) solution of rosin (JIS-K-5902) (25% rosin in weight proportion), then in a solder solution for 2±0.5 s at 230±5 °C.</p> <p>Preheat : 100 ~ 120 °C、60 s</p> <p>Solder Paste : Sn-Ag-Cu</p> <p>Flux : Solution of ethanol and rosin (25 % rosin in weight proportion)</p>

6	Resistance to Soldering Heat (Dipping)	Appearance	No severe damages	Immerse the chip in the solder solution of 270±5 °C for 20±0.5 s (flow soldering bath) after preheating for 1 min at 120 to 150 °C. Then set it for 2 to 24 h at room temperature and measure.									
		Electrical specifications	Satisfy specifications listed in paragraph 5 over operational temperature range										
7	Resistance to Soldering Heat (Reflow)	Appearance	No severe damages	Preheat Temperature : 150±10 °C Preheat Period : 60 s. min. Peak Temperature : 255±5 °C Peak Temp. Period : 10 s. Specimens are soldered twice with the above condition, then kept in room condition for 24 h before measurements.									
		Electrical specifications	Satisfy specifications listed in paragraph 5 over operational temperature range										
8	High Temp. Exposure	Appearance	No severe damages	Temperature : 85±2 °C Period : 1000+48/-0 h Room Condition : 2 ~ 24 h									
		Electrical specifications	Satisfy specifications listed in paragraph 5 over operational temperature range										
9	Temperature Cycle	Appearance	No severe damages	Set the specimens to the supporting jig in the same manner and under the same conditions as Fig.1 and conduct the 100. cycles according to the temperatures and time shown in the following table. Set it for 2 to 24 h at room temperature, then measure.									
		Electrical specifications	Satisfy specifications listed in paragraph 5 over operational temperature range										
<table border="1" style="margin-left: auto; margin-right: auto;"> <thead> <tr> <th>Step</th> <th>1</th> <th>2</th> </tr> </thead> <tbody> <tr> <td>Temp.(°C)</td> <td>Min. Operating Temp.+0/-3</td> <td>Max. Operating Temp.+3/-0</td> </tr> <tr> <td>Time(min)</td> <td>30±3</td> <td>30±3</td> </tr> </tbody> </table>					Step	1	2	Temp.(°C)	Min. Operating Temp.+0/-3	Max. Operating Temp.+3/-0	Time(min)	30±3	30±3
Step	1	2											
Temp.(°C)	Min. Operating Temp.+0/-3	Max. Operating Temp.+3/-0											
Time(min)	30±3	30±3											
10	Humidity (Steady State)	Appearance	No severe damages	Temperature : 85±2 °C Humidity : 85±5 %RH Period : 1000+48/-0 h Room Condition : 2 ~ 24 h									
		Electrical specifications	Satisfy specifications listed in paragraph 5 over operational temperature range										

Excessive mechanical force or thermal stress may damage the products. Appropriate handling is required.

Fig.3; Testing Board

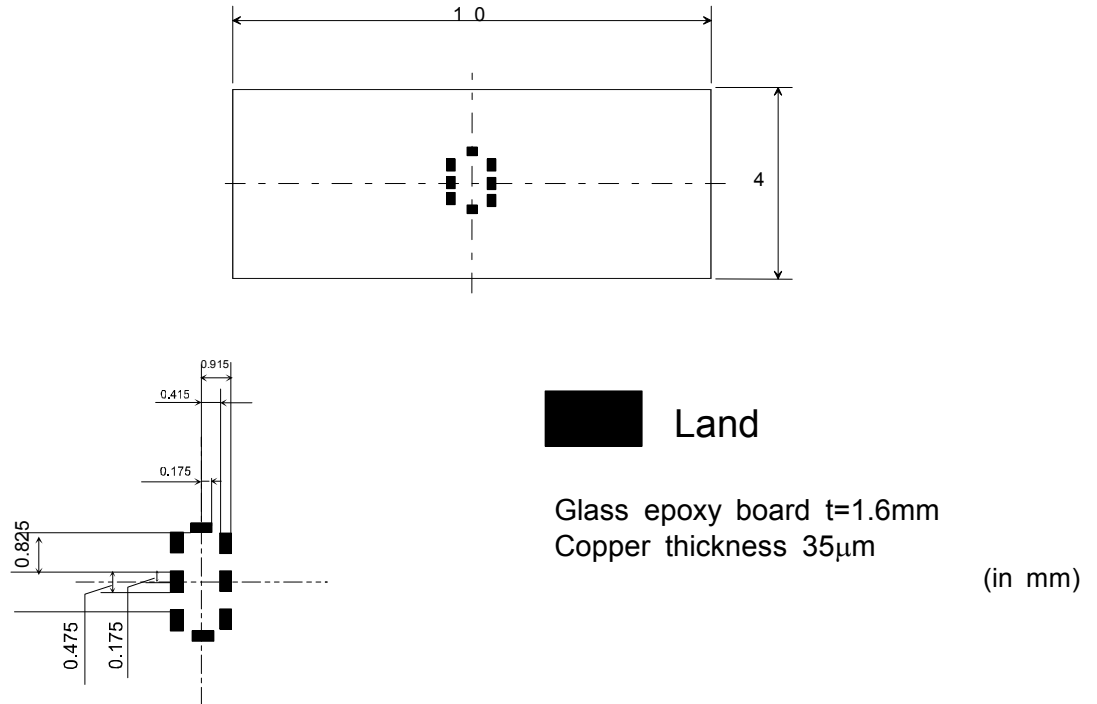

Mounted Situation

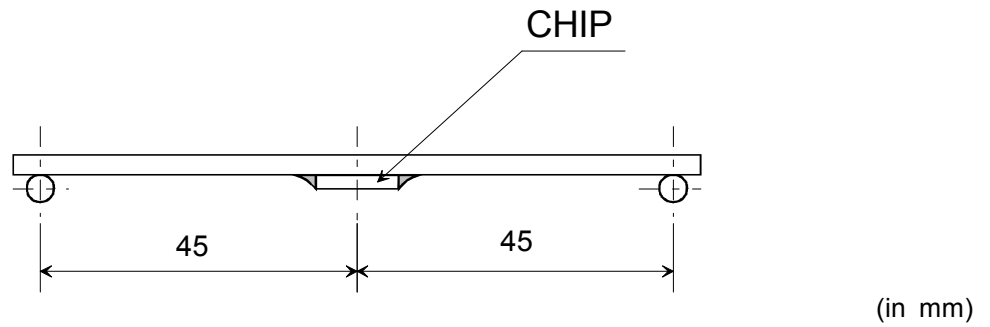

Testing Method

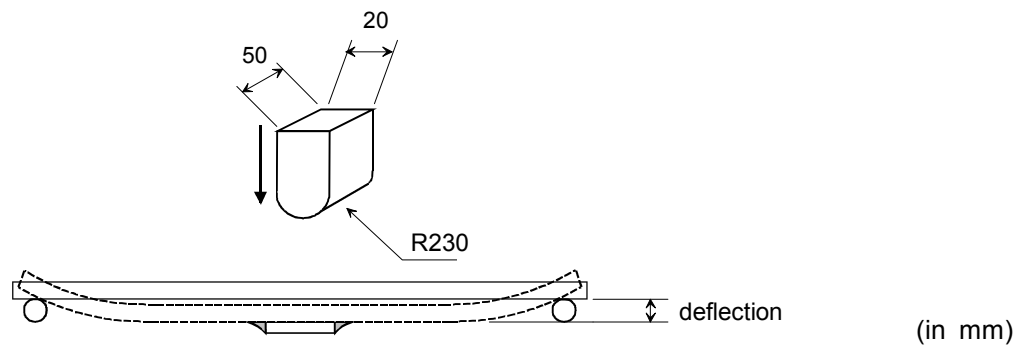

7. Tape and Reel Packing

(1) Dimensions of Tape (Plastic tape)

* Cumulative tolerance of max. ± 0.3 every 10 pitches

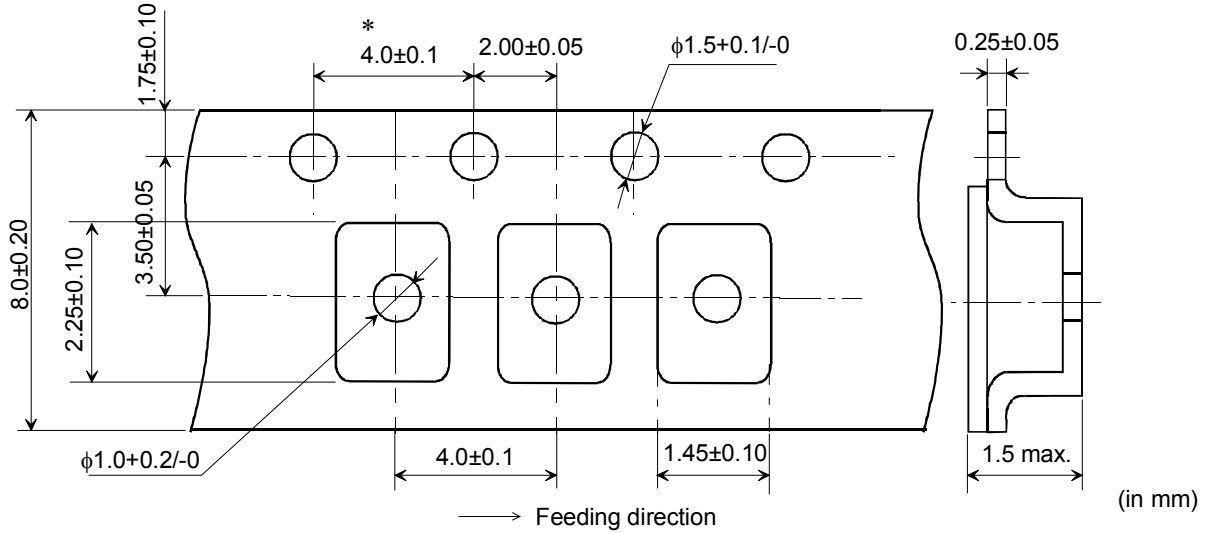

(2) Dimensions of Reel

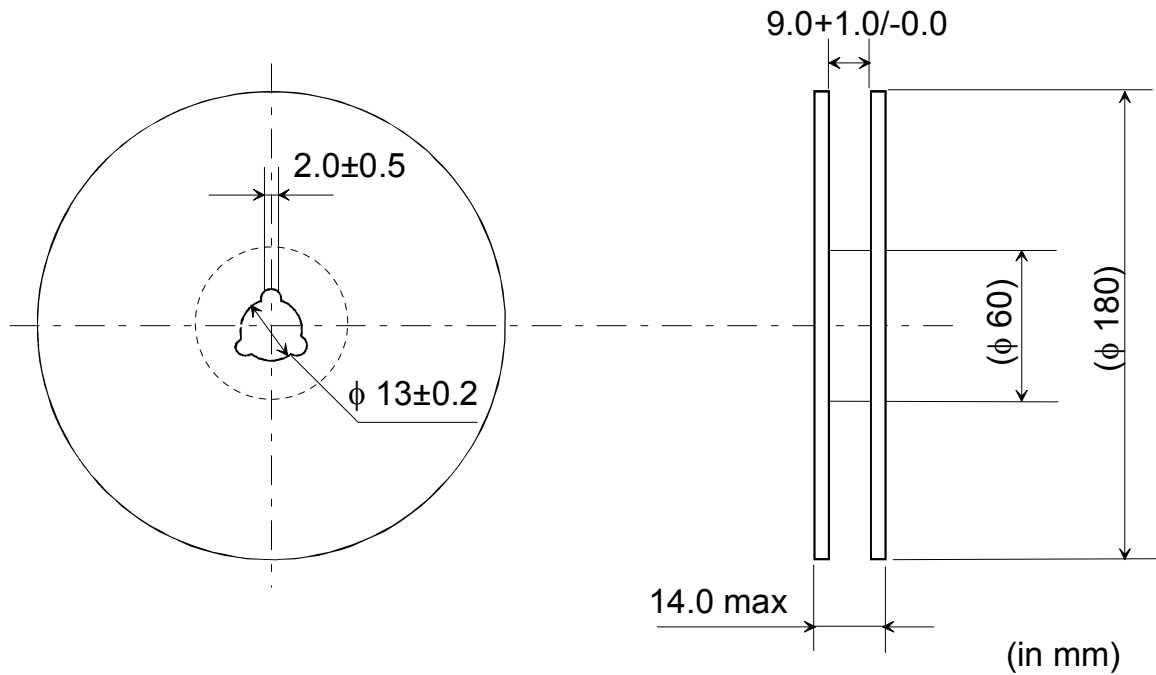

(3) Taping Diagrams

- [1] Feeding Hole : As specified in (1)
- [2] Hole for chip : As specified in (1)
- [3] Top tape : 62 μm in thickness
- [4] Base tape : As specified in (1)

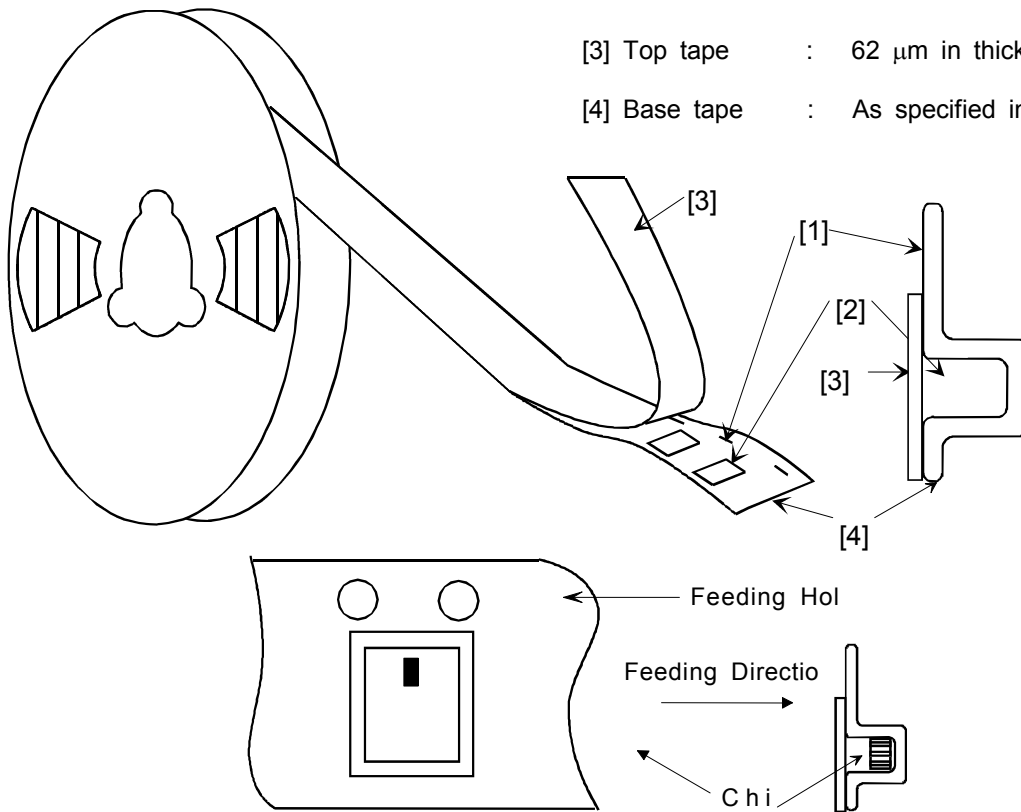

Package chips

(4) Leader and Tail tape

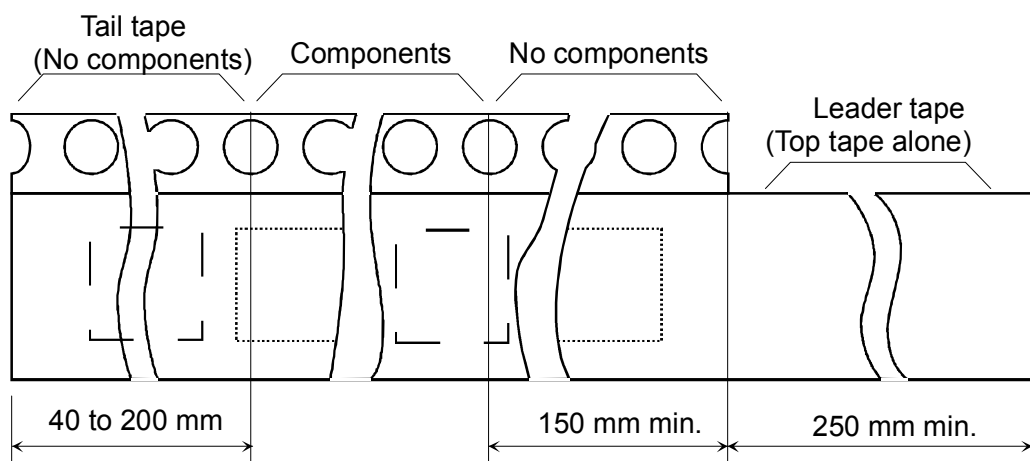

→ Feeding direction

- (5) The tape for chips are wound clockwise, the feeding holes to the right side as the tape is pulled toward the user.
- (6) The top tape and base tape are not adhered at no components area for 250 mm min.
- (7) Tear off strength against pulling of top tape : 5 N min.
- (8) Packaging unit : 4000 pcs. / reel
- (9) Material : Base tapePlastic
ReelPlastic
- (10) Peeling of force : in the direction of peeling as shown below.
Peeling speed : 300mm/min \pm 10mm/min

Tape width	Peeling of force (max)
8mm	1.0N
12-56mm	1.3N
72-200mm	1.5N

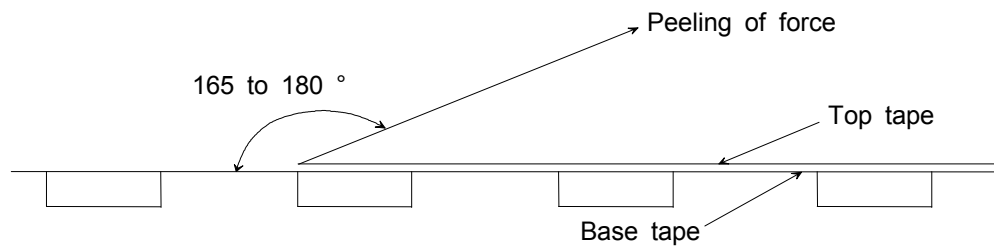

NOTICE

1. Storage Conditions

This product is applicable to MSL1 (Based on IPC/JEDEC J-STD-020)

To avoid damaging the solderability of the external electrodes, be sure to observe the following points.

- Store products where the ambient temperature is 15 to 35 °C and humidity 45 to 75% RH.
(Packing materials, In particular, may be deformed at the temperature over 40 °C.).
- Store products in non corrosive gas (Cl₂, NH₃, SO₂, Nox, etc.).
- Stored products should be used within 6 months of receipt. Solderability should be verified if this period is exceeded.

2. Handling Conditions :

Be careful in handling or transporting products because excessive stress or mechanical shock may break products.

Handle with care if products may have cracks or damages on their terminals, the characteristics of products may change. Do not touch products with bare hands that may result in poor solderability.

3. Standard PCB Design (Land Pattern and Dimensions) :

All the ground terminals should be connected to the ground patterns. Furthermore, the ground pattern should be provided between IN and OUT terminals. Please refer to the specifications for the standard land dimensions.

The recommended land pattern and dimensions is as Murata's standard. The characteristics of products may vary depending on the pattern drawing method, grounding method, land dimensions, land forming method of the NC terminals and the PCB material and thickness. Therefore, be sure to verify the characteristics in the actual set. When using non-standard lands, contact Murata beforehand.

4. Notice for Chip Placer :

When placing products on the PCB, products may be stressed and broken by uneven forces from a worn-out chucking locating claw or a suction nozzle. To prevent products from damages, be sure to follow the specifications for the maintenance of the chip placer being used. For the positioning of products on the PCB, be aware that mechanical chucking may damage products.

5. Soldering Conditions :

The recommendation conditions of soldering are as in the following figure.

When products are immersed in solvent after mounting, pay special attention to maintain the temperature difference within 100 °C. Soldering must be carried out by the above mentioned conditions to prevent products from damage. Set up the highest temperature of reflow within 260 °C.

Contact Murata before use if concerning other soldering conditions.

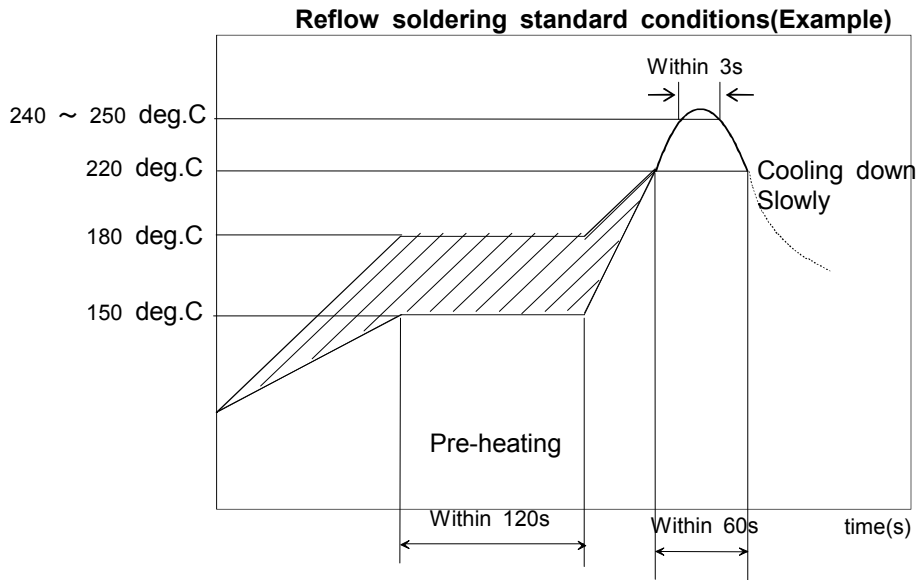

Please use the reflow within 2 times.

Use rosin type flux or weakly active flux with a chlorine content of 0.2 wt % or less.

6. Cleaning :

The total cleaning time of soaking, ultrasonic and steam methods should be within 5 minutes.

Consult with Murata concerning the cleaning solvent. In order to totally abolish ODC (Freon, Trichrolethan), Murata has carried out testing on non-cleaning and water cleaning (water- soluble flux, water-soluble cream solder, water-based cleaning solvent). Therefore, be sure to contact Murata beforehand for details when applying any of the above mentioned cleaning fluid.

The ultrasonic cleaning conditions are indicated below :

Cleaning solution	Pineapple alpha, Water
Frequency	50 - 60 kHz
Temperature	<40°C

If the ultrasonic output power is too high, the PCB may resonate and products mounted on the PCB may be damaged. The ultrasonic cleaning conditions may change depending on the size of the vessel and the size of the PCB. Contact Murata regarding conditions other than those stated above.

Be sure to completely dry up products immediately after cleaning.

7. Operational Environment Conditions :

Products are designed to work for electronic products under normal environmental conditions (ambient temperature, humidity and pressure). Therefore, products have no problems to be used under the similar conditions to the above-mentioned. However, if products are used under the following circumstances, it may damage products and leakage of electricity and abnormal temperature may occur.

- In an atmosphere containing corrosive gas (Cl₂, NH₃, SO_x, NO_x etc.).
- In an atmosphere containing combustible and volatile gases.
- Dusty place.
- Direct sunlight place.
- Water splashing place.
- Humid place where water condenses.
- Freezing place.

If there are possibilities for products to be used under the preceding clause, consult with Murata before actual use.

As it might be a cause of degradation or destruction to apply static electricity to products, do not apply static electricity or excessive voltage while assembling and measuring.

8. Input Power Capacity :

Products shall be used in the input power capacity as specified in this specifications.

Inform Murata beforehand, in case that the components are used beyond such input power capacity range.

**CAUTION**

PLEASE READ THIS NOTICE BEFORE USING OUR PRODUCTS.

Please make sure that your product has been evaluated and confirmed from the aspect of the fitness for the specifications of our product when our product is mounted to your product.

All the items and parameters in this product specification/datasheet/catalog have been prescribed on the premise that our product is used for the purpose, under the condition and in the environment specified in this specification. You are requested not to use our product deviating from the condition and the environment specified in this specification.

Please note that the only warranty that we provide regarding the products is its conformance to the specifications provided herein. Accordingly, we shall not be responsible for any defects in products or equipment incorporating such products, which are caused under the conditions other than those specified in this specification.

WE HEREBY DISCLAIMS ALL OTHER WARRANTIES REGARDING THE PRODUCTS, EXPRESS OR IMPLIED, INCLUDING WITHOUT LIMITATION ANY WARRANTY OF FITNESS FOR A PARTICULAR PURPOSE, THAT THEY ARE DEFECT-FREE, OR AGAINST INFRINGEMENT OF INTELLECTUAL PROPERTY RIGHTS.

The product shall not be used in any application listed below which requires especially high reliability for the prevention of such defect as may directly cause damage to the third party's life, body or property. You acknowledge and agree that, if you use our products in such applications, we will not be responsible for any failure to meet such requirements.

Furthermore, YOU AGREE TO INDEMNIFY AND DEFEND US AND OUR AFFILIATES AGAINST ALL CLAIMS, DAMAGES, COSTS, AND EXPENSES THAT MAY BE INCURRED, INCLUDING WITHOUT LIMITATION, ATTORNEY FEES AND COSTS, DUE TO THE USE OF OUR PRODUCTS IN SUCH APPLICATIONS.

- Aircraft equipment.
- Undersea equipment.
- Medical equipment.
- Traffic signal equipment.
- Burning / explosion control equipment
- Application of similar complexity and/ or reliability requirements to the applications listed in the above.
- Aerospace equipment
- Power plant control equipment
- Transportation equipment (vehicles, trains, ships, elevator, etc.).
- Disaster prevention / crime prevention equipment.

We expressly prohibit you from analyzing, breaking, Reverse-Engineering, remodeling altering, and reproducing our product. Our product cannot be used for the product which is prohibited from being manufactured, used, and sold by the regulations and laws in the world.

We do not warrant or represent that any license, either express or implied, is granted under any our patent right, copyright, mask work right, or our other intellectual property right relating to any combination, machine, or process in which our products or services are used. Information provided by us regarding third-party products or services does not constitute a license from us to use such products or services or a warranty or endorsement thereof. Use of such information may require a license from a third party under the patents or other intellectual property of the third party, or a license from us under our patents or other intellectual property.

Please do not use our products, our technical information and other data provided by us for the purpose of developing of mass-destruction weapons and the purpose of military use.

Moreover, you must comply with "foreign exchange and foreign trade law", the "U.S. export administration regulations", etc.

Please note that we may discontinue the manufacture of our products, due to reasons such as end of supply of materials and/or components from our suppliers.

Customer acknowledges that Murata will, if requested by you, conduct a failure analysis for defect or alleged defect of Products only at the level required for consumer grade Products, and thus such analysis may not always be available or be in accordance with your request (for example, in cases where the defect was caused by components in Products supplied to Murata from a third party).

By signing on specification sheet or approval sheet, you acknowledge that you are the legal representative for your company and that you understand and accept the validity of the contents herein.

When you are not able to return the signed version of specification sheet or approval sheet within 90 days from receiving date of specification sheet or approval sheet, it shall be deemed to be your consent on the content of specification sheet or approval sheet.

Customer acknowledges that engineering samples may deviate from specifications and may contain defects due to their development status.

We reject any liability or product warranty for engineering samples.

In particular we disclaim liability for damages caused by

- the use of the engineering sample other than for evaluation purposes, particularly the installation or integration in the product to be sold by you,
- deviation or lapse in function of engineering sample,
- improper use of engineering samples.

We disclaims any liability for consequential and incidental damages.

If you can't agree the above contents, you should inquire our sales.

X-ON Electronics

Largest Supplier of Electrical and Electronic Components

Click to view similar products for [Signal Conditioning](#) category:

Click to view products by [Murata](#) manufacturer:

Other Similar products are found below :

[MAPDCC0004](#) [PD0409J5050S2HF](#) [880157](#) [HHS-109-PIN](#) [DC1417J5005AHF](#) [DC4859J5005AHF](#) [AFS14A30-2185.00-T3](#) [AFS14A35-1591.50-T3](#) [DS-323-PIN](#) [DSS-313-PIN](#) [B39321R801H210](#) [B39321R821H210](#) [B39921B4317P810](#) [1A0220-3](#) [2089-6207-00](#) [JP510S](#) [LFB212G45SG8C341](#) [LFB322G45SN1A504](#) [LFL182G45TC3B746](#) [SF2159E](#) [30057](#) [1P510S](#) [CER0813B](#) [3A325](#) [40287](#) [41180](#) [ATB3225-75032NCT](#) [B69842N5807A150](#) [BD0810N50100AHF](#) [BD2326L50200AHF](#) [BD2425J50200AHF](#) [HMC189AMS8TR](#) [C5060J5003AHF](#) [JHS-114-PIN](#) [JP503AS](#) [DC0710J5005AHF](#) [DC2327J5005AHF](#) [DC3338J5005AHF](#) [43020](#) [LFB2H2G60BB1C106](#) [LFL15869MTC1B787](#) [X3C19F1-20S](#) [XC3500P-20S](#) [10013-20](#) [SF2081E](#) [SF2194E](#) [SF2238E](#) [CDBLB455KCAX39-B0](#) [RF1353C](#) [PD0922J5050D2HF](#)