

Reference Only

Spec No. JELF243C-0034G-01

P.1/12

CHIP COIL (CHIP INDUCTORS) LQP02HV□□□□02□ Reference Specification

1.Scope

This reference specification applies to LQP02HV□□□□02□ series, Chip coil (Chip Inductors).

2.Part Numbering

(ex) LQ P 02 H V 0N4 B 0 2 L
 Product ID Structure Dimension Applications and Characteristics Category Inductance Tolerance Features Electrode Packaging
 (L × W) and L:4mm-wide / plastic tape
 *B: Bulk

*Bulk packing also available. (A product is put in the plastic bag under the taping conditions.)

3.Rating

- Operating Temperature. -55°C to +125°C
- Storage Temperature. -55°C to +125°C

Customer Part Number	MURATA Part Number	Inductance		Q (min) (@500MHz)	DC Resistance (Ω max)	Self Resonant Frequency (GHz Min.)	Rated Current (mA)
		(nH) (@500MHz)	Tolerance				
	LQP02HV0N4B02L	0.4	B:±0.1nH	17	0.03	18.0	1000
	LQP02HV0N4C02L	0.4	C:±0.2nH	17	0.03	18.0	1000
	LQP02HV0N5B02L	0.5	B:±0.1nH	17	0.03	18.0	1000
	LQP02HV0N5C02L	0.5	C:±0.2nH	17	0.03	18.0	1000
	LQP02HV0N6B02L	0.6	B:±0.1nH	17	0.03	18.0	1000
	LQP02HV0N6C02L	0.6	C:±0.2nH	17	0.03	18.0	1000
	LQP02HV0N7B02L	0.7	B:±0.1nH	17	0.03	18.0	1000
	LQP02HV0N7C02L	0.7	C:±0.2nH	17	0.03	18.0	1000
	LQP02HV0N8B02L	0.8	B:±0.1nH	17	0.03	16.6	1000
	LQP02HV0N8C02L	0.8	C:±0.2nH	17	0.03	16.6	1000
	LQP02HV0N9B02L	0.9	B:±0.1nH	17	0.04	16.6	900
	LQP02HV0N9C02L	0.9	C:±0.2nH	17	0.04	16.6	900
	LQP02HV1N0B02L	1.0	B:±0.1nH	17	0.04	16.6	900
	LQP02HV1N0C02L	1.0	C:±0.2nH	17	0.04	16.6	900
	LQP02HV1N1B02L	1.1	B:±0.1nH	17	0.05	16.6	800
	LQP02HV1N1C02L	1.1	C:±0.2nH	17	0.05	16.6	800
	LQP02HV1N2B02L	1.2	B:±0.1nH	17	0.06	16.6	730
	LQP02HV1N2C02L	1.2	C:±0.2nH	17	0.06	16.6	730
	LQP02HV1N3B02L	1.3	B:±0.1nH	17	0.06	13.9	730
	LQP02HV1N3C02L	1.3	C:±0.2nH	17	0.06	13.9	730
	LQP02HV1N4B02L	1.4	B:±0.1nH	17	0.06	13.9	730
	LQP02HV1N4C02L	1.4	C:±0.2nH	17	0.06	13.9	730
	LQP02HV1N5B02L	1.5	B:±0.1nH	17	0.06	13.9	730
	LQP02HV1N5C02L	1.5	C:±0.2nH	17	0.06	13.9	730
	LQP02HV1N6B02L	1.6	B:±0.1nH	17	0.07	12.2	680
	LQP02HV1N6C02L	1.6	C:±0.2nH	17	0.07	12.2	680
	LQP02HV1N7B02L	1.7	B:±0.1nH	17	0.07	12.2	680
	LQP02HV1N7C02L	1.7	C:±0.2nH	17	0.07	12.2	680
	LQP02HV1N8B02L	1.8	B:±0.1nH	17	0.07	11.9	680
	LQP02HV1N8C02L	1.8	C:±0.2nH	17	0.07	11.9	680
	LQP02HV1N9B02L	1.9	B:±0.1nH	17	0.08	11.9	640
	LQP02HV1N9C02L	1.9	C:±0.2nH	17	0.08	11.9	640
	LQP02HV2N0B02L	2.0	B:±0.1nH	17	0.09	11.9	600
	LQP02HV2N0C02L	2.0	C:±0.2nH	17	0.09	11.9	600
	LQP02HV2N1B02L	2.1	B:±0.1nH	17	0.09	11.9	600
	LQP02HV2N1C02L	2.1	C:±0.2nH	17	0.09	11.9	600
	LQP02HV2N2B02L	2.2	B:±0.1nH	17	0.09	11.9	600
	LQP02HV2N2C02L	2.2	C:±0.2nH	17	0.09	11.9	600
	LQP02HV2N3B02L	2.3	B:±0.1nH	16	0.11	11.9	540
	LQP02HV2N3C02L	2.3	C:±0.2nH	16	0.11	11.9	540
	LQP02HV2N4B02L	2.4	B:±0.1nH	16	0.18	11.9	420
	LQP02HV2N4C02L	2.4	C:±0.2nH	16	0.18	11.9	420
	LQP02HV2N5B02L	2.5	B:±0.1nH	16	0.19	11.9	410
	LQP02HV2N5C02L	2.5	C:±0.2nH	16	0.19	11.9	410

Reference Only

Spec No. JELF243C-0034G-01

P.2/12

Customer Part Number	MURATA Part Number	Inductance		Q (min) (@500MHz)	DC Resistance (Ω max)	Self Resonant Frequency (GHz Min.)	Rated Current (mA)
		(nH) (@500MHz)	Tolerance				
	LQP02HV2N6B02L	2.6	B:±0.1nH	16	0.19	11.9	410
	LQP02HV2N6C02L	2.6	C:±0.2nH	16	0.19	11.9	410
	LQP02HV2N7B02L	2.7	B:±0.1nH	16	0.21	11.9	390
	LQP02HV2N7C02L	2.7	C:±0.2nH	16	0.21	11.9	390
	LQP02HV2N8B02L	2.8	B:±0.1nH	16	0.21	11.3	390
	LQP02HV2N8C02L	2.8	C:±0.2nH	16	0.21	11.3	390
	LQP02HV2N9B02L	2.9	B:±0.1nH	16	0.21	11.3	390
	LQP02HV2N9C02L	2.9	C:±0.2nH	16	0.21	11.3	390
	LQP02HV3N0B02L	3.0	B:±0.1nH	16	0.24	10.2	360
	LQP02HV3N0C02L	3.0	C:±0.2nH	16	0.24	10.2	360
	LQP02HV3N1B02L	3.1	B:±0.1nH	16	0.24	10.2	360
	LQP02HV3N1C02L	3.1	C:±0.2nH	16	0.24	10.2	360
	LQP02HV3N2B02L	3.2	B:±0.1nH	16	0.24	10.2	360
	LQP02HV3N2C02L	3.2	C:±0.2nH	16	0.24	10.2	360
	LQP02HV3N3B02L	3.3	B:±0.1nH	16	0.24	10.2	360
	LQP02HV3N3C02L	3.3	C:±0.2nH	16	0.24	10.2	360
	LQP02HV3N4B02L	3.4	B:±0.1nH	16	0.24	9.4	360
	LQP02HV3N4C02L	3.4	C:±0.2nH	16	0.24	9.4	360
	LQP02HV3N5B02L	3.5	B:±0.1nH	16	0.24	9.4	360
	LQP02HV3N5C02L	3.5	C:±0.2nH	16	0.24	9.4	360
	LQP02HV3N6B02L	3.6	B:±0.1nH	16	0.24	9.4	360
	LQP02HV3N6C02L	3.6	C:±0.2nH	16	0.24	9.4	360
	LQP02HV3N7B02L	3.7	B:±0.1nH	16	0.24	8.2	360
	LQP02HV3N7C02L	3.7	C:±0.2nH	16	0.24	8.2	360
	LQP02HV3N8B02L	3.8	B:±0.1nH	16	0.24	8.2	360
	LQP02HV3N8C02L	3.8	C:±0.2nH	16	0.24	8.2	360
	LQP02HV3N9B02L	3.9	B:±0.1nH	16	0.24	8.2	360
	LQP02HV3N9C02L	3.9	C:±0.2nH	16	0.24	8.2	360
	LQP02HV4N0B02L	4.0	B:±0.1nH	16	0.24	8.2	360
	LQP02HV4N0C02L	4.0	C:±0.2nH	16	0.24	8.2	360
	LQP02HV4N0B02E	4.0	B:±0.1nH	16	0.24	8.2	360
	LQP02HV4N0C02E	4.0	C:±0.2nH	16	0.24	8.2	360
	LQP02HV4N1B02L	4.1	B:±0.1nH	16	0.24	7.1	360
	LQP02HV4N1C02L	4.1	C:±0.2nH	16	0.24	7.1	360
	LQP02HV4N2B02L	4.2	B:±0.1nH	16	0.24	7.1	360
	LQP02HV4N2C02L	4.2	C:±0.2nH	16	0.24	7.1	360
	LQP02HV4N3H02L	4.3	H:±3%	16	0.24	7.1	360
	LQP02HV4N3J02L	4.3	J:±5%	16	0.24	7.1	360
	LQP02HV4N7H02L	4.7	H:±3%	16	0.24	7.1	360
	LQP02HV4N7J02L	4.7	J:±5%	16	0.24	7.1	360
	LQP02HV5N1H02L	5.1	H:±3%	16	0.25	7.1	360
	LQP02HV5N1J02L	5.1	J:±5%	16	0.25	7.1	360
	LQP02HV5N6H02L	5.6	H:±3%	16	0.46	7.1	260
	LQP02HV5N6J02L	5.6	J:±5%	16	0.46	7.1	260
	LQP02HV6N2H02L	6.2	H:±3%	16	0.46	7.1	260
	LQP02HV6N2J02L	6.2	J:±5%	16	0.46	7.1	260
	LQP02HV6N8H02L	6.8	H:±3%	16	0.46	7.1	260
	LQP02HV6N8J02L	6.8	J:±5%	16	0.46	7.1	260
	LQP02HV7N5H02L	7.5	H:±3%	16	0.53	7.1	240
	LQP02HV7N5J02L	7.5	J:±5%	16	0.53	7.1	240
	LQP02HV8N2H02L	8.2	H:±3%	16	0.57	7.1	230
	LQP02HV8N2J02L	8.2	J:±5%	16	0.57	7.1	230
	LQP02HV9N1H02L	9.1	H:±3%	16	0.57	5.5	230
	LQP02HV9N1J02L	9.1	J:±5%	16	0.57	5.5	230
	LQP02HV10NH02L	10	H:±3%	16	0.57	5.5	230
	LQP02HV10NJ02L	10	J:±5%	16	0.57	5.5	230
	LQP02HV11NH02L	11	H:±3%	16	0.65	5.5	220
	LQP02HV11NJ02L	11	J:±5%	16	0.65	5.5	220

Reference Only

Spec No. JELF243C-0034G-01

P.3/12

Customer Part Number	MURATA Part Number	Inductance		Q (min) (@500MHz)	DC Resistance (Ω max)	Self Resonant Frequency (GHz Min.)	Rated Current (mA)
		(nH) (@500MHz)	Tolerance				
	LQP02HV12NH02L	12	H:±3%	16	0.65	5.2	220
	LQP02HV12NJ02L	12	J:±5%	16	0.65	5.2	220
	LQP02HV13NH02L	13	H:±3%	16	0.75	5.0	200
	LQP02HV13NJ02L	13	J:±5%	16	0.75	5.0	200
	LQP02HV15NH02L	15	H:±3%	16	0.97	5.0	180
	LQP02HV15NJ02L	15	J:±5%	16	0.97	5.0	180
	LQP02HV16NH02L	16	H:±3%	16	1.08	4.8	170
	LQP02HV16NJ02L	16	J:±5%	16	1.08	4.8	170
	LQP02HV18NH02L	18	H:±3%	16	1.08	4.8	170
	LQP02HV18NJ02L	18	J:±5%	16	1.08	4.8	170
	LQP02HV20NH02L	20	H:±3%	16	1.48	4.5	140
	LQP02HV20NJ02L	20	J:±5%	16	1.48	4.5	140
	LQP02HV22NH02L	22	H:±3%	16	1.48	4.5	140
	LQP02HV22NJ02L	22	J:±5%	16	1.48	4.5	140
	LQP02HV24NH02L	24	H:±3%	16	2.00	3.2	120
	LQP02HV24NJ02L	24	J:±5%	16	2.00	3.2	120
	LQP02HV27NH02L	27	H:±3%	16	2.00	3.2	120
	LQP02HV27NJ02L	27	J:±5%	16	2.00	3.2	120

* Typical value is actual performance.

4. Testing Conditions

《Unless otherwise specified》

Temperature : Ordinary Temperature / 15°C to 35°C

Humidity : Ordinary Humidity / 25%(RH) to 85 %(RH)

《In case of doubt》

Temperature : 20°C ± 2°C

Humidity : 60%(RH) to 70 %(RH)

Atmospheric Pressure : 86kPa to 106 kPa

5. Appearance and Dimensions

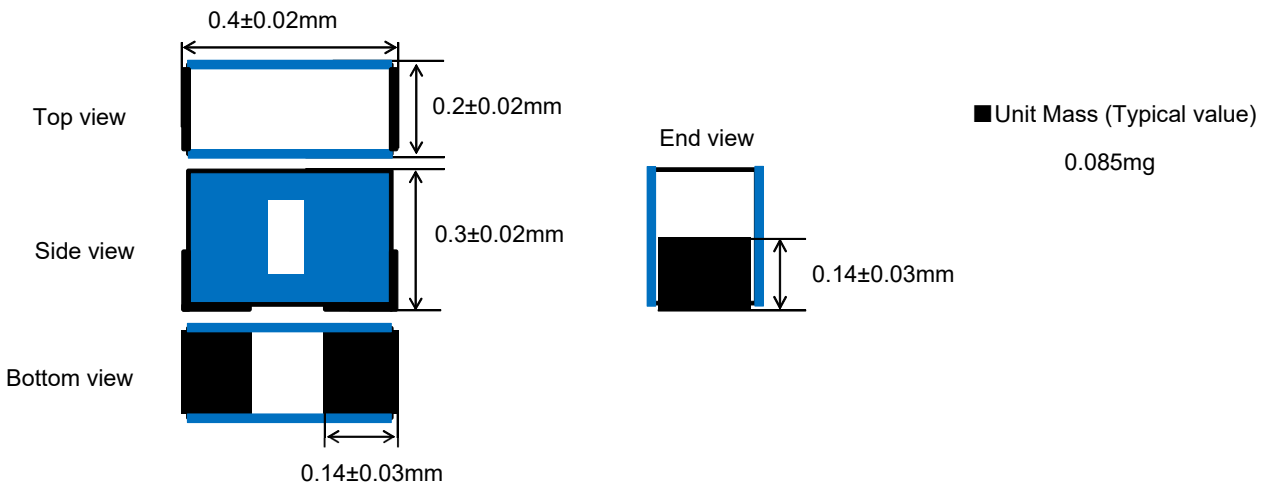

6. Marking

Side surface identification marking :Blue

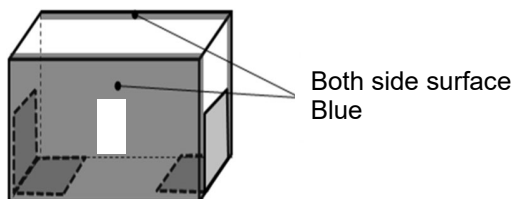

Reference Only

Spec No. JELF243C-0034G-01

P.4/12

7. Electrical Performance

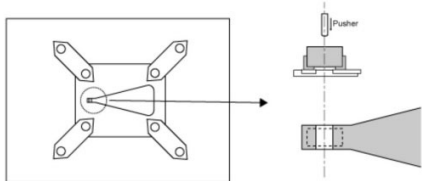
No.	Item	Specification	Test Method
7.1	Inductance	Inductance shall meet item 3.	<p>Measuring Equipment: KEYSIGHT E4991B or equivalent Measuring Frequency: 500MHz Measuring Fixture: KEYSIGHT 16198A Contact board: (KEYSIGHT :Guide PCA0201, 100 μm gap between electrode:60 μm)</p> <p>Measuring Condition: Test signal level / about 0dBm Electrical length /0mm Weight: about 250g</p> <p><Measuring example></p> 
7.2	Q	Q shall meet item 3.	<p>Measuring Method: See the endnote <Electrical Performance: Measuring Method of Inductance/Q></p>
7.3	DC Resistance	DC Resistance shall meet item 3.	Measuring Equipment: Digital multi meter
7.4	Self Resonant Frequency(S.R.F)	S.R.F shall meet item 3.	Measuring Equipment: KEYSIGHT N5230A or equivalent
7.5	Rated Current	Self temperature rise shall be limited to 25°C max.	The rated current is applied.

8. Mechanical Performance

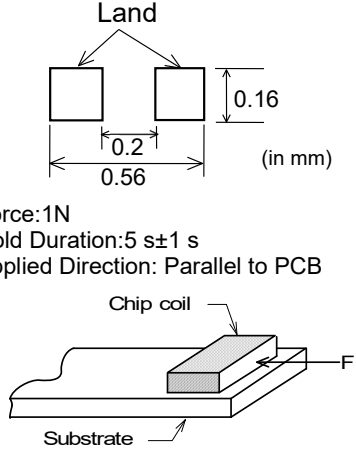
No.	Item	Specification	Test Method
8.1	Shear Test	Chip coil shall not be damaged after tested as test method.	<p>Substrate: Glass-epoxy substrate</p> <p style="text-align: center;">Land</p>  <p style="text-align: right;">(in mm)</p> <p>Force: 1N Hold Duration: 5 s \pm 1 s Applied Direction: Parallel to PCB</p>

Reference Only

Spec No. JELF243C-0034G-01

P.5/12

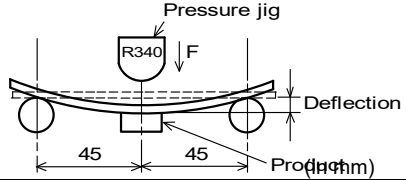
No.	Item	Specification	Test Method
8.2	Bending Test	Chip coil shall not be damaged after tested as test method.	Substrate: Glass-epoxy substrate (100mm × 40mm × 0.8mm) Speed of Applying Force: 1mm / s Deflection: 1mm Hold Duration: 30 s 
8.3	Vibration	Appearance: No damage	Substrate: Glass-epoxy substrate Oscillation Frequency: 10Hz to 2000Hz to 10Hz for 20 min Total amplitude 1.5 mm or Acceleration amplitude 196 m/s ² whichever is smaller. Testing Time: A period of 2h in each of 3 mutually perpendicular directions.
8.4	Solderability	The electrode shall be at least 90% covered with new solder coating.	Flux: Ethanol solution of rosin 25(wt)% (Immersed for 5s to 10s) Solder: Sn-3.0Ag-0.5Cu Pre-Heating: 150°C ± 10°C / 60s to 90s Solder Temperature: 240°C ± 5°C Immersion Time: 3s ± 1s
8.5	Resistance to Soldering Heat	Appearance: No damage Inductance Change: within ±10%	Flux: Ethanol solution of rosin 25(wt)% (Immersed for 5s to 10s) Solder: Sn-3.0Ag-0.5Cu Pre-Heating: 150°C ± 10°C / 60s to 90s Solder Temperature: 260°C ± 5°C Immersion Time: 5s ± 1s Then measured after exposure in the room condition for 24h ± 2h.

9. Environmental Performance

It shall be soldered on the substrate.

No.	Item	Specification	Test Method
9.1	Heat Resistance	Appearance: No damage Inductance Change: within ±10%	Substrate: Glass-epoxy substrate Temperature: 125°C ± 2°C Time: 1000h (+48h, -0h) Then measured after exposure in the room condition for 24h ± 2h.
9.2	Cold Resistance		Substrate: Glass-epoxy substrate Temperature: -55°C ± 3°C Time: 1000 h (+48h, -0h) Then measured after exposure in the room condition for 24h ± 2h.
9.3	Humidity		Substrate: Glass-epoxy substrate Temperature: 40°C ± 2°C Humidity: 90%(RH) to 95%(RH) Time: 1000 h (+48h, -0h) Then measured after exposure in the room condition for 24h ± 2h.
9.4	Temperature Cycle		Substrate: Glass-epoxy substrate 1 cycle: 1 step: -55°C ± 2°C / 30min ± 3 min 2 step: Ordinary temp. / 10~15 min 3 step: 125°C ± 2°C / 30 ± 3 min 4 step: Ordinary temp. / 10~15 min Total of 10 cycles Then measured after exposure in the room condition for 24h ± 2h.

Reference Only

10. Specification of Packaging

10.1 Appearance and Dimensions

【4mm-wide / plastic tape】

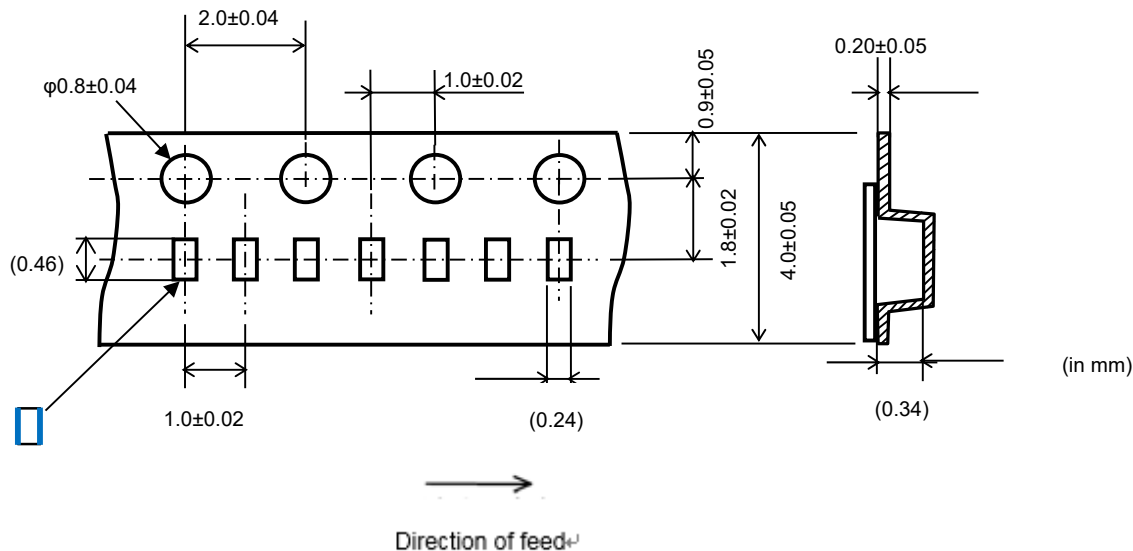

10.2 Specification of Taping

【4mm-wide / plastic tape】

- (1) Packing quantity (standard quantity)
30,000 pcs. / reel
- (2) Packing Method
Products shall be packed in the each embossed cavity of plastic tape and sealed by cover tape.
- (3) Sprocket hole
The sprocket holes are to the right as the tape is pulled toward the user.
- (4) Spliced point
Plastic tape and Cover tape has no spliced point.
- (5) Missing components number
Missing components number within 0.1 % of the number per reel or 1 pc. , whichever is greater, and are not continuous. The Specified quantity per reel is kept.

10.3 Pull Strength

Cover tape	5N min
------------	--------

10.4 Peeling off force of cover tape

Speed of Peeling off	300mm/min
Peeling off force	0.1N to 0.6N (minimum value is typical)

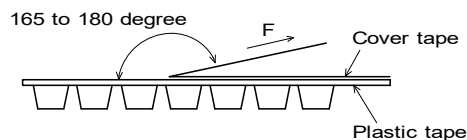

Reference Only

10.5 Dimensions of Leader-tape, Trailer and Reel

There shall be leader-tape (top tape and empty tape) and trailer-tape (empty tape) as follows.

【4mm-wide / plastic tape】

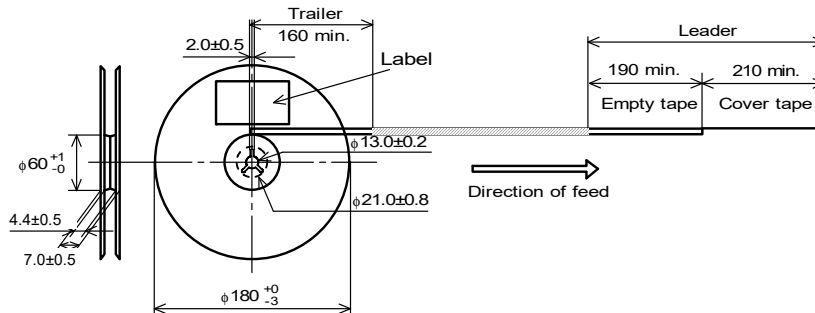

10.6 Marking for reel

Customer part number, MURATA part number, Inspection number(*1), RoHS Marking(*2), Quantity etc ...

*1) <Expression of Inspection No.>

□□ 0000 XXX
 (1) (2) (3)

- (1) Factory Code
- (2) Date

First digit : Year / Last digit of year
 Second digit : Month / Jan. to Sep. → 1 to 9, Oct. to Dec. → O,N,D
 Third, Fourth digit : Day

- (3) Serial No.

*2) <Expression of RoHS Marking >

ROHS - Y (△)
 (1) (2)

- (1) RoHS regulation conformity parts.
- (2) MURATA classification number

10.7 Marking for Outside package (corrugated paper box)

Customer name, Purchasing order number, Customer part number, MURATA part number, RoHS Marking (*2), Quantity, etc ...

10.8 Specification of Outer Case

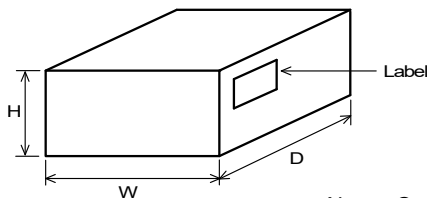

Outer Case Dimensions (mm)			Standard Reel Quantity in Outer Case (Reel)
W	D	H	
186	186	93	10(4mm-wide / plastic tape)

* Above Outer Case size is typical. It depends on a quantity of an order.

Reference Only

11. ⚠Caution

11.1 Restricted applications

Please contact us before using our products for the applications listed below which require especially high reliability for the prevention of defects which might directly cause damage to the third party's life, body or property.

- | | |
|-----------------------------------|---|
| (1) Aircraft equipment | (6) Transportation equipment (vehicles, trains, ships, etc.) |
| (2) Aerospace equipment | (7) Traffic signal equipment |
| (3) Undersea equipment | (8) Disaster/crime prevention equipment |
| (4) Power plant control equipment | (9) Data-processing equipment |
| (5) Medical equipment | (10) Applications of similar complexity and/or reliability requirements to the applications listed in the above |

11.2 Precautions on rating

Avoid using in exceeded the rated temperature range, rated voltage, or rated current. Usage when the ratings are exceeded could lead to wire breakage, burning, or other serious fault.

11.3 Inrush current

If an inrush current (or pulse current or rush current) that significantly exceeds the rated current is applied to the product, overheating could occur, resulting in wire breakage, burning, or other serious fault.

12. Precautions for Use

This product is for use only with reflow soldering. It is designed to be mounted by soldering. If you want to use other mounting method, for example, using a conductive adhesive, please consult us beforehand.

Also, if repeatedly subjected to temperature cycles or other thermal stress, due to the difference in the coefficient of thermal expansion with the mounting substrate, the solder (solder fillet part) in the mounting part may crack.

The occurrence of cracks due to thermal stress is affected by the size of the land where mounted, the solder volume, and the heat dissipation of the mounting substrate. Carefully design it when a large change in ambient temperature is assumed.

12.1 Land pattern designing

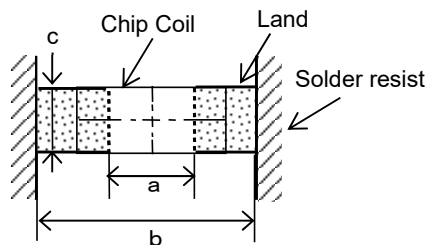

a	0.20
b	0.56
c	0.16

(in mm)

12.2 Flux, Solder

- Use rosin-based flux.
Don't use highly acidic flux with halide content exceeding 0.2(wt)% (chlorine conversion value).
Don't use water-soluble flux.
- Use Sn-3.0Ag-0.5Cu solder.
- Standard thickness of solder paste : 50 μm ~65 μm.

12.3 Reflow soldering conditions

- Pre-heating should be in such a way that the temperature difference between solder and product surface is limited to 150°C max. Cooling into solvent after soldering also should be in such a way that the temperature difference is limited to 100°C max.
Insufficient pre-heating may cause cracks on the product, resulting in the deterioration of products quality.
- Standard soldering profile and the limit soldering profile is as follows.
The excessive limit soldering conditions may cause leaching of the electrode and / or resulting in the deterioration of product quality.

Reference Only

• Reflow soldering profile

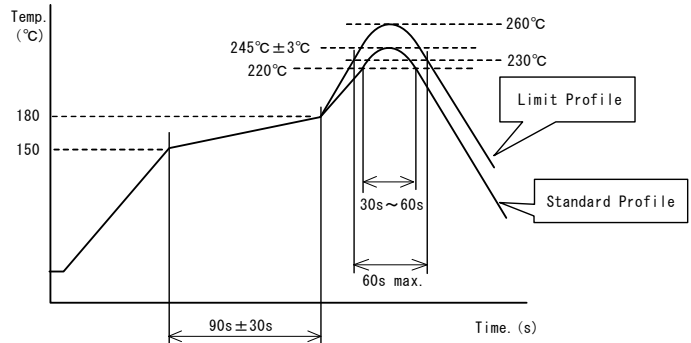

	Standard Profile	Limit Profile
Pre-heating	150°C ~ 180°C , 90s ± 30s	
Heating	above 220°C, 30s ~ 60s	above 230°C, 60s max.
Peak temperature	245°C ± 3°C	260°C, 10s
Cycle of reflow	2 times	

12.4 Reworking with soldering iron

Reworking with soldering iron is disapproved.

12.5 Solder Volume

• Solder shall be used not to be exceeded the upper limits as shown below.

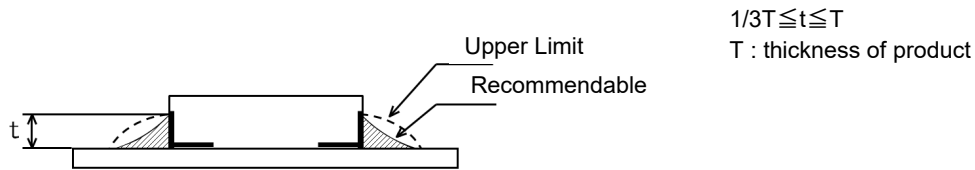

Accordingly increasing the solder volume, the mechanical stress to Chip is also increased. Exceeding solder volume may cause the failure of mechanical or electrical performance and become easy to tilt.

12.6 Attention regarding P.C.B. bending

The following shall be considered when designing and laying out P.C.B.'s.

- (1) P.C.B. shall be designed so that products are not subject to the mechanical stress due to warping the board.

[Products direction]

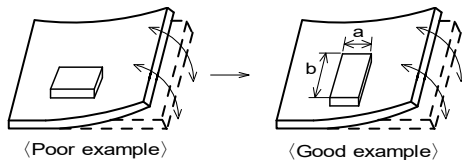

Products shall be located in the sideways direction (Length: $a < b$) to the mechanical stress.

Reference Only

(2) Components location on P.C.B. separation.

It is effective to implement the following measures, to reduce stress in separating the board.

It is best to implement all of the following three measures; however, implement as many measures as possible to reduce stress.

Contents of Measures	Stress Level
(1) Turn the mounting direction of the component parallel to the board separation surface.	A > D *1
(2) Add slits in the board separation part.	A > B
(3) Keep the mounting position of the component away from the board separation surface.	A > C

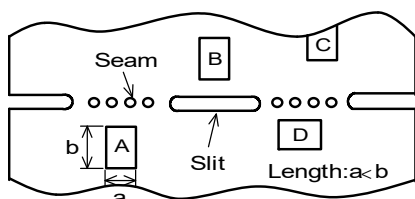

*1 A > D is valid when stress is added vertically to the perforation as with Hand Separation. If a Cutting Disc is used, stress will be diagonal to the PCB, therefore A > D is invalid.

(3) Mounting Components Near Screw Holes

When a component is mounted near a screw hole, it may be affected by the board deflection that occurs during the tightening of the screw. Mount the capacitor in a position as far away from the screw holes as possible.

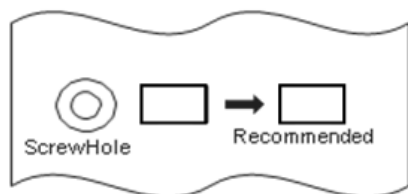

12.7 Cleaning Conditions

Products shall be cleaned on the following conditions.

- (1) Cleaning temperature shall be limited to 60°C max.(40°C max for IPA)
- (2) Ultrasonic cleaning shall comply with the following conditions with avoiding the resonance phenomenon at the mounted products and P.C.B.
 Power : 20 W / l max. Frequency : 28kHz to 40kHz Time : 5 min max.
- (3) Cleaner
 1. Alcohol type cleaner
Isopropyl alcohol (IPA)
 2. Aqueous agent
PINE ALPHA ST-100S
- (4) There shall be no residual flux and residual cleaner after cleaning.
 In the case of using aqueous agent, products shall be dried completely after rinse with de-ionized water in order to remove the cleaner.
- (5) Other cleaning Please contact us.

12.8 Resin coating

When products are coated with resin, please contact us in advance.

Reference Only

12.9 Handling of a substrate

(1) There is a possibility of chip cracking caused by PCB expansion/contraction with heat, because stress on a chip is different depending on PCB material and structure.

When the thermal expansion coefficient greatly differs between the board used for mounting and the chip, it will cause cracking of the chip due to the thermal expansion and contraction.

The chip is assumed to be mounted on the PCB of glass-epoxy material, and we don't test with other PCB material which has different thermal expansion coefficient from Glass-epoxy.

When other PCB materials are considered, please be sure to evaluate by yourself.

(2) After mounting products on a substrate, do not apply any stress to the product caused by bending or twisting to the substrate when cropping the substrate, inserting and removing a connector from the substrate or tightening screw to the substrate.

Excessive mechanical stress may cause cracking in the product.

In case of the mounting on flexible PCB, there is a possibility of chip cracking caused by mechanical stress even from small bending or twisting.

When the flexible PCB is considered, please be sure to evaluate by yourself.

Bending

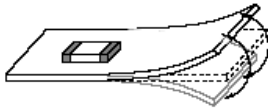

Twisting

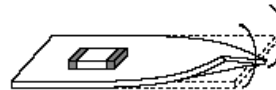

12.10 Storage and Handling Requirements

(1) Storage period

Use the products within 12 months after delivered.

Solderability should be checked if this period is exceeded.

(2) Storage conditions

• Products should be stored in the warehouse on the following conditions.

Temperature : -10°C ~ 40°C

Humidity : 15% to 85% relative humidity No rapid change on temperature and humidity.

• Products should not be stored on bulk packaging condition to prevent the chipping of the core and the breaking of winding wire caused by the collision between the products.

• Products should be stored on the palette for the prevention of the influence from humidity, dust and so on.

• Products should be stored in the warehouse without heat shock, vibration, direct sunlight and so on.

(3) Handling Condition

Care should be taken when transporting or handling product to avoid excessive vibration or mechanical shock.

12.11 Mounting conditions

Check the mounting condition before using.

Using mounting conditions (nozzles, equipment conditions, etc.) that are not suitable for products may lead to pick up errors, misalignment, or damage to the product.

12.12 Operating environment

Do not use this product under the following environmental conditions as it may cause deterioration of product quality.

(1) In the corrodible atmosphere such as acidic gases, alkaline gases, chlorine, sulfur gases, organic gases and etc. (the sea breeze, Cl₂, H₂S, NH₃, SO₂, NO₂, etc)

(2) In the atmosphere where liquid such as organic solvent, may splash on the products.

(3) In the atmosphere where the temperature/humidity changes rapidly and it is easy to dew.

Reference Only

12.13 Mounting density

If this product is placed near heat-generating products, be sure to implement sufficient heat-dissipating measures. If this product is subjected to a significant amount of heat from other products, this could adversely affect product quality, resulting in a circuit malfunction or failure of the mounted section. Also, be sure that the product is used in a manner so that the heat that the product is subjected to from other products does not exceed the upper limit of the rated operating temperature for the product.

13. Note

- (1) Please make sure that your product has been evaluated in view of your specifications with our product being mounted to your product.
- (2) You are requested not to use our product deviating from the reference specifications.
- (3) The contents of this reference specification are subject to change without advance notice.
Please approve our product specifications or transact the approval sheet for product specifications before ordering.

<Electrical Performance: Measuring Method of Inductance/Q>

(1) Residual elements and stray elements of test fixture can be described by F-parameter shown in following.

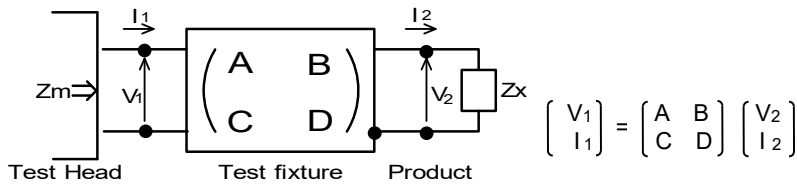

(2) The impedance of chip coil Z_x and measured value Z_m can be described by input/output current/voltage.

$$Z_m = \frac{V_1}{I_1}, \quad Z_x = \frac{V_2}{I_2}$$

(3) Thus, the relation between Z_x and Z_m is following;

$$Z_x = \alpha \frac{Z_m - \beta}{1 - Z_m \Gamma} \quad \text{where, } \alpha = D / A = 1$$

$$\beta = B / D = Z_{sm} - (1 - Y_{om}) Z_{ss}$$

$$\Gamma = C / A = Y_{om}$$

$\left[\begin{array}{l} Z_{sm}: \text{measured impedance of short chip} \\ Z_{ss}: \text{residual impedance of short chip (0.19nH)} \\ Y_{om}: \text{measured admittance when opening the fixture} \end{array} \right]$

(4) L_x and Q_x shall be calculated with the following equation.

$$L_x = \frac{\text{Im}(Z_x)}{2\pi f}, \quad Q_x = \frac{\text{Im}(Z_x)}{\text{Re}(Z_x)}$$

L_x : Inductance of chip coil
 Q_x : Q of chip coil
 f : Measuring frequency

X-ON Electronics

Largest Supplier of Electrical and Electronic Components

Click to view similar products for [Power Inductors - SMD category](#):

Click to view products by [Murata manufacturer](#):

Other Similar products are found below :

[SPD62R-472M](#) [LLQPB201214T1R0M](#) [LLXND3030QKT470MNG](#) [LLQPB160807T4R7M](#) [LLAPB2016KKTR33M](#)
[LBXND4040TKL330MDG](#) [LSQEA201212T100M](#) [PA4300.474NLT](#) [LVS505020-1R0T-N](#) [LVS505040-1R2T-N](#) [LVS606020-1R5M-N](#)
[LVS606028-6R8M-N](#) [LVS606045-102M-N](#) [LVS606045-150M-N](#) [LVS606045-1R8M-N](#) [LVS606045-6R8M-N](#) [LVS808040-2R0M-N](#)
[LVS808040-330M-N](#) [LVS808040-4R7M-N](#) [MHCI06030-R56M-R8](#) [SCD0403T-470M-N](#) [SCD0403T-6R8K-N](#) [SCD0504T-101M-N](#)
[SCD0504T-120M-N](#) [SCD0504T-221M-N](#) [SCD0504T-470M-N](#) [SCD0504T-471M-N](#) [SCD0705T-180M-N](#) [SCD0705T-221M-N](#) [SCD0705T-470M-N](#) [SCD1005T-101M-N](#) [SCD1005T-221M-N](#) [SCD1005T-470M-N](#) [SSL1306T-101M-N](#) [LQB15NNR27K10D](#) [201610CDMCDDS-R47MC](#) [201610CDMCDDS-1R0MC](#) [201610CDMCDDS-R68MC](#) [LSQPB201210T220M](#) [LBCNF2012KKTR24MA](#) [LSQEA201212T220K](#)
[LSENC2016KKT1R0M](#) [LSQNB160808T470M](#) [LSBHB1608KKT2R2MG](#) [LSQPB160807T2R2M](#) [LSQEA201212T101K](#) [DEM8045Z-5R6N=P3](#) [LCXND3030QKT4R7MNG](#) [LSQPA322525T6R8MR](#) [LCXNH8080YKL101MJG](#)