

1. Application

This specification shall be applied to the ESD Protection Device.

- LXES1UBAB1-007
- LXES1UBAA1-096
- LXES1TBCC2-004
- LXES1TBBB2-013
- LXES2SBAA4-016
- LXES2SBBB4-026
- LXES2SBAA4-114
- LXES2TBCC4-028
- LXES4XBAA6-027
- LXESEABAA6-046



2. Part Number Configuration

LXES 1U B AB 1 - 007
 ① ② ③ ④ ⑤ ⑥

- ① Product ID (LXES = ESD Protection device)
- ② Dimension Code

Unit : mm

Code	Dimension	package (serial number)	Code	Dimension	package (serial number)
1U	1.0 x 0.6	DFN1006P2E (007) DFN1006P2X (096)	2T	2.5 x 1.0	DFN2510P10E (028)
1T	1.6 x 1.6	QFN1616P6E (004/013)	4X	4.9 x 3.0	MSOP-8L (027)
2S	2.9 x 2.8	SOT23-6L (016/026) SOT23-5L (114)	EA	4.1x2.0	DFN4120P10E(046)

- ③ Type(B:Silicon ESD)
- ④ Control Code
- ⑤ Number of channel
- ⑥ Serial Number

※RoHS Compliant
Halogen free
T/R only.

3. CHARACTERISTICS

3-1 Ratings

Parameter	Package	Operating Temperature	Storage Temperature
Symbol		T_{OP}	T_{STO}
Unit		$^{\circ}C$	$^{\circ}C$
LXES1UBAB1-007	DFN1006P2E	-40 to +85	-40 to +125
LXES1UBAA1-096	DFN1006P2X	-40 to +85	-40 to +125
LXES1TBCC2-004	QFN1616P6E	-40 to +85	-40 to +125
LXES1TBAB2-013		-40 to +85	-40 to +125
LXES2SBAA4-016	SOT23-6L	-40 to +85	-40 to +125
LXES2SBBB4-026		-40 to +85	-40 to +125
LXES2SBAA4-114	SOT23-5L	-40 to +85	-40 to +125
LXES2TBCC4-028	DFN2510P10E	-40 to +85	-40 to +125
LXES4XBAA6-027	MSOP-8L	-40 to +85	-40 to +125
LXESEABAA6-046	DFN4120P10E	-40 to +85	-40 to +125

3-2 Electrical Characteristics (T=25°C)

Parameter	Reverse Working Voltage	Channel Leakage Current	Break down voltage	ESD per IEC 61000-4-2(air)	ESD per IEC 61000-4-2 (contact)	Capacitance
Symbol	V_{RWM}	I_{leak}	V_{br}	V_{esd}	V_{esd}	C
Unit	V	μA	V	kV	kV	pF
Condition		$V_{P_{in1}}=5V, V_{P_{in2}}=0V$	$I_{br}=1mA, P_{in1}$ to P_{in2}	$T_a=25^{\circ}C$	$T_a=25^{\circ}C$	$V_{P_{in1,2}}=0V, f = 1MHz, \text{Between Channel pins}$
LXES1UBAB1-007	+/-17.5	1.0 (max)	18 (min)	+/- 15	+/- 8	0.5
LXES1UBAA1-096	+/-5.5	1.0 (max)	5.8 (min)	+/- 15	+/- 12	8

Parameter	Reverse Working Voltage	Channel Leakage Current	Break down voltage	ESD per IEC 61000-4-2(air)	ESD per IEC 61000-4-2 (contact)	Capacitance
Symbol	V_{RWM}	I_{leak}	V_{br}	V_{esd}	V_{esd}	C
Unit	V	μA	V	kV	kV	pF
Condition		$V_{pin5}=5V, V_{pin2}=0V, V_{CH}=0-5V$	$I_{br}=1mA$	$T_a=25^{\circ}C$	$T_a=25^{\circ}C$	$V_{pin5} = 5V, V_{pin2} = 0V, V_{IN} = 2.5V, f = 1MHz, \text{Any I/O pin to Ground}$
LXES1TBCC2-004	+/-5.5	1.0 (max)	6 (min)	+/- 15	+/- 12	0.55

Parameter	Reverse Working Voltage	Channel Leakage Current	Break down voltage	ESD per IEC 61000-4-2(air)	ESD per IEC 61000-4-2 (contact)	Capacitance
Symbol	V_{RWM}	I_{leak}	V_{br}	V_{esd}	V_{esd}	C
Unit	V	μA	V	kV	kV	pF
Condition		$V_{pin5}=5V, V_{pin2}=0V, V_{CH}=0-5V$	$I_{br}=1mA$	$T_a=25^{\circ}C$	$T_a=25^{\circ}C$	$V_{pin2} = 5V, V_{pin5} = 0V, V_{IN} = 2.5V, f = 1MHz, \text{Any I/O pin to Ground}$
LXES1TBAB2-013	+/-5.5	1.0 (max)	6 (min)	+/- 15	+/- 12	0.55

Parameter	Reverse Working Voltage	Channel Leakage Current	Break down voltage	ESD per IEC 61000-4-2(air)	ESD per IEC 61000-4-2 (contact)	Capacitance
Symbol	VRWM	I _{leak}	V _{br}	V _{esd}	V _{esd}	C
Unit	V	uA	V	kV	kV	pF
Condition		V _{pin5} =5V, V _{pin2} =0V, V _{CH} =0-5V	I _{br} =1mA	Ta=25°C	Ta=25°C	V _{pin5} = 5V, V _{pin2} = 0V, V _{IN} = 2.5V, f = 1MHz, Any I/O pin to Ground
LXES2SBAA4-016	+/-5.5	1.0 (max)	6 (min)	+/- 15	+/- 10	0.55
LXES2SBBB4-026	+/-5.5	1.0 (max)	6 (min)	+/- 15	+/- 10	1.0

Parameter	Reverse Working Voltage	Channel Leakage Current	Break down voltage	ESD per IEC 61000-4-2(air)	ESD per IEC 61000-4-2 (contact)	Capacitance
Symbol	V _{RWM}	I _{leak}	V _{br}	V _{esd}	V _{esd}	C
Unit	V	uA	V	kV	kV	pF
Condition		V _{pin1,3,4,5} =5V, V _{pin2} =0V	I _{br} =1mA	Ta=25°C	Ta=25°C	V _R =0V, f=1MHz
LXES2SBAA4-114	+/-5.0	2.5 (max)	6.1 (min)	+/- 22	+/- 15	12

Parameter	Reverse Working Voltage	Channel Leakage Current	Break down voltage	ESD per IEC 61000-4-2(air)	ESD per IEC 61000-4-2 (contact)	Capacitance
Symbol	V _{RWM}	I _{leak}	V _{br}	V _{esd}	V _{esd}	C
Unit	V	uA	V	kV	kV	pF
Condition		V _{pin3,8} =0V, V _{pin1,2,4,5} =0-5V	I _{br} =1mA	Ta=25°C	Ta=25°C	V _{pin3,8} =0V, V _{in} =2.5V, f=1MHz
LXES2TBCC4-028	+/-5.5	1.5 (max)	6 (min)	+/- 15	+/- 10	0.5

Parameter	Reverse Working Voltage	Channel Leakage Current	Break down voltage	ESD per IEC 61000-4-2(air)	ESD per IEC 61000-4-2 (contact)	Capacitance
Symbol	V _{RWM}	I _{leak}	V _{br}	V _{esd}	V _{esd}	C
Unit	V	uA	V	kV	kV	pF
Condition		V _{pin6} =5V, V _{pin7} =0V, V _{CH} =0-5V	I _{br} =1mA	Ta=25°C	Ta=25°C	V _{pin6} =5V, V _{pin7} =0V, V _{in} =2.5V, f=1MHz
LXES4XBAA6-027	+/-5.5	1.0 (max)	6 (min)	+/- 15	+/- 8	0.27
LXESEABAA6-046	+/-5.5	1.0 (max)	6 (min)	+/- 15	+/- 8	0.27

3-3 Typical Characteristics

LXES1UBAB1-007

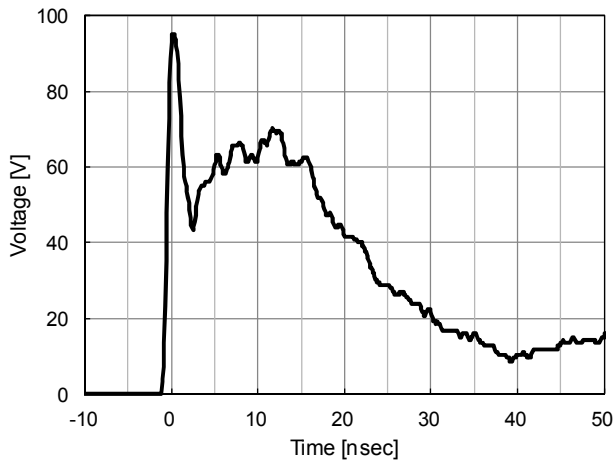

ESD Waveform(IEC61000-4-2:8kV Contact)

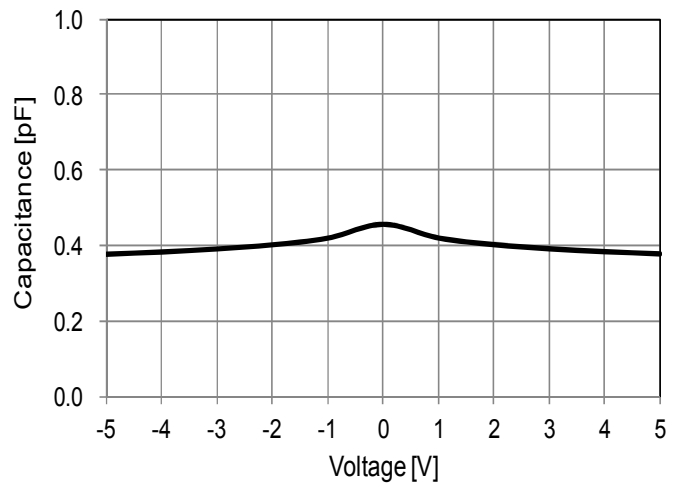

Voltage—Capacitance Characteristic

LXES1UBAA1-096

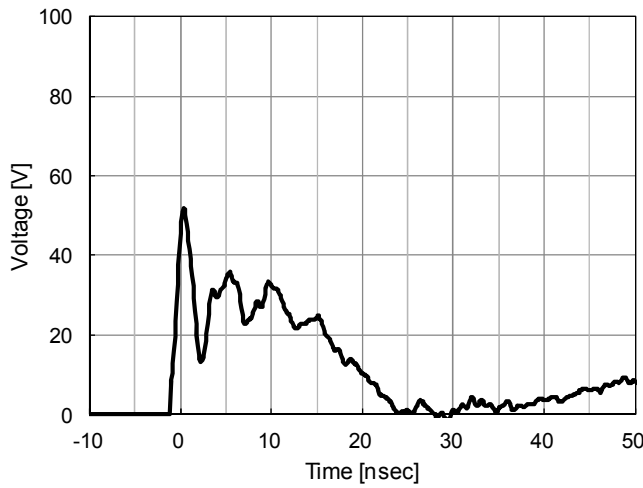

ESD Waveform(IEC61000-4-2:8kV Contact)

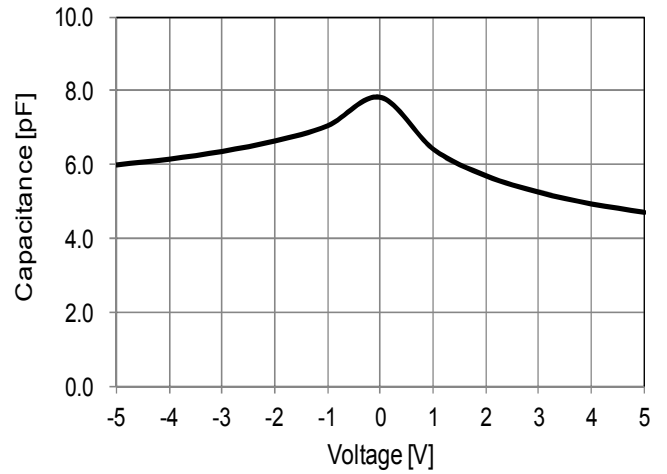

Voltage—Capacitance Characteristic

LXES1TBCC2-004

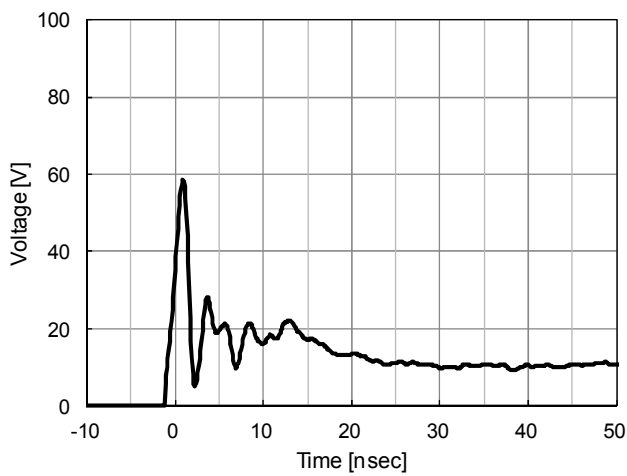

ESD Waveform(IEC61000-4-2:8kV Contact)

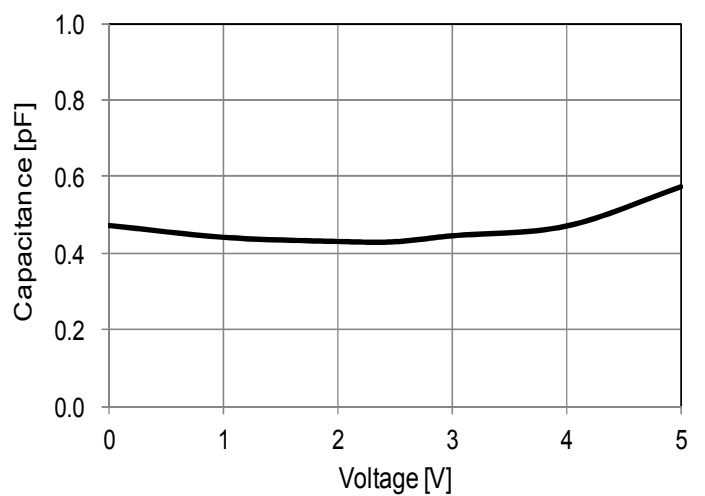

Voltage—Capacitance Characteristic

LXES1TB3B2-013

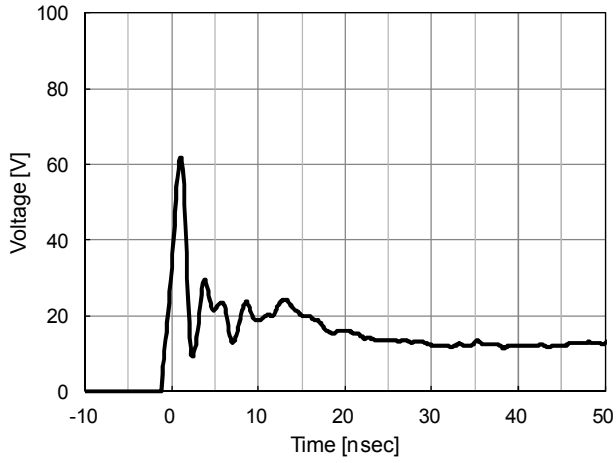

ESD Waveform(IEC61000-4-2:8kV Contact)

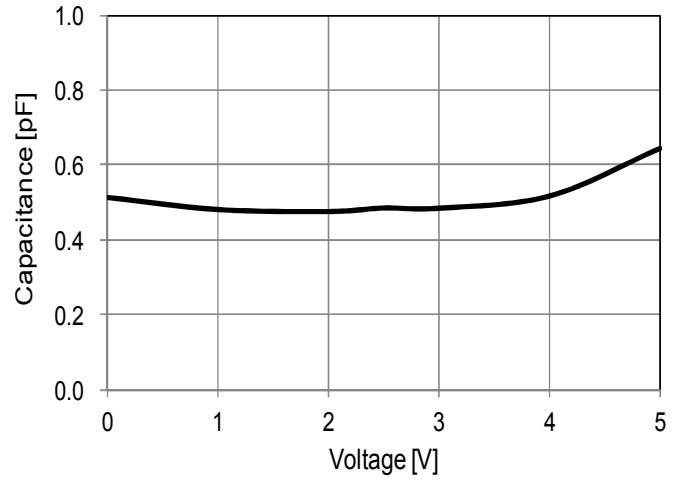

Voltage – Capacitance Characteristic

LXES2SBAA4-016

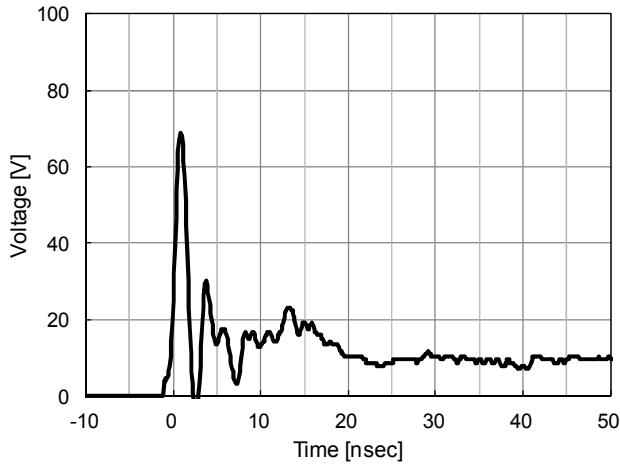

ESD Waveform(IEC61000-4-2:8kV Contact)

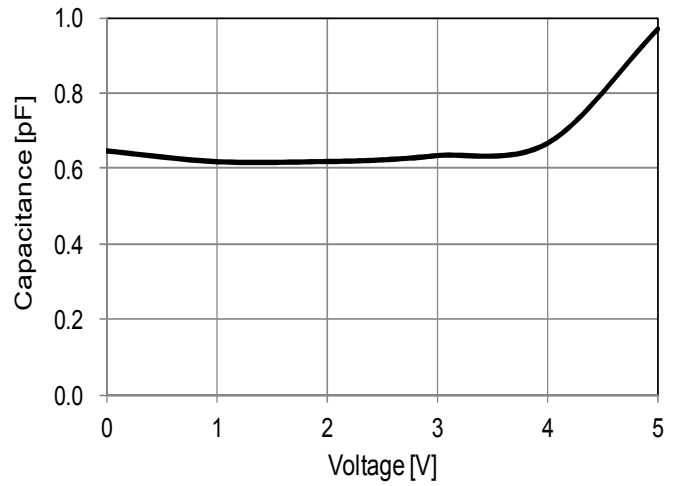

Voltage – Capacitance Characteristic

LXES2SBBB4-026

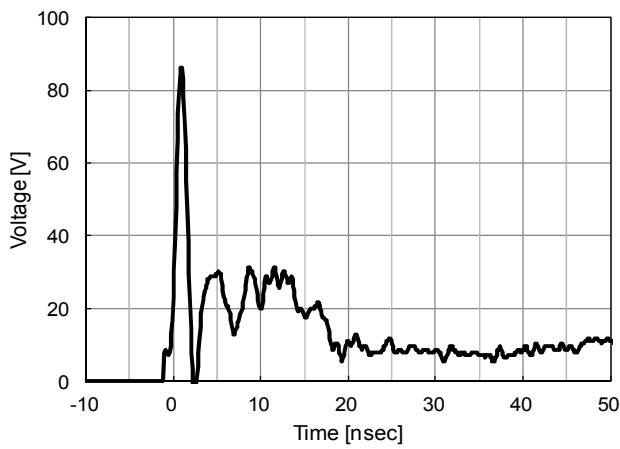

ESD Waveform(IEC61000-4-2:8kV Contact)

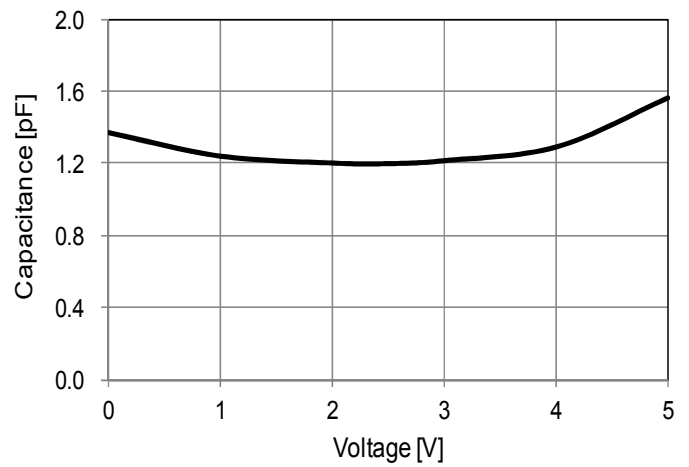

Voltage – Capacitance Characteristic

LXES2SBAA4-114

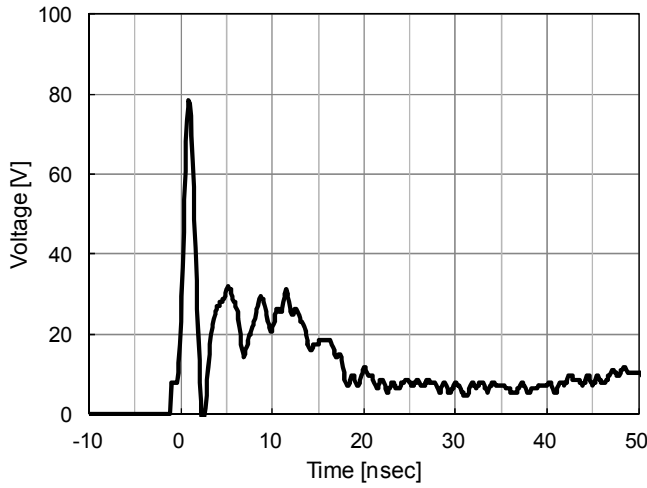

ESD Waveform(IEC61000-4-2:8kV Contact)

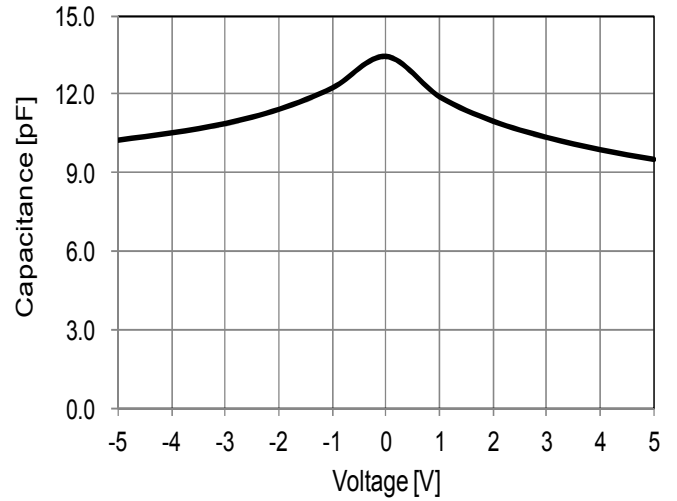

Voltage – Capacitance Characteristic

LXES2TBCC4-028

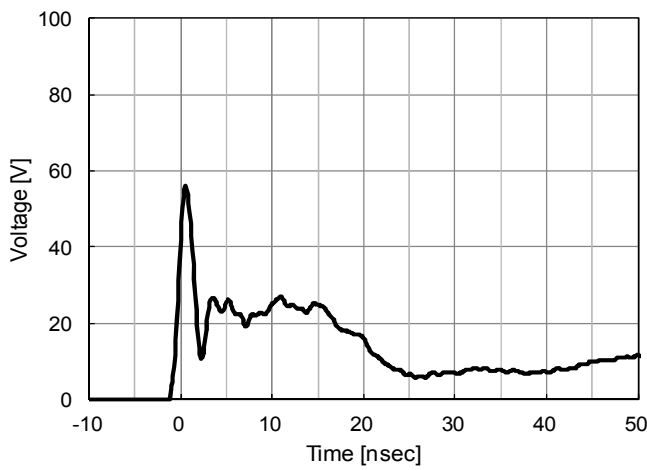

ESD Waveform(IEC61000-4-2:8kV Contact)

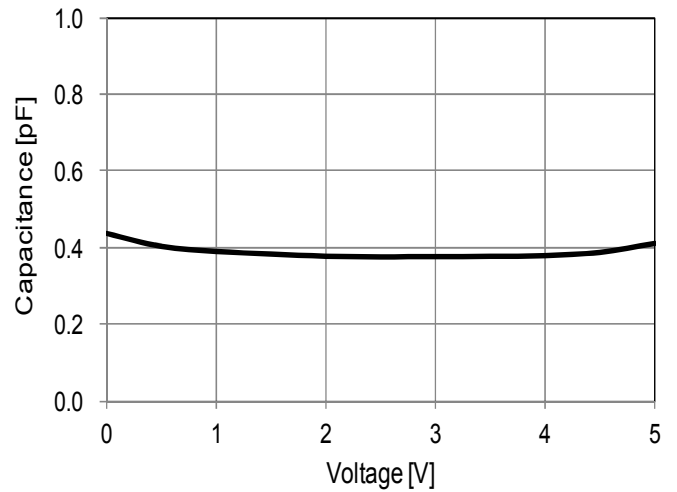

Voltage – Capacitance Characteristic

LXES4XBAA6-027

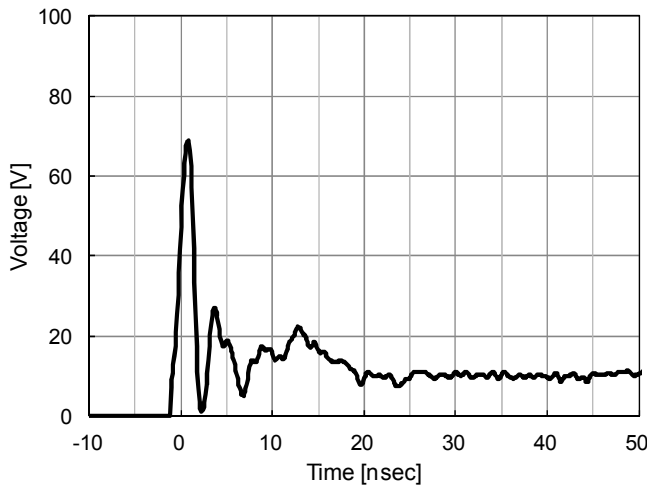

ESD Waveform(IEC61000-4-2:8kV Contact)

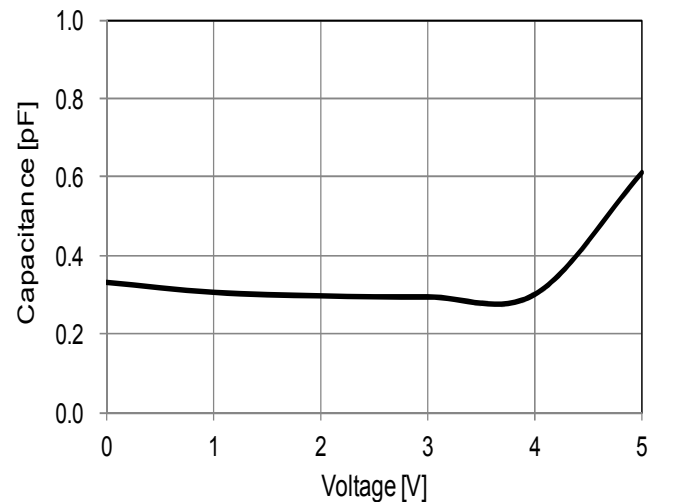

Voltage – Capacitance Characteristic

LXESEABAA6-046

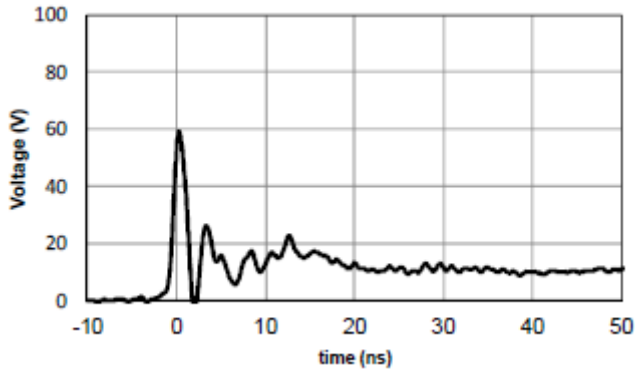

ESD Waveform(IEC61000-4-2:8kV Contact)

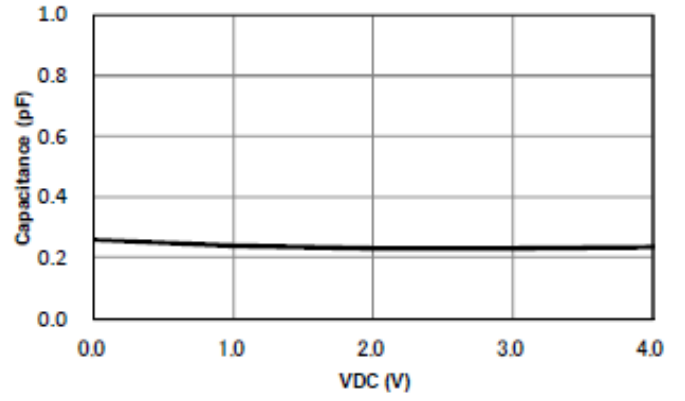

Voltage—Capacitance Characteristic

4. CONSTRUCTION, DIMENSIONS
 (1) DFN1006P2E

4 - 1 - 1 DIMENSIONS

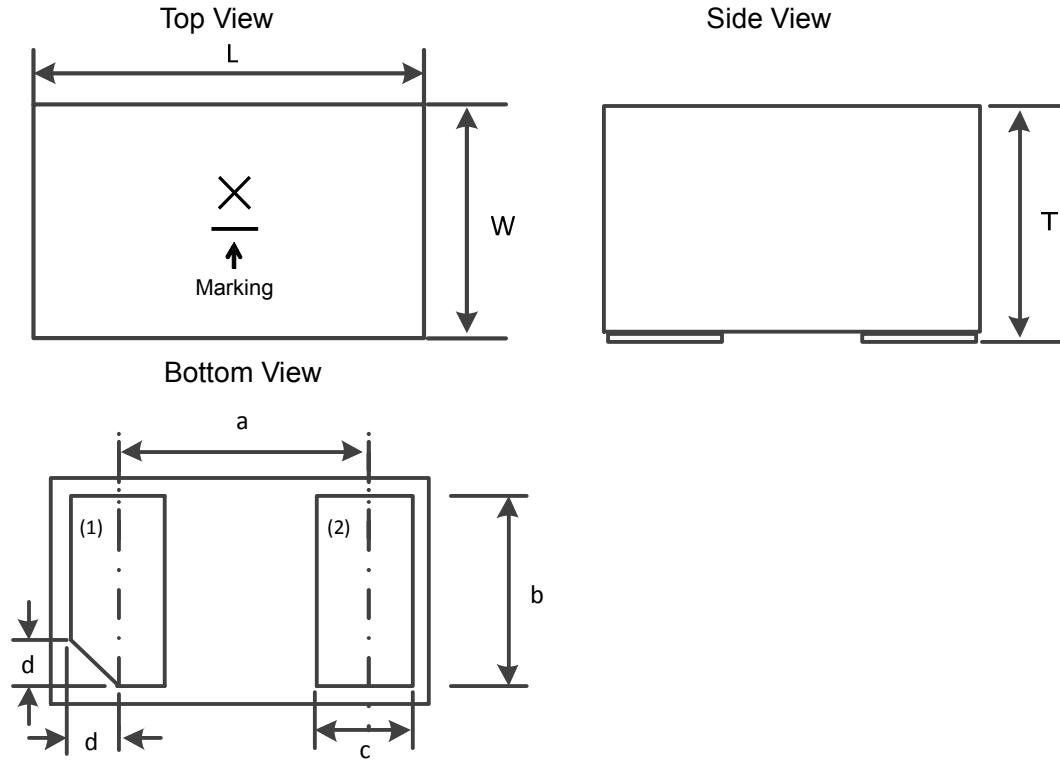

Unit : mm

symbol	size
L	1.0+/-0.05
W	0.6+/-0.05
T	0.6 max
a	(0.65)

symbol	size
b	0.5+/-0.05
c	0.25+/-0.05
d	(0.125)

4 - 1 - 2 Pin Configuration

No.	Terminal Name
1	Line-1/GND
2	GND/Line-1

4 - 1 - 3 Circuit Diagram

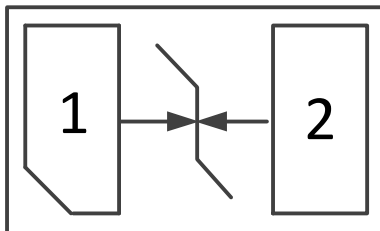

(2) DFN1006P2X

4 - 2 - 1 DIMENSIONS

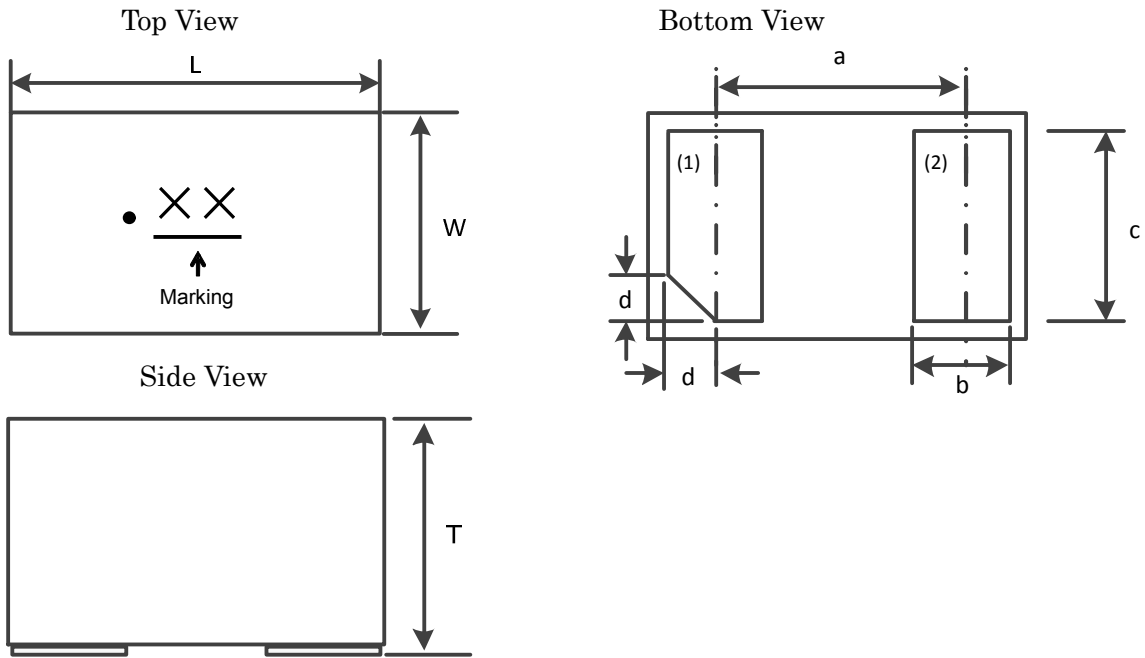

symbol	size
L	1.0+/-0.05
W	0.6+/-0.05
T	0.5 max
a	(0.45)

symbol	size
b	0.25+/-0.05
c	0.50+/-0.05
d	(0.125)

4 - 2 - 2 Pin Configuration

No.	Terminal Name
1	Line-1/GND
2	GND/Line-1

4 - 2 - 3 Circuit Diagram

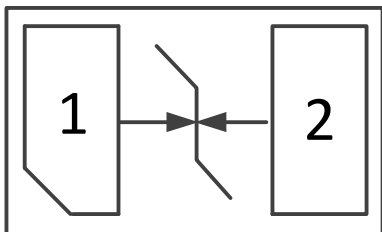

(3) QFN1616P6E

4 - 3 - 1 DIMENSIONS

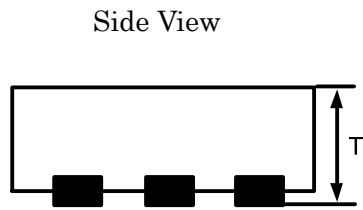
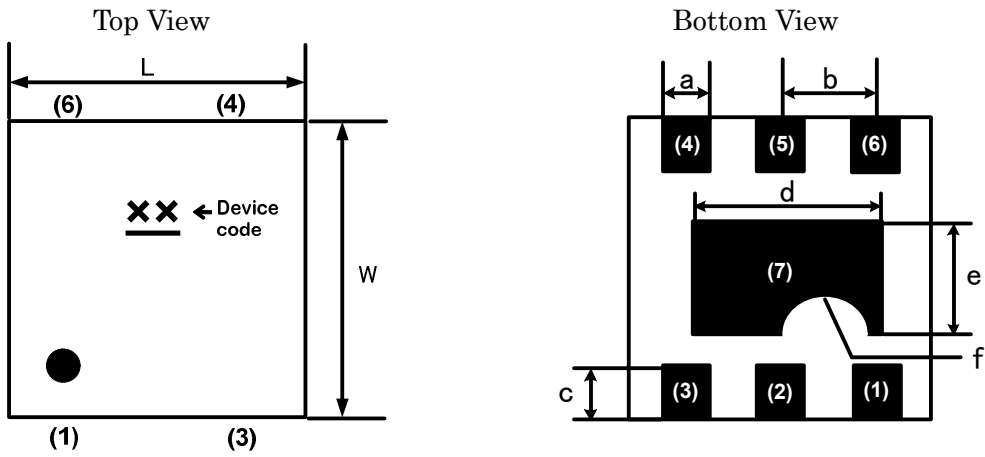

symbol	size
L	1.6+/-0.05
W	1.6+/-0.05
T	0.6 max
a	0.25+/-0.05
b	(0.5)

Unit : mm

symbol	size
c	0.275+/-0.05
d	(1.0)
e	(0.6)
f	R0.2

4 - 3 - 2 Pin Configuration

LXES1TBCC2-004

No.	Terminal Name
1	I/O 1
2	GND
3	I/O 2
4	NC

No.	Terminal Name
5	VDD
6	NC
7	NC

LXES1TBBB2-013

No.	Terminal Name
1	I/O 1
2	VDD
3	I/O 2
4	NC

No.	Terminal Name
5	GND
6	NC
7	NC

4 - 3 - 3 Circuit Diagram

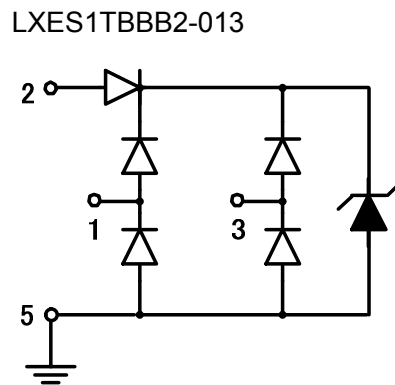
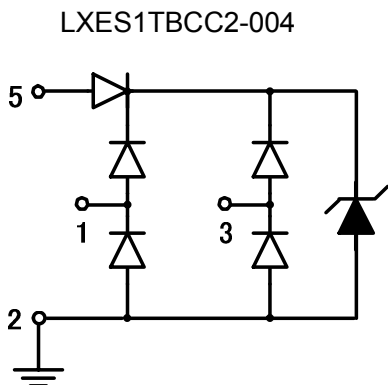

(4) SOT23-6L

4 - 4 - 1 DIMENSIONS

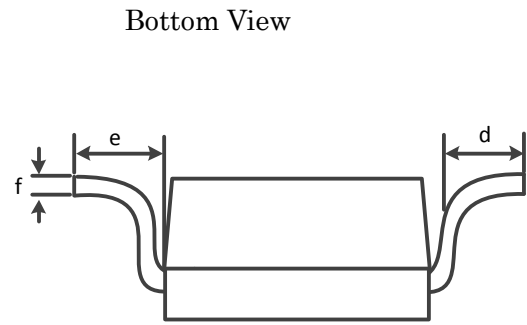
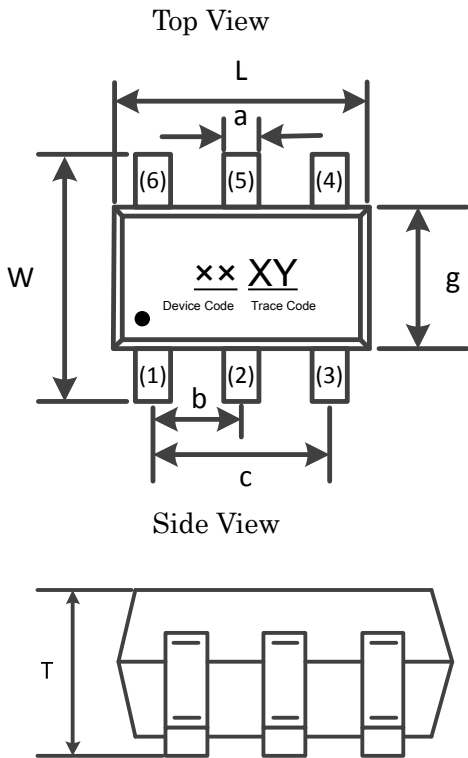

Unit : mm

symbol	size
L	2.9 typ
W	2.8 typ
T	1.45 max
a	0.4±0.10
b	(0.95)

symbol	size
c	(1.9)
d	1.3 max
e	0.15 max
f	0.14±0.06
g	(0.6)

4 - 4 - 2 Pin Configuration

No.	Terminal Name
1	I/O 1
2	GND
3	I/O 2

No.	Terminal Name
4	I/O 3
5	VDD
6	I/O 4

4 - 4 - 3 Circuit Diagram

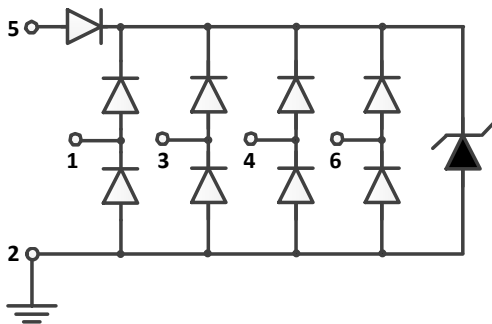

(5) SOT23-5L

4 - 5 - 1 DIMENSIONS

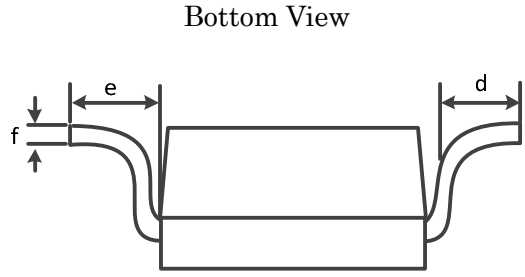
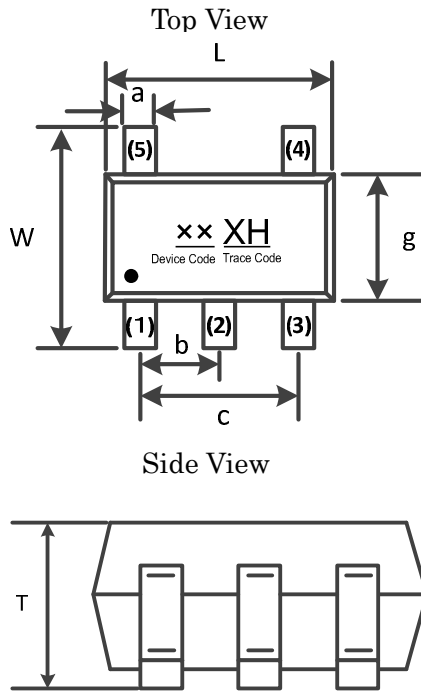

Unit : mm

symbol	size
L	2.9±0.2
W	2.8±0.2
T	1.45 max
a	0.4±0.10
b	(0.95)

symbol	size
c	(1.9)
d	(0.45)
e	(0.6)
f	0.21 max
g	1.8 max

4 - 5 - 2 Pin Configuration

No.	Terminal Name
1	I/O 1
2	GND
3	I/O 2

No.	Terminal Name
4	I/O 3
5	I/O 4

4 - 5 - 3 Circuit Diagram

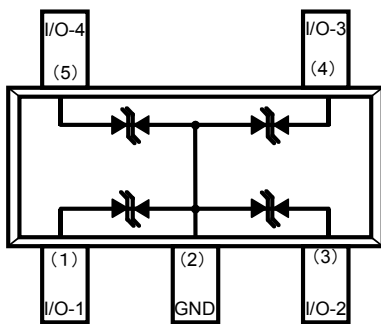

(6) DFN2510P10E

4 - 6 - 1 DIMENSIONS

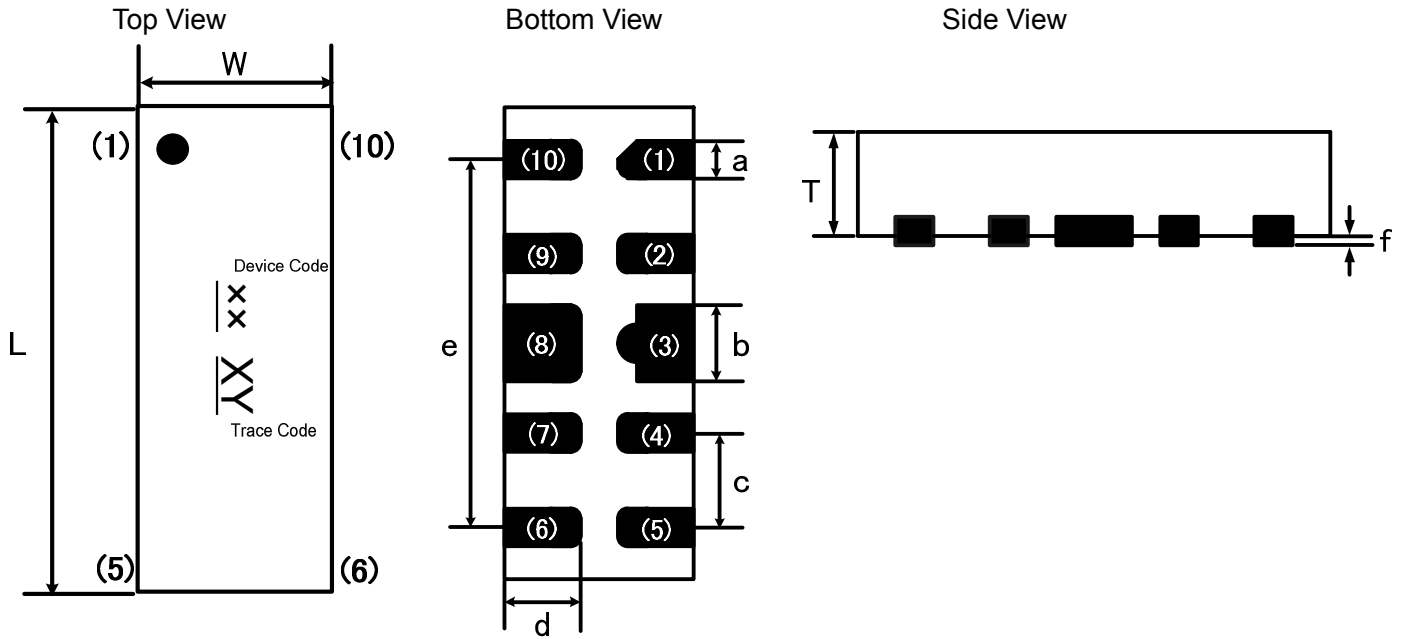

Unit : mm

symbol	size
L	2.5+/-0.05
W	1.0+/-0.05
T	0.60 max
a	0.20+/-0.05
b	0.40+/-0.05

symbol	size
c	(0.5)
d	0.40+/-0.05
e	(1.95)
f	0.05 max

4 - 6 - 2 Pin Configuration

No	Terminal Name
1	Line-1
2	Line-2
3	GND
4	Line-3
5	Line-4

No	Terminal Name
6	NC
7	NC
8	GND
9	NC
10	NC

4 - 6 - 3 Circuit Diagram

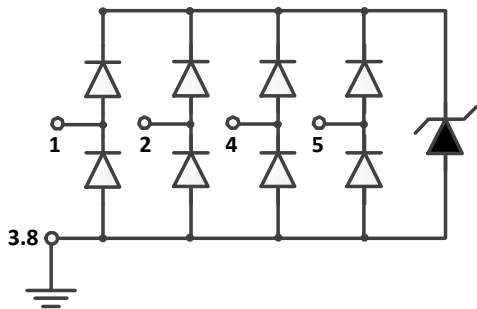

(7) MSOP-8L

4 - 7 - 1 DIMENSIONS

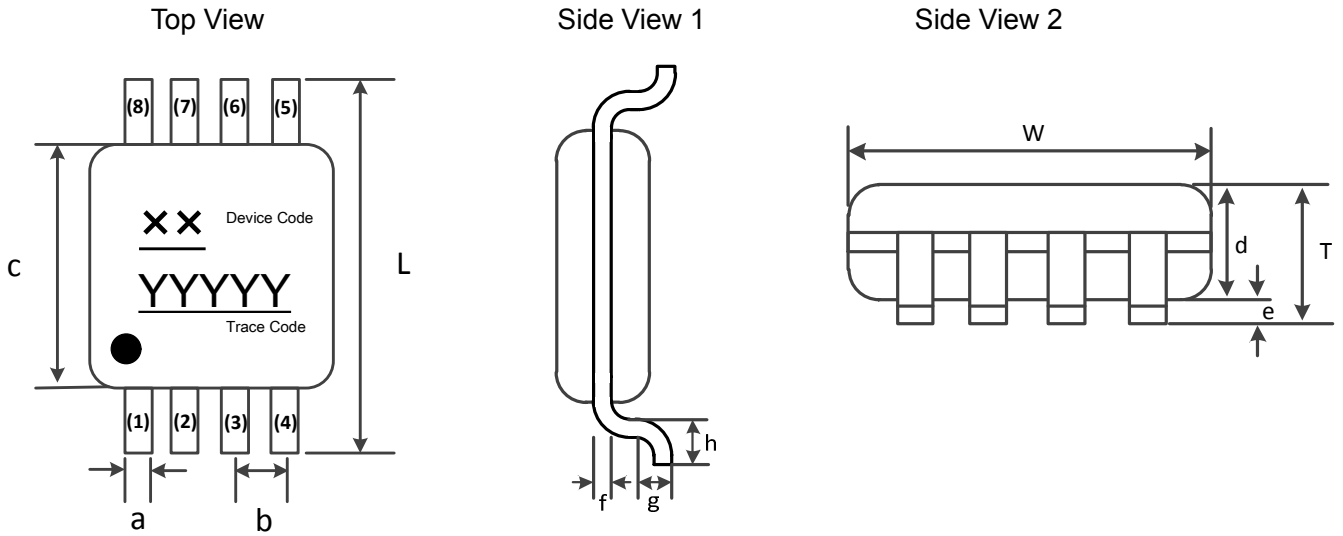

Unit : mm

symbol	size
L	4.9+/-0.15
W	3.0+/-0.10
T	1.1 max
a	0.30+0.08/-0.02
b	(0.65)
c	3.0+/-0.10

symbol	size
d	0.95 max
e	0.15 max
f	0.15+0.08/-0.02
g	(0.25)
h	(0.55)

4 - 7 - 2 Pin Configuration

No.	Terminal Name
1	I/O 1
2	I/O 2
3	I/O 3
4	I/O 4

No.	Terminal Name
5	I/O 5
6	I/O 6
7	GND
8	VDD

4 - 7 - 3 Circuit Diagram

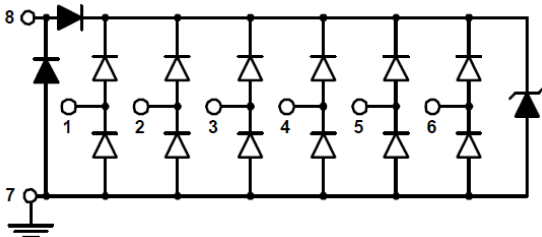

(7) DFN4120P10E

4 - 8 - 1 DIMENSIONS

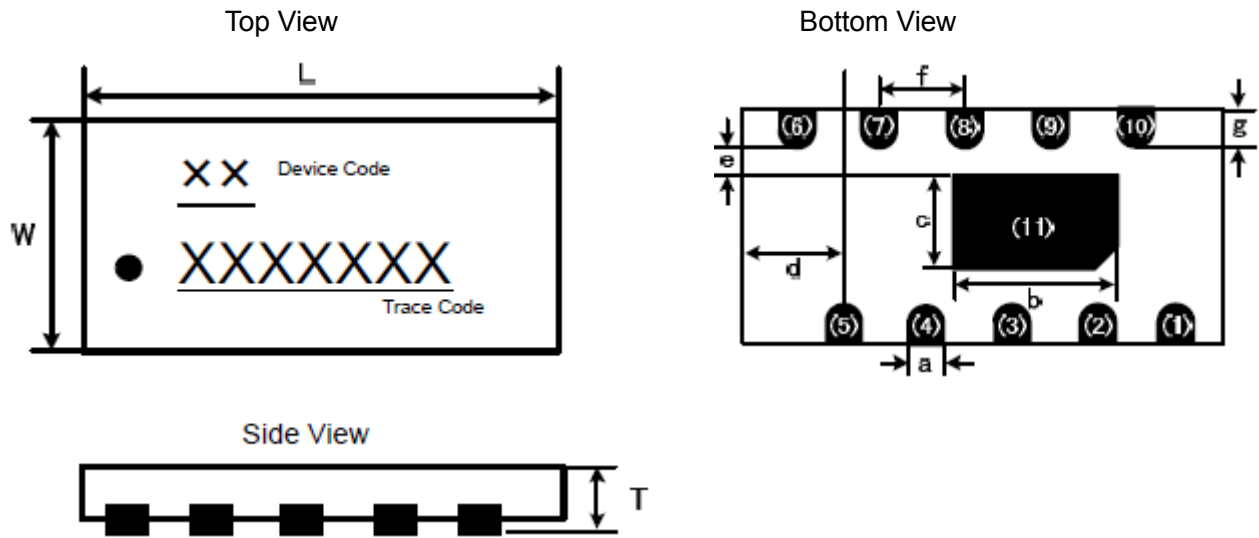

Unit : mm

symbol	size
L	4.1+/-0.05
W	2.0+/-0.05
T	0.55 max
a	0.20+/-0.05
b	1.4+/-0.1

symbol	size
c	0.8+/-0.10
d	(0.65)
e	0.2min
f	0.30+/-0.05
g	0.30+/-0.05

4 - 8 - 2 Pin Configuration

No.	Terminal Name
1	I/O 1
2	VDD
3	NC
4	I/O 2
5	I/O 3
6	I/O 4

No.	Terminal Name
7	I/O 5
8	NC
9	GND
10	I/O 6
11	NC

4 - 8 - 3 Circuit Diagram

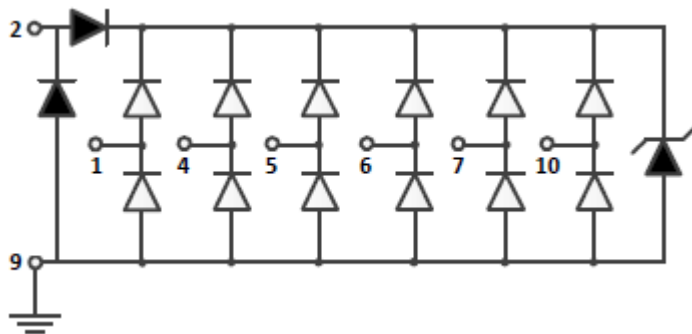

5. Reliability Test

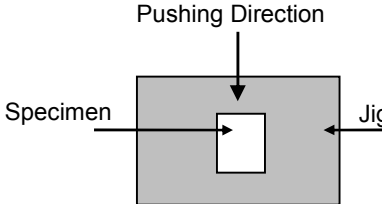
No.	Items		Specifications	Test Methods	Number	Result (Fail)
1	Vibration Resistance		No severe damages Satisfy dimension specifications	Solder specimens on the testing jig (glass fluorine boards) shown in appended Fig.1 by a Pb free solder. The soldering shall be done either by iron or reflow and be conducted with care so that the soldering is uniform and free of defect such as by heat shock. Frequency : 10~2000 Hz Acceleration : 196 m/s ² Direction : X,Y,Z 3 axis Period : 2 h on each direction Total 6 h.	22	G (0)
2	Shock			Solder specimens on the testing jig (glass fluorine boards) shown in appended Fig.1 by a Pb free solder. The soldering shall be done either by iron or reflow and be conducted with care so that the soldering is uniform and free of defect such as by heat shock Acceleration : 14,700 m/s ² Period : 0.3 ms. Cycle : 3 times	22	G (0)
3	Deflection			Solder specimens on the testing jig (glass epoxy boards) shown in appended Fig.2 by a Pb free solder. The soldering shall be done either by iron or reflow and be conducted with care so that the soldering is uniform and free of defect such as by heat shock. No damage with 1.6mm deflection	22	G (0)
4	Soldering strength (Push Strength)		DFN0603P2Y 2N Minimum DFN1006P2E , DFN1006P2X 3N Minimum Others 5N Minimum	Solder specimens onto test jig shown below. Apply pushing force at 0.5mm/s until electrode pads are peeled off or product is broken. Pushing force is applied to longitudinal direction. 	22	G (0)
5	Solderability of Termination		95% of the terminations is to be soldered evenly and continuously.	Immerse specimens first an ethanol solution of rosin, then in a Pb free solder solution for 3±0.5 sec. at 245±5 °C. Preheat : 100-120 °C, 60 sec. Solder Paste : Sn-3.0Ag-0.5Cu Flux : Solution of ethanol and rosin (25 % rosin in weight proportion)	22	G (0)
6	Resistance to Soldering Heat (Reflow)	Appearance Electrical specifications	No severe damages Satisfy specifications listed in paragraph 3-2 over operational temperature range	Preheat Temperature : 150-200 °C Preheat Period : 120+/-60 s High Temperature : 217°C High Temp. Period : 105+/-45 s Peak Temperature : 260+0/-5 °C Specimens are soldered twice with the above condition, and then kept in room condition for 24 h before measurements.	22	G (0)

No.	Items		Specifications	Test Methods	Number	Result (Fail)									
7	High Temp. Exposure	Appearance	No severe damages	Temperature : 85+2/-0 °C Period : 1000+48/-0 h Room Condition : 2 ~ 24 h	22	G (0)									
8	Temperature Cycle	Electrical Specifications	Satisfy specifications listed in paragraph 3-2 over operational temperature range	Set the specimens to the supporting jig in the same manner and under the same conditions as Fig.1 and conduct the 100 cycles according to the temperatures and time shown in the following table. Set it for 2 to 24 h at room temperature, then measure.	22	G (0)									
				<table border="1"> <thead> <tr> <th>Step</th> <th>Temp(°C)</th> <th>Time(min)</th> </tr> </thead> <tbody> <tr> <td>1</td> <td>Min. Operating Temp.+0/-3</td> <td>30±3</td> </tr> <tr> <td>2</td> <td>Max. Operating Temp.+3/-0</td> <td>30±3</td> </tr> </tbody> </table>			Step	Temp(°C)	Time(min)	1	Min. Operating Temp.+0/-3	30±3	2	Max. Operating Temp.+3/-0	30±3
Step	Temp(°C)			Time(min)											
1	Min. Operating Temp.+0/-3			30±3											
2	Max. Operating Temp.+3/-0	30±3													
		Temperature: 85±2 °C Humidity: 80~90 %RH Period: 1000+48/-0 h Room Condition: 2 ~ 24 h													
		Temperature: -40±2 °C Period: 1000+48/-0 h Room Condition: 2 ~ 24 h													
9	Humidity (Steady State)			Temperature: 85±2 °C Humidity: 80~90 %RH Period: 1000+48/-0 h Room Condition: 2 ~ 24 h	22	G (0)									
10	Low Temp. Exposure			Temperature: -40±2 °C Period: 1000+48/-0 h Room Condition: 2 ~ 24 h	22	G (0)									

Fig. 1 Land Pattern

Package : DFN1006P2E , DFN1006P2X

Unit : mm

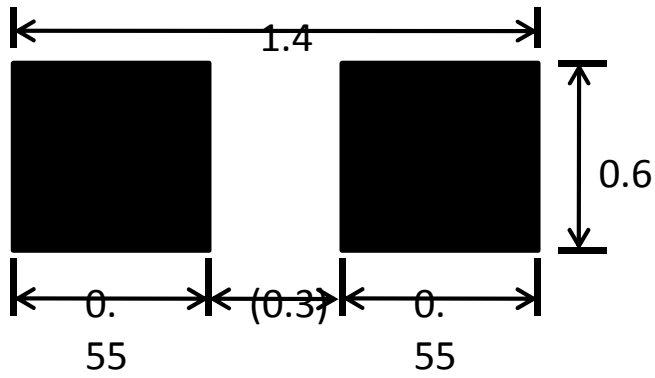

※Reference purpose only.

Package : QFN1616P6E

Unit : mm

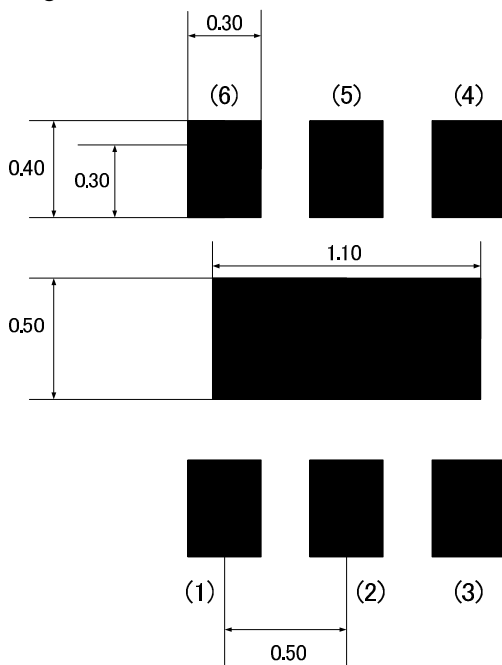

※Reference purpose only.

Package : SOT23-6L

Unit : mm

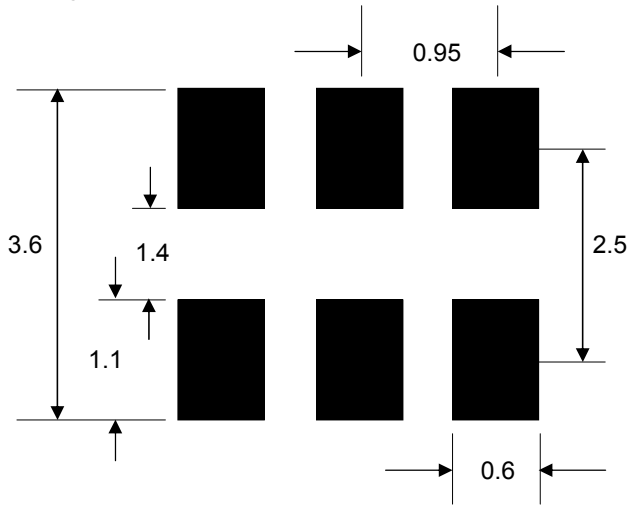

※Reference purpose only.

Package : SOT23-5L

Unit : mm

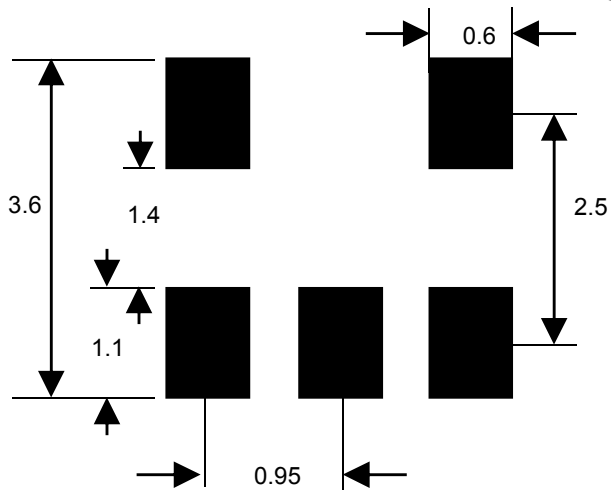

※Reference purpose only.

Package : DFN2510P10E

Unit : mm

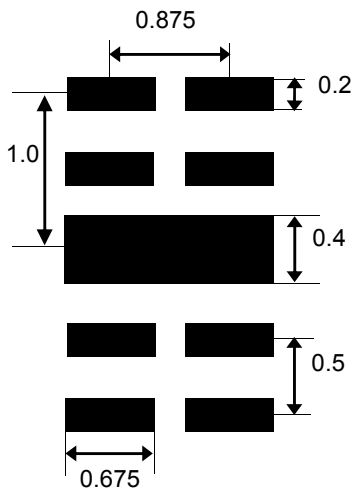

※Reference purpose only.

Package : MSOP-8L

Unit : mm

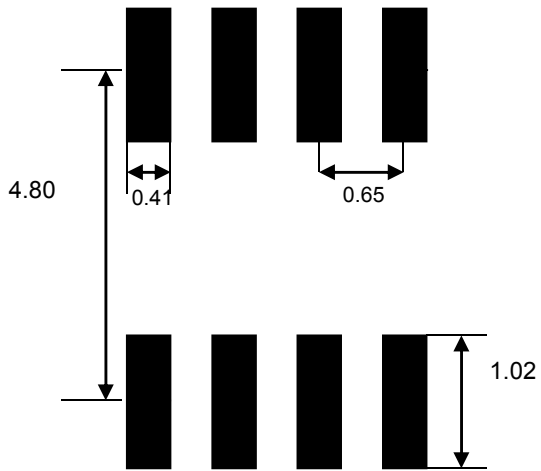

※Reference purpose only.

Package :DFN4120P10E

単位 : mm

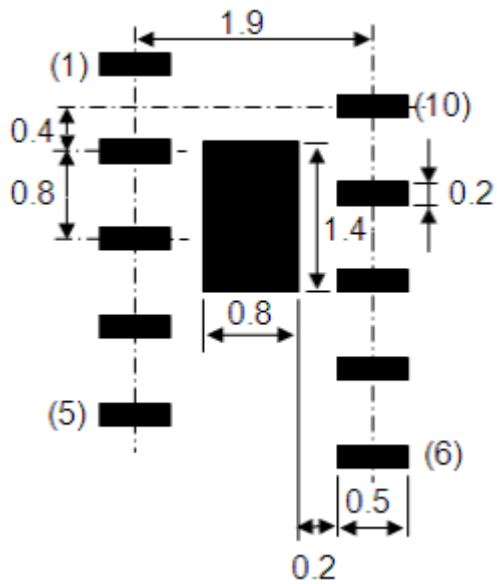

※Reference purpose only.

Fig. 2 Testing board

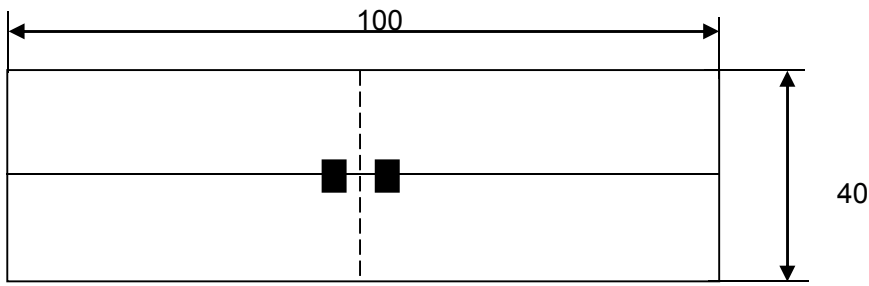

(Unit : mm)

■ Land
Land pattern is same as figure 1
Glass-fluorine board $t=1.6\text{mm}$
Copper thickness over $35\ \mu\text{m}$

Mounted situation

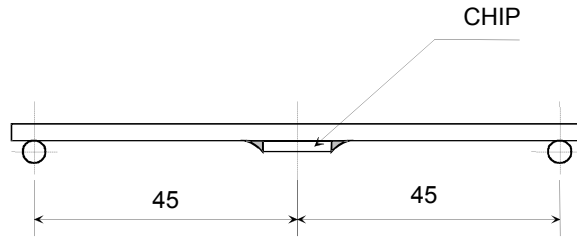

(Unit : mm)

Test method

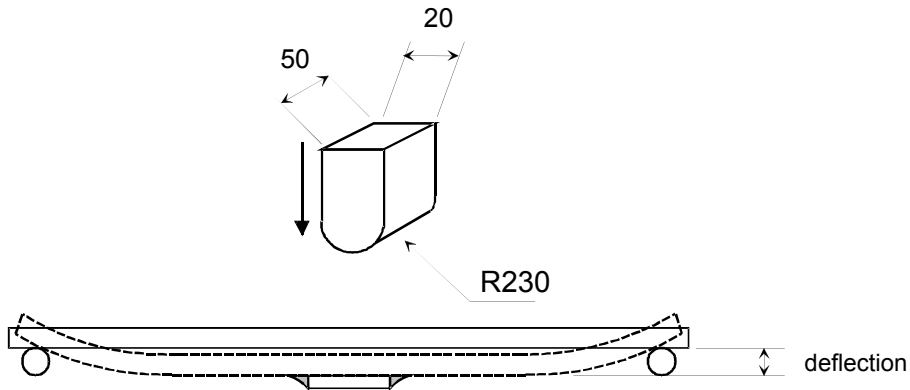

(Unit : mm)

6. Tape and Reel Packing

(1) Dimensions of Tape (Plastic tape)

Not in scale

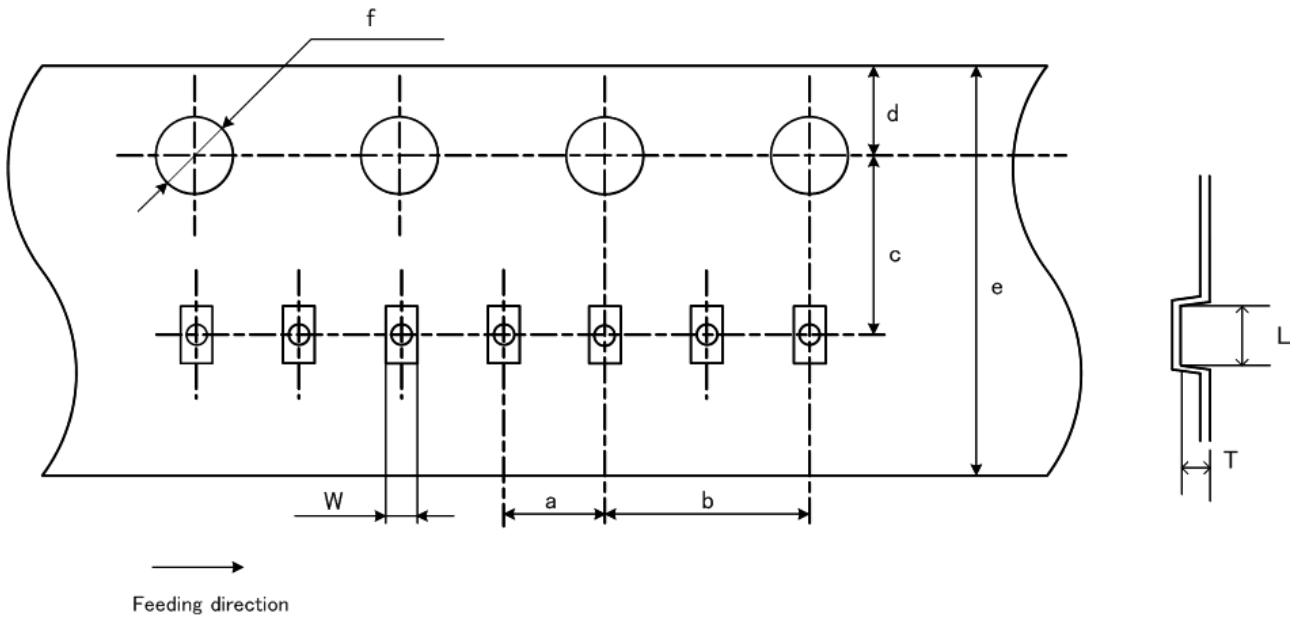

Unit : mm

package	DFN1006P2E	DFN1006P2X
L	(1.10)	(1.15)
W	(0.70)	(0.70)
T	(0.65)	(0.52)
a	2.00+/-0.05	2.00+/-0.05
b	4.00+/-0.10	4.00+/-0.10
c	3.50+/-0.05	3.50+/-0.05
d	1.75+/-0.1	1.75+/-0.1
e	8.00+0.30/-0.10	8.00+/-0.10
f	φ1.55+/-0.05	φ1.55+/-0.05

(2) Dimensions of Tape (Plastic tape)

Not in scale

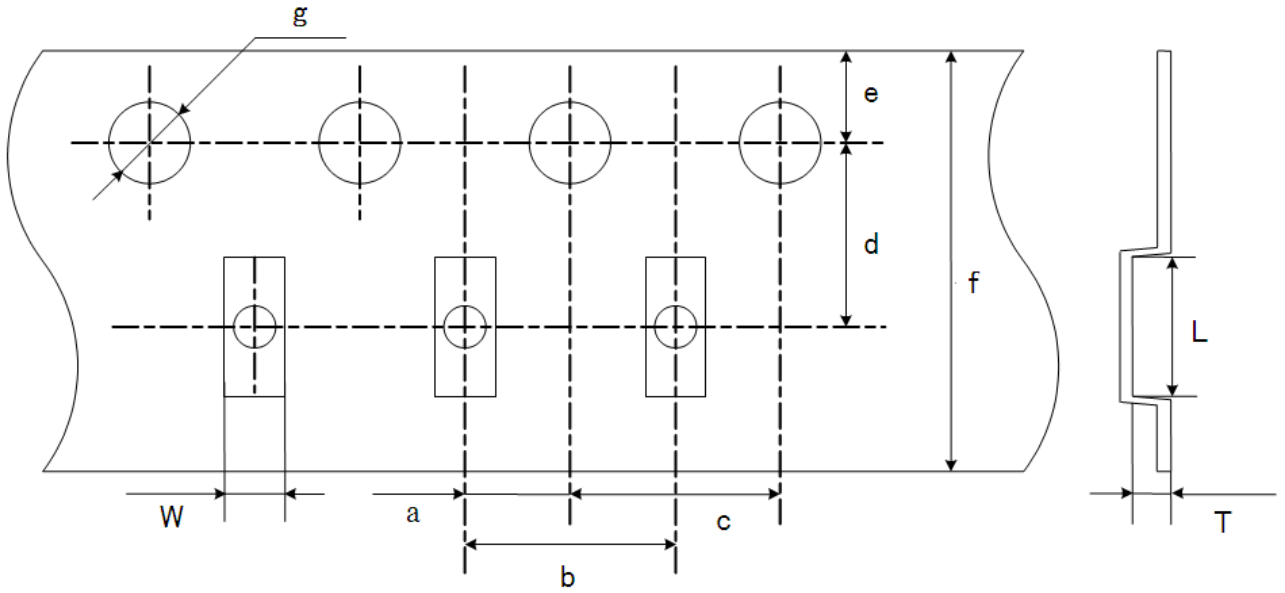

Unit : mm

package	QFN1616P6E	SOT23-6L	SOT23-5L	DFN2510P10E	MSOP-8L	DFN4120P10E
L	1.80+/-0.05	3.23+/-0.10	3.23+/-0.10	2.70+/-0.05	3.40+/-0.10	4.22+0.05/-0.04
W	1.80+/-0.05	3.17+/-0.10	3.17+/-0.10	1.23+/-0.05	5.30+/-0.10	2.21+/-0.05
T	0.69+/-0.05	1.37+/-0.10	1.37+/-0.10	0.70+/-0.05	1.40+/-0.10	0.81+/-0.05
a	2.00+/-0.05	2.00+/-0.05	2.00+/-0.05	2.00+/-0.05	2.00+/-0.05	2.00+/-0.05
b	4.00+/-0.10	4.00+/-0.10	4.00+/-0.20	4.00+/-0.10	8.00+/-0.10	4.00+/-0.10
c	4.00+/-0.10	4.00+/-0.10	4.00+/-0.10	4.00+/-0.10	4.00+/-0.10	4.00+/-0.10
d	3.50+/-0.05	3.50+/-0.05	3.50+/-0.05	3.50+/-0.05	5.50+/-0.05	5.50+/-0.05
e	1.75+/-0.1	1.75+/-0.1	1.75+/-0.1	1.75+/-0.1	1.75+/-0.10	1.75+/-0.1
f	8.00+/-0.10	8.00+0.30/-0.10	8.00+0.30/-0.10	8.00+0.30/-0.20	12.0+/-0.30	12.0+0.30/-0.10
g	φ1.55+/-0.05	φ1.55+/-0.05	φ1.55+/-0.05	φ1.55+/-0.05	φ1.55+/-0.05	φ1.55+/-0.05

(3) Dimensions of Reel

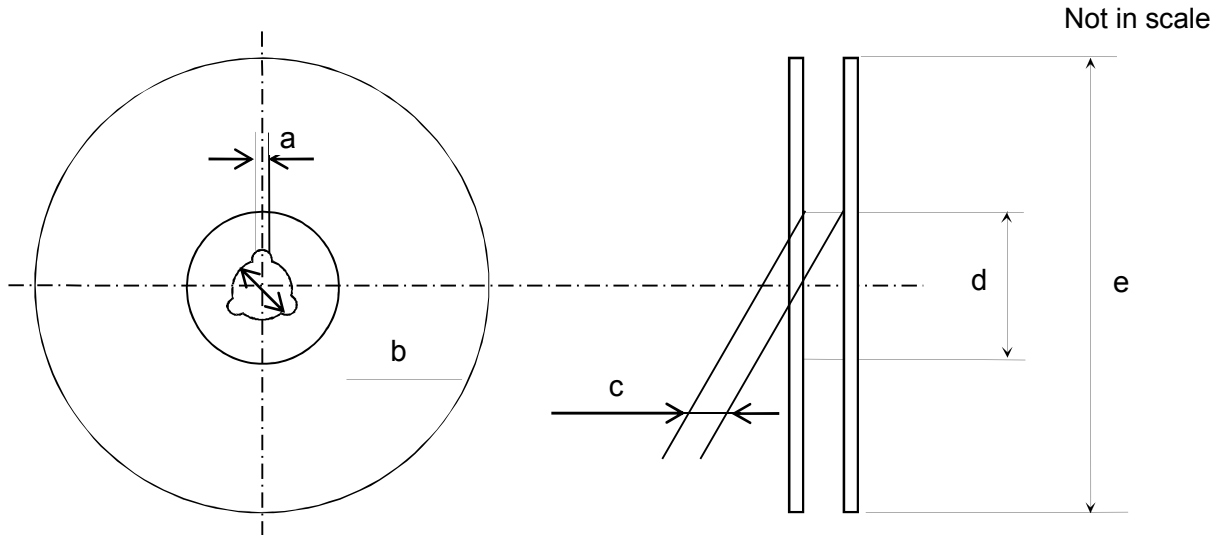

Unit : mm

package	DFN1006P2E	DFN1006P2X	QFN1616P6E	SOT23-6L
a	1.5 min	1.5 min	2.3+/-0.1	2.3+/-0.1
b	φ13.0+/-0.2	φ13.0+/-0.2	φ13.0+/-0.2	φ13.0+/-0.2
c	9.2+2.0/-0	9.2+2.0/-0	9.5+/-1.0	9.5+/-1.0
d	φ60	φ60	φ54.4	φ60
e	φ180	φ180	φ180	φ180

package	SOT23-5L	DFN2510P10E	MSOP-8L	DFN4120P10E
a	2.0+0.5/-0	2.3+/-0.1	2.0+/-0.5	1.9+/-0.15
b	φ13.0+0.5/-0.3	φ13.0+/-0.2	φ13.0+0.5/-0.2	φ13.0
c	8.6+1.0/-0	9.5+/-0.2	12.8+0.3/-0.2	13.2+/-0.2
d	φ54.4	φ60	φ100	φ60
e	φ180	φ180	φ330	φ180

(4) PACKAGE Diagrams (Humidity proof Packing)

Tape and reel must be sealed with the anti-humidity plastic bag. The bag contains the desiccant and the humidity indicator.

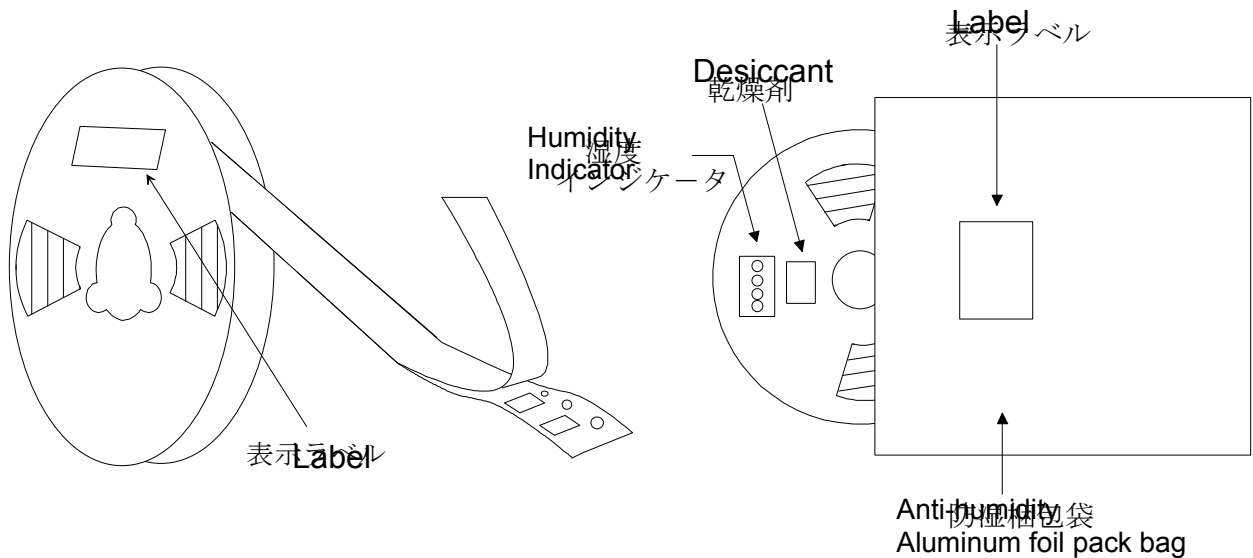

(5) Taping Diagrams

- [1] Feeding Hole : As specified in (1),(2)
- [2] Hole for chip : As specified in (1),(2)
- [3] Cover tape : 50 μ m in thickness
- [4] Base tape : As specified in (1),(2)

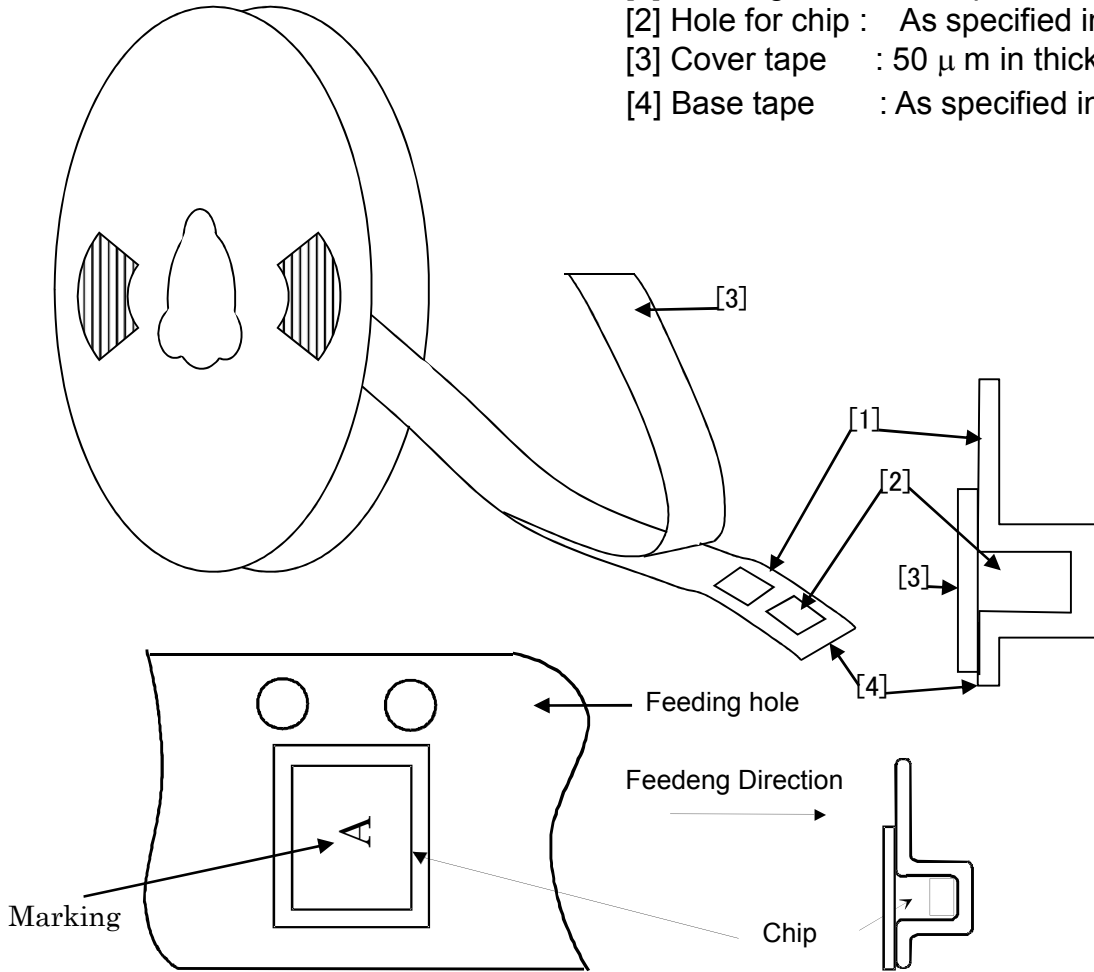

Marking Direction

LXES1UBAB1-007

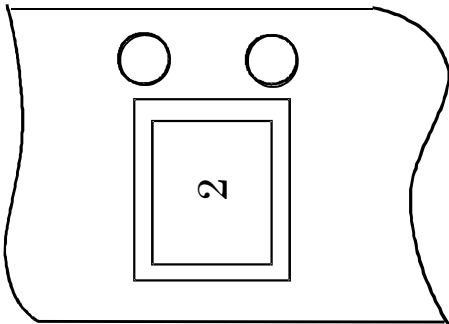

LXES1UBAA1-096

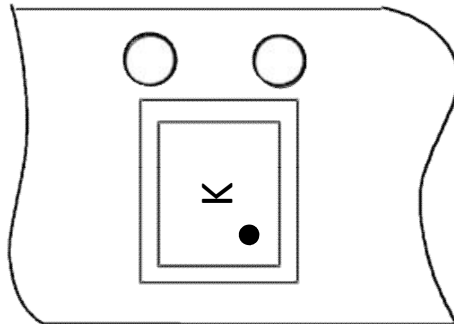

LXES1TBCC2-004/LXES1TBBB2-013

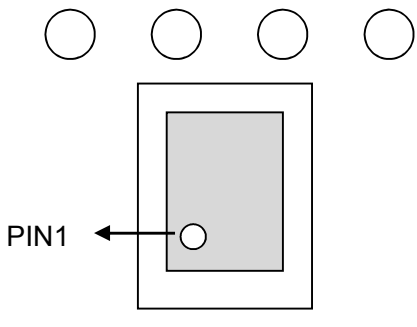

LXES2SBAA4-016/LXES2SBBB4-026

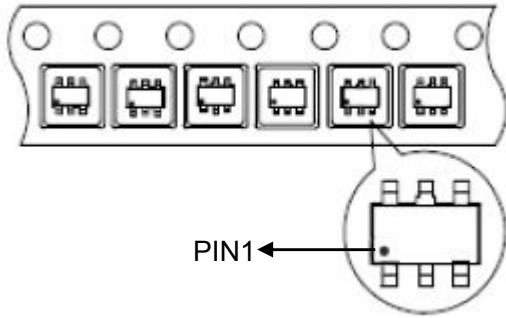

LXES4XBAA6-027/ LXES2TBCC4-028/
LXESEABAA6-046

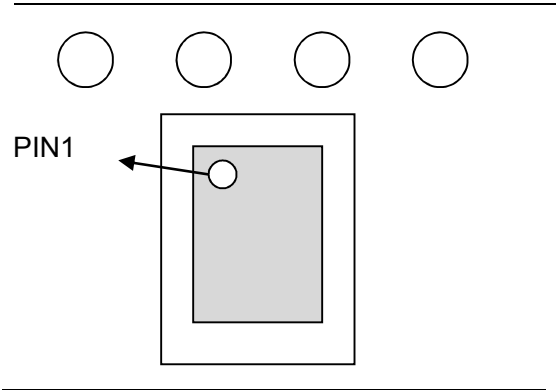

LXES2SBAA4-114

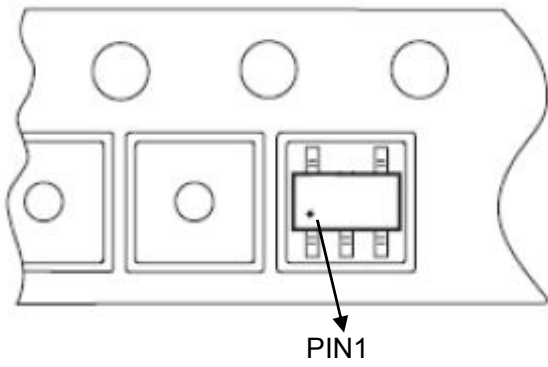

(6) Leader and Tail tape

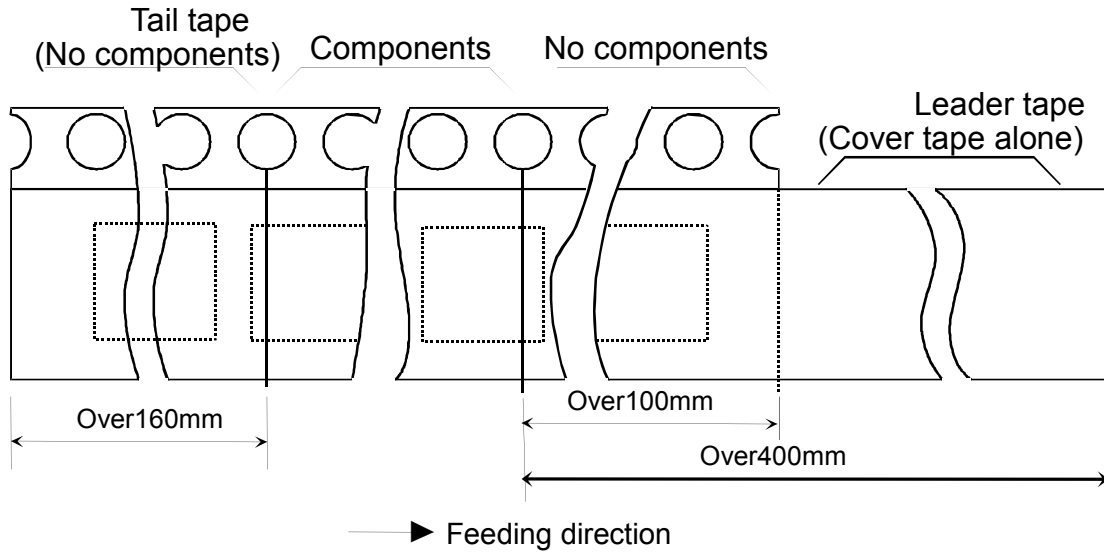

(7) The tape for chips are wound clockwise, the feeding holes to the right side as the tape is pulled toward the user.

(8) Packaging unit:

Unit : pcs / reel

package	DFN1006P2E	DFN1006P2X	QFN1616P6E	SOT23-6L
quantity	3000	12000	3000	3000

package	SOT23-5L	DFN2510P10E	MSOP-8L	DFN4120P10E
quantity	3000	3000	3000	3000

(9) Material : Base tape Plastic
 ReelPlastic

Base tape, Reel and Top tape have an anti-ESD function.

(10) Peeling of force : 0.1~1.0 N in the direction of peeling as shown below.

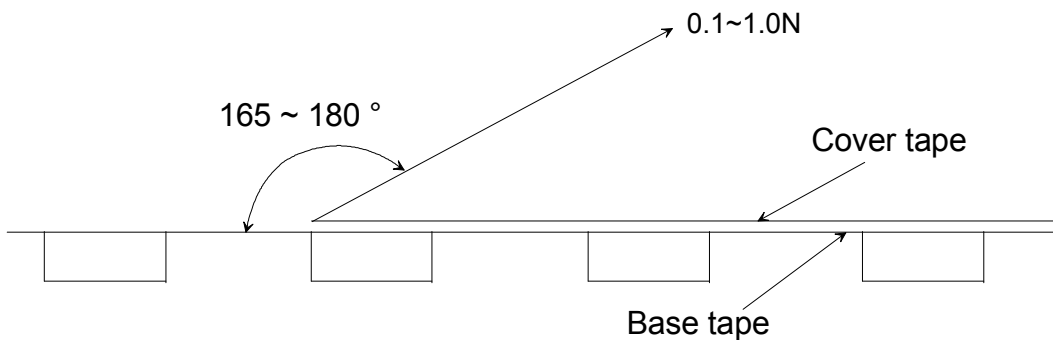

NOTICE

1. Storage Conditions:

- The product shall be stored without opening the packing under the ambient temperature from 5 to 35 deg.C and humidity from 20 to 70%RH.
(Packing materials, in particular, may be deformed at the temperature over 40 deg.C.)
- The product left more than 6 months after reception, it needs to be confirmed the solderability before used.
 - The product shall be stored in non corrosive gas (Cl₂, NH₃, SO₂, NO_x, etc.).
 - Any excess mechanical shock including, but not limited to, sticking the packing materials by sharp object and dropping the product, shall not be applied in order not to damage the packing materials.
- After the packing opened, the product shall be stored at ≤ 30 deg.C / ≤ 60 %RH and the product shall be used within 168 hours.

When the color of the indicator in the packing changed, the product shall be baked before soldering.

This product is applicable to MSL3 (Based on IPC/JEDEC J-STD-020)

2. Handling Conditions:

Be careful in handling or transporting products because excessive stress or mechanical shock may break products.

Handle with care if products may have cracks or damages on their terminals, the characteristics of products may change. Do not touch products with bare hands that may result in poor solderability.

3. Standard PCB Design (Land Pattern and Dimensions):

All the ground terminals should be connected to the ground patterns. Furthermore, the ground pattern should be provided between IN and OUT terminals. Please refer to the specifications for the standard land dimensions.

The recommended land pattern and dimensions is as Murata's standard. The characteristics of products may vary depending on the pattern drawing method, grounding method, land dimensions, land forming method of the NC terminals and the PCB material and thickness. Therefore, be sure to verify the characteristics in the actual set. When using non-standard lands, contact Murata beforehand.

4. Notice for Chip Placer:

When placing products on the PCB, products may be stressed and broken by uneven forces from a worn-out chucking locating claw or a suction nozzle. To prevent products from damages, be sure to follow the specifications for the maintenance of the chip placer being used. For the positioning of products on the PCB, be aware that mechanical chucking may damage products.

5. Soldering Conditions:

Carefully perform preheating so that the temperature difference (ΔT) between the solder and products surface should be in the following range. When products are immersed in solvent after mounting, pay special attention to maintain the temperature difference within 100 °C. Soldering must be carried out by the above mentioned conditions to prevent products from damage. Contact Murata before use if concerning other soldering conditions.

Soldering method	Temperature
Soldering iron method	$\Delta T \leq 130 \text{ }^\circ\text{C}$
Reflow method	

- Soldering iron method conditions are indicated below.

Kind of iron Item	heater
Soldering iron wattage	$\leq 18 \text{ W}$
Temperature of iron-tip	$\leq 350 \text{ }^\circ\text{C}$
Iron contact time	within 3 s

- Diameter of iron-tip : $\phi 3.0 \text{ mm max.}$
- Do not allow the iron-tip to directly touch the mold resin.

Reflow soldering standard conditions (Example)

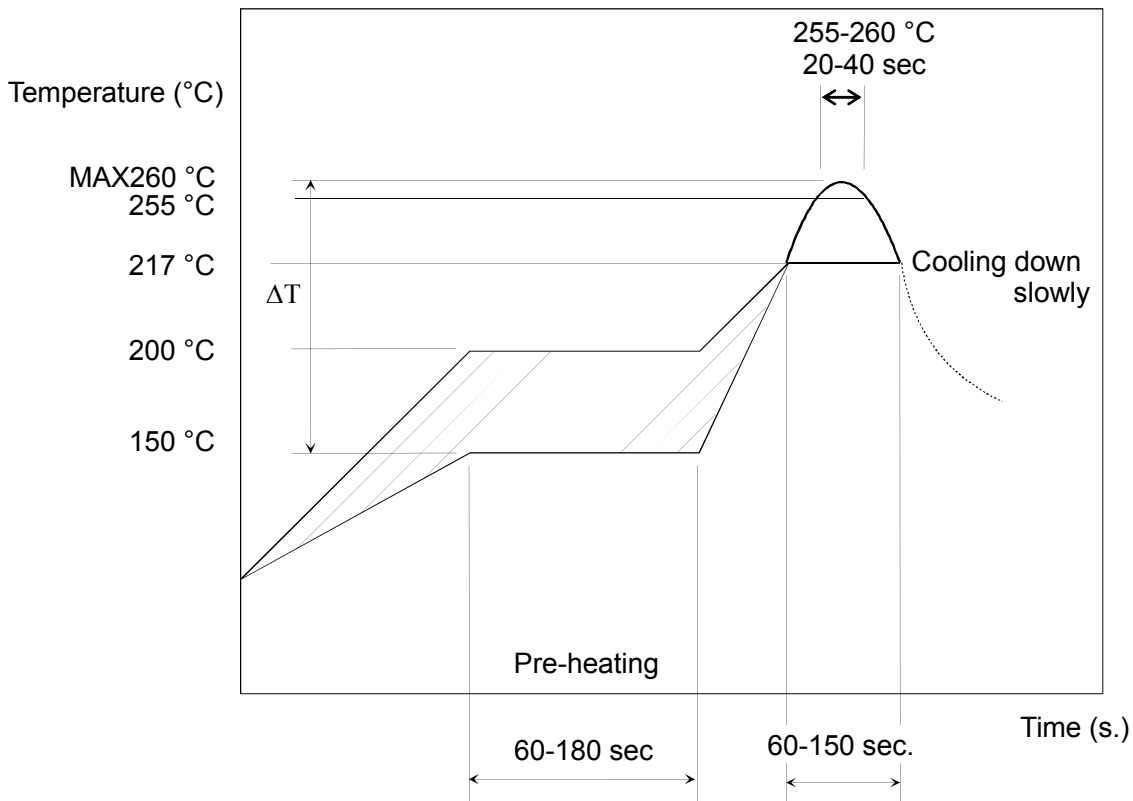

Use rosin type flux or weakly active flux with a chlorine content of 0.2 wt % or less.

Amount of Solder Paste:

- Ensure that solder is applied smoothly to a minimum height of 0.2 to 0.5 mm at the end surface of the external electrodes. If too much or little solder is applied, there is high possibility that the mechanical strength will be insufficient, creating the variation of characteristics.

Amount of solder paste

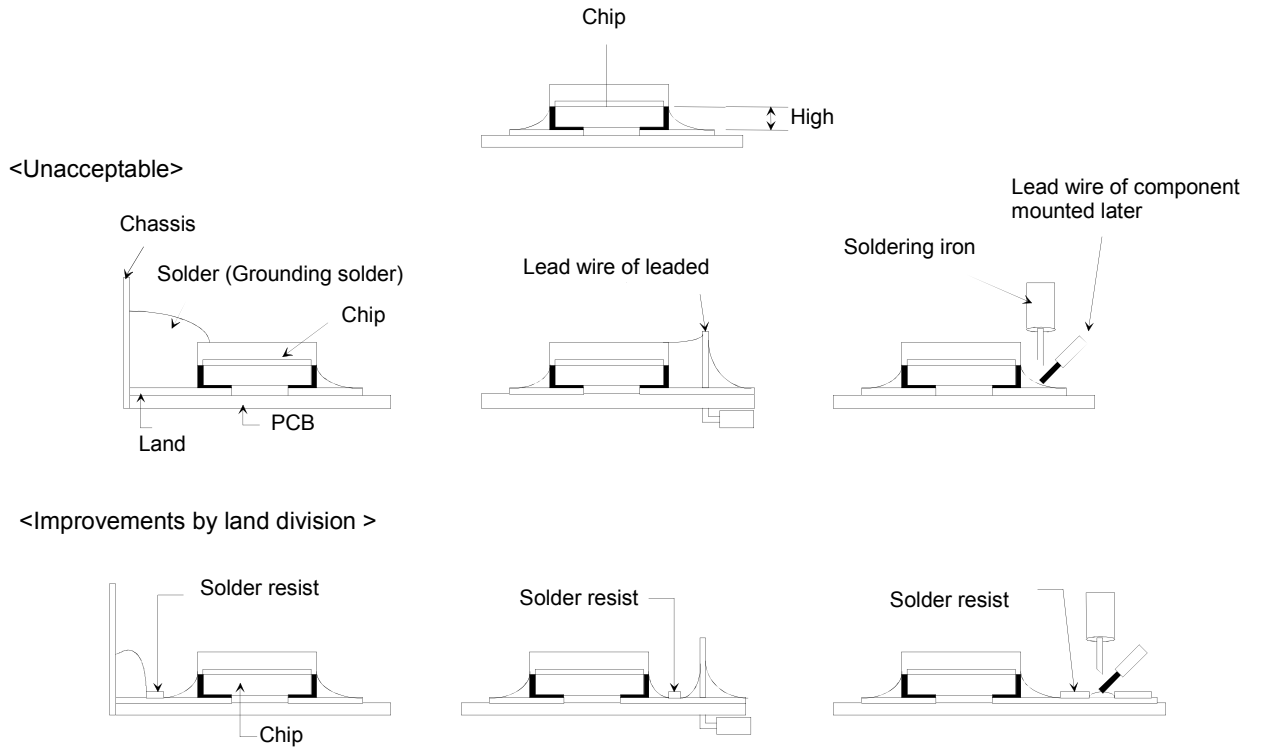

6. Cleaning Conditions:

Any cleaning is not permitted.

7. Operational Environment Conditions:

Products are designed to work for electronic products under normal environmental conditions (ambient temperature, humidity and pressure). Therefore, products have no problems to be used under the similar conditions to the above-mentioned. However, if products are used under the following circumstances, it may damage products and leakage of electricity and abnormal temperature may occur.

- In an atmosphere containing corrosive gas (Cl₂, NH₃, SO_x, NO_x etc.).
- In an atmosphere containing combustible and volatile gases.
- In a dusty environment.
- Direct sunlight
- Water splashing place.
- Humid place where water condenses.
- In a freezing environment.

If there are possibilities for products to be used under the preceding clause, consult with Murata before actual use.

If product malfunctions may result in serious damage, including that to human life, sufficient fail-safe measures must be taken, including the following:

- (1) Installation of protection circuits or other protective device to improve system safety
- (2) Installation of redundant circuits in the case of single-circuit failure

8. Limitation of Applications:

The products are designed and produced for application in ordinary electronic equipment (AV equipment, OA equipment, telecommunication, etc). If the products are to be used in devices requiring extremely high reliability following the application listed below, you should consult with the Murata staff in advance.

- Aircraft equipment.
- Aerospace equipment
- Undersea equipment.
- Power plant control equipment.
- Medical equipment.
- Transportation equipment (vehicles, trains, ships, etc.).
- Traffic signal equipment.
- Disaster prevention / crime prevention equipment.
- Data-processing equipment.
- Application which malfunction or operational error may endanger human life and property of assets.
- Application which related to occurrence the serious damage
- Application of similar complexity and/ or reliability requirements to the applications listed in the above.

 **Note:**

Please make sure that your product has been evaluated and confirmed against your specifications when our product is mounted to your product.

Product specifications are subject to change or our products in it may be discontinued without advance notice.

This catalog is for reference only and not an official product specification document, therefore, please review and approve our official product specification before ordering this product.

Note:

This catalog is for reference only and not an official product specification document, therefore, please review and approve our official product specification before ordering this product.

X-ON Electronics

Largest Supplier of Electrical and Electronic Components

Click to view similar products for [ESD Suppressors / TVS Diodes](#) category:

Click to view products by [Murata](#) manufacturer:

Other Similar products are found below :

[60KS200C](#) [D12V0H1U2WS-7](#) [D18V0L1B2LP-7B](#) [82356050220](#) [D5V0M5U6V-7](#) [NTE4902](#) [P4KE27CA](#) [P6KE11CA](#) [P6KE39CA-TP](#)
[P6KE8.2A](#) [SA110CA](#) [SA60CA](#) [SA64CA](#) [SMBJ12CATR](#) [SMBJ8.0A](#) [SMLJ30CA-TP](#) [ESD101-B1-02ELS E6327](#) [ESD112-B1-02EL E6327](#)
[ESD119B1W01005E6327XTSA1](#) [ESD5V0J4-TP](#) [ESD5V0L1B02VH6327XTSA1](#) [ESD7451N2T5G](#) [19180-510](#) [CPDT-5V0USP-HF](#)
[3.0SMCJ33CA-F](#) [3.0SMCJ36A-F](#) [HSPC16701B02TP](#) [D3V3Q1B2DLP3-7](#) [D55V0M1B2WS-7](#) [DESD5V0U1BL-7B](#) [DRTR5V0U4SL-7](#)
[SCM1293A-04SO](#) [ESD200-B1-CSP0201 E6327](#) [ESD203-B1-02EL E6327](#) [SM12-7](#) [SMF8.0A-TP](#) [SMLJ45CA-TP](#) [CEN955 W/DATA](#)
[82350120560](#) [82356240030](#) [VESD12A1A-HD1-GS08](#) [CPDUR5V0R-HF](#) [CPDUR24V-HF](#) [CPDQC5V0U-HF](#) [CPDQC5V0USP-HF](#)
[CPDQC5V0-HF](#) [D1213A-01LP4-7B](#) [D1213A-02WL-7](#) [ESDLIN1524BJ-HQ](#) [5KP100A](#)