

UHF RFID Tag Data sheet

LXTBKZMCMG-010



1. General Descriptions

LXTBKZMCMG-010 is an innovative RFID module which complies EPC global Gen2 (v2).

This product can be used as an ultra small tag and this can be fit on any metal objects.

This can be used globally with high performance and reliability.

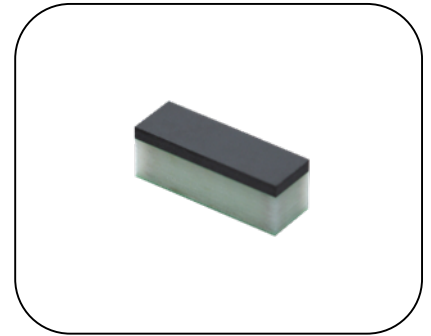

[Features]

- Small package design
- UHF band (865~928MHz)
- ISO18000-63 / EPC Global Gen2(v2) Compliant
- Size is 6.0 x 2.0 x 2.3mm
- Using Impinj MonzaR6P
- Read range: Up to 150cm on metal (4WEIRP) *Reference
- RoHS compliant

2. Block Diagram

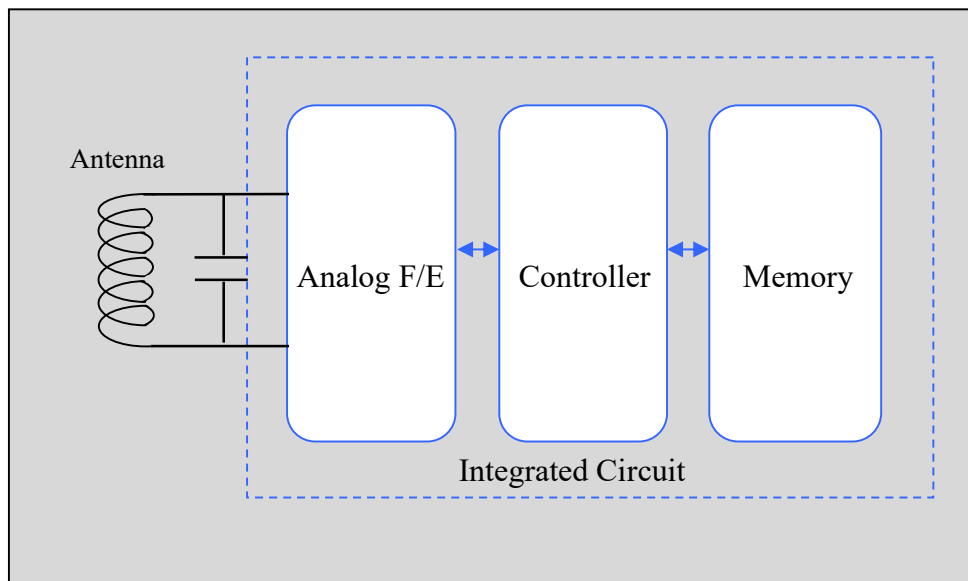

3. Mechanical Information

[Dimension]

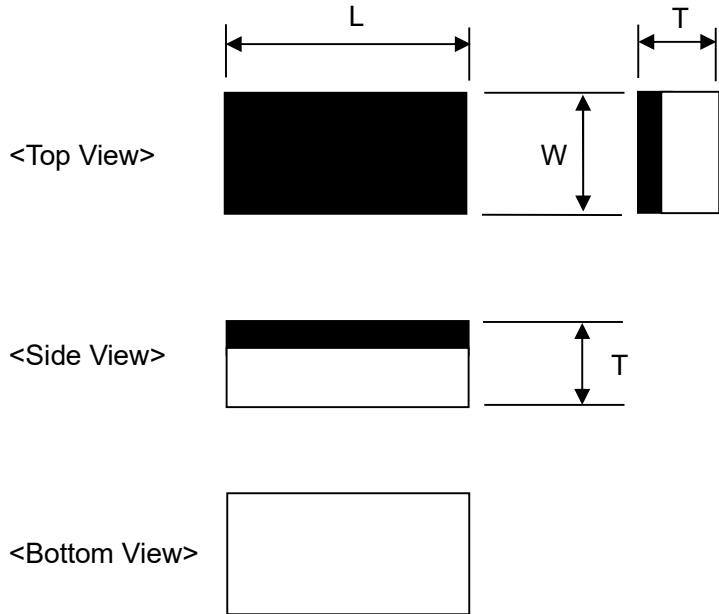

Unit:mm

Mark	Dimensions
L	6.0±0.20
W	2.0±0.20
T	2.3 Max

4. Electrical Performance

4-1. Frequency range

865-928MHz

4-2. IC / Memory size

Parameter		Description	Remarks
IC		Impinj Monza R6P	
Protocol		ISO/IEC 18000-63	
		EPC global Gen2 V2	
Memory *1	EPC	Default Memory Profile : 128 bit Max User Memory Profile : 96bit	Read & Write
	TID	96 bit	Read Only
	Reserved memory	64 bit	
	User	Default Memory Profile : 32 bit Max User Memory Profile : 64bit	
Data retention Time		50years *	Tamb = 22°C

*Reference value

5. Reading range (reference only)

Read range varies depending on use case and hardware.

UHF band(865~928MHz) : Up to 150cm on metal (4WEIRP)

6. Absolute maximum ratings

Symbol	Parameter	Min	Max	Unit
T _{stg}	Storage temperature	-40	+85	°C
T _{amb}	Operating temperature	-40	+85	°C

7. Packaging

7-1. Dimensions of tape

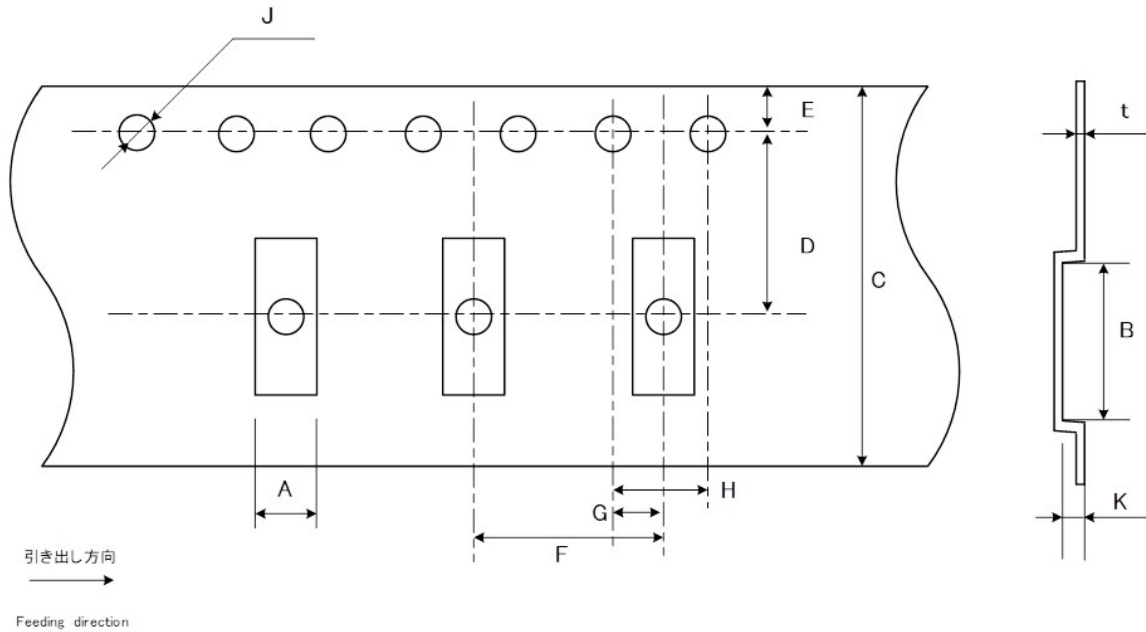

Unit: mm

Symbol	A	B	C	D	E	F
Dimension	2.6±0.1	6.6±0.1	16.0 +0.2	7.5±0.1	1.75±0.1	8.0±0.1

Symbol	G	H	J	K	t
Dimension	2.0±0.1	4.0±0.1	1.5 +0.1-0	2.35±0.05	0.30±0.05

7-2. Dimensions of reel

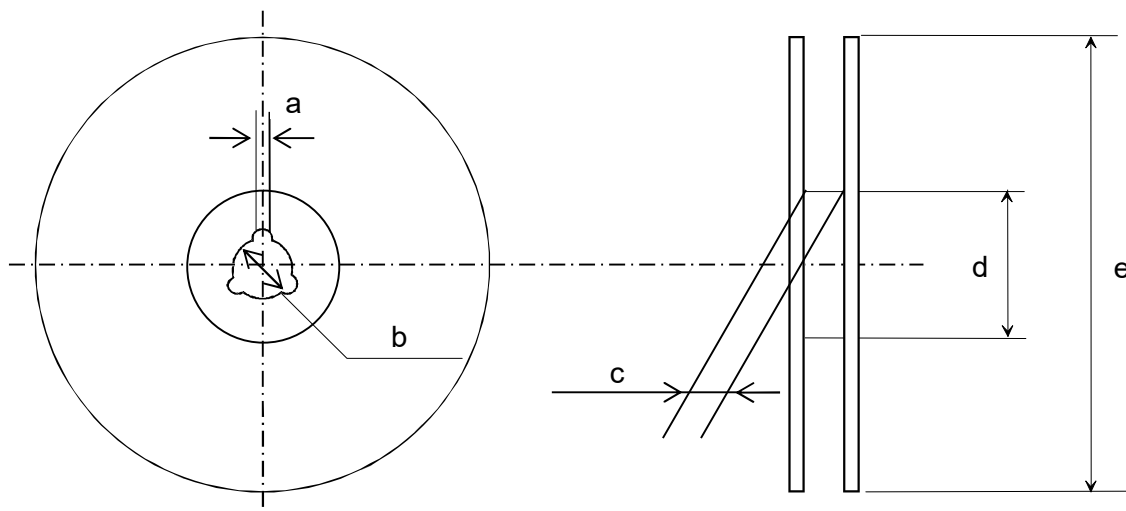

Unit: mm

Symbol	a	b	c	d	e
Dimension	2.0+/-0.5	Φ13.0+/-0.2	17.4+/-1.0	(Φ100)	(Φ330)

All Rights Reserved, Copyright© Murata Manufacturing Co., Ltd.

< Specification is subject to change without notice >

7-3. Taping Diagrams

- [1] Feeding Hole : As specified in 7-1
- [2] Hole for chip : As specified in 7-1
- [3] Cover tape : 50um in thickness
- [4] Base tape : As specified in 7-1

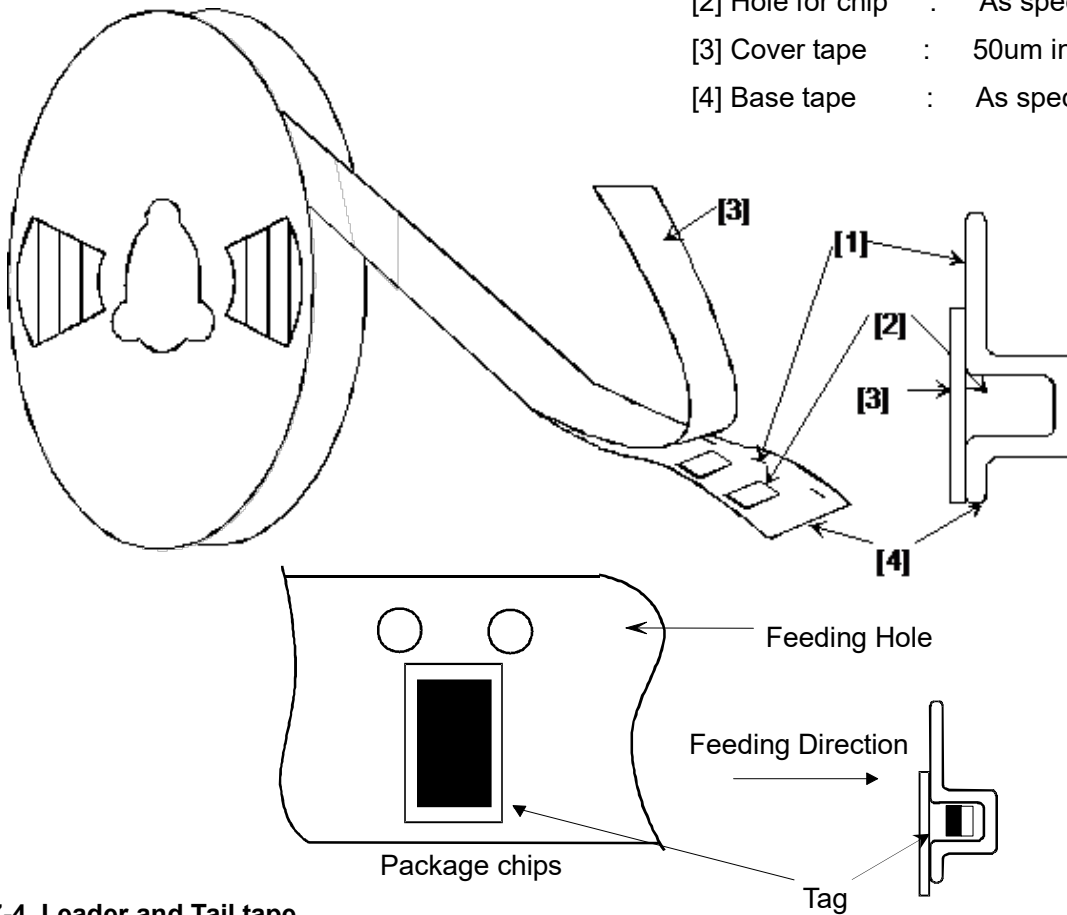

7-4. Leader and Tail tape

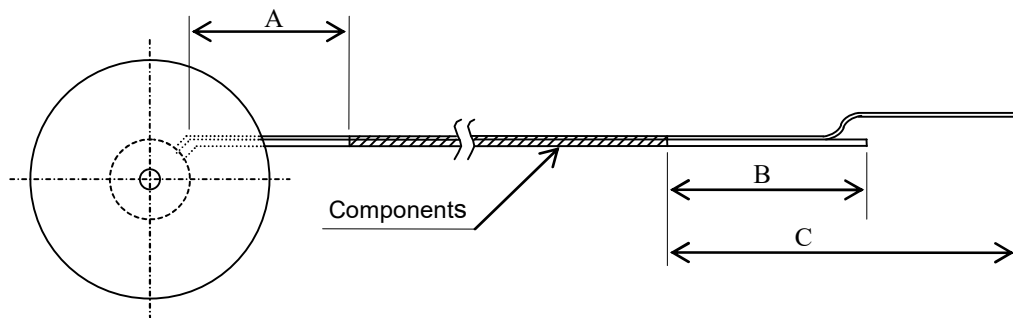

Unit : mm

Symbol	Item	Minimum length
A	Tail	160
B	Leader no components	100
C	Leader with cover tape	400

7-5. Taping direction

The tape for chips are wound clockwise.

The feeding holes will come on the right side when the tape is pulled to a user's direction.

7-6. Quantity per reel

2,000 pcs

7-7. Minimum order quantity

2,000pcs

7-8. Material

Base and Cover tape : Plastic

Reel : Plastic

Base and Cover tape, Reel have an anti-ESD function.

7-9. Peeling strength

0.1-1.3N when peeled in the direction below.

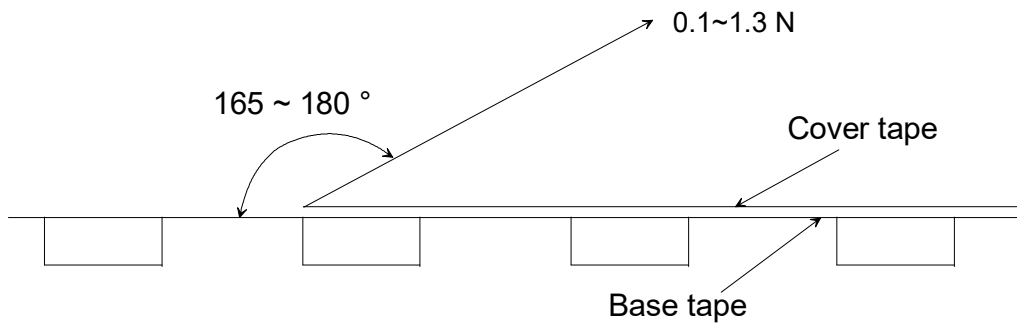

8. Contact window

URL: <http://www.murata.com/products/rfid>

Email: magicstrap@murata.com

For any inquiries/queries, please feel free to contact us.

NOTICE

1. Storage Conditions:

To avoid damaging, be sure to observe the following points.

- Store products where the ambient temperature is 15 to 35 °C and humidity 45 to 75% RH.
(Packing materials, In particular, may be deformed at the temperature over 40 °C.).
- Store products in non corrosive gas (Cl₂, NH₃, SO₂, NO_x, etc.).
- Stored products should be used within 6 months of receipt.

2. Handling Conditions:

Be careful in handling or transporting products because excessive stress or mechanical shock may break products.

3. Operational Environment Conditions:

Products are designed to work under normal environmental conditions (ambient temperature, humidity and pressure). Therefore, products have no problems to be used under the similar conditions to the above-mentioned. However, if products are used under the following circumstances, it may damage products and leakage of electricity and abnormal temperature may occur.

- In an atmosphere containing corrosive gas (Cl₂, NH₃, SO_x, NO_x etc.).F
- In an atmosphere containing combustible and volatile gases.
- In a dusty environment.
- Direct sunlight
- Water splashing place.
- Humid place where water condenses.
- In a freezing environment.

If there are possibilities for products to be used under the preceding clause, consult with Murata before actual use.

If static electricity is added to this product, degradation and destruction may be produced.

Please use it after consideration enough so that neither static electricity nor excess voltage is added at the time of an assembly and measurement.

If product malfunctions may result in serious damage, including that to human life, alternative measures of the operation and design must be taken to secure the safety.

All Rights Reserved, Copyright© Murata Manufacturing Co., Ltd.

< Specification is subject to change without notice >

4. Cleaning Conditions:

If the cleaning will be applied, please check with Murata in advance since the product may degrade or get broken.

5. Limitation of Applications:

Please contact us before using our products for the applications listed below which require especially high reliability for the prevention of defects which might directly cause damage to the third party's life, body or property.

- (1) Aircraft equipment
- (2) Aerospace equipment
- (3) Undersea equipment
- (4) Power plant control equipment
- (5) Medical equipment
- (6) Transportation equipment (vehicles, trains, ships, etc.)
- (7) Traffic signal equipment
- (8) Disaster prevention / crime prevention equipment
- (9) Data-processing equipment
- (10) Application of similar complexity and/or reliability requirements to the application listed in the above.



Note:

Please make sure that your product has been evaluated and confirmed against your specifications when our product is attached to your product.

All the items and parameters in this product specification have been prescribed on the premise that our product is used for the purpose, under the condition and in the environment agreed upon between you and us. You are requested not to use our product deviating from such agreement.

X-ON Electronics

Largest Supplier of Electrical and Electronic Components

Click to view similar products for [NFC/RFID Tags & Transponders](#) category:

Click to view products by [Murata](#) manufacturer:

Other Similar products are found below :

[PCF7941ATSM2AB120](#), [PNEV512B,699](#) [V680-D1KP54T](#) [V680S-A40 50M](#) [PN7120A0EV/C10801Y](#) [TRPGR30ATGA](#) [SPS1M003B](#)
[SPS1M003A](#) [SPS1M002B](#) [SPS1M002A](#) [V680S-A40 10M](#) [V680-D1KP66T](#) [ATA5577M2330C-DBQ](#) [SL2S5302FTBX](#) [LXMSJZNCMD-217](#)
[60208](#) [60170](#) [P5DF081X0/T1AD2060](#) [MF1S5030XDA8/V1J](#) [MF1S7030XDA4/V1J](#) [HT1MOA4S30/E/3J](#) [HT2MOA4S20/E/3/RJ](#)
[MFRC52302HN1,157](#) [TRPGR30ATGB](#) [NRF51822-QFAA-R](#) [20926410601](#) [CLRC66303HNE](#) [ART915X1620TX16-IC](#)
[ART915X2117225TX21-IC](#) [28448](#) [ART923X1015YZ10-IC](#) [ART868X130903TX13](#) [ART868X25275YZ25](#) [ART915X050503OP-IC](#)
[ART915X100202TO-IC](#) [ART915X100503JA-IC](#) [ART915X130930TX13-IC](#) [ART915X250903AM-IC](#) [ART915X2509EP60-IC](#)
[ART915X252503MA-IC](#) [ART915X25275YZ25](#) [ART915X25275YZ25-IC](#) [ART923X1015YZ10](#) [AS3932-BTST](#) [AS3933-BTST](#)
[20926410802](#) [LXMSJZNCMF-198](#) [MIKROE-779](#) [13356-0571](#) [13356-1151](#)