

Typical unit

FEATURES

- High efficiency (95% @12Vin, 3.3Vout)
- Power Block (60A, 7-13.2Vin, 0.6-3.63Vout, SMT)
- Input under-voltage lockout
- Small footprint (1" [25.4] x 0.5" [12.7] x 0.48" [12.2])
- No minimum load required
- Low Output Ripple
- -40°C to +85°C operating temperature
- Two phases

PRODUCT OVERVIEW

The "60A Power Block" is an 115.5W, non-isolated DC-DC converter. This DC-DC module is a structure block for a new open digital power design developed to work with either digital or analog controllers, with an input range of 7-13.2VDC and a regulated output of 0.6-3.63VDC, with load current up to 60A at 0.6V to 1.32V output voltage. The Power Block is a synchronous buck converter. The two phases can be tied together and can current share as a single output, or they can be separated

as two different outputs. It has been implemented using a synchronous buck gate driver IC with co-packed control and synchronous MOSFETs and Schottky diode. The output filter consists of 270nH inductance and 10µF capacitance. A Low Drop out Voltage Regulator is used to provide regulated 7V VCC to the gate driver IC. A Voltage Detector is used to shut down the gate driver when VCC drops below limit.

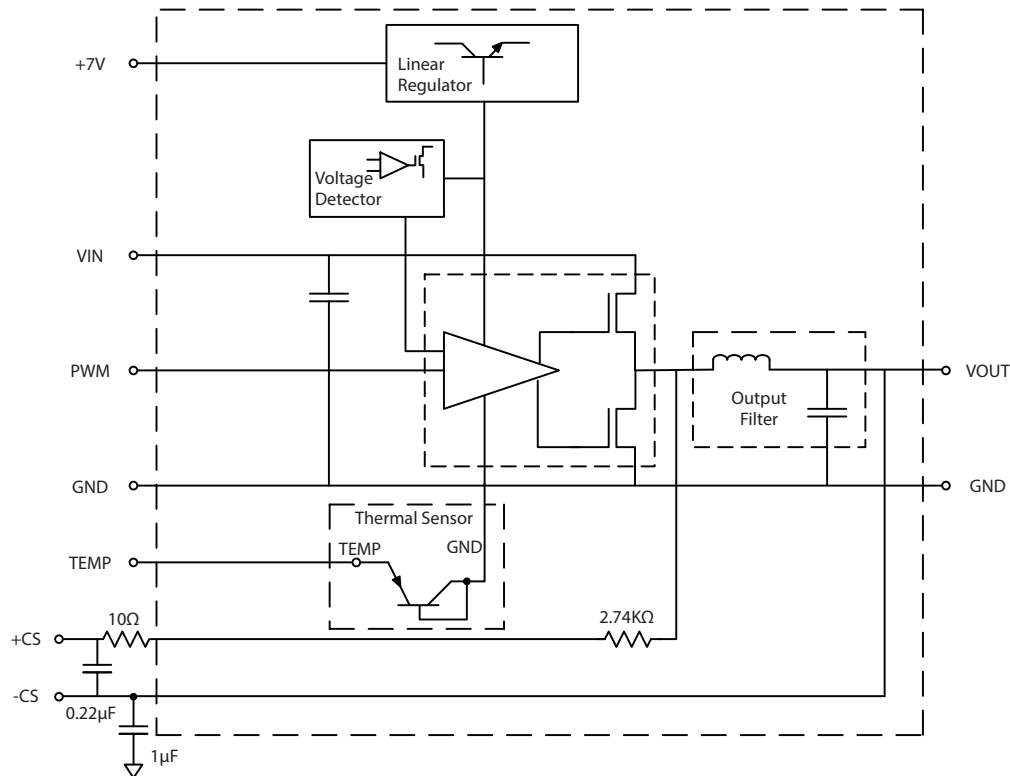

Figure 1. Block diagram of one of the two phases



PERFORMANCE SPECIFICATIONS SUMMARY AND ORDERING GUIDE ①

Root Model	Output			Input			Efficiency ③	Dimensions
	Vout (Volts)	Iout (Amps, max.)	Power (Watts)	Vin nom. (Volts)	Range (Volts)	Iin, full load (Amps) ②		Inches (mm)
								Typ.
OKLP-X/60-W12A-C ①	0.6-3.63	60 ④	115.5	12	7-13.2	17.4	95.0%	1 x 0.5 x 0.48 (25.4 x 12.7 x 12.2)

- ① Typical at Ta = +25°C
- ② @Vin = 7V, Vout = 3.3V, Iout = 17.5A
- ③ @Vin = 12V, Vout = 3.3V, Iout = 17.5A
- ④ Two phases

PART NUMBER STRUCTURE

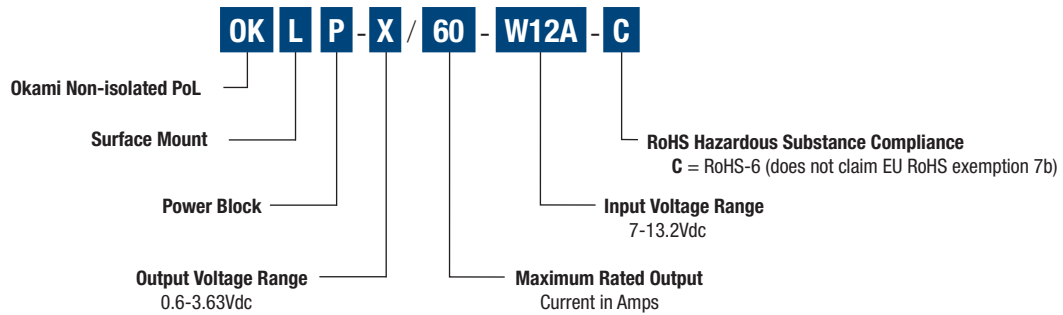

1. Input Requirements

1.1. Voltage:

Parameter	Notes	Min	Nom	Max	Units
Vin (Pin #9, 13): Operating Absolute max		7.0		13.2 15.0	V
+7V (Pin #4): Operating Under-voltage lockout, rising Under-voltage lockout, falling Hysteresis		6.7 5.7 5.1	7.0 6.0 5.3 0.67	7.5 6.3 5.5	V
PWM (Pin # 10, 12): High Low Tri-state current	1	2.5 -10		5.5 0.8 10	V μA

1. Sourcing or sinking current to/from PWM (Pin #) within the specified range will result in both high and low-side MOS-FET's to be held off by the gate-driver circuitry.

1.2. Current:

Parameter	Notes	Min	Nom	Max	Units
Vin = 7V, Vout = 3.3V, Iout = 35A (Switching at 400KHz)				21	A
Vin = 7V, Vout = 0.6V, Iout = 60A (Switching at 400KHz)				7.4	A
Vin = 12V, Vout = 0.6V, Iout = 60A (Switching at 400KHz)				4.4	A
+7V (Pin 5) (Switching at 500 KHz)				95	mA

2. Output Requirements

2.1. Voltage:

Parameter	Notes	Min	Nom	Max	Units
Operating Range		0.6		3.63	V

2.2. Current per Phase:

Parameter	Notes	Min	Nom	Max	Units
Operating Range					
0.6V to 1.32V	1	0		30	A
1.32V to 2.0V	1	0		25	A
2.0V to 3.63V	1	0		17.5	A

2.3. Power/Efficiency

Parameter		Notes	Min	Nom	Max	Units
Output Power					115.5	W
Efficiency:	Vout = 3.3V, Iout = 25A	1, 2		95		%
	Vout = 2.5V, Iout = 40A			94.5		
	Vout = 2.0V, Iout = 40A			93.5		
	Vout = 1.8V, Iout = 50A			92		
	Vout = 1V, Iout = 60A			87		
	Vout = 0.6V, Iout = 60A			82		

1. Switching at 400KHz, Vin = 12V with 200 LFM at 25°C.
2. Gate drive and controller losses are included.

2.4. Capacitor

Parameter	Notes	Min	Nom	Max	Units
Input Capacitance	1		60		μF
Output Capacitance	1		20		μF

1. Additional input and output capacitors are to be added externally as part of the buck regulator design.

2.5. Resistor

Parameter	Notes	Min	Nom	Max	Units
Output-to-GND Resistor	1		200		Ω

1. 0603 resistor.

2.6. Inductor

Parameter	Notes	Min	Nom	Max	Units
Inductance		243	270	297	nH
DCR (25C)	1	0.40	0.43	0.46	mΩ
Isat (125C)			39		A

1. See Block Diagram for DCR sense requirements.

2.7. Switching Frequency

Parameter	Notes	Min	Nom	Max	Units
Frequency		300	400	500	kHz

3. Temperature Sense

A PN junction shall be used, MMBT3906 with base and collector tied to ground. The PWM controller shall put out currents at different levels into the emitter, and calculate junction temperature by measuring emitter-to-base voltage at different current levels. There shall be a 10nF bypass capacitor.

4. Mechanical

4.1. General

Single-board, designed for machine pick-N-place. Footprint is 0.5" x 1.0". Maximum height is 0.48".

4.2.

Parameter	Notes	Nom	Units
Dimensions		1 x 0.5 x 0.48	inches
		25.4x 12.7x 12.2	mm
Weight		0.38	ounces
		10.78	grams

4.3. Pinout

Pin #	Name	Function
1	CS1-	Negative DCR sense for phase1
2	Gnd	Ground
3	Vout1	Output voltage for phase1
4	+7v	Input voltage for gate driver
5	Vout2	Output voltage for phase2
6	Gnd	Ground
7	CS2-	Negative DCR sense for phase2
8	CS2+	Positive DCR sense for phase2
9	Vin	Input supply voltage
10	PWM2	Phase2 Pulse Width Modulation input
11	Gnd	Ground
12	PWM1	Phase1 Pulse Width Modulation input
13	Vin	Input supply voltage
14	CS1+	Positive DCR sense for phase1
15	Temp1	From temperature sense device on the power block for temperature sensing for phase 1.
16	Temp2	From temperature sense device on the power block for temperature sensing for phase 2.

4.4. Mechanical Specifications

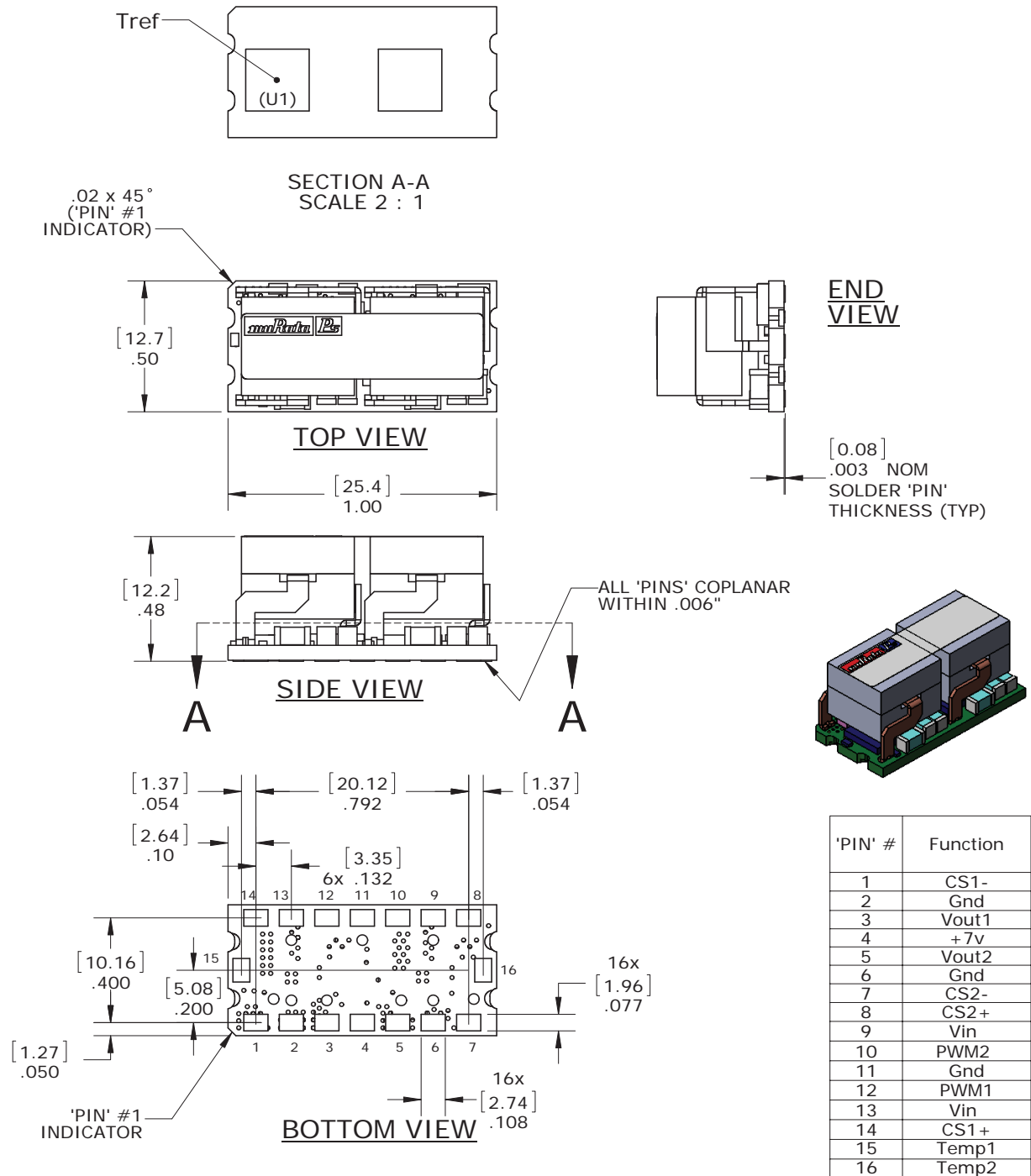

DIMENSIONS ARE IN INCHES [mm]

TOLERANCES:
 2 PLACE ±.02
 3 PLACE ±.010

ANGLES: ±1°

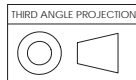

COMPONENTS SHOWN ARE FOR REFERENCE ONLY

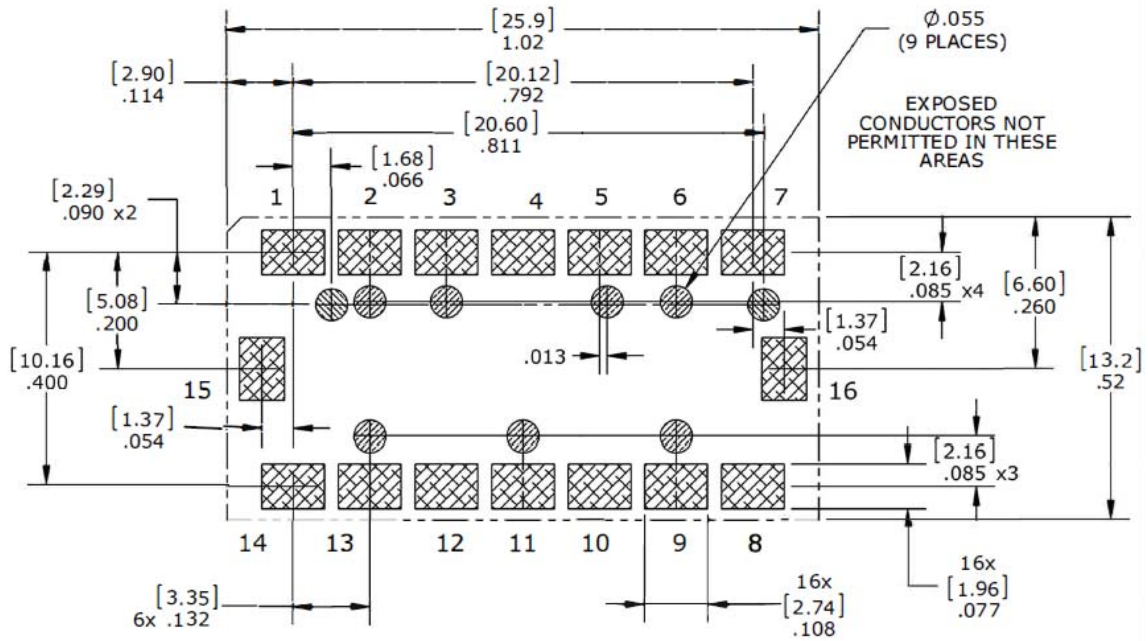

**RECOMMENDED PAD LAYOUT AND FOOTPRINT
(VIEWED THROUGH POWER BLOCK)**

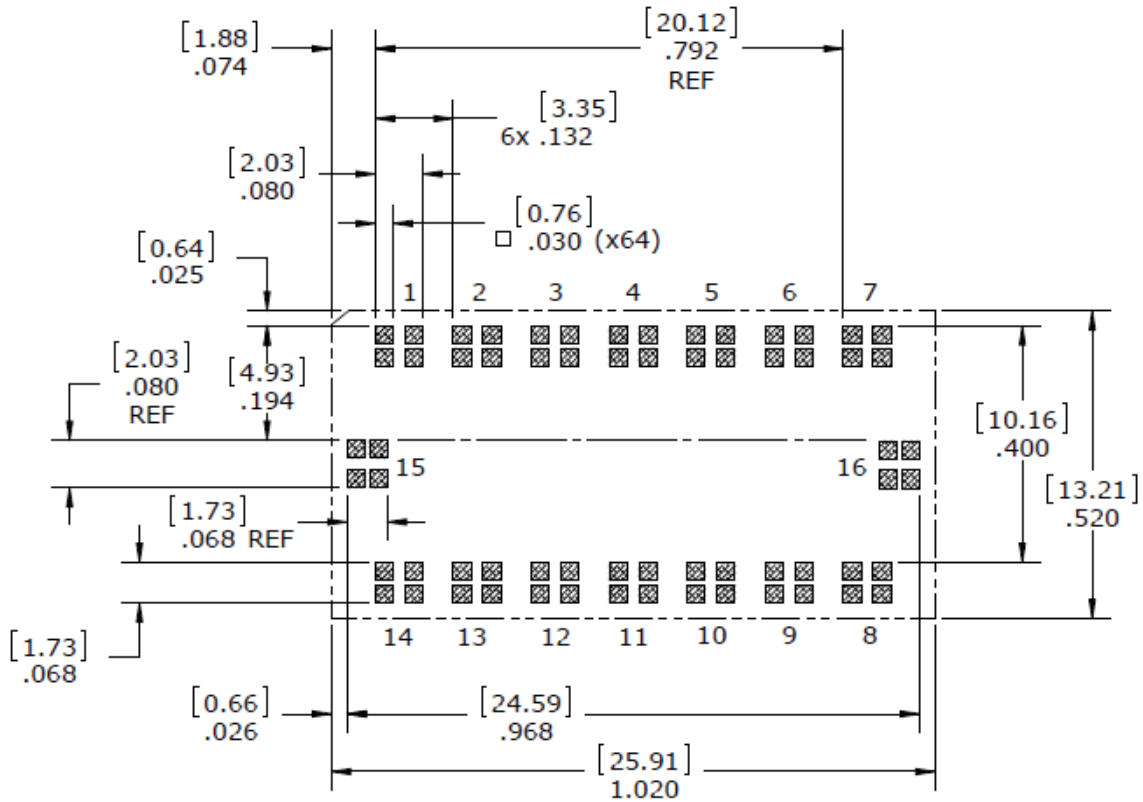

**RECOMMENDED SOLDER STENCIL
(VIEWED THROUGH POWER BLOCK)**

Tape and Reel Information (MSL Rating 3)

FEED (UNWIND) DIRECTION 

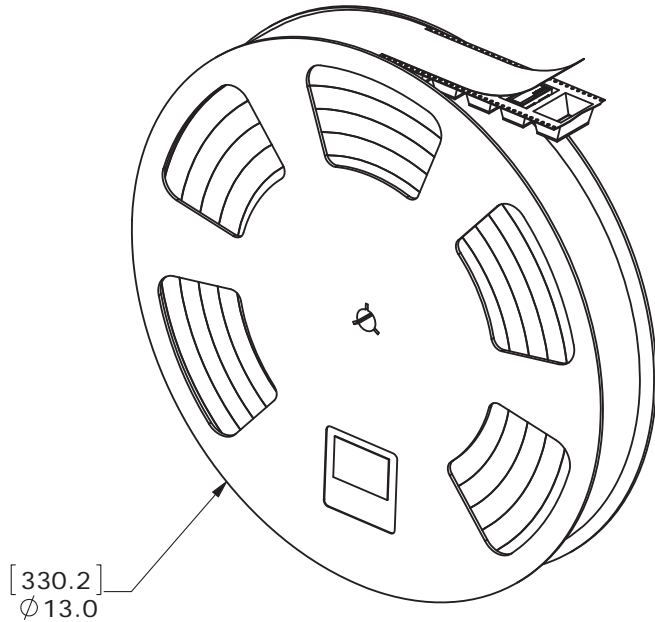

7770234 SHIPPING KIT
TAPE AND REEL WITH MSL3
PACKAGING (NOT SHOWN)
200 UNITS PER REEL

FEED (UNWIND) DIRECTION 

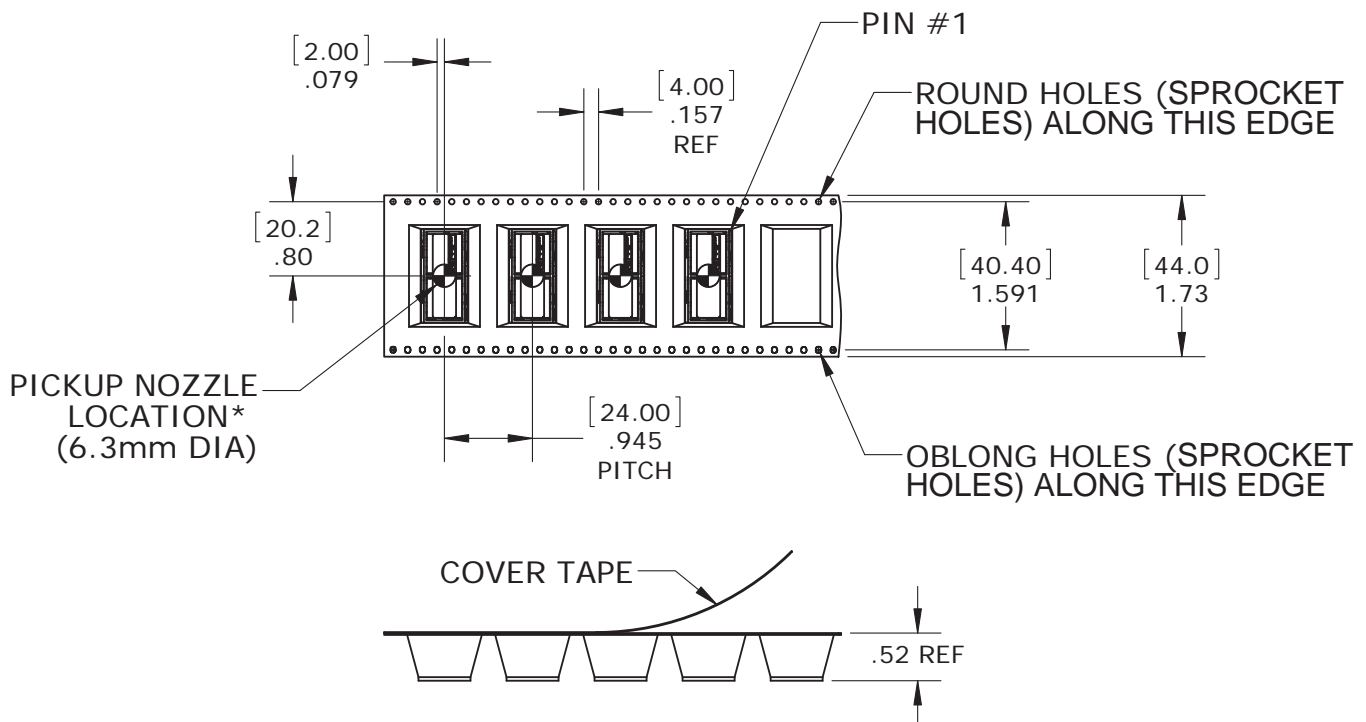

5. Miscellaneous

5.1. Environmental

Parameter	Notes	Min	Nom	Max	Units
Temperature, Operating, Long-Term		-40	-	85	°C
Temperature, Storage		-40	-	125	°C
Available airflow (along either long or short side)		200	-	-	LFM
Altitude, Operating	1	-500	-	10,000	Feet
Relative Humidity, Operating, Non-Condensing		10	-	90	%
MSL Rating 3					

1. Derate operating temperature 1°C per 1000 Feet of altitude above sea-level.

5.2. Reliability

1. Calculated according to Bellcore or Telcordia TR-NTW-000332 at 40C full-load.
2. Calculated at 30 °C.

Parameter	Notes	Min	Nom	Max	Units
Calculated MTBF	1	-	TBD	-	MHrs

5.3. Parallel Operation

2 or more units will be operated in parallel. Current sharing function will be performed by the external PWM controller.

5.4. SMT Reflow Soldering Guidelines

The surface-mount reflow solder profile shown below is suitable for the recommended SAC305 type lead-free solders. This graph should be used only as a guideline. Many other factors influence the success of SMT reflow soldering. Since your production environment may differ, please thoroughly review these guidelines with your process engineers.

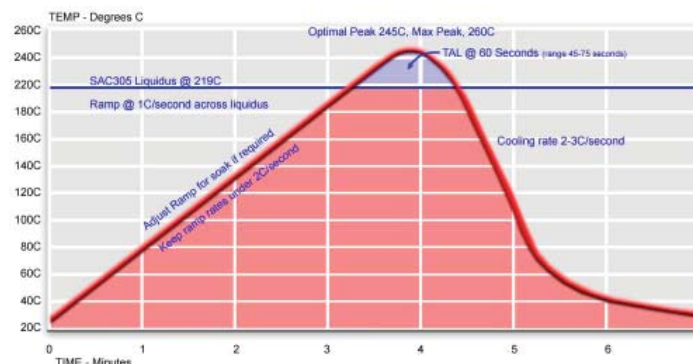

TYPICAL PERFORMANCE DATA

Efficiency vs. Line Voltage and Load Current @ +25°C. (Vout = 0.6V)

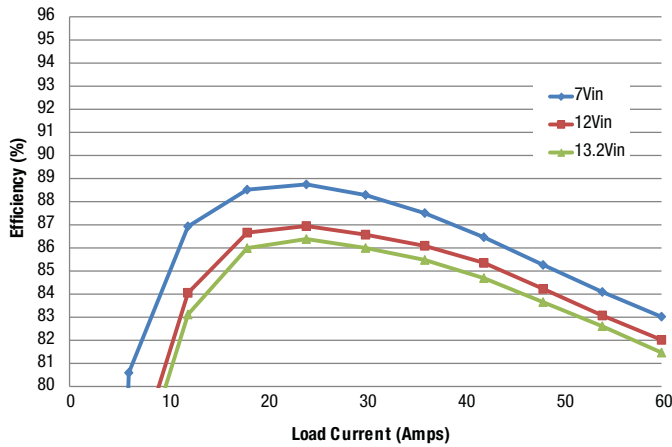

Efficiency vs. Line Voltage and Load Current @ +25°C. (Vout = 1.0V)

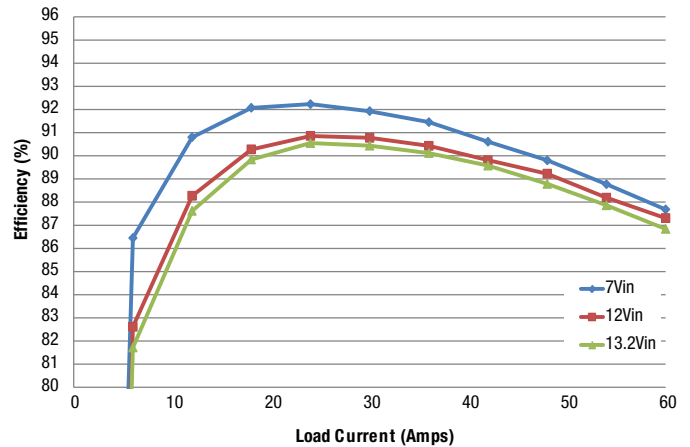

Efficiency vs. Line Voltage and Load Current @ +25°C. (Vout = 1.8V)

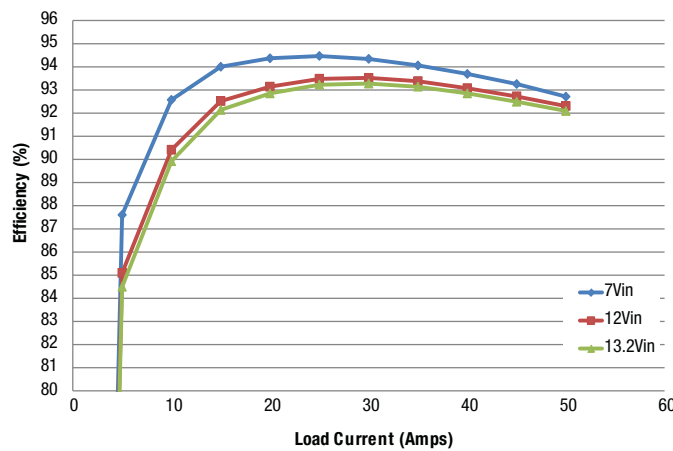

Efficiency vs. Line Voltage and Load Current @ +25°C. (Vout = 2.5V)

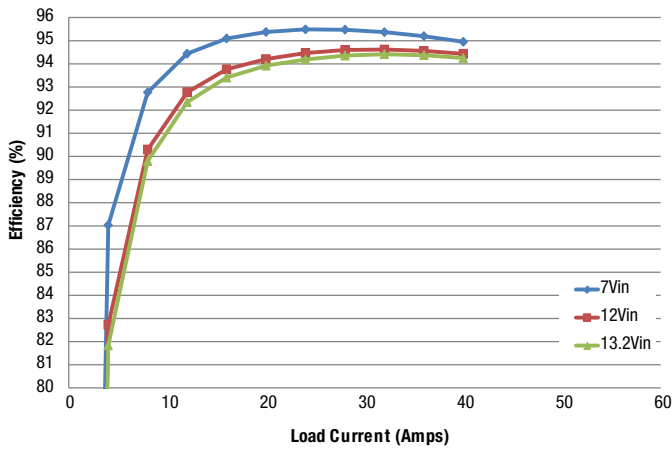

Efficiency vs. Line Voltage and Load Current @ +25°C. (Vout = 3.3V)

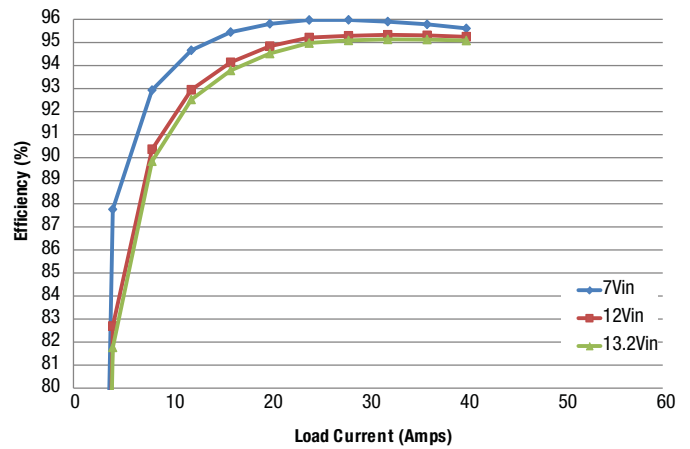

TYPICAL PERFORMANCE DATA

Temperature Derating @1Vout
Vin 12V (airflow from Pin 1 to Pin 7 on PCB)

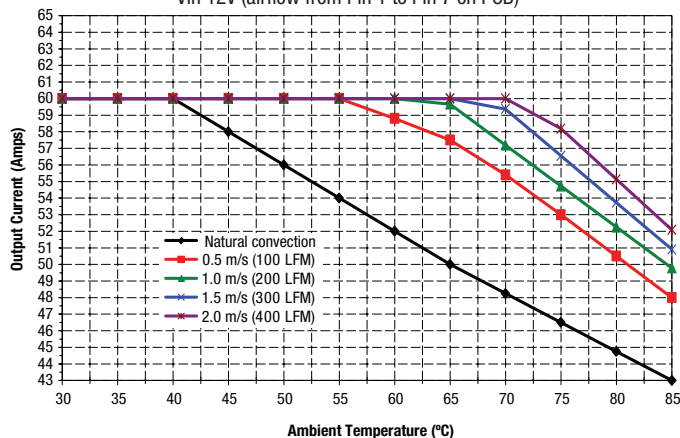

Temperature Derating @1.3Vout
Vin 12V (airflow from Pin 1 to Pin 7 on PCB)

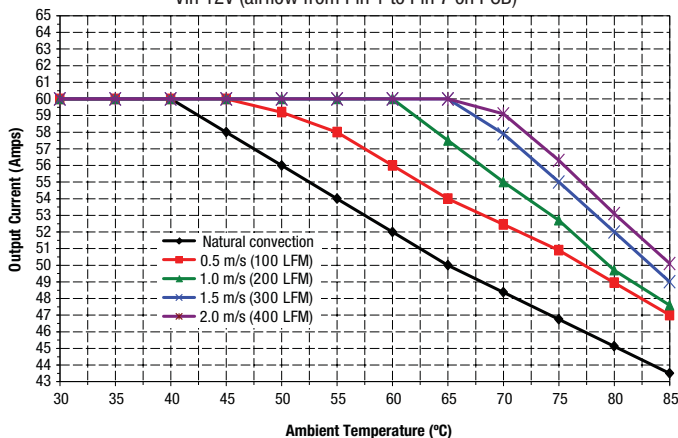

Temperature Derating @1.8Vout
Vin 12V (airflow from Pin 1 to Pin 7 on PCB)

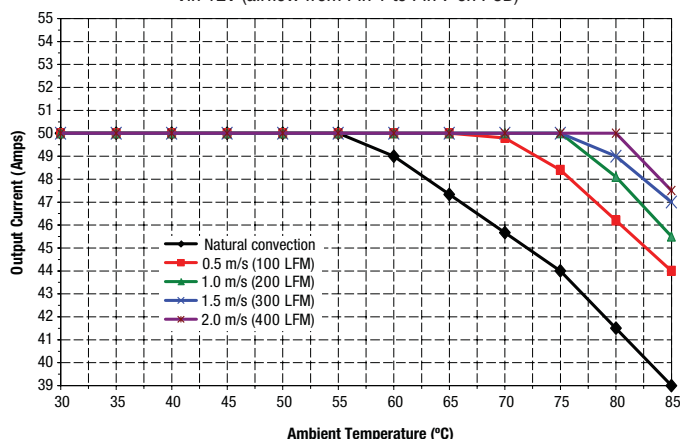

Temperature Derating @2.5Vout
Vin 12V (airflow from Pin 1 to Pin 7 on PCB)

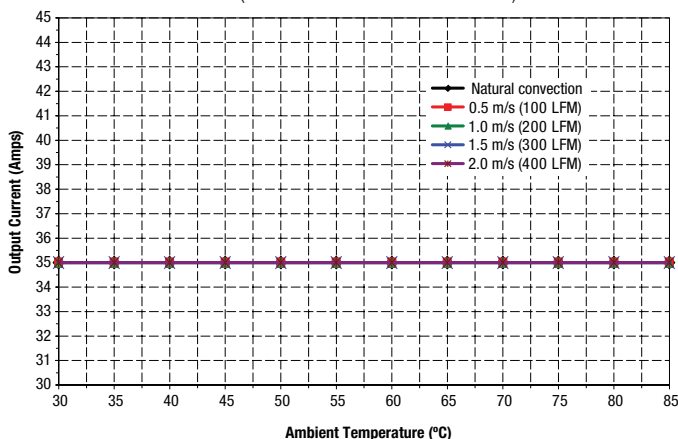

Temperature Derating @3.3Vout
Vin 12V (airflow from Pin 1 to Pin 7 on PCB)

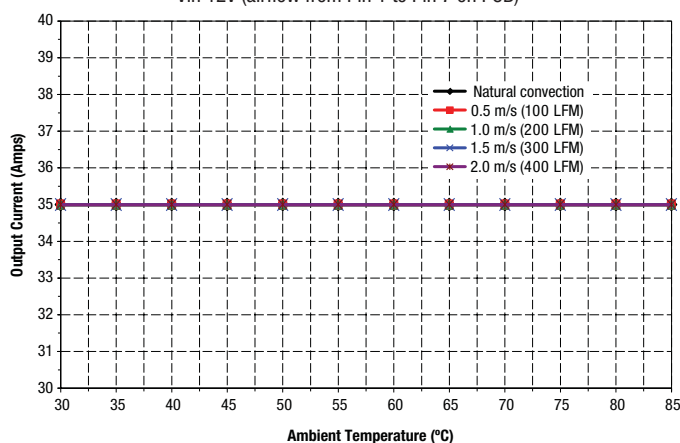

*The hottest component is U1; its operating temperature (Tref as indicated in section 4.4) has a maximum limit of 125°C. For reliable operation, the temperature at this point should not exceed 125°C in customer's application.

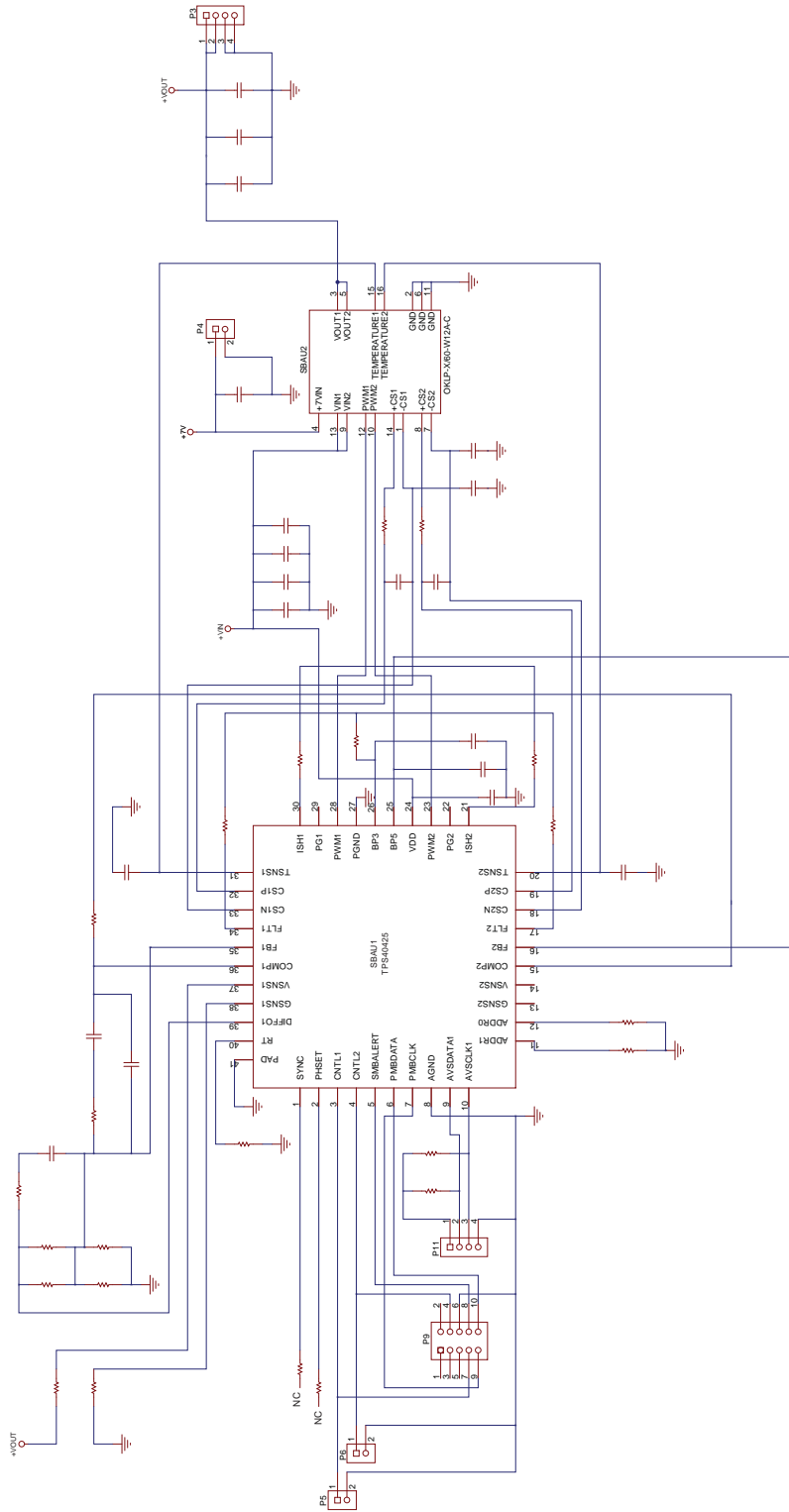

Figure 2. Typical OKLP-X/60-W12A-C controller implementation
For more details, click here to see Application Note AN67, Evaluation Boards for OKLP-X/60-W12A-C.

Murata Power Solutions, Inc.
129 Flanders Road, Westborough, MA 01581 U.S.A.
ISO 9001 and 14001 REGISTERED



This product is subject to the following operating requirements and the Life and Safety Critical Application Sales Policy:
Refer to: <http://www.murata-ps.com/requirements/>

Murata Power Solutions, Inc. makes no representation that the use of its products in the circuits described herein, or the use of other technical information contained herein, will not infringe upon existing or future patent rights. The descriptions contained herein do not imply the granting of licenses to make, use, or sell equipment constructed in accordance therewith. Specifications are subject to change without notice.
© 2018 Murata Power Solutions, Inc.

X-ON Electronics

Largest Supplier of Electrical and Electronic Components

Click to view similar products for [Non-Isolated DC/DC Converters](#) category:

Click to view products by [Murata](#) manufacturer:

Other Similar products are found below :

[BRFS50](#) [APTH003A0X-SRZ](#) [SPM1004-3V3C](#) [R-785.0-05](#) [BRFS30](#) [PJT020A0X43-SRZ](#) [10E24-P15-10PPM](#) [1E24-P4-25PPM-SHV-5KV](#)
[CA-17205-L4](#) [4D15-N1](#) [MYGTM01210BZN](#) [APXW012A0X3-SRDZ](#) [I6A24008A033V-N00-R](#) [10C24-N250-I10-AQ-DA](#) [4AA24-P20-M-H](#)
[DX150N](#) [3V12-N0.8](#) [2HVA24-BP1-F-25PPM-SHV-5KV](#) [5HVA24-BP1-F-25PPM-SHV-5KV](#) [1/2AA24-P30-I10](#) [1C24-P20-M-C](#) [VI-](#)
[920194B](#) [T31SN24005NMFA](#) [3V24-P1](#) [3V24-N1](#) [BMR4672010/001](#) [BMR4652010/001](#) [BMR4668004/001](#) [T31SN12008NMFA](#) [6AA24-](#)
[P30-I5-M](#) [6AA24-N30-I5-M](#) [1046805](#) [PTV03020WAH](#) [PTV05020WAH](#) [PTV12010LAH](#) [PTV12020WAD](#) [R-625.0D](#) [R-7212D](#) [R-7212P](#)
[R-745.0D](#) [R-78AA15-0.5SMD](#) [R-78AA5.0-1.0SMD](#) [30A24-N15-E](#) [10A12-P4-M](#) [10C24-N250-I5](#) [10C24-P125](#) [10C24-P250-I5](#) [6A24-P20-](#)
[I10-F-M-25PPM](#) [1A24-P30-F-M-C](#) [TSR 1-24150SM](#)