

## PRF Series

## PTC Thermistor PRF Series



### Features

- Faster response
- Wide Sensing Temperature
- Compact Design to save Board space
- Low profile
- High Reliability
- RoHS Compliant and Halogen Free
- Safety Standard  
(UL : E137188 VDE, TUV etc.)

### Applications

- Automotive  
(LED Lamp/Navigation/Motor/Electrical Component)
- LED Bulb
- Mobile phone
- Note PC, Tablet PC
- Battery
- Power Supply
- Motor and Motor Controller

## Overview

Exploiting the PTC characteristic (a sharp increase in resistance above a certain temperature), the PRF series chip PTC thermistors are used for overheat sensing in FETs, power ICs, and other heat generating areas. Use of the sharp change in electrical resistance translates into outstanding noise resistance. Sharp changes in resistance make it possible to accurately detect overheating in multiple areas using a very simple circuit connecting PTC thermistors in series.

This allows the customer to reduce the number of IC ports, thereby downsizing equipment.

---

### Attention:

This datasheet is downloaded from the website of Murata Manufacturing Co., Ltd.  
Therefore, it's specifications are subject to change or our products in it may be discontinued without advance notice.  
Please check with our sales representatives or product engineers before ordering.

## TABLE OF CONTENT

|  |           |
|--|-----------|
| <b>1. Introduction</b> .....                                   | <b>1</b>  |
| <b>2. Selection Guide</b> .....                                | <b>3</b>  |
| 2.1 Part Numbering   |           |
| <b>3. Specifications</b> .....                                 | <b>4</b>  |
| 3.1 Line up  |           |
| 3.2 Resistance-Temperature Characteristics Typical Curve       |           |
| 3.3 Electrical characteristics                                 |           |
| 3.4 Mechanical characteristics                                 |           |
| 3.5 Environmental characteristics                              |           |
| <b>4. Measurement direction</b> .....                          | <b>8</b>  |
| 4.1 Resistance - Temperature characteristics Range (Reference) |           |
| 4.2 Circuit (Reference)  |           |
| <b>5. Dimension, Land Pattern</b> .....                        | <b>9</b>  |
| <b>6. Packing</b> .....  | <b>10</b> |
| 6.1 Taping Specification                                       |           |
| 6.2 Reeling  |           |
| <b>7. ⚠CAUTION</b> .....                                       | <b>12</b> |

---

### Attention:

This datasheet is downloaded from the website of Murata Manufacturing Co., Ltd.  
Therefore, it's specifications are subject to change or our products in it may be discontinued without advance notice.  
Please check with our sales representatives or product engineers before ordering.

## 2. Selection Guide

### 2.1 Part Numbering

PTC Thermistors (POSISTOR®) for Overheat Sensing Chip Type

(Part Number)

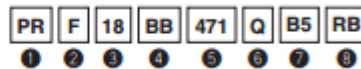

#### 1. Product ID

| Product ID |                           |
|------------|---------------------------|
| <b>PR</b>  | PTC Thermistors Chip Type |

#### 2. Series

| Code     | Series               |
|----------|----------------------|
| <b>F</b> | for Overheat Sensing |

#### 3. Dimensions

| Code      | Dimensions    |
|-----------|---------------|
| <b>15</b> | 1.00 × 0.50mm |
| <b>18</b> | 1.60 × 0.80mm |
| <b>21</b> | 2.00 × 1.25mm |

#### 4. Temperature Characteristics

| Code      | Temperature Characteristics |
|-----------|-----------------------------|
| <b>AS</b> | Curie Point 130°C           |
| <b>AR</b> | Curie Point 120°C           |
| <b>BA</b> | Curie Point 110°C           |
| <b>BB</b> | Curie Point 100°C           |
| <b>BC</b> | Curie Point 90°C            |
| <b>BD</b> | Curie Point 80°C            |
| <b>BE</b> | Curie Point 70°C            |
| <b>BF</b> | Curie Point 60°C            |
| <b>BG</b> | Curie Point 50°C            |

#### 5. Resistance

Expressed by three figures. The unit is (Ω).

The first and second figures are significant digits, and the third figure expresses the number of zeros which follow the two figures.

Ex.)

| Code       | Resistance |
|------------|------------|
| <b>471</b> | 470 Ω      |
| <b>102</b> | 1k Ω       |
| <b>103</b> | 10k Ω      |

#### 6. Resistance Tolerance

| Code     | Sensing Temp. Tolerance |
|----------|-------------------------|
| <b>Q</b> | +/-5 °C                 |
| <b>R</b> | +/-3 °C                 |

#### 7. Individual Specifications

Ex.)

| Code              | Individual Specifications |
|-------------------|---------------------------|
| <b>B5, B6, B7</b> | Structure, others         |

#### 8. Packaging

| Code      | Packaging                           |
|-----------|-------------------------------------|
| <b>RA</b> | Plastic Taping 4mm Pitch (4000pcs.) |
| <b>RB</b> | Paper Taping 4mm Pitch (4000pcs.)   |
| <b>RC</b> | Paper Taping 2mm Pitch (10000pcs.)  |

#### Attention:

This datasheet is downloaded from the website of Murata Manufacturing Co., Ltd. Therefore, its specifications are subject to change or our products in it may be discontinued without advance notice. Please check with our sales representatives or product engineers before ordering.

### 3. Specifications

#### 3.1 Line up

| Size<br>[ mm/in. ] | Part Number     | Resistance<br>at 25°C [ ohm ] | *at 4.7kohm                | *at 47kohm                     | Max. Voltage<br>[ VDC ] | Operation Temp.<br>[ °C ] |
|--------------------|-----------------|-------------------------------|----------------------------|--------------------------------|-------------------------|---------------------------|
|                    |                 |                               | Sensing<br>Temperature(°C) | Sensing<br>Temperature(2) (°C) |                         |                           |
| 2012/0805          | PRF21AS471QB5RA | 470+/-50%                     | 145+/-5                    | -                              | 32V                     | -20~+160                  |
|                    | PRF21AR471QB5RA | 470+/-50%                     | 135+/-5                    | -                              | 32V                     | -20~+150                  |
|                    | PRF21BA471QB5RA | 470+/-50%                     | 125+/-5                    | -                              | 32V                     | -20~+140                  |
|                    | PRF21BB471QB5RA | 470+/-50%                     | 115+/-5                    | -                              | 32V                     | -20~+130                  |
|                    | PRF21BC471QB5RA | 470+/-50%                     | 105+/-5                    | -                              | 32V                     | -20~+120                  |
|                    | PRF21BD471QB5RA | 470+/-50%                     | 95+/-5                     | -                              | 32V                     | -20~+110                  |
|                    | PRF21BE471QB5RA | 470+/-50%                     | 85+/-5                     | -                              | 32V                     | -20~+100                  |
| 1608/0603          | PRF18AS471QB5RB | 470+/-50%                     | 145+/-5                    | -                              | 32V                     | -20~+160                  |
|                    | PRF18AR471QB5RB | 470+/-50%                     | 135+/-5                    | 150+/-7                        | 32V                     | -20~+160                  |
|                    | PRF18BA471QB5RB | 470+/-50%                     | 125+/-5                    | 140+/-7                        | 32V                     | -20~+150                  |
|                    | PRF18BB471QB5RB | 470+/-50%                     | 115+/-5                    | 130+/-7                        | 32V                     | -20~+140                  |
|                    | PRF18BC471QB5RB | 470+/-50%                     | 105+/-5                    | 120+/-7                        | 32V                     | -20~+130                  |
|                    | PRF18BD471QB5RB | 470+/-50%                     | 95+/-5                     | 110+/-7                        | 32V                     | -20~+120                  |
|                    | PRF18BE471QB5RB | 470+/-50%                     | 85+/-5                     | 100+/-7                        | 32V                     | -20~+110                  |
|                    | PRF18BF471QB5RB | 470+/-50%                     | 75+/-5                     | 90+/-7                         | 32V                     | -20~+100                  |
|                    | PRF18BG471QB5RB | 470+/-50%                     | 65+/-5                     | 80+/-7                         | 32V                     | -20~+90                   |
|                    | PRF18BB471RB5RB | 470+/-50%                     | 115+/-3                    | 130+/-7                        | 32V                     | -20~+140                  |
|                    | PRF18BC471RB5RB | 470+/-50%                     | 105+/-3                    | 120+/-7                        | 32V                     | -20~+130                  |
|                    | PRF18BD471RB5RB | 470+/-50%                     | 95+/-3                     | 110+/-7                        | 32V                     | -20~+120                  |
|                    | PRF18BE471RB5RB | 470+/-50%                     | 85+/-3                     | 100+/-7                        | 32V                     | -20~+110                  |
|                    | PRF18BF471RB5RB | 470+/-50%                     | 75+/-3                     | 90+/-7                         | 32V                     | -20~+100                  |
|                    | PRF18BG471RB5RB | 470+/-50%                     | 65+/-3                     | 80+/-7                         | 32V                     | -20~+90                   |
|                    | PRF18BC471MB7RB | 470+/-20%                     | 105+/-3                    | -                              | 32V                     | -20~+130                  |
|                    | PRF18BD471MB7RB | 470+/-20%                     | 95+/-3                     | -                              | 32V                     | -20~+120                  |
| PRF18BE471MB7RB    | 470+/-20%       | 85+/-3                        | -                          | 32V                            | -20~+110                |                           |
| Size<br>[ mm/in. ] | Part Number     | Resistance<br>at 25°C [ ohm ] | *at 10kohm                 | *at 100kohm                    | Max. Voltage<br>[ VDC ] | Operation Temp.<br>[ °C ] |
|                    |                 |                               | Sensing<br>Temperature(°C) | Sensing<br>Temperature(2) (°C) |                         |                           |
| 1005/0402          | PRF15AR102RB6RC | 1k+/-50%                      | 135+/-5                    | 150+/-3                        | 32V                     | -40~+160                  |
|                    | PRF15BA102RB6RC | 1k+/-50%                      | 125+/-5                    | 140+/-3                        | 32V                     | -40~+150                  |
|                    | PRF15BB102RB6RC | 1k+/-50%                      | 115+/-5                    | 130+/-3                        | 32V                     | -40~+140                  |
|                    | PRF15BC102RB6RC | 1k+/-50%                      | 105+/-5                    | 120+/-3                        | 32V                     | -40~+130                  |
|                    | PRF15BD102RB6RC | 1k+/-50%                      | 95+/-5                     | 110+/-3                        | 32V                     | -40~+120                  |
|                    | PRF15BE102RB6RC | 1k+/-50%                      | 85+/-5                     | 100+/-3                        | 32V                     | -40~+110                  |
|                    | PRF15BF102RB6RC | 1k+/-50%                      | 75+/-5                     | 90+/-3                         | 32V                     | -40~+100                  |
|                    | PRF15BG102RB6RC | 1k+/-50%                      | 65+/-5                     | 80+/-3                         | 32V                     | -40~+90                   |
| Size<br>[ mm/in. ] | Part Number     | Resistance<br>at 25°C [ ohm ] | *at 100kohm                | *at 4.7Mohm                    | Max. Voltage<br>[ VDC ] | Operation Temp.<br>[ °C ] |
|                    |                 |                               | Sensing<br>Temperature(°C) | Sensing<br>Temperature(2) (°C) |                         |                           |
| 1005/0402          | PRF15BB103RB6RC | 10k+/-50%                     | > 110                      | 130+/-3                        | 32V                     | -20~+140                  |
|                    | PRF15BE103RB6RC | 10k+/-50%                     | -                          | 100+/-3                        | 32V                     | -20~+110                  |
|                    | PRF15BG103RB6RC | 10k+/-50%                     | -                          | 80+/-3                         | 32V                     | -20~+90                   |

#### Attention:

This datasheet is downloaded from the website of Murata Manufacturing Co., Ltd.  
Therefore, it's specifications are subject to change or our products in it may be discontinued without advance notice.  
Please check with our sales representatives or product engineers before ordering.

### 3.2 Resistance-Temperature Characteristics Typical Curve

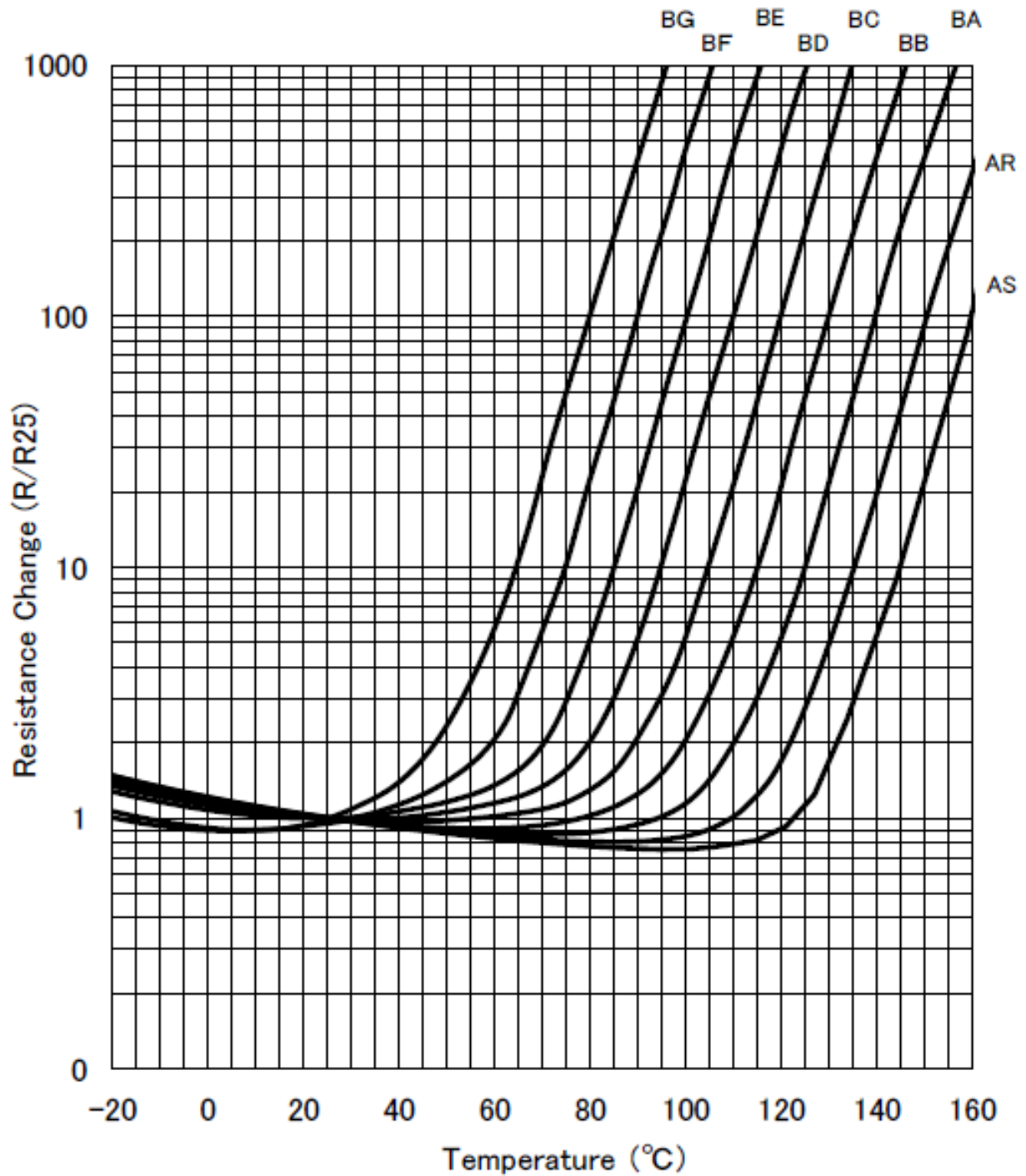

**Attention:**

This datasheet is downloaded from the website of Murata Manufacturing Co., Ltd. Therefore, its specifications are subject to change or our products in it may be discontinued without advance notice. Please check with our sales representatives or product engineers before ordering.

### 3.3 Electrical characteristics

|       | Item                        | Specification  | Test Condition  |
|-------|-----------------------------|--|---|
| 3.3.1 | Resistance value at 25°C    | Within the specified range   | After applying maximum operating voltage for 3 mins.<br>and leaving for 2 hours in 25°C, measured by applying voltage less than DC1.0V. |
| 3.3.2 | Temperature characteristics | The resistance change with temperature typical curve shown in Graph-1. | Resistance at each ambient temperature is Measured by the measurement current of 1mA or less.   |

### 3.4 Mechanical characteristics

|       | Item                         | Specification  | Test Condition   |
|-------|------------------------------|--|--|
| 3.4.1 | Vibration                    | <ul style="list-style-type: none"> <li>• Resistance (R25) change:<br/>Less than +/-20% (#)</li> <li>• Appearance:<br/>No defects or abnormalities</li> </ul> | Reference standard: IEC 60068-2-6 (1995)<br><ul style="list-style-type: none"> <li>•Soldered PTC to PCB (##)</li> <li>•Frequency range: 10~55Hz</li> <li>•Amplitude: 1.5mm</li> <li>•Sweep rate: 1octave/min.</li> <li>•Direction: X-Y-Z (3 direction)</li> <li>•24 cycles in each axis</li> </ul> |
| 3.4.2 | Solderability                | Wetting of soldering area:<br>≥95%   | Reference standard: IEC 60068-2-58 (2004)<br><ul style="list-style-type: none"> <li>•Solder: Sn-3.0Ag-0.5Cu</li> <li>•Solder temp.: 245+/-5°C</li> <li>•Immersion time: 3+/-0.3s</li> </ul>  |
| 3.4.3 | Resistance to soldering heat | <ul style="list-style-type: none"> <li>• Resistance (R25) change:<br/>Less than +/-20% (#)</li> <li>• Appearance:<br/>No defects or abnormalities</li> </ul> | Reference standard: IEC 60068-2-58 (2004)<br>[ Solder bath method ]<br><ul style="list-style-type: none"> <li>•Solder: Sn-3.0Ag-0.5Cu</li> <li>•Preheat: 150+/-5°C, 90~120s</li> <li>•Solder temp.: 260+/-5°C</li> <li>•Immersion time: 10+/-1s</li> </ul>   |

#### Attention:

This datasheet is downloaded from the website of Murata Manufacturing Co., Ltd.  
Therefore, it's specifications are subject to change or our products in it may be discontinued without advance notice.  
Please check with our sales representatives or product engineers before ordering.

### 3.5 Environmental characteristics

|       | Item                         | Specification  | Test Condition   |      |           |      |   |                              |        |   |                              |        |
|-------|------------------------------|--|--|------|-----------|------|---|------------------------------|--------|---|------------------------------|--------|
| 3.5.1 | Dry Heat                     | <ul style="list-style-type: none"> <li>• Resistance (R25) change: Less than +/-20% (#)</li> <li>• Appearance: No defects or abnormalities</li> </ul>   | Reference standard: IEC 60068-2-2 (2007) <ul style="list-style-type: none"> <li>• Soldered PTC to PCB (##)</li> <li>• (Max. operating temp.)+/-2°C</li> <li>• 1000+48/-0 hrs.</li> </ul>   |      |           |      |   |                              |        |   |                              |        |
| 3.5.2 | Cold                         |  | Reference standard: IEC 60068-2-1 (2007) <ul style="list-style-type: none"> <li>• Soldered PTC to PCB (##)</li> <li>• (Min. operating temp.)+/-3°C</li> <li>• 1000+48/-0 hrs</li> </ul>  |      |           |      |   |                              |        |   |                              |        |
| 3.5.3 | Damp heat                    |  | Reference standard: IEC 60068-2-67 (1995) <ul style="list-style-type: none"> <li>• Soldered PTC to PCB (##)</li> <li>• +85+/-2°C, 85+/-5%RH</li> <li>• 1000+48/-0 hrs</li> </ul>   |      |           |      |   |                              |        |   |                              |        |
| 3.5.4 | Thermal shock                |  | Reference standard: IEC 60068-2-14 (2009)<br>[ Test Na ] <ul style="list-style-type: none"> <li>• Soldered PTC to PCB (##)</li> <li>• Transport time: ≤3 min.</li> <li>• Test condition: See below table</li> </ul> <table border="1" data-bbox="826 1153 1455 1339"> <thead> <tr> <th>Step</th> <th>Condition</th> <th>Time</th> </tr> </thead> <tbody> <tr> <td>1</td> <td>(Min. operating temp.)+/-3°C</td> <td>30min.</td> </tr> <tr> <td>2</td> <td>(Max. operating temp.)+/-2°C</td> <td>30min.</td> </tr> </tbody> </table> <ul style="list-style-type: none"> <li>• Test cycle: 5cycles</li> </ul> | Step | Condition | Time | 1 | (Min. operating temp.)+/-3°C | 30min. | 2 | (Max. operating temp.)+/-2°C | 30min. |
| Step  | Condition                    |  | Time   |      |           |      |   |                              |        |   |                              |        |
| 1     | (Min. operating temp.)+/-3°C | 30min.   |  |      |           |      |   |                              |        |   |                              |        |
| 2     | (Max. operating temp.)+/-2°C | 30min.   |  |      |           |      |   |                              |        |   |                              |        |
| 3.5.5 | High temperature load        | Reference standard: IEC 60068-2-2 (2007) <ul style="list-style-type: none"> <li>• Soldered PTC to PCB (##)</li> <li>• (Max. operating temp.)+/-2°C</li> <li>• Applied max. voltage</li> <li>• 1000+48/-0 hrs.</li> </ul> |  |      |           |      |   |                              |        |   |                              |        |

# The resistance value after the test,

It is measured by applying voltage less than DC1.0V after left at 25±2°C for 2hrs.

## Above mentioned soldering is done following condition at our side.

- Glass-Epoxy PC board
- Standard land dimension
- Standard solder paste
- Standard solder profile

Above conditions are mentioned in Notice.

#### Attention:

This datasheet is downloaded from the website of Murata Manufacturing Co., Ltd. Therefore, it's specifications are subject to change or our products in it may be discontinued without advance notice. Please check with our sales representatives or product engineers before ordering.

## 4. Measurement direction

### 4.1 Resistance - Temperature characteristics Range (Reference)

Example PRF18 Series / BB Type

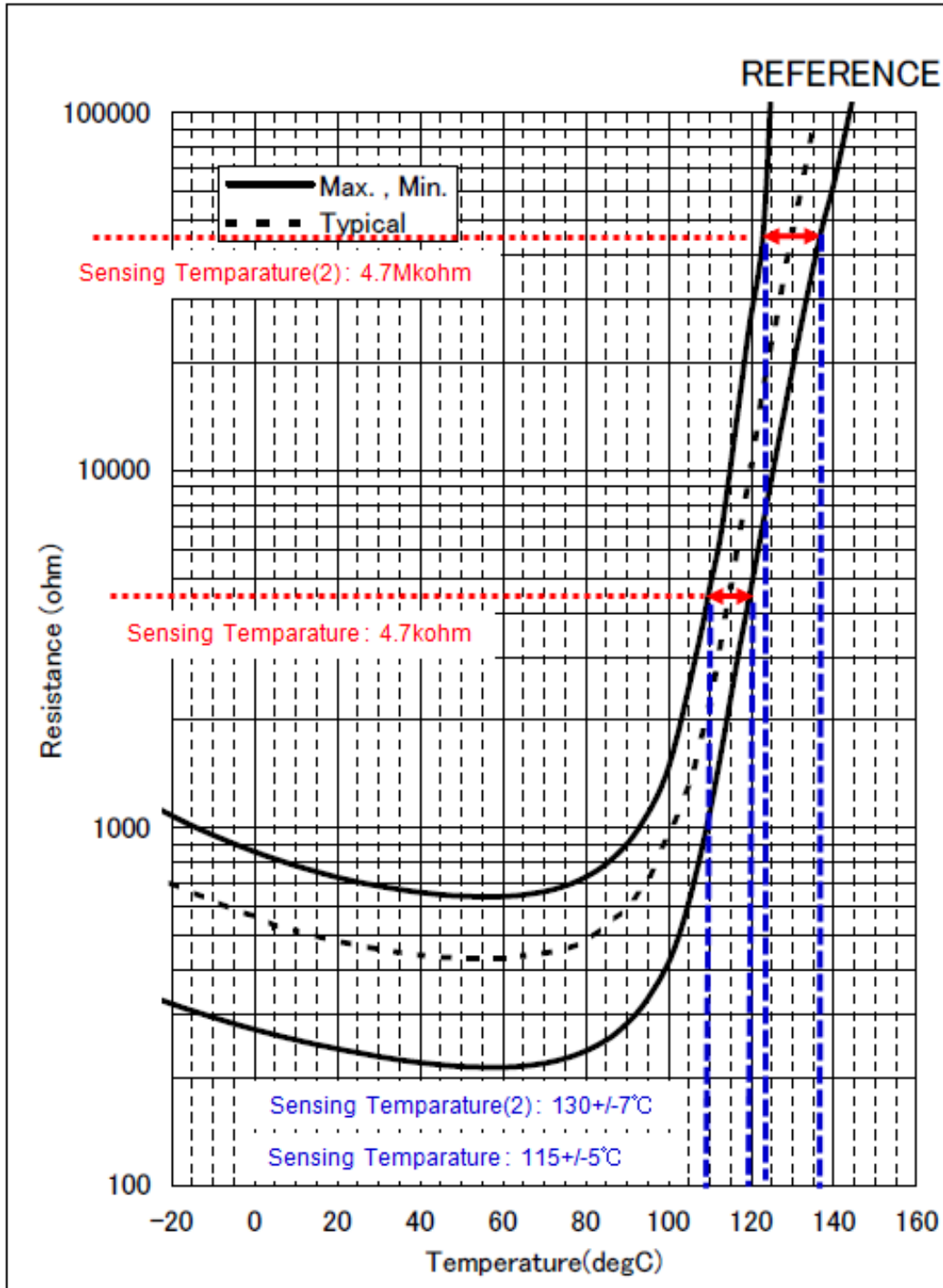

#### Attention:

This datasheet is downloaded from the website of Murata Manufacturing Co., Ltd. Therefore, its specifications are subject to change or our products in it may be discontinued without advance notice. Please check with our sales representatives or product engineers before ordering.



## 4.2 Circuit (Reference)

### Example

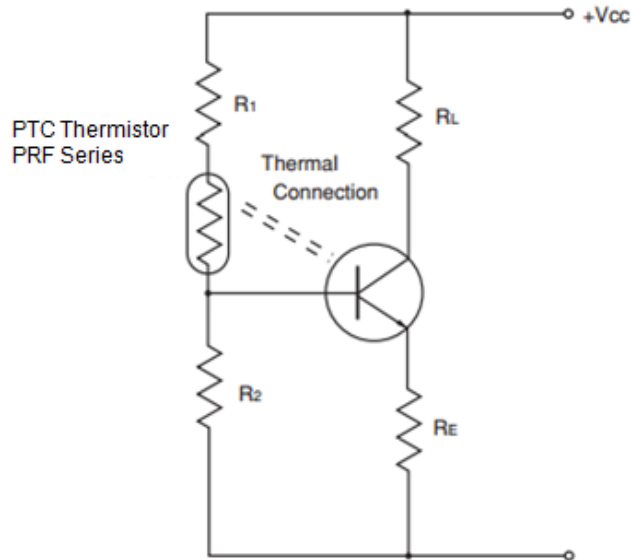

## 5. Dimension, Land Pattern

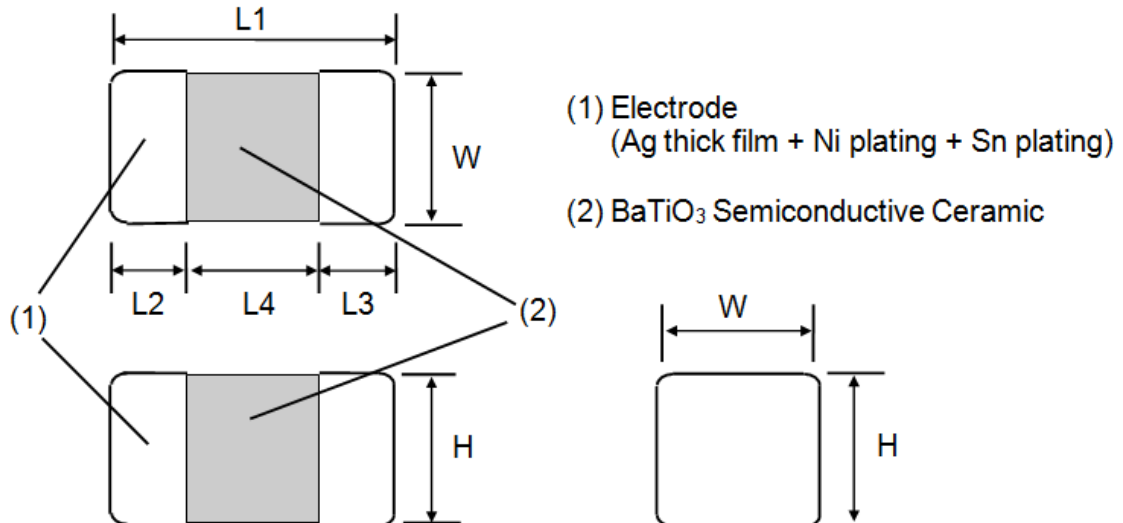

| Size[ mm/in.] | L1        | W         | H         | L2 and L3   | L4 (Min.) |
|---------------|-----------|-----------|-----------|-------------|-----------|
| 1005/0402     | 1.00±0.05 | 0.50±0.05 | 0.50±0.05 | 0.15~0.35   | 0.3       |
| 1608/0603     | 1.60±0.15 | 0.80±0.15 | 0.80±0.15 | 0.10 ~ 0.60 | -         |
| 2012/0805     | 2.00±0.20 | 1.25±0.20 | 0.90±0.20 | Min. 0.20   | Min. 0.50 |

### Attention:

This datasheet is downloaded from the website of Murata Manufacturing Co., Ltd. Therefore, its specifications are subject to change or our products in it may be discontinued without advance notice. Please check with our sales representatives or product engineers before ordering.

## 6. Packing

### 6.1 Taping Specification

#### 6.1.1 Dimensions of plastic tape (\*Typical data of PRF18\_RB Series)

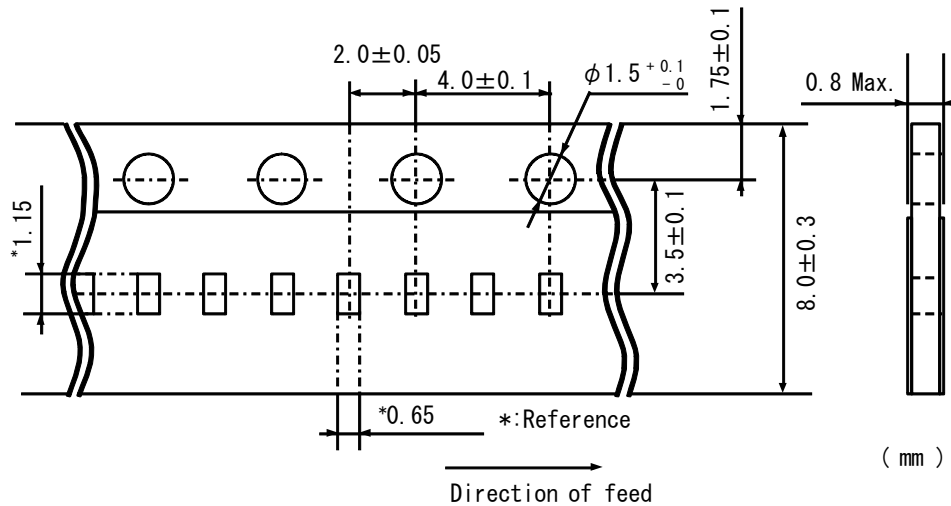

- (1) Products shall be packaged in the cavity of the base tape and sealed by top tape and bottom tape.
- (2) Top tape and bottom tape have no joints and products shall be packaged and sealed in the cavity of the base tape, continuously.

#### 6.1.2 Tape strength

(1) Pull strength of top tape and bottom tape shall be specified as follows:

| Size[ mm/in.] | Plastic tape | Cover tape  |
|---------------|--------------|-------------|
| 1005/0603     | 5N minimum   | 5N minimum  |
| 1608/0402     |              |             |
| 2012/0805     | 5N minimum   | 10N minimum |

(2) Peeling force of top tape

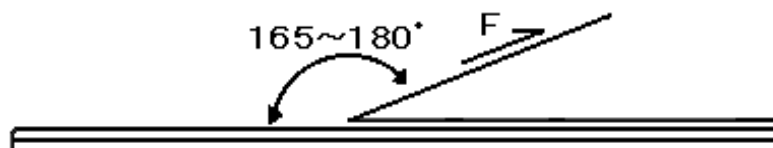

- \*1 peeling angle : 165 to 180 degree against the fixed surface of tape.
- \*2 peeling speed : 300mm/min.
- \*3 Peeling force : 0.1 ~ 0.6 N

#### Attention:

This datasheet is downloaded from the website of Murata Manufacturing Co., Ltd. Therefore, it's specifications are subject to change or our products in it may be discontinued without advance notice. Please check with our sales representatives or product engineers before ordering.

## 6.2 Reeling

### 6.1.1 Quantity (Standard Quantity)

| Part Number | Products quantity in a reel |
|-------------|-----------------------------|
| PRF15_RC    | 10,000 pcs. /reel           |
| PRF18_RB    | 4,000 pcs. /reel            |
| PRF21_RA    | 4,000 pcs. /reel            |

(2) A tape in a reel contains Leader unit and Trailer unit where products are not packed.

(See the following figure.)

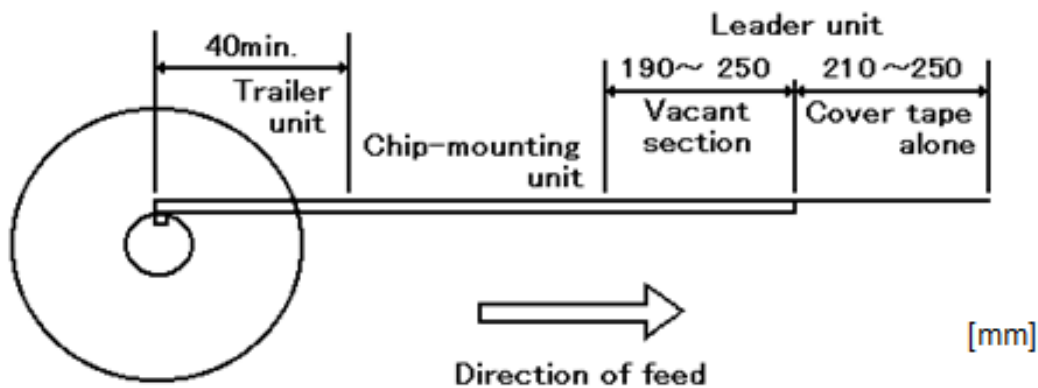

\* The reeling specification above shall not be applied for the order less than Standard Quantity.

(3) The plastic tape and cover tape are not attached at the end of the tape (Vacant section) for a minimum of 5 pitches.

(4) A label shall be attached on the reel.

(MURATA's part number, inspection number and quantity shall be marked on the label.)

(5) Dimensions of reel.

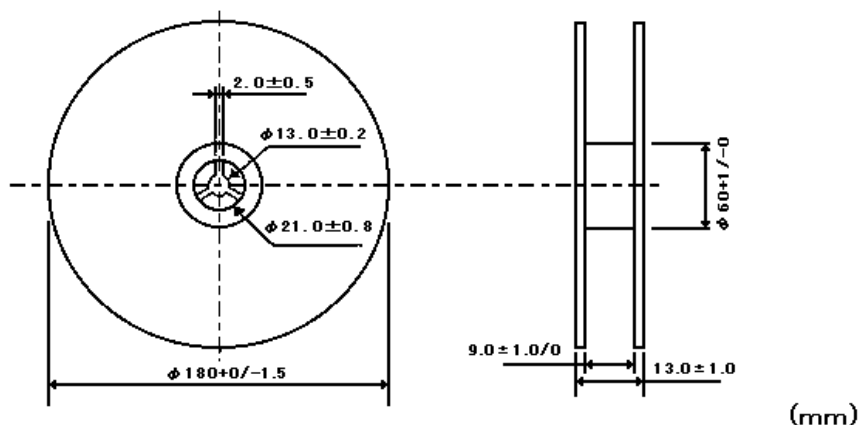

### 6.1.2 Packing

The reeling shall be packed in a package. The label shall be attached on the package.

(Customer's name, order number, customer's part number, MURATA's part number and quantity shall be marked on a label.)

#### Attention:

This datasheet is downloaded from the website of Murata Manufacturing Co., Ltd. Therefore, its specifications are subject to change or our products in it may be discontinued without advance notice. Please check with our sales representatives or product engineers before ordering.

## 7. Caution



1. This product is designed for application, which is used under ordinary environment. (room temperature, normal humidity, normal pressure) Do not expose this to the following environments, because all these factors can deteriorate the characteristic of this and can cause failure or burn out.

- (1) Corrosive gas or deoxidizing gases (Cl<sub>2</sub>, H<sub>2</sub>S, NH<sub>3</sub>, SO<sub>x</sub>, NO<sub>x</sub> etc.)
- (2) Volatile, flammable gas
- (3) Dusty place
- (4) Place in a vacuum, reducing or putting pressure
- (5) Place in splashed water, or high humidity and dewing place
- (6) Salt water, oil, chemical liquid and solvent
- (7) Vibratile place
- (8) Other place equivalent to the above

### 2. Limitation of Applications

Please contact us before using our products for the under-mentioned applications requiring especially high reliability in order to prevent defects which might directly cause damage to other party's life body or property (listed below).

- (1) Aircraft equipment      (2) Aerospace equipment      (3) Undersea equipment
- (4) Power plant control equipment      (5) Medical equipment
- (6) Transportation equipment (automobiles, trains, ships, etc.)      (7) Traffic signal equipment
- (8) Disaster prevention / Crime prevention equipment      (9) Data-processing equipment
- (10) Applications of similar complexity or with reliability requirements comparable to the applications listed in the above

3. Be sure to provide an appropriate fail-safe function on your product to prevent a second damage that may be caused by the abnormal function or the failure of our product.



1. Do not apply abnormal voltage exceeding the specified maximum value.  
Because they may deteriorate or destroy PTC element.

2. Use this product within the specified temperature. A higher temperature may deteriorate the characteristic or material.

3. The body of this product is not insulated. Please keep an adequate distance to surrounding components and wiring.

---

### Attention:

This datasheet is downloaded from the website of Murata Manufacturing Co., Ltd.  
Therefore, it's specifications are subject to change or our products in it may be discontinued without advance notice.  
Please check with our sales representatives or product engineers before ordering.

4. Storage conditions

To keep solderability from declining, following storage condition is recommended.

- (1) Condition      Temperature : -10 to +40°C  
                         Humidity            : Less than 75%RH (not dewing condition)
- (2) Term: Please use this POSISTOR within 6 months after shipment by first-in and first-out stocking system.
- (3) Handling after seal open: After unpacking of the minimum package, reseal it promptly or store it inside a sealed container with a drying agent.
- (4) Place: Do not store this product in corrosive gas (SOx, Cl etc) or under sunlight.

5. Solder and Flux

(1) Solder Paste

Use Sn:Pb=60:40wt% , Sn:Pb=63:37wt% , Sn:Ag:Cu=96.5:3.0:0.5wt% or equivalent type of solder paste.

Do not use strong acidic flux (with halide content exceeding 0.2wt%).

Use of the solder containing Zn may reduce adhesive strength. When you use the solder containing Zn, please contact us in advance. For your reference, we are using '63Sn/37Pb RMA9086 90-3-M18', manufactured by Alpha Metals Japan Ltd., '96.5Sn/3.0Ag/0.5Cu M705-GRN360-K2-V', manufactured by Senju Metal Industry Co., LTD. for any Internal tests of this product.

(2) Flux

Use rosin type flux in soldering process.

If below flux is used, some problems might be caused in the product characteristics and reliability.

Please do not use below flux.

- Strong acidic flux (with halide content exceeding 0.2wt%).
- Water-soluble flux(\*Water-soluble flux can be defined as non rosin type flux including wash-type flux and non-wash-type flux.)

6. For removing the flux after soldering, observe the following points in order to avoid deterioration of the characteristics or any change of the external electrodes quality.

(1) Cleaning Conditions

| Solvent    | Dipping Cleaning  | Ultrasonic Cleaning  |
|------------|---|--|
| 2-propanol | Less than 5 min.<br>at room temp.<br>or<br>Less than 2 min.<br>at 40°C max. | Less than 1 min.<br>20W/L max.<br>Frequency of several 10 kHz<br>to several 100 kHz. |

A sufficient cleaning shall be applied to remove flux completely.

(2) Drying: After cleaning, dry promptly this product.

**Attention:**

This datasheet is downloaded from the website of Murata Manufacturing Co., Ltd. Therefore, it's specifications are subject to change or our products in it may be discontinued without advance notice. Please check with our sales representatives or product engineers before ordering.

7. In your mounting process, observe the following points in order to avoid deterioration of the characteristics or destruction of this product. The mounting quality of this product may also be affected by the mounting conditions, shown the points below.

This product is for only reflow soldering. Flow soldering shall not be allowed.

Please mount this product by soldering. When mounted by other methods, such as conductive adhesives, please contact us in advance.

(1) Standard Land Size

Too big land size gives too much solder paste on the land. It may cause destruction of this product, because of the mechanical stress especially in the case of board bending.

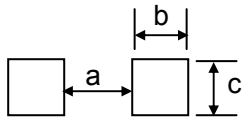

| Soldering Methods | Size(mm/inch) | a       | b       | c       |
|-------------------|---------------|---------|---------|---------|
| Flow Soldering    | 2012/0805     | 1.0~1.2 | 0.9~1.0 | 1.0~1.2 |
| Reflow Soldering  | 2012/0805     | 1.0~1.2 | 0.5~0.7 | 1.0~1.2 |
| Flow Soldering    | 1608/0603     | 0.6~1.0 | 0.8~0.9 | 0.6~0.8 |
| Reflow Soldering  | 1608/0603     | 0.6~0.8 | 0.6~0.7 | 0.6~0.8 |
| Reflow Soldering  | 1005/0402     | 0.5     | 0.4~0.5 | 0.5     |

(2) Printing Conditions of Solder Paste

i. Standard thickness of solder paste printing shall be from 0.10 to 0.15 mm.

ii. After soldering, the solder fillet shall be a height from 0.2 mm to the thickness of this product.

(See the figures below.)

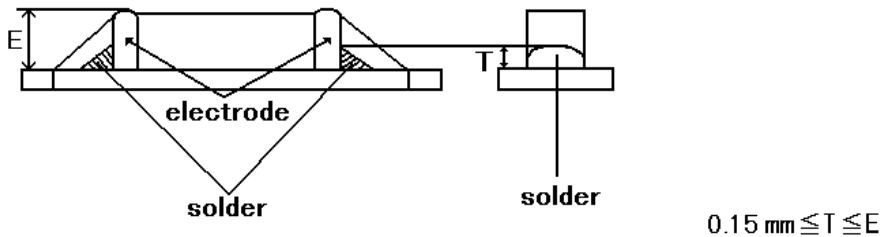

iii. Too much solder gives too strong mechanical stress to this product, such stress may cause cracking or any mechanical damage. And also, it can destroy the electrical performance of this product.

(3) Reflow soldering conditions

The following figure and table show our recommended reflow profile.

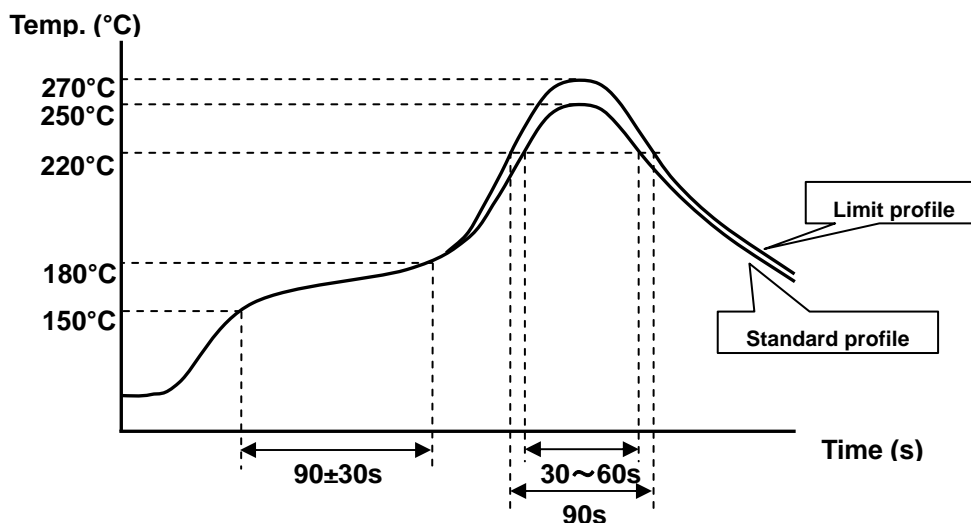

**Attention:**

This datasheet is downloaded from the website of Murata Manufacturing Co., Ltd. Therefore, its specifications are subject to change or our products in it may be discontinued without advance notice. Please check with our sales representatives or product engineers before ordering.

|                         | Standard profile  | Limit profile |
|-------------------------|-------------------|---------------|
| Preheat                 | 150~180°C, 90±30s |               |
| Soldering time (≥220°C) | 30~60s            | 90s           |
| Soldering time          | 20s(245°C)        | 45s(250°C)    |
| Peak temp.              | 250°C             | 270°C         |
| Reflow cycle            | Max. 2times       | Max. 2times   |

I. Insufficient preheating may cause a crack on ceramic body.

The temperature difference between preheat and peak should be control within 100°C to prevent this.

II. The excessive soldering conditions may cause dissolution of metallization or deterioration of solder-wetting on the external electrode.

III. Rapid cooling by dipping in solvent or by other means is not recommended.

IV. Please evaluate it on your condition if you will do mounting using not applying condition to the above-mentioned.

(5) There is a fear of unexpected failures (tombstone, insufficient solder-wetting, etc.) in your mounting process, caused by the mounting conditions. Please evaluate if this product is correctly mounted under your mounting conditions.

(6) Conditions with Soldering Iron

When hand soldering by iron is applied, be sure to keep following conditions.

| Item                    | Conditions  |
|-------------------------|---|
| Preheating              | at 150°C for 1 to 2 minute  |
| Temperature of Iron-tip | 350°C max.  |
| Soldering Iron Wattage  | 30W max.  |
| Diameter of Iron-tip    | 3mm dia. max.   |
| Soldering Time          | 5sec. max.  |
| Solder                  | H60A (Sn:Pb=60:40wt%) type ,<br>H63A (Sn:Pb=63:37wt%) type, Sn:Ag:Cu=96.5:3.0:0.5wt%<br>or equivalent type.   |
| Flux                    | Do not use strong acidic flux (with halide content exceeding 0.2wt%).   |
| Caution                 | Do not allow the iron-tip to directly touch the ceramic body.<br>Preheat the ceramic body and mounting board. |

8. Do not give this product a strong press-force nor a mechanical shock. Because such mechanical forces

may cause cracking or chipping of this ceramic product.

9. Rapid cooling or heating during soldering is not recommended.

Such treatment may destroy the element.

10. Resin coating

Please select the resin of which hardness shrinkage is much less, on selecting a resin materials.

**Attention:**

This datasheet is downloaded from the website of Murata Manufacturing Co., Ltd.  
Therefore, it's specifications are subject to change or our products in it may be discontinued without advance notice.  
Please check with our sales representatives or product engineers before ordering.

11. Location on Printed Circuit Board(PC Board)

<Component Direction>  
Locate this product horizontal to the direction in which stress acts.

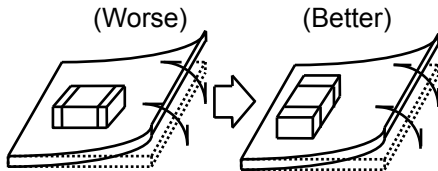

<Mounting Close to Board Separation Line>  
Put this product on the PC Board near the Slit, not near the Perforation Holes.  
Keep this product on the PC Board away from the Separation Line.

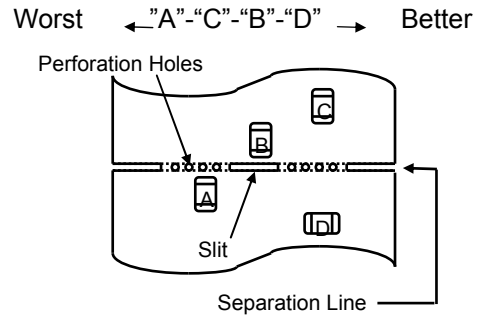

**Note**

1. Please make sure that your product has been evaluated in view of your specifications with our product being mounted to your product.
2. You are requested not to use our product deviating from the agreed specifications.
3. We consider it not appropriate to include any terms and condition with regard to the business transaction in the product specification, drawings or other technical documents. Therefore, if your technical documents as above include such terms and conditions such as warranty clause, product liability clause, intellectual property infringement liability clause, or export control clause, they will be deemed to be invalid.

**Attention:**

This datasheet is downloaded from the website of Murata Manufacturing Co., Ltd. Therefore, it's specifications are subject to change or our products in it may be discontinued without advance notice. Please check with our sales representatives or product engineers before ordering.



## X-ON Electronics

Largest Supplier of Electrical and Electronic Components

*Click to view similar products for [PTC \(Positive Temperature Coefficient\) Thermistors](#) category:*

*Click to view products by [Murata](#) manufacturer:*

Other Similar products are found below :

[PTCAUX7-36-5C](#) [PTCCL09H251FBE](#) [PTCTL3MR100GTE](#) [PTCCL05H630HTE](#) [B59346A1502P020](#) [PTCTT95R100GTE](#)  
[PTCLL05P131TBE](#) [PTCCL09H541DBE](#) [TFPT0805L1800FV](#) [B59725T1120A062](#) [B59116S0225B010](#) [B59008C0150A040](#)  
[B59100M1090A070](#) [B59100M1145A070](#) [B59873C0120A070](#) [102PS1G](#) [B59300M1150A070](#) [B59339A1501P020](#) [B59770B0120A070](#)  
[B59995C0120A070](#) [YQR100R060](#) [YQS5751PTO](#) [YQS5856PTF](#) [YQS5930PTO](#) [YS5675](#) [YS5918PTO](#) [YQS5898PTO](#) [YQS5868PTF](#)  
[YQD100N1000](#) [KTY81/210,112](#) [B59010D1135B40](#) [B59606A110A62](#) [B59807A90A62](#) [B59830C120A70](#) [B59874C120A70](#)  
[B59960C160A70](#) [YQD120N0025](#) [PTGL12AR270M9C01B0](#) [PTGL12AR100M6C01B0](#) [PTGL07AS2R7K2B51A0](#) [PTGL07AS1R8K2B51B0](#)  
[PTS120601B100RPU00](#) [PTGL10AR3R9M3P51B0](#) [PTGL07BD220N3B51B0](#) [PTGL07AS5R6K4B51B0](#) [PTGL07AS150K6B51A0](#)  
[PTGL07AR8R2M3P51B0](#) [PTGL07AR560M9A51B0](#) [PTGL04AS220K4N51B0](#) [PTFL04BD471Q2N34B0](#)