

Typical unit

Output (Vout, max)	Current (A)	Nominal Input (V)
11.85	33	48

### FEATURES

- 391 Watts total output power, 11.85 VDC @ 33 A
- Regulated Intermediated Bus Architecture (RIBA) with PoL converters
- 96% ultra-high efficiency at full load (typical)
- 36 to 75 Volt DC input range (48 VDC nominal)
- Standard quarter-brick footprint
- Synchronous rectifier topology with 100 mV ripple & noise
- Up to +85° Celsius thermal performance (with derating)
- Stable no-load operation
- Multiple-unit parallel operation for increased current
- Fully isolated to 2250 VDC (BASIC)
- Remote On/Off enable control
- Extensive protection features – SC, OC, UVLO, OT
- Certified to full safety, emissions and environmental standards
- Meets UL 60950-1, CAN/CSAC22.2 No. 60950-1, IEC60950-1, EN60950-1 safety approvals (2nd Edition)

### PRODUCT OVERVIEW

The fully isolated (2250 Vdc) RBQ-12/33-D48 module accepts a 36 to 75 Volt DC input voltage range (48 VDC nominal) and converts it to a low Vdc output. Applications include 48V-powered datacom and telecom installations, base stations, cellular dataphone repeaters, instruments and embedded systems. Wideband output ripple and noise is a low 100 mV, peak-to-peak.

The RBQ's synchronous-rectifier topology with line regulation and fixed frequency operation means excellent efficiencies up to 96%, enabling “no heatsink” operation for most applications up to +85° Celsius (with derating airflow). “No fan” or

zero airflow higher temperature applications may use the optional base plate for cold surface mounting or natural-convection heatsinks.

A wealth of electronic protection features include input undervoltage lockout (UVLO), output current limit, short circuit hiccup, and overtemperature shutdown. Available options include positive or negative logic remote On/Off control, conformal coating, various pin lengths, and the baseplate. Assembled using ISO-certified automated surface-mount techniques, the RBQ series is certified to all UL and IEC emissions, safety and flammability standards.

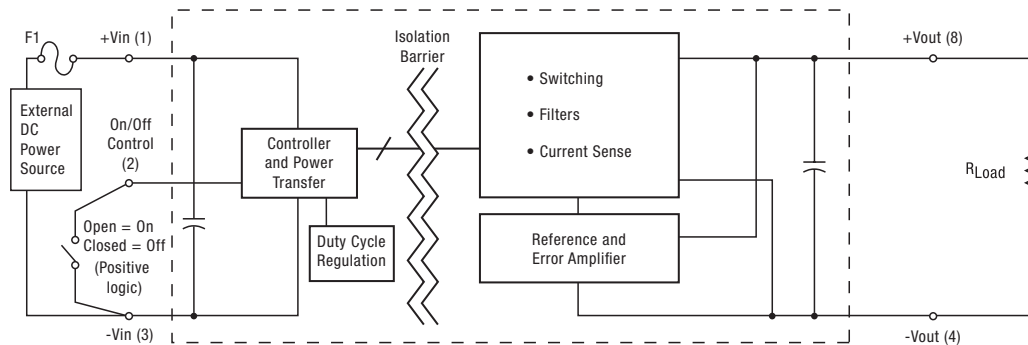

Figure 1. Connection Diagram

Typical topology is shown. Murata Power Solutions recommends an external fuse at F1.



### PERFORMANCE SPECIFICATIONS SUMMARY AND ORDERING GUIDE

Root Model ①	Output						Input				Efficiency	Dimensions (baseplate)		
	V <sub>OUT</sub> (V, max)	I <sub>OUT</sub> (A, max)	Total Power (W, max)	Ripple & Noise (mVp-p)		Regulation (max.) ②		V <sub>IN</sub> Nom. (V)	Range (V)	I <sub>IN</sub> , min. load (mA)		I <sub>IN</sub> , full load (A)	Typ.	(inches)
				Typ.	Max.	Line (%)	Load (%)							
RBQ-12/33-D48	11.85	33	391	100	200	+1/-2	±3	48	36-75	140	8.59	96%	2.3 x 1.45 x 0.5	58.4 x 36.8 x 12.7

- ① Please refer to the part number structure for additional options and complete ordering part numbers.
- ② Regulation specifications describe the output voltage deviations as the line voltage or load current is varied from its nominal/midpoint value to either extreme. (Load step = ±25 %). Line Regulation tested from 40V to 75V, output @nominal load.

- ③ All specifications are at nominal line voltage and full load, +25 deg.C. unless otherwise noted. See detailed specifications. Output capacitors are 1µF, 10µF and 470µF in parallel, with a 220µF input capacitor. I/O caps are necessary for our test equipment and may not be needed for your application.

### PART NUMBER STRUCTURE

**RB Q - 12 / 33 - D48 N B S H Lx - C**

**Output Configuration**

RB = Regulated Converter

**Quarter-Brick Package**

Isolated converter

**Maximum Output Voltage (11.85V)**

**Maximum Rated Output**

Current in Amps

**Input Voltage Range**

D48 = 36-75V,  
48V nominal

**On/Off Control Logic Option**

N = Negative logic  
P = Positive logic

**Baseplate**

B = Baseplate installed, standard

**Load Share Option**

Blank = no share  
S = Load share

**Conformal coating (optional)**

Blank = no coating, standard  
H = Coating added, optional\*

**Pin Length Option (Through-hole packages only)**

Blank = Standard pin length 0.180 inches (4.6mm)  
L1 = Pin length 0.110 inches (2.79mm)\*  
L2 = Pin length 0.145 inches (3.68mm)\*

**RoHS Hazardous Materials compliance**

C = RoHS 6 (does not claim EU RoHS exemption 7b-lead in solder), standard

\*Special quantity order is required; no sample quantities available.

Note: Some model number combinations may not be available. Please contact Murata Power Solutions for ordering assistance.

### FUNCTIONAL SPECIFICATIONS

ABSOLUTE MAXIMUM RATINGS	Conditions ①	Minimum	Typical/Nominal	Maximum	Units
Input Voltage, Continuous	Full power operation	0		80	Vdc
Input Voltage, Transient	Operating or non-operating, 100 mS max. duration	0		100	Vdc
Isolation Voltage	Input to output, 100 mS to IEC/EN/UL 60950-1			2250	Vdc
On/Off Remote Control	Power on or off, referred to -Vin	0		15	Vdc
Output Power		0		391	W
Output Current	Current-limited, no damage, short-circuit protected	0		33	A
Storage Temperature Range	Vin = Zero (no power)	-55		125	°C

Absolute maximums are stress ratings. Exposure of devices to greater than any of these conditions may adversely affect long-term reliability. Proper operation under conditions other than those listed in the Performance/Functional Specifications Table is not implied or recommended.

INPUT					
Operating voltage range		36	48	75	Vdc
Recommended External Fuse	Fast blow		20		A
Start-up threshold	Rising input voltage	32	33.5	35	Vdc
Undervoltage shutdown	Falling input voltage	30	31.5	33	Vdc
Internal Filter Type			Pi		
Input current					
Full Load Conditions			8.59	8.68	A
Low Line	Vin = minimum		10.8	12	A
Inrush Transient				0.3	A2-Sec.
Output in Short Circuit				0.5	A
No Load Input Current (Iout @ min)	Iout = minimum, unit=ON		140	200	mA
Shut-Down Mode Input Current			5	10	mA
Reflected (back) ripple current ②	Measured at input with specified filter		70	200	mA, RMS

GENERAL and SAFETY					
Efficiency	Vin=48V, full load	95	96		%
	Vin=75V, full load	93	94		%
Isolation					
Isolation Voltage, input to output	No baseplate	2250			Vdc
Isolation Voltage, input to output	With baseplate	2250			Vdc
Isolation Voltage, input to baseplate	With baseplate	1500			Vdc
Isolation Voltage, output to baseplate	With baseplate	1500			Vdc
Insulation Safety Rating			basic		
Isolation Resistance			10		Mohm
Isolation Capacitance			1500		pF
Safety	Certified to UL-60950-1, CSA-C22.2 No.60950-1, IEC/EN60950-1, 2nd edition		Yes		
Calculated MTBF	Per Telcordia SR332, issue 1, class 3, ground fixed, Tambient=+25°C		1.8		Hours x 10 <sup>6</sup>

DYNAMIC CHARACTERISTICS					
Fixed Switching Frequency			360		KHz
Startup Delay	Power On to Vout regulated, 10-90% Vout, resistive load			20	mS
Startup Delay	Remote ON to 10% of Vout			10	mS
Dynamic Load Response	50-75-50% load step, settling time to within ±2% of Vout			350	µSec
Dynamic Load Peak Deviation	Same as above			±400	mV

FEATURES and OPTIONS					
Remote On/Off Control ④					
"N" suffix:					
Negative Logic, ON state	ON = Pin grounded or external voltage	-0.1		0.8	V
Negative Logic, OFF state	OFF = Pin open or external voltage	3.5		15	V
Control Current	Open collector/drain		1	2	mA
"P" suffix:					
Positive Logic, ON state	ON = Pin open or external voltage	2.5		15	V
Positive Logic, OFF state	OFF = Ground pin or external voltage	0		1	V
Control Current	Open collector/drain		1	2	mA

### FUNCTIONAL SPECIFICATIONS (CONT.)

OUTPUT	Conditions ①	Minimum	Typical/Nominal	Maximum	Units
<b>Total Output Power</b>	See Derating	0	386	391	W
<b>Voltage</b>					
<b>Nominal Output Voltage</b>	Measured @ 48Vin, Half Load.	11.5	11.7	11.85	Vdc
<b>Total Output Range</b>	Over sample load (0-33A), input line (40-75V) and temperature (see derating curves) , for regular model and S option	11		12.5	V
<b>Vout Overshoot</b>		12.9		13.1	V
<b>Voltage</b>					
<b>Output Voltage (initial output set point @48V, no load)</b>	For S option only	11.7		12.5	Vdc
<b>Output Voltage (initial output set point @48V, 50% load)</b>	For S option only	11.69		11.71	Vdc
<b>Output Voltage (initial output set point @48V, 100% load)</b>	For S option only	11.5		11.7	Vdc
<b>Output Voltage</b>	For S option only	11.5	11.7	12.5	Vdc
<b>Overvoltage Protection</b>	Output Voltage clamped (see technical note)		N/A		V
<b>Current</b>					
<b>Output Current Range</b>		0	33	33	A
<b>Minimum Load</b>			No minimum load		
<b>Current Limit Inception</b>	98% of Vnom., after warmup	40	46	50	A
<b>Short Circuit</b>					
<b>Short Circuit Current</b>	Hiccup technique, autorecovery within 1.25% of Vout			6	A
<b>Short Circuit Duration (remove short for recovery)</b>	Output shorted to ground, no damage		Continuous		
<b>Short circuit protection method</b>	Current limiting				
<b>Regulation ⑤</b>					
<b>Line Regulation</b>	Vin=40 to 75V			+1/-2	%
<b>Load Regulation</b>	Iout=min. to max., Vin=48V			±3	%
<b>Ripple and Noise</b>	5 Hz- 20 MHz BW		100	200	mV pk-pk
<b>Temperature Coefficient</b>	At all outputs		0.003	0.02	% of Vnom./°C
<b>Maximum Capacitive Loading (10% ceramic, 90% Oscon)</b>	Cap. ESR=<0.02Ω, Full resistive load	470		6000	μF
<b>MECHANICAL (Through Hole Models)</b>					
<b>Outline Dimensions (with baseplate)</b>			2.3 x 1.45 x 0.5		Inches
			58.4 x 36.8 x 12.7		mm
<b>Weight (with baseplate)</b>			2.4		Ounces
			69		Grams
<b>Through Hole Pin Diameter</b>	Input pins		0.04 ±0.001		Inches
			1.016±0.025		mm
<b>Through Hole Pin Diameter</b>	Output pins		0.060 ±0.001		Inches
			1.524±0.025		mm
<b>Through Hole Pin Material</b>			Copper alloy		
<b>TH Pin Plating Metal and Thickness</b>	Nickel subplate		100-299		μ-inches
	Gold overplate		3.9-20		μ-inches
<b>ENVIRONMENTAL</b>					
<b>Operating Ambient Temperature Range</b>	With derating, full power, no condensation, components +125°C. max.	-40		85	°C
<b>Storage Temperature</b>	Vin = Zero (no power)	-55		125	°C
<b>Thermal Protection/Shutdown</b>	Measured at hotspot	115	125	130	°C
	Operating baseplate temperature	-40	110	120	°C
<b>Electromagnetic Interference Conducted, EN55022/CISPR22</b>	External filter is required		B		Class
<b>Relative humidity, non-condensing</b>	To +85°C	10		90	%RH
<b>Altitude</b>	must derate -1%/1000 feet	-500		10,000	feet
		-152		3048	meters
<b>RoHS rating</b>			RoHS-6		

### Notes

① Unless otherwise noted, all specifications are at nominal input voltage, nominal output voltage and full load. General conditions are +25° Celsius ambient temperature, near sea level altitude, natural convection airflow. All models are tested and specified with external parallel 1μF, 10μF and 470 μF output capacitors and 220 μF external input capacitor. All capacitors are low-ESR types wired close to the converter. These capacitors are necessary for our test equipment and may not be needed in the user's application.

- ② Input (back) ripple current is tested and specified over 5 Hz to 20 MHz bandwidth. Input filtering is Cbus = 220 μF, Cin = 220 μF and Lbus = 4.7 μH.
- ③ All models are stable and regulate to specification under no load.
- ④ The Remote On/Off Control is referred to -Vin.
- ⑤ Regulation specifications describe the output voltage changes as the line voltage or load current is varied from its nominal or midpoint value to either extreme.

**PERFORMANCE DATA**

Efficiency and Power Dissipation

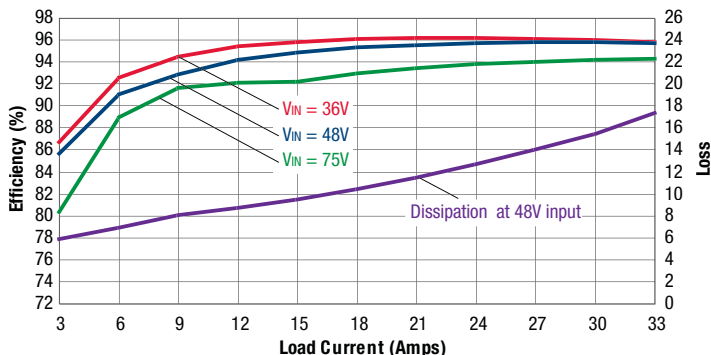

Current Sharing\*  
Ta=25°C, Vin=48V

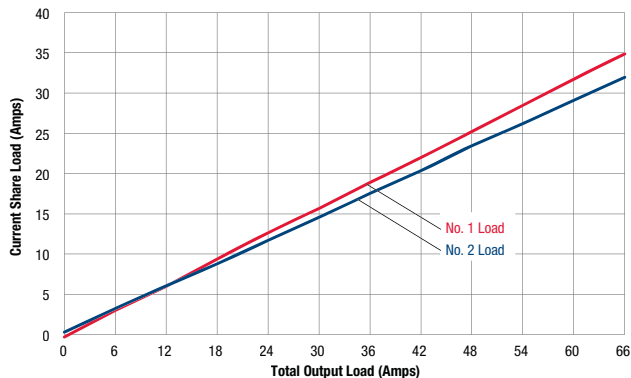

\*See Technical note section

Startup Delay (Vin = 48V, Iout = 33A, Vout = nom, Load = 470µF, Ta = +25°C)  
Ch1 = Vin, Ch2 = Vout

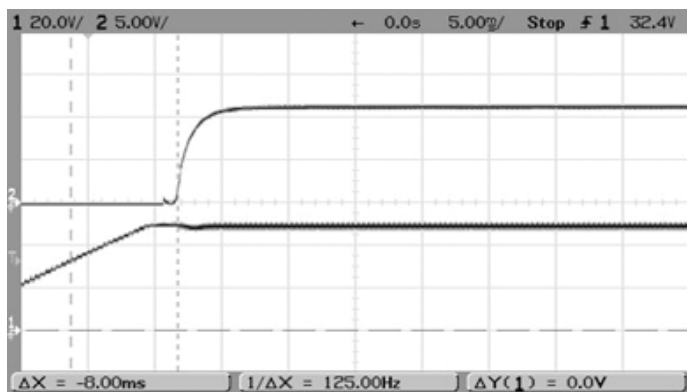

Enable Startup Delay (Vin = 48V, Iout = 33A, Vout = nom, Load = 470µF, Ta = +25°C)  
Ch2 = Vout, Ch4 = Enable

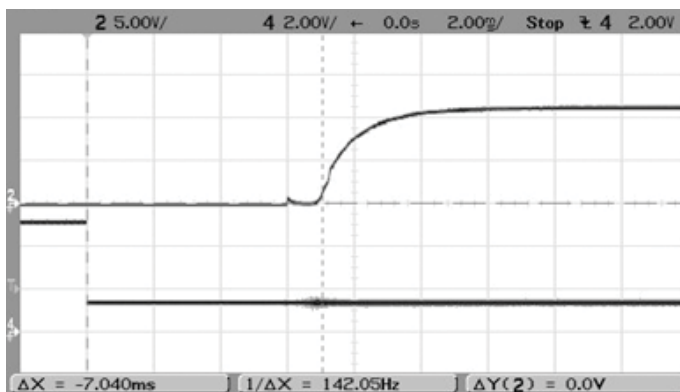

Output ripple and Noise (Vin = 48V, Iout = 0A, Vout = nom, Load = 1µF || 10µF || 470µF, Ta = +25°C)

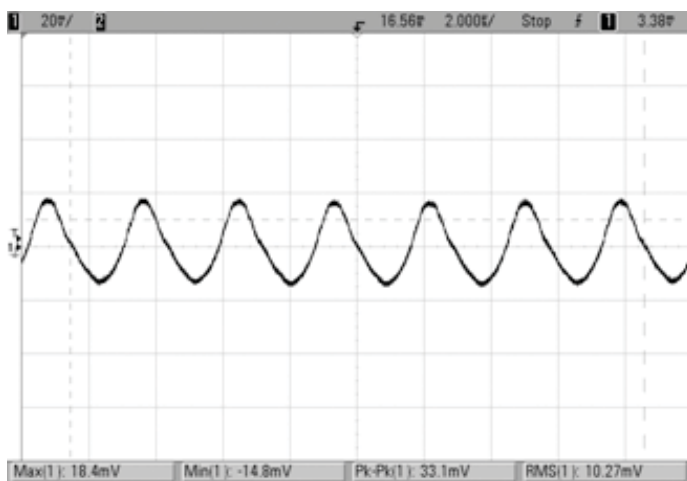

Output ripple and Noise (Vin = 48V, Iout = 33A, Vout = nom, Load = 1µF || 10µF || 470µF, Ta = +25°C)

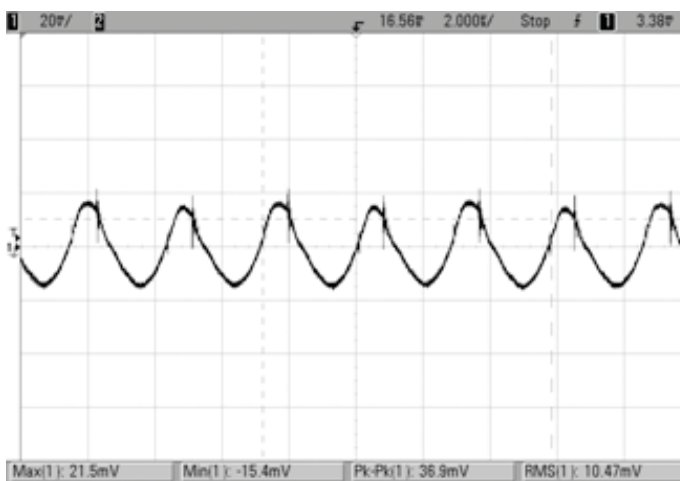

**PERFORMANCE DATA**

Step Load Transient Response ( $V_{in} = 48V$ ,  $I_{out} = 50\text{-}75\%$  of  $I_{max}$ ,  $C_{load} = 470\mu F$ , Slew rate:  $1A/uS$ ,  $T_a = +25\text{ }^\circ C$ .) (-Delta =  $278mV$ , Recovery Time =  $164\mu S$ )

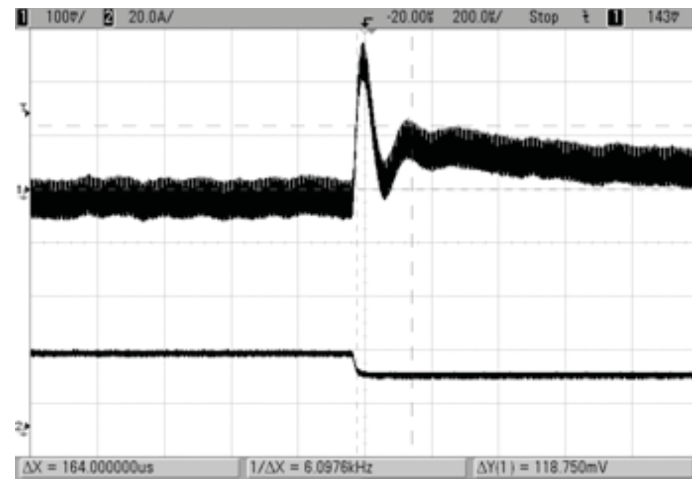

Step Load Transient Response ( $V_{in} = 48V$ ,  $I_{out} = 75\text{-}50\%$  of  $I_{max}$ ,  $C_{load} = 470\mu F$ , Slew rate:  $1A/uS$ ,  $T_a = +25\text{ }^\circ C$ .) (-Delta =  $266mV$ , Recovery Time =  $156\mu S$ )

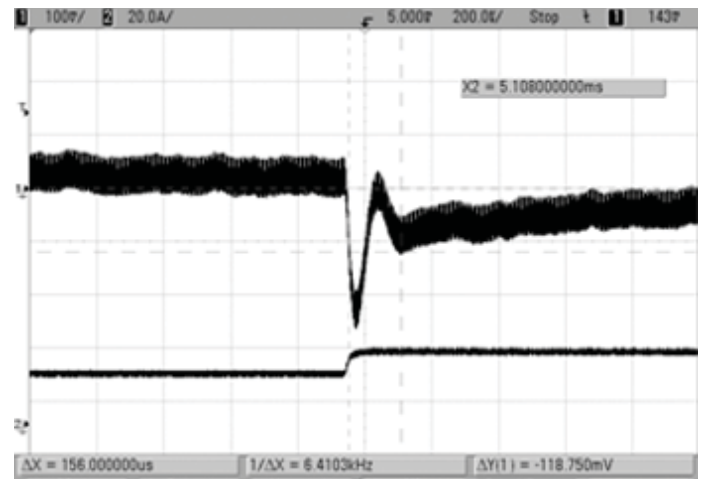

Step Load Transient Response ( $V_{in} = 48V$ ,  $I_{out} = 50\text{-}75\text{-}50\%$  of  $I_{max}$ ,  $C_{load} = 470\mu F$ , Slew rate:  $1A/uS$ ,  $T_a = +25\text{ }^\circ C$ .)

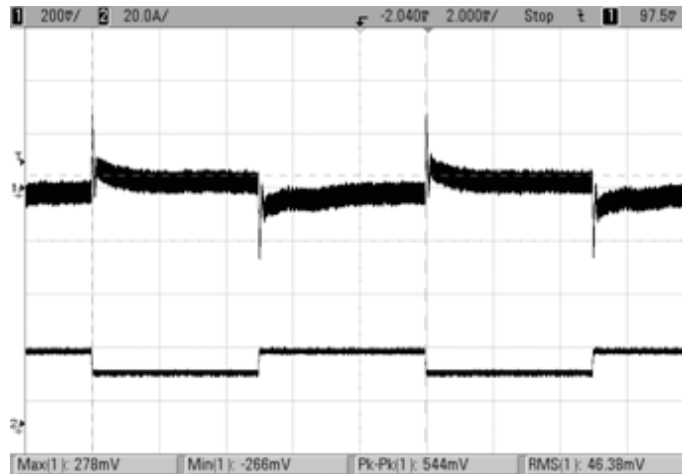

**PERFORMANCE DATA**

Maximum Current Temperature Derating in Transverse Direction  
Vin= 40V (air flow is from -Vin to +Vin), with baseplate

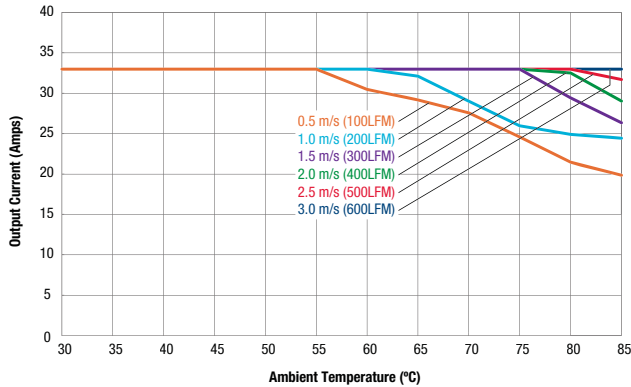

Maximum Current Temperature Derating in Longitudinal Direction  
Vin= 40V (air flow is from Vin to Vout), with baseplate

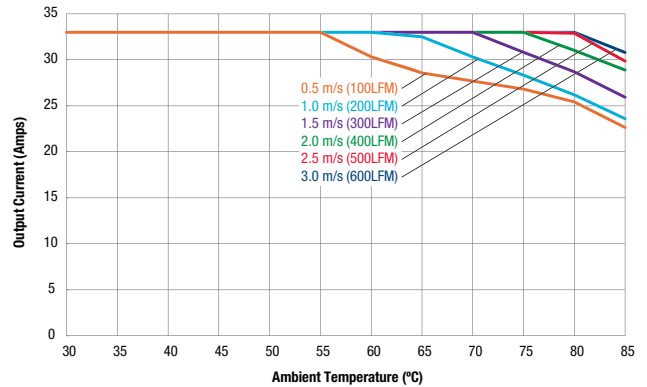

Maximum Current Temperature Derating in Transverse Direction  
Vin= 48V (air flow is from -Vin to +Vin), with baseplate

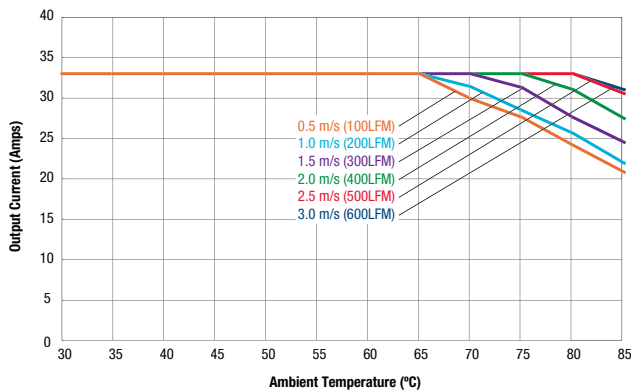

Maximum Current Temperature Derating in Longitudinal Direction  
Vin= 48V (air flow is from Vin to Vout), with baseplate

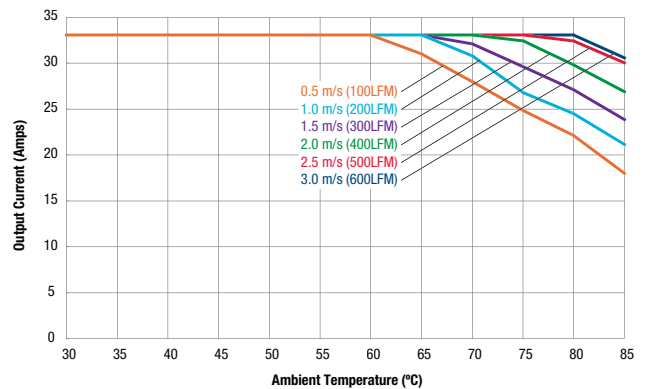

Maximum Current Temperature Derating in Transverse Direction  
Vin= 75V (air flow is from -Vin to +Vin), with baseplate

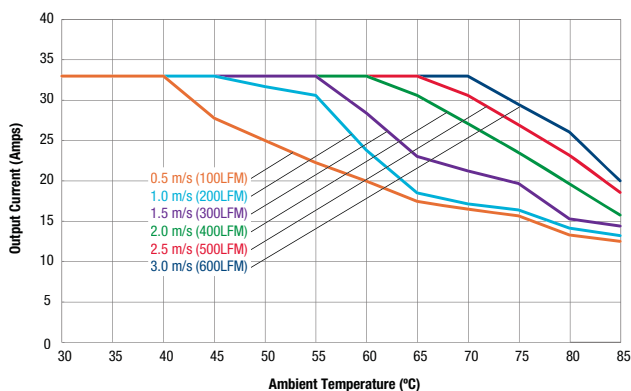

Maximum Current Temperature Derating in Longitudinal Direction  
Vin= 75V (air flow is from Vin to Vout), with baseplate

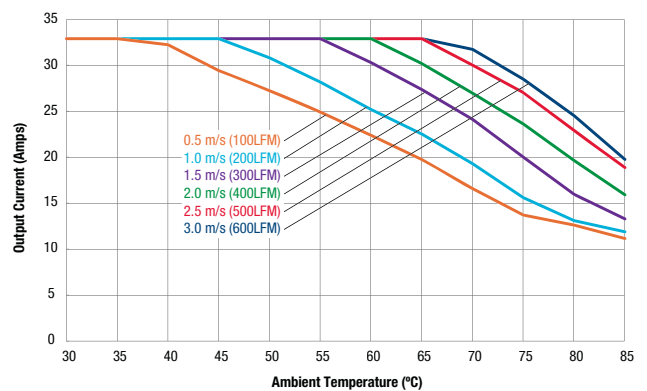

**MECHANICAL SPECIFICATIONS (THROUGH-HOLE MOUNT)**

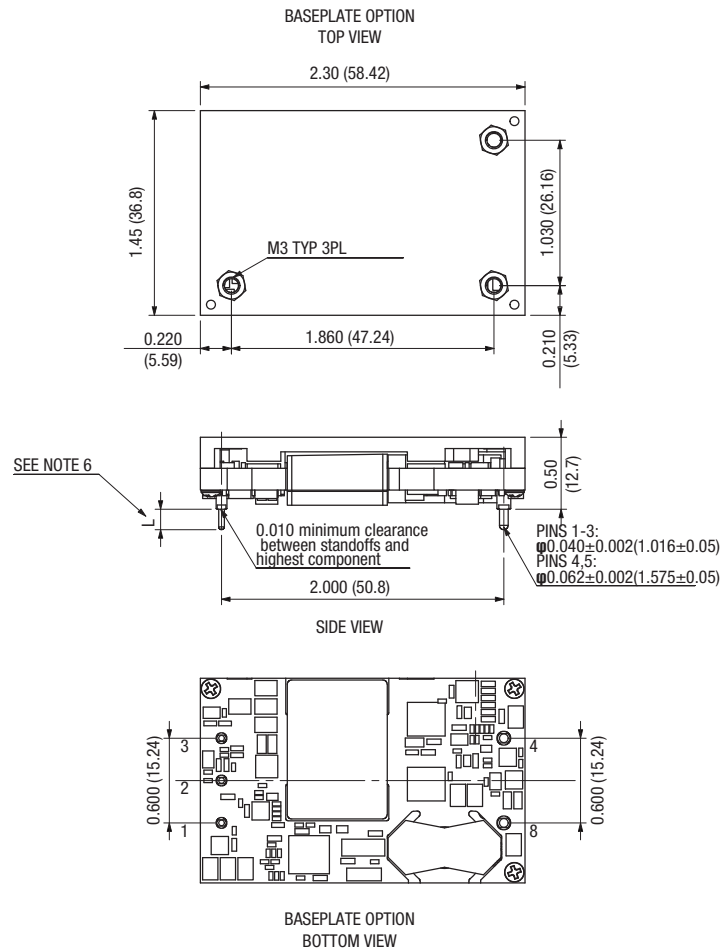

- NOTES:  
 UNLESS OTHERWISE SPECIFIED:  
 1:M3 SCREW USED TO BOLT UNIT'S BASEPLATE TO OTHER SURFACES(SUCH AS HEATSINK)  
 MUST NOT EXCEED 0.098"(2.5mm) DEPTH BELOW THE SURFACE OF BASEPLATE  
 2:APPLIED TORQUE PER SCREW SHOULD NOT EXCEED 5.3In-lb(0.6Nm);  
 3:ALL DIMENSION ARE IN INCHES(MILLIMETER);  
 4:ALL TOLERANCES: x.x×in, ±0.02in(x.xmm,±0.5mm)  
 x.x××in, ±0.01in(x.x×mm,±0.25mm)  
 5:COMPONENT WILL VARY BETWEEN MODELS  
 6:STANDARD PIN LENGTH: 0.180 Inch  
 FOR L2 PIN LENGTH OPTION IN MODEL NAME, SEE PART NUMBER STRUCTURE.

Dimensions are in inches (mm shown for ref. only).

INPUT/OUTPUT CONNECTIONS	
Pin	Function
1	+Vin
2	Remote On/Off
3	-Vin
4	-Vout
8	+Vout

The 0.145" (L2) pin length is shown.  
 Please refer to the part number structure for alternate pin lengths.

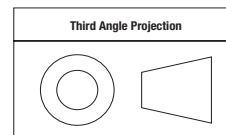

Tolerances (unless otherwise specified):  
 .XX ± 0.02 (0.5)  
 .XXX ± 0.010 (0.25)  
 Angles ± 2°

Components are shown for reference only and may vary between units.



**SHIPPING TRAYS AND BOXES, THROUGH-HOLE MOUNT**

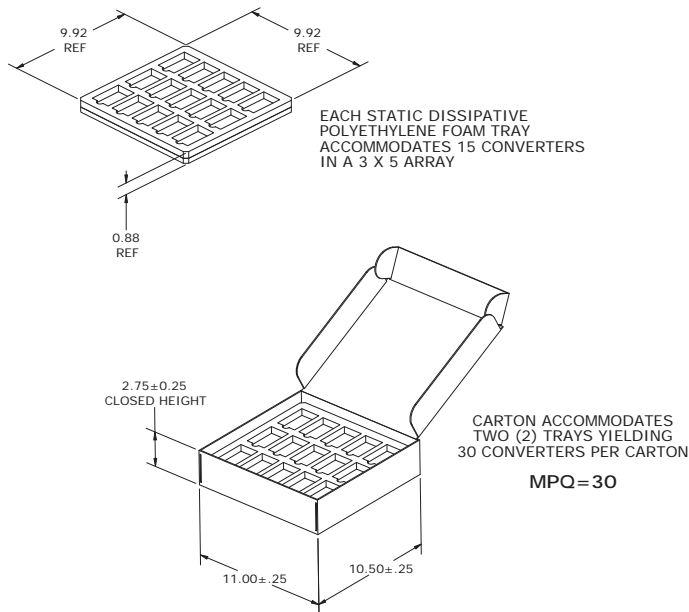

**SHIPPING TRAY DIMENSIONS**

RBQ modules are supplied in a 15-piece (5 x 3) shipping tray. The tray is an anti-static closed-cell polyethylene foam. Dimensions are shown below.

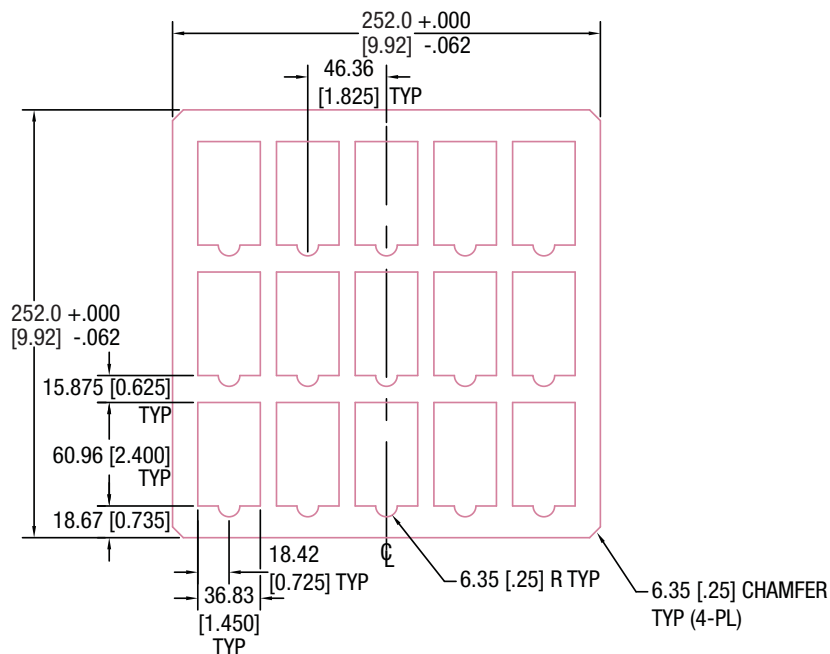

- Notes:
1. Material: Dow 220 antistat ethafoam (Density: 34-35 kg/m<sup>3</sup>)
  2. Dimensions: 252 x 252 x 19.1 mm 5 x 3 array (15 per tray)
  3. All dimensions in millimeters [inches]
  4. Tolerances unless otherwise specified: +1/-0

**TECHNICAL NOTES**

**Thermal Shutdown**

Extended operation at excessive temperature will initiate overtemperature shutdown triggered by a temperature sensor inside the PWM controller. This operates similarly to overcurrent and short circuit mode. The inception point of the overtemperature condition depends on the average power delivered, the ambient temperature and the extent of forced cooling airflow. Thermal shutdown uses only the hiccup mode (autorestart).

**Parallel Load Sharing (S Option, Load Sharing)**

Two or more converters may be connected in parallel at both the input and output terminals to support higher output current (total power, see figure 2) or to improve reliability due to the reduced stress that results when the modules are operating below their rated limits. For applications requiring current share, follow the guidelines below. See specification table for Output Voltage set points. The stated output voltage set point is trimmed to a very narrow range ( $11.7V \pm 10mV @ 48Vin, 50\%$  load). The output voltage will decrease when the load current is increased. Our goal is to have each converter contribute nearly identical current into the output load under all input, environmental and load conditions.

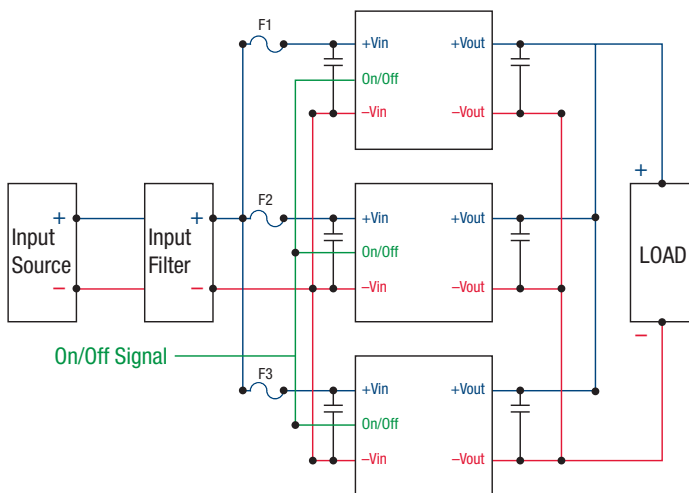

Figure 2. Load Sharing Block Diagram

**Using Parallel Connections – Load Sharing (Power Boost)**

- All converters must be powered up and powered down simultaneously. Use a common input power source.
- It is required to use a common Remote On/Off logic control signal to turn on modules (see figure 2).
- When Vin has reached steady state, apply control signal to the all modules. Figure 3 illustrates the turn on process for positive logic modules.
- First power up the parallel system (all converters) with a load not exceeding the rated load of each converter and allow converters to settle (typically 20-100mS) before applying full load. As a practical matter, if the loads are downstream PoL converters, power these up shortly after the converter has reached steady state output. Also be aware of the delay caused by charging up external bypass capacitors.
- It is critical that the PCB layout incorporates identical connections from each module to the load; use the same trace rating and airflow/thermal environments. If you add input filter components, use identical components and layout.
- When converters are connected in parallel, allow for a safety factor of at least 10%. Up to 90% of max output current can be used from each module.

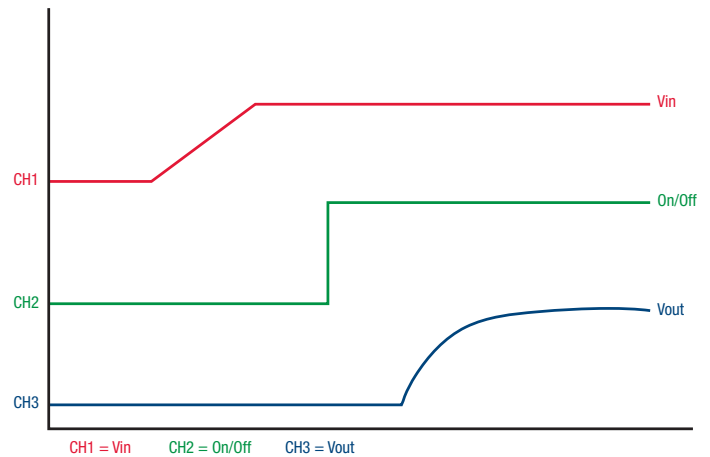

Figure 3. Typical Turn On for Positive Logic Modules

**CAUTION:** This converter is not internally fused. To avoid danger to persons or equipment and to retain safety certification, the user must connect an external fast-blow input fuse as listed in the specifications. Be sure that the PC board pad area and etch size are adequate to provide enough current so that the fuse will blow with an overload.

**Using Parallel Connections – Redundancy (N+1)**

The redundancy connections in figure 4 requires external user supplied “OR”ing diodes or “OR”ing MOSFETs for reliability purposes. The diodes allow for an uninterruptable power system operation in case of a catastrophic failure (shorted output) by one of the converters.

The diodes should be identical part numbers to enhance balance between the converters. The default factory nominal voltage should be sufficiently matched between converters. The OR’ing diode system is the responsibility of the user. Be aware of the power levels applied to the diodes and possible heat sink requirements.

Schottky power diodes with approximately 0.3V drops or “OR”ing MOSFETs may be suitable in the loop whereas 0.7 V silicon power diodes may not be advisable. In the event of an internal device fault or failure of the mains power

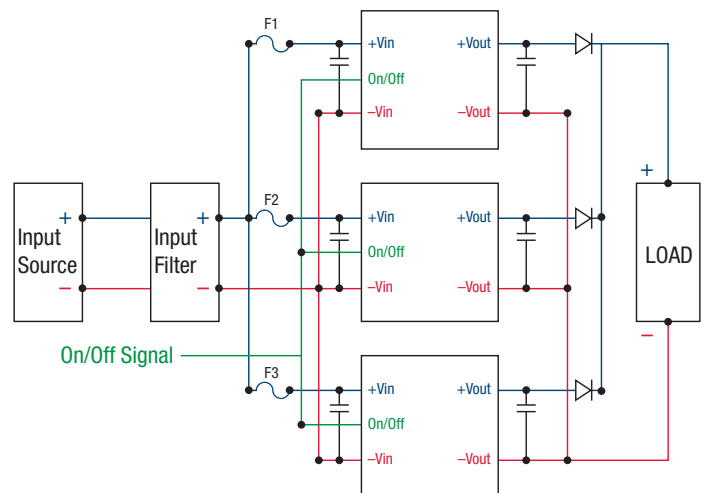

Figure 4. Redundant Parallel Connections

modules on the primary side, the other devices automatically take over the entire supply of the loads. In the basic N+1 power system, the “N” equals the number of modules required to fully power the system and “+1” equals one back-up module that will take over for a failed module. If the system consists of two power modules, each providing 50% of the total load power under normal operation and one module fails, another one delivers full power to the load. This means you can use smaller and less expensive power converters as the redundant elements, while achieving the goal of increased availability.

**Start Up Considerations**

When power is first applied to the DC-DC converter, there is some risk of start up difficulties if you do not have both low AC and DC impedance and adequate regulation of the input source. Make sure that your source supply does not allow the instantaneous input voltage to go below the minimum voltage at all times.

Use a moderate size capacitor very close to the input terminals. You may need two or more parallel capacitors. A larger electrolytic or ceramic cap supplies the surge current and a smaller parallel low-ESR ceramic cap gives low AC impedance.

Remember that the input current is carried both by the wiring and the ground plane return. Make sure the ground plane uses adequate thickness copper. Run additional bus wire if necessary.

**Input Fusing**

Certain applications and/or safety agencies may require fuses at the inputs of power conversion components. Fuses should also be used when there is the possibility of sustained input voltage reversal which is not current-limited. For greatest safety, we recommend a fast blow fuse installed in the ungrounded input supply line.

**Input Under-Voltage Shutdown and Start-Up Threshold**

Under normal start-up conditions, converters will not begin to regulate properly until the rising input voltage exceeds and remains at the Start-Up Threshold Voltage (see Specifications). Once operating, converters will not turn off until the input voltage drops below the Under-Voltage Shutdown Limit. Subsequent restart will not occur until the input voltage rises again above the Start-Up Threshold. This built-in hysteresis prevents any unstable on/off operation at a single input voltage.

**Start-Up Time**

Assuming that the output current is set at the rated maximum, the Vin to Vout Start-Up Time (see Specifications) is the time interval between the point when the rising input voltage crosses the Start-Up Threshold and the fully loaded output voltage enters and remains within its specified accuracy band. Actual measured times will vary with input source impedance, external input capacitance, input voltage slew rate and final value of the input voltage as it appears at the converter.

These converters include a soft start circuit to moderate the duty cycle of its PWM controller at power up, thereby limiting the input inrush current.

The On/Off Remote Control interval from On command to Vout (final  $\pm 5\%$ ) assumes that the converter already has its input voltage stabilized above the Start-Up Threshold before the On command. The interval is measured from the On command until the output enters and remains within its specified accuracy band. The specification assumes that the output is fully loaded at maximum

rated current. Similar conditions apply to the On to Vout regulated specification such as external load capacitance and soft start circuitry.

**Recommended Input Filtering**

The user must assure that the input source has low AC impedance to provide dynamic stability and that the input supply has little or no inductive content, including long distributed wiring to a remote power supply. The converter will operate with no additional external capacitance if these conditions are met.

For best performance, we recommend installing a low-ESR capacitor immediately adjacent to the converter’s input terminals. The capacitor should be a ceramic type such as the Murata GRM32 series or a polymer type. Make sure that the input terminals do not go below the undervoltage shutdown voltage at all times. More input bulk capacitance may be added in parallel (either electrolytic or tantalum) if needed.

**Recommended Output Filtering**

The converter will achieve its rated output ripple and noise with no additional external capacitor. However, the user may install more external output capacitance to reduce the ripple even further or for improved dynamic response. Again, use low-ESR ceramic (Murata GRM32 series) or polymer capacitors. Mount these close to the converter. Measure the output ripple under your load conditions.

Use only as much capacitance as required to achieve your ripple and noise objectives. Excessive capacitance can make step load recovery sluggish or possibly introduce instability. Do not exceed the maximum rated output capacitance listed in the specifications.

**Input Ripple Current and Output Noise**

All models in this converter series are tested and specified for input reflected ripple current and output noise using designated external input/output components, circuits and layout as shown in the figures below. The Cbus and Lbus components simulate a typical DC voltage bus.

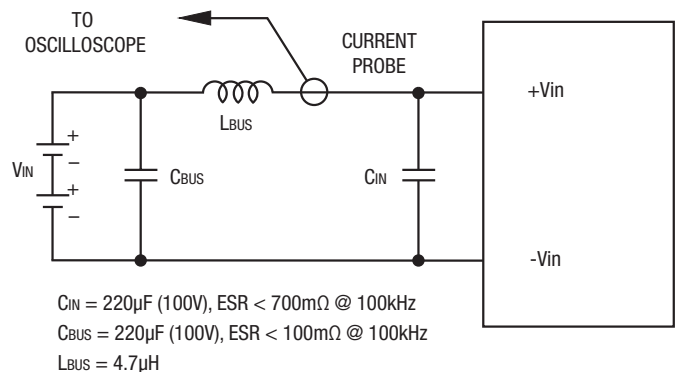

Figure 5. Measuring Input Ripple Current

**Minimum Output Loading Requirements**

All models regulate within specification and are stable under no load to full load conditions. Operation under no load might however slightly increase output ripple and noise.

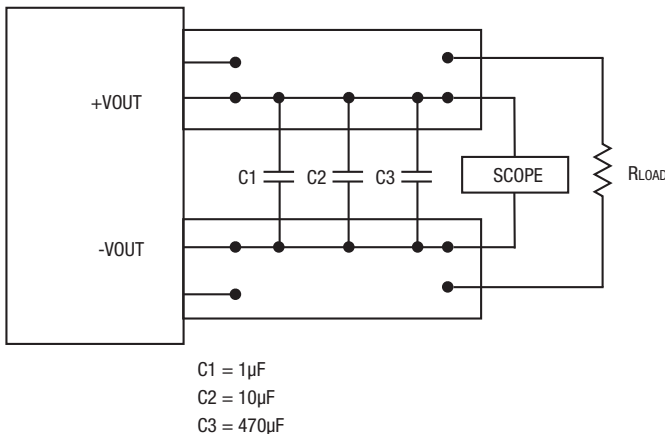

Figure 6. Measuring Output Ripple and Noise (PARD)

**Thermal Shutdown**

To prevent many over temperature problems and damage, these converters include thermal shutdown circuitry. If environmental conditions cause the temperature of the DC-DCs to rise above the Operating Temperature Range up to the shutdown temperature, an on-board electronic temperature sensor will power down the unit. When the temperature decreases below the turn-on threshold, the converter will automatically restart. There is a small amount of hysteresis to prevent rapid on/off cycling.

**CAUTION:** If you operate too close to the thermal limits, the converter may shut down suddenly without warning. Be sure to thoroughly test your application to avoid unplanned thermal shutdown.

**Temperature Derating Curves**

The graphs in this data sheet illustrate typical operation under a variety of conditions. The Derating curves show the maximum continuous ambient air temperature and decreasing maximum output current which is acceptable under increasing forced airflow measured in Linear Feet per Minute (“LFM”). Note that these are AVERAGE measurements. The converter will accept brief increases in current or reduced airflow as long as the average is not exceeded.

Note that the temperatures are of the ambient airflow, not the converter itself which is obviously running at higher temperature than the outside air. Also note that “natural convection” is defined as very low flow rates which are not using fan-forced airflow. Depending on the application, “natural convection” is usually about 30-65 LFM but is not equal to still air (0 LFM).

Murata Power Solutions makes Characterization measurements in a closed cycle wind tunnel with calibrated airflow. We use both thermocouples and an infrared camera system to observe thermal performance. As a practical matter, it is quite difficult to insert an anemometer to precisely measure airflow in most applications. Sometimes it is possible to estimate the effective airflow if you thoroughly understand the enclosure geometry, entry/exit orifice areas and the fan flowrate specifications.

**CAUTION:** If you exceed these Derating guidelines, the converter may have an unplanned Over Temperature shut down. Also, these graphs are all collected near Sea Level altitude. Be sure to reduce the derating for higher altitude.

**Output Fusing**

The converter is extensively protected against current, voltage and temperature extremes. However your output application circuit may need additional

protection. In the extremely unlikely event of output circuit failure, excessive voltage could be applied to your circuit. Consider using an appropriate fuse in series with the output.

**Output Current Limiting**

Current limiting inception is defined as the point at which full power falls below the rated tolerance. See the Performance/Functional Specifications. Note particularly that the output current may briefly rise above its rated value in normal operation as long as the average output power is not exceeded. This enhances reliability and continued operation of your application. If the output current is too high, the converter will enter the short circuit condition.

**Output Short Circuit Condition**

When a converter is in current-limit mode, the output voltage will drop as the output current demand increases. If the output voltage drops too low (approximately 97% of nominal output voltage for most models), the PWM controller will shut down. Following a time-out period, the PWM will restart, causing the output voltage to begin rising to its appropriate value. If the short-circuit condition persists, another shutdown cycle will initiate. This rapid on/off cycling is called “hiccup mode.” The hiccup cycling reduces the average output current, thereby preventing excessive internal temperatures and/or component damage. A short circuit can be tolerated indefinitely.

The “hiccup” system differs from older latching short circuit systems because you do not have to power down the converter to make it restart. The system will automatically restore operation as soon as the short circuit condition is removed.

**Remote On/Off Control**

On the input side, a remote On/Off Control can be specified with either logic type. Please refer to the Connection Diagram on page 1 for On/Off connections.

Positive-logic models are enabled when the On/Off pin is left open or is pulled high to +15V with respect to –VIN. Positive-logic devices are disabled when the On/Off is grounded or brought to within a low voltage (see Specifications) with respect to –VIN.

Negative-logic models are on (enabled) when the On/Off is grounded or brought to within a low voltage (see Specifications) with respect to –VIN. The device is off (disabled) when the On/Off is left open or is pulled high to +15VDC Max. with respect to –VIN.

Dynamic control of the On/Off function should be able to sink specified signal current when brought low and withstand specified voltage when brought high. Be aware too that there is a finite time in milliseconds (see Specifications) between the time of On/Off Control activation and stable output. This time will vary slightly with output load type and current and input conditions.

**Output Capacitive Load**

These converters do not require external capacitance added to achieve rated specifications. Users should only consider adding capacitance to reduce switching noise and/or to handle spike current load steps. Install only enough capacitance to achieve noise objectives. Excess external capacitance may cause degraded transient response and possible oscillation or instability.

### Output OVP (Output Clamped)

The RBQ-12/33-D48 module incorporates circuitry to protect the output/load (Output OVP, Over Voltage Protection) by effectively clamping the output voltage to a maximum of 13.1V under certain fault conditions. The initial output voltage is set at the factory for an accuracy of  $\pm 1.5\%$ , and is regulated over line load and temperature using a closed loop feedback system. In the event of a failure that causes the module to operate open loop (failure in the control loop), the output voltage will be determined by the input voltage/duty cycle of the voltage conversion (Pulse Width Modulation) circuit. For example, when the input voltage is at 36V, the duty cycle is D1; when the input voltage is at 75V, the maximum duty cycle is D1/2; this change in duty cycle compensates Vout for Vin changes. As Vin continues to increase above 75V the voltage at Vout is clamped because maximum duty cycle has been reached. The output voltage is always proportional to  $V_{in} \cdot \text{Duty}$  in a buck derived topology. Figure 4 is the test waveform for the RBQ-12/33-D48 module when its feedback loop is open, simulating a loop failure. Channel 1 is the input voltage and Channel 2 is the output voltage. When the input voltage climbs from 48Vdc to 100Vdc, the output voltage remains stable.

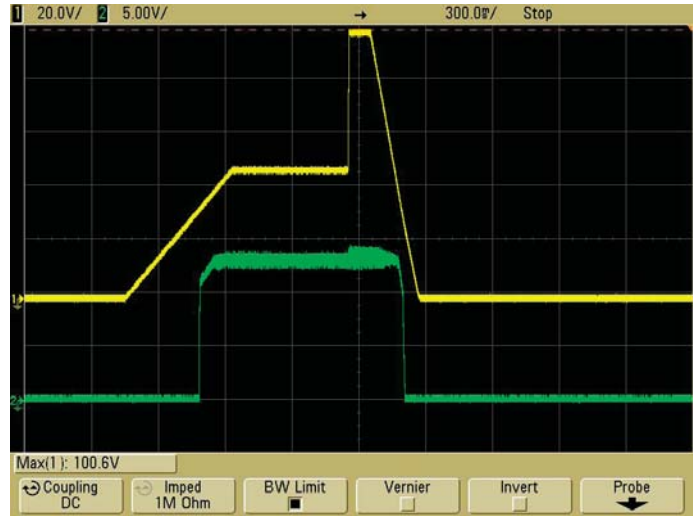

Figure 7. Test Waveform with Feedback Loop Open

**Emissions Performance, Model RBQ-12-33-D48**

Murata Power Solutions measures its products for radio frequency emissions against the EN 55022 and CISPR 22 standards. Passive resistance loads are employed and the output is set to the maximum voltage. If you set up your own emissions testing, make sure the output load is rated at continuous power while doing the tests.

The recommended external input and output capacitors (if required) are included. Please refer to the fundamental switching frequency. All of this information is listed in the Product Specifications. An external discrete filter is installed and the circuit diagram is shown below.

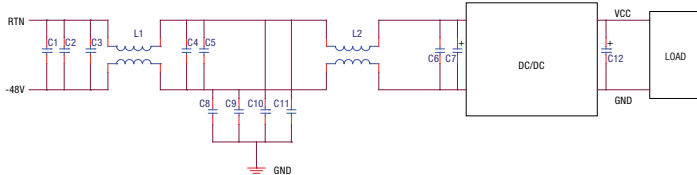

Figure 8. Conducted Emissions Test Circuit

**[1] Conducted Emissions Parts List**

Reference	Part Number	Description	Vendor
C1, C2, C3, C4, C5	GRM32ER72A105KA01L	SMD CERAMIC-100V-1000nF-X7R-1210	Murata
C6	GRM319R72A104KA01D	SMD CERAMIC100V-100nF-±10%-X7R-1206	Murata
L1, L2	PG0060T	COMMON MODE-473uH-±25%-14A	Pulse
C8, C9, C10, C11	GRM55DR72J224KW01L	SMD CERAMIC630V-0.22uF-±10%-X7R-2220	Murata
C7	UHE2A221MHD	Aluminum100V-220uF-±10%-long lead	Nichicon
C12	NA		

**[2] Conducted Emissions Test Equipment Used**

- Hewlett Packard HP8594L Spectrum Analyzer – S/N 3827A00153
- 2Line V-networks LS1-15V 50Ω/50uH Line Impedance Stabilization Network

**[3] Conducted Emissions Test Results**

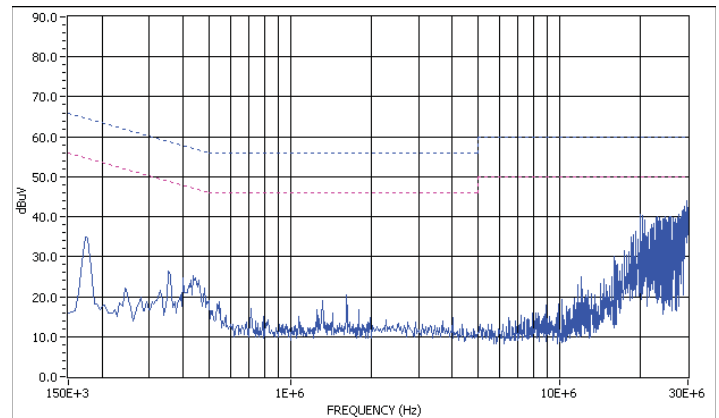

Peak Detection Value

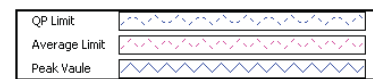

Graph 1. Conducted emissions performance, Positive Line, CISPR 22, Class B, full load

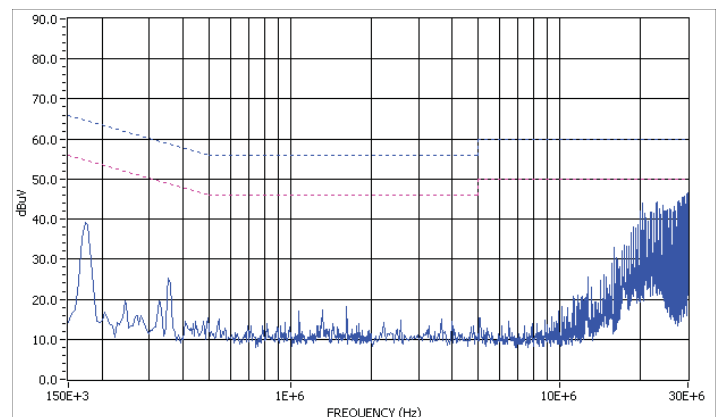

Peak Detection Value

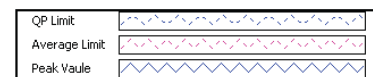

Graph 2. Conducted emissions performance, Negative Line, CISPR 22, Class B, full load

**[4] Layout Recommendations**

Most applications can use the filtering which is already installed inside the converter or with the addition of the recommended external capacitors. For greater emissions suppression, consider additional filter components and/or shielding. Emissions performance will depend on the user's PC board layout, the chassis shielding environment and choice of external components. Please refer to Application Note GEAN-02 for further discussion.

Since many factors affect both the amplitude and spectra of emissions, we recommend using an engineer who is experienced at emissions suppression.

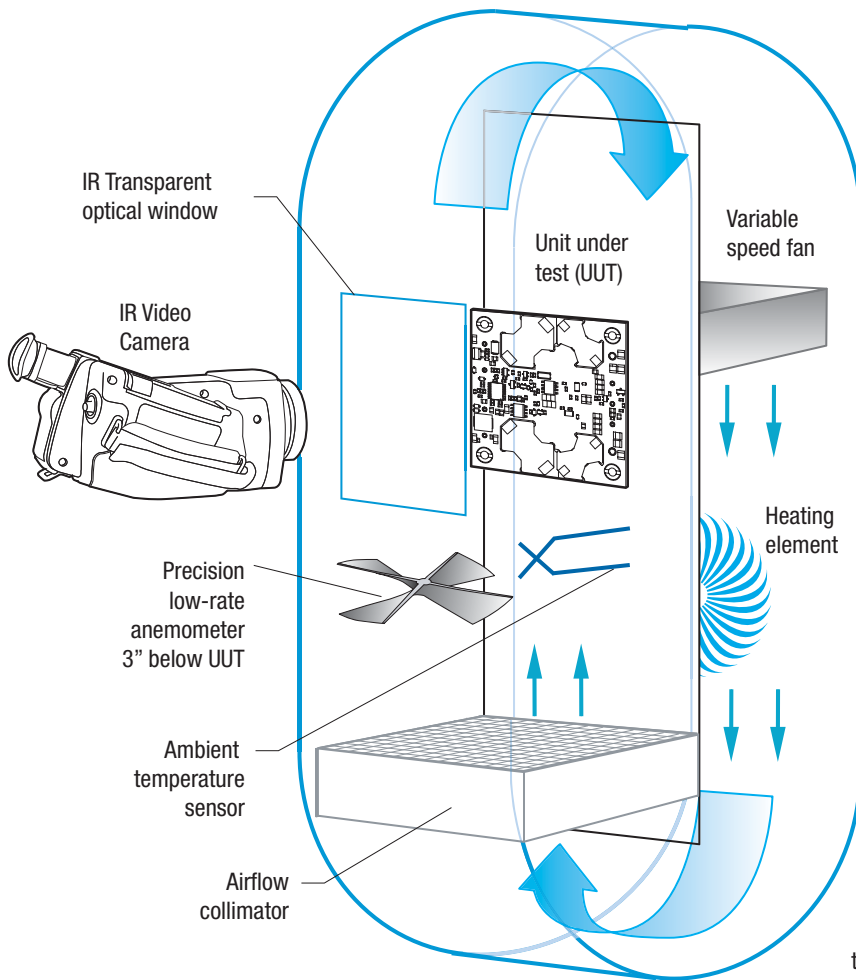

Figure 9. Vertical Wind Tunnel

**Vertical Wind Tunnel**

Murata Power Solutions employs a computer controlled custom-designed closed loop vertical wind tunnel, infrared video camera system, and test instrumentation for accurate airflow and heat dissipation analysis of power products. The system includes a precision low flow-rate anemometer, variable speed fan, power supply input and load controls, temperature gauges, and adjustable heating element.

The IR camera monitors the thermal performance of the Unit Under Test (UUT) under static steady-state conditions. A special optical port is used which is transparent to infrared wavelengths.

Both through-hole and surface mount converters are soldered down to a 10"x 10" host carrier board for realistic heat absorption and spreading. Both longitudinal and transverse airflow studies are possible by rotation of this carrier board since there are often significant differences in the heat dissipation in the two airflow directions. The combination of adjustable airflow, adjustable ambient heat, and adjustable Input/Output currents and voltages mean that a very wide range of measurement conditions can be studied.

The collimator reduces the amount of turbulence adjacent to the UUT by minimizing airflow turbulence. Such turbulence influences the effective heat transfer characteristics and gives false readings. Excess turbulence removes more heat from some surfaces and less heat from others, possibly causing uneven overheating.

Both sides of the UUT are studied since there are different thermal gradients on each side. The adjustable heating element and fan, built-in temperature gauges, and no-contact IR camera mean that power supplies are tested in real-world conditions.

**Soldering Guidelines**

Murata Power Solutions recommends the specifications below when installing these converters. These specifications vary depending on the solder type. Exceeding these specifications may cause damage to the product. Your production environment may differ; therefore please thoroughly review these guidelines with your process engineers.

Wave Solder Operations for through-hole mounted products (THMT)			
For Sn/Ag/Cu based solders:		For Sn/Pb based solders:	
Maximum Preheat Temperature	115° C.	Maximum Preheat Temperature	105° C.
Maximum Pot Temperature	270° C.	Maximum Pot Temperature	250° C.
Maximum Solder Dwell Time	7 seconds	Maximum Solder Dwell Time	6 seconds

Murata Power Solutions, Inc.  
11 Cabot Boulevard, Mansfield, MA 02048-1151 U.S.A.  
ISO 9001 and 14001 REGISTERED



**This product is subject to the following operating requirements and the Life and Safety Critical Application Sales Policy:  
Refer to: <http://www.murata-ps.com/requirements/>**

Murata Power Solutions, Inc. makes no representation that the use of its products in the circuits described herein, or the use of other technical information contained herein, will not infringe upon existing or future patent rights. The descriptions contained herein do not imply the granting of licenses to make, use, or sell equipment constructed in accordance therewith. Specifications are subject to change without notice. © 2013 Murata Power Solutions, Inc.

## X-ON Electronics

Largest Supplier of Electrical and Electronic Components

*Click to view similar products for [Isolated DC/DC Converters](#) category:*

*Click to view products by [Murata](#) manufacturer:*

Other Similar products are found below :

[ESM6D044440C05AAQ](#) [FMD15.24G](#) [PSL486-7LR](#) [PSR152.5-7IR](#) [Q48T30020-NBB0](#) [AVO240-48S12B-6L](#) [AVO250-48S28B-6L](#) [NAN-0505](#) [HW-L16D](#) [JAHW100Y1](#) [217-1617-001](#) [22827](#) [SPB05C-12](#) [SQ24S15033-PS0S](#) [18952](#) [19-130041](#) [CE-1003](#) [CE-1004](#) [GQ2541-7R](#) [PSE1000DCDC-12V](#) [RDS180245](#) [MAU228](#) [419-2065-201](#) [449-2075-101](#) [V300C24C150BG](#) [419-2062-200](#) [419-2063-401](#) [419-2067-101](#) [419-2067-501](#) [419-2068-001](#) [DCG40-5G](#) [DFC15U48D15](#) [449-2067-000](#) [XGS-0512](#) [XGS-1205](#) [XGS-1212](#) [XGS-2412](#) [XGS-2415](#) [XKS-1215](#) [033456](#) [NCT1000N040R050B](#) [SPB05B-15](#) [SPB05C-15](#) [VI-26B-CU](#) [V24C12C100BG](#) [L-DA20](#) [HP3040-9RG](#) [HP1001-9RTG](#) [XKS-2415](#) [XKS-2412](#)