

## Caution/Notice

### Caution

#### ■ Storage and Operation Conditions

#### ■ Rating

1. Operating Voltage
2. Operating Temperature and Self-generated Heat
3. Fail-safe

#### ■ Soldering and Mounting

1. Vibration and Impact
2. Soldering
3. Bonding, Resin Molding and Coating
4. Treatment after Bonding, Resin Molding and Coating

### Notice

#### ■ Rating

1. Capacitance change of capacitor

#### ■ Soldering and Mounting

1. Cleaning (ultrasonic cleaning)
2. Soldering and Mounting
  - (1) Allowable Conditions for Soldering Temperature and Time
  - (2) Insertion of the Lead Wire

## ⚠ Caution

### ■ Storage and Operation Conditions

The insulating coating of capacitors does not form a perfect seal; therefore, do not use or store capacitors in a corrosive atmosphere, especially where chloride gas, sulfide gas, acid, alkali, salt or the like are present. Also avoid exposure to moisture. Before cleaning, bonding or molding this product, verify that these processes do not affect product quality by testing the performance of a cleaned, bonded or molded product in the intended equipment. Store the capacitors where the temperature and relative humidity do not exceed 5 to 40 degrees centigrade and 20 to 70%. Use capacitors within 6 months after delivery.

### ■ Rating

#### 1. Operating Voltage

When DC-rated capacitors are to be used in AC or ripple current circuits, be sure to maintain the  $V_{p-p}$  value of the applied voltage or the  $V_{0-p}$  which contains DC bias within the rated voltage range.

When the voltage is applied to the circuit, starting or stopping may generate irregular voltage for a transit period because of resonance or switching. Be sure to use a capacitor with a rated voltage range that includes these irregular voltages.

When DC-rated capacitors are to be used in input circuits from commercial power source (AC filter), be sure to use Safety Recognized Capacitors because various regulations on withstand voltage or impulse withstand established for all equipment should be taken into consideration.

Voltage	DC Voltage	DC+AC Voltage	AC Voltage	Pulse Voltage (1)	Pulse Voltage (2)
Positional Measurement					

#### 2. Operating Temperature and Self-generated Heat

Keep the surface temperature of a capacitor below the upper limit of its rated operating temperature range. Be sure to take into account the heat generated by the capacitor itself. When the capacitor is used in a high-frequency current, pulse current or similar current, it may have self-generated heat due to dielectric loss. In the case of "High Dielectric Constant Type Capacitors," applied voltage load should be such that self-generated heat is within 20 °C under the condition where the capacitor is subjected at an atmosphere temperature of 25 °C. Please contact us if self-generated heat occurs with "Temperature Compensating Type Capacitors".

When measuring, use a thermocouple of small thermal capacity -K of  $\varnothing 0.1\text{mm}$  under conditions where the capacitor is not affected by radiant heat from other components or wind from surroundings. Excessive heat may lead to deterioration of the capacitor's characteristics and reliability. Never attempt to perform measurement with the cooling fan running. Otherwise, accurate measurement cannot be ensured.

#### 3. Fail-Safe

Be sure to provide an appropriate fail-safe function on your product to prevent a second damage that may be caused by the abnormal function or the failure of our product.

Continued on the following page.

## Caution

 Continued from the preceding page.

### ■ Soldering and Mounting

#### 1. Vibration and Impact

Do not expose a capacitor or its leads to excessive shock or vibration during use.

#### 2. Soldering

When soldering this product to a PCB/PWB, do not exceed the solder heat resistance specification of the capacitor. Subjecting this product to excessive heating could melt the internal junction solder and may result in thermal shocks that can crack the ceramic element.

#### 3. Bonding, Resin Molding and Coating

In case of bonding, molding or coating this product, verify that these processes do not affect the quality of the capacitor by testing the performance of the bonded, molded or coated product in the intended equipment.

In case the amount of application, dryness/hardening conditions of adhesives and molding resins containing organic solvents (ethyl acetate, methyl ethyl ketone, toluene, etc.) are unsuitable, the outer coating resin of a capacitor may be damaged by the organic solvents and may result, worst case, in a short circuit.

The variation in thickness of adhesive or molding resin or coating may cause an outer coating resin cracking and/or ceramic element cracking of a capacitor in a temperature cycling.

#### 4. Treatment after Bonding, Resin Molding and Coating

When the outer coating is hot (over 100 degrees centigrade) after soldering, it becomes soft and fragile, so please be careful not to give it mechanical stress.

**FAILURE TO FOLLOW THE ABOVE CAUTIONS MAY RESULT, WORST CASE, IN A SHORT CIRCUIT AND CAUSE FUMING OR PARTIAL DISPERSION WHEN THE PRODUCT IS USED.**

## Notice

### ■ Rating

#### 1. Capacitance change of capacitor

In case of F/X7R/X7S/X7T/X8L/Y5V/Z5U char.

Capacitors have an aging characteristic, whereby the capacitor continually decreases its capacitance slightly if the capacitor is left on for a long time. Moreover, capacitance might change greatly depending on the surrounding temperature or an applied voltage.

### ■ Soldering and Mounting

#### 1. Cleaning (ultrasonic cleaning)

To perform ultrasonic cleaning, observe the following conditions.

Rinse bath capacity: Output of 20 watts per liter or less.

Rinsing time: 5 min. maximum.

Do not vibrate the PCB/PWB directly.

Excessive ultrasonic cleaning may lead to fatigue destruction of the lead wires.

#### 2. Soldering and Mounting



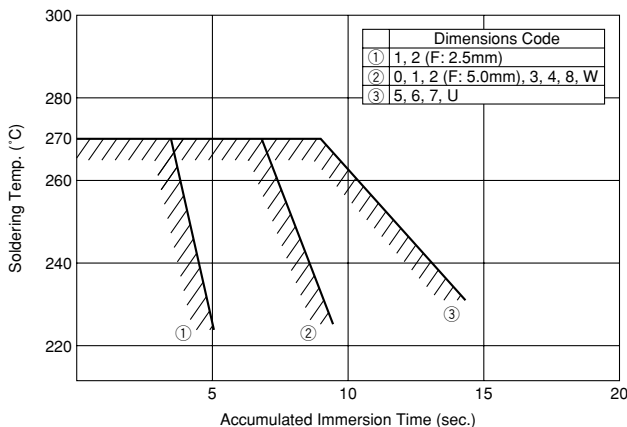





##### (1) Allowable Conditions for Soldering Temperature and Time



Perform soldering within tolerance range (shaded portion).

##### (2) Insertion of the Lead Wire

- When soldering, insert the lead wire into the PCB without mechanically stressing the lead wire.
- Insert the lead wire into the PCB with a distance appropriate to the lead space.

Dimensions Code	Temp. Char.	C0G	X7R	Y5V
2	Individual Specification Code A□□ B□□ Z□□	 102J    5A Marked on both sides	 222K	 224Z
	Individual Specification Code Except A□□ B□□ Z□□	 682 J5A	 224 K5C	 474 Z5F
3, 8		—	 684 K5C	—
5, 6, 7		—	 225 K5C	—
Temperature Characteristics	Marked with code (C0G char.: A, X7R char.: C, Y5V char.: F) A part is omitted (Please refer to the marking example.)			
Nominal Capacitance	Under 100pF: Actual value    100pF and over: marked with 3 figures			
Capacitance Tolerance	Marked with code			
Rated Voltage	Marked with code (DC25V: 2, DC50V: 5, DC100V: 1) A part is omitted (Please refer to the marking example.)			
Manufacturer's Identification	Marked with  A part is omitted (Please refer to the marking example.)			

No.	Item	Temperature Compensating Type	High Dielectric Constant Type	Test Method												
1	Operating Temperature Range	-55 to +125°C	Char. X7R : -55 to +125°C Char. Y5V : -30 to +85°C	-												
2	Rated Voltage	See previous pages		The rated voltage is defined as the maximum voltage that may be applied continuously to the capacitor. When AC voltage is superimposed on DC voltage or $V_{0-P}$ , whichever is larger, should be maintained within the rated voltage range.												
3	Appearance	No defects or abnormalities		Visual inspection												
4	Dimension and Marking	See previous pages		Visual inspection, Vernier Caliper												
5	Dielectric Strength	Between Terminals	No defects or abnormalities	The capacitors should not be damaged when DC voltages of 300%* of the rated voltage are applied between the terminals for 1 to 5 sec. (Charge/Discharge current $\leq$ 50mA) *250% for char. X7R, Y5V  The capacitor is placed in a container with metal balls of 1mm diameter so that each terminal, short-circuited, is kept approximately 2mm from the balls as shown in the figure, and 250% of the rated DC voltage is impressed for 1 to 5 sec. between capacitor terminals and metal balls. (Charge/Discharge current $\leq$ 50mA)												
		Body Insulation	No defects or abnormalities													
6	Insulation Resistance	Between Terminals	$C \leq 0.047\mu\text{F}$ : 10,000M $\Omega$ min. $C > 0.047\mu\text{F}$ : 500M $\Omega \cdot \mu\text{F}$ min. C : Nominal capacitance	The insulation resistance should be measured with DC voltage not exceeding the rated voltage at normal temperature and humidity and within 2 min. of charging. (Charge/Discharge current $\leq$ 50mA)												
7	Capacitance	Within the specified tolerance		The capacitance, Q/D.F. should be measured at the frequency and voltage shown in the table.												
8	Q/Dissipation Factor (D.F.)	30pF min. : $Q \geq 1,000$ 30pF max. : $Q \geq 400+20C$ C : Nominal capacitance (pF)	Char. X7R : 0.025 max. Char. Y5V : 0.05 max.	<table border="1"> <thead> <tr> <th>Capacitance</th> <th>1000pF and below</th> <th>more than 1000pF</th> </tr> </thead> <tbody> <tr> <td>Item</td> <td></td> <td></td> </tr> <tr> <td>Frequency</td> <td>1<math>\pm</math>0.1MHz</td> <td>1<math>\pm</math>0.1kHz</td> </tr> <tr> <td>Voltage</td> <td>AC0.5 to 5V (r.m.s.)</td> <td>AC1<math>\pm</math>0.5V (r.m.s.)</td> </tr> </tbody> </table>	Capacitance	1000pF and below	more than 1000pF	Item			Frequency	1 $\pm$ 0.1MHz	1 $\pm$ 0.1kHz	Voltage	AC0.5 to 5V (r.m.s.)	AC1 $\pm$ 0.5V (r.m.s.)
Capacitance	1000pF and below	more than 1000pF														
Item																
Frequency	1 $\pm$ 0.1MHz	1 $\pm$ 0.1kHz														
Voltage	AC0.5 to 5V (r.m.s.)	AC1 $\pm$ 0.5V (r.m.s.)														
9	Capacitance Temperature Characteristics	Capacitance Change	Within the specified tolerance (Table A on last column)	Within the specified tolerance (Table B on last column)												
		Temperature Coefficient	Within the specified tolerance (Table A on last column)													
		Capacitance Drift	Within $\pm 0.2\%$ or $\pm 0.05\text{pF}$ , whichever is larger													
				<p>The capacitance change should be measured at the minimum value at each specified temperature stage.</p> <p>(1) Temperature Compensating Type The temperature coefficient is determined using the capacitance measured in step 3 as a reference. By cycling the temperature sequentially from step 1 through 5 (-55 to +125°C) the capacitance should be measured at each stage. The capacitance change should be within the specified tolerance for the temperature coefficient and capacitance change as shown in Table A. The capacitance drift is calculated by dividing the differences between the maximum and minimum measured values in step 1, 3 and 5 by the capacitance value in step 3.</p> <table border="1"> <thead> <tr> <th>Step</th> <th>Temperature (°C)</th> </tr> </thead> <tbody> <tr> <td>1</td> <td>25<math>\pm</math>2</td> </tr> <tr> <td>2</td> <td>-55<math>\pm</math>3</td> </tr> <tr> <td>3</td> <td>25<math>\pm</math>2</td> </tr> <tr> <td>4</td> <td>125<math>\pm</math>3</td> </tr> <tr> <td>5</td> <td>25<math>\pm</math>2</td> </tr> </tbody> </table> <p>(2) High Dielectric Constant Type The ranges of capacitance change compared with the 25°C value over the temperature ranges as shown in Table B should be within the specified ranges.</p>	Step	Temperature (°C)	1	25 $\pm$ 2	2	-55 $\pm$ 3	3	25 $\pm$ 2	4	125 $\pm$ 3	5	25 $\pm$ 2
Step	Temperature (°C)															
1	25 $\pm$ 2															
2	-55 $\pm$ 3															
3	25 $\pm$ 2															
4	125 $\pm$ 3															
5	25 $\pm$ 2															

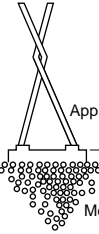

Continued on the following page

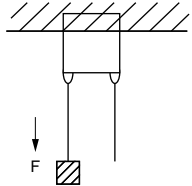
No.	Item	Temperature Compensating Type	High Dielectric Constant Type	Test Method	
10	Terminal Strength	Tensile Strength	Termination not to be broken or loosened		<p>As in the figure, fix the capacitor body, apply the force gradually to each lead in the radial direction of the capacitor until reaching 10N and then keep the force applied for 10±1 sec.</p> 
		Bending Strength	Termination not to be broken or loosened		Each lead wire should be subjected to a force of 10N and then bent 90° at the point of egress in one direction. Each wire is then returned to the original position and bent 90° in the opposite direction at a rate of one bend per 2 to 3 sec.
11	Vibration Resistance	Appearance	No defects or abnormalities		The capacitor is soldered securely to a supporting terminal and a 10 to 55Hz vibration of 1.5mm peak amplitude is applied for 6 hrs. total, 2 hrs. in mutually perpendicular direction. Allow 1 min. to settle the frequency from 10Hz to 55Hz and the conversion.
		Capacitance	Within the specified tolerance		
		Q/D.F.	30pF min. : Q ≥ 1,000 30pF max. : Q ≥ 400+20C C : Nominal capacitance (pF)	Char. X7R : 0.025 max. Char. Y5V : 0.05 max.	
12	Solderability of Leads	Lead wire should be soldered with uniform coating on the axial direction over 3/4 of the circumferential direction.		The terminal of a capacitor is dipped into a 25% e (JIS-K-8101) solution of rosin (JIS-K-5902) and then into molten solder for 2±0.5 sec. In both cases, the depth of dipping is up to about 1.5mm to 2mm from the terminal body. Temp. of solder: 245±5°C Lead Free Solder (Sn-3.0Ag-0.5Cu) or 235±5°C H60A or H63A Eutectic Solder	
13	Resistance to Soldering Heat	Appearance	No defects or abnormalities		<p>The lead wire is immersed in the melted solder 1 to 2mm from the main body at 350±10°C for 3.5±0.5 sec. The specified items are measured after 24±2 hrs. (temperature compensating type) or 48±4 hrs. (high dielectric type).</p> <p>• Initial measurement for high dielectric constant type</p> <p>The capacitors are heat treated for 1 hr. at 150±5°C, allowed to set at room temperature for 48±4 hrs. and given an initial measurement.</p>
		Capacitance Change	Within ±2.5% or ±0.25pF (whichever is larger)	Char. X7R : Within ±7.5% Char. Y5V : Within ±20%	
		Dielectric Strength (Between Terminals)	No defects		
14	Temperature and Immersion Cycle	Appearance	No defects or abnormalities		<p>First, repeat the following temperature/time cycle times:</p> <ul style="list-style-type: none"> <li>» lowest operating temperature ±3°C/30±3 min.</li> <li>» ordinary temperature/3 min. max.</li> <li>» highest operating temperature ±3°C/30±3 min.</li> <li>» ordinary temperature/3 min. max.</li> </ul> <p>Next, repeat twice the successive cycles of immersion in a fresh water bath at 65±5°C for 15 min. and immersion in a saturated aqueous solution of salt at 0±3°C for 15 min. The capacitor is then promptly washed in running water, dried with a drying cloth, and allowed to sit at room temperature for 24±2 hrs. (temperature compensating type) or 48±4 hrs. (high dielectric type).</p> <p>• Initial measurement for high dielectric constant type</p> <p>The capacitors are heat treated for 1 hr. at 150±5°C, allowed to sit at room temperature for 24±2 hrs., and given an initial measurement.</p>
		Capacitance Change	Within ±5% or ±0.5pF (whichever is larger)	Char. X7R : Within ±12.5% Char. Y5V : Within ±30%	
		Q/D.F.	30pF min. : Q ≥ 350 10pF to 30pF : Q ≥ 275+5C/2 10pF max. : Q ≥ 200+10C C : Nominal capacitance (pF)	Char. X7R : 0.05 max. Char. Y5V : 0.075 max.	
		Insulation Resistance	1,000MΩ or 50MΩ • μF min. (whichever is smaller)		
		Dielectric Strength (Between Terminals)	No defects or abnormalities		

Continued on the following page

No.	Item	Temperature Compensating Type	High Dielectric Constant Type	Test Method		
15	Humidity (Steady State)	Appearance	No defects or abnormalities		Set the capacitor for 500 $\pm 24_0$ hrs. at 40 $\pm 2$ °C in 90 to 95% humidity. Remove and set for 24 $\pm 2$ hrs. (temperature compensating type) and 48 $\pm 4$ hrs. (dielectric constant type) at room temperature, then measure.	
		Capacitance Change	Within $\pm 5\%$ or $\pm 0.5\text{pF}$ (whichever is larger)	Char. X7R : Within $\pm 12.5\%$ Char. Y5V : Within $\pm 30\%$		
		Q/D.F.	30pF min. : $Q \geq 350$ 10pF to 30pF : $Q \geq 275+5C/2$ 10pF max. : $Q \geq 200+10C$ C : Nominal capacitance (pF)	Char. X7R : 0.05 max. Char. Y5V : 0.075 max.		
		Insulation Resistance	1,000M $\Omega$ or 50M $\Omega \cdot \mu\text{F}$ min. (whichever is smaller)			
16	Humidity Load	Appearance	No defects or abnormalities		Apply the rated voltage for 500 $\pm 24_0$ hrs. at 40 $\pm 2$ °C in 90 to 95% humidity. Remove and set for 24 $\pm 2$ hrs. (temperature compensating type) and 48 $\pm 4$ hrs. (dielectric constant type) at room temperature, then measure. (Charge/Discharge current $\leq 50\text{mA}$ )	
		Capacitance Change	Within $\pm 7.5\%$ or $\pm 0.75\text{pF}$ (whichever is larger)	Char. X7R : Within $\pm 12.5\%$ Char. Y5V : Within $\pm 30\%$		
		Q/D.F.	30pF min. : $Q \geq 200$ 30pF max. : $Q \geq 100+10C/3$ C : Nominal capacitance (pF)	Char. X7R : 0.05 max. Char. Y5V : 0.075 max.		
		Insulation Resistance	500M $\Omega$ or 25M $\Omega \cdot \mu\text{F}$ min. (whichever is smaller)			
17	High Temperature Load	Appearance	No defects or abnormalities		Apply 200% of the rated voltage for 1000 $\pm 48_0$ hrs. at the maximum operating temperature. Remove and set for 24 $\pm 2$ hrs. (temperature compensating type) and 48 $\pm 4$ hrs. (high dielectric constant type) at room temperature, then measure. (Charge/Discharge current $\leq 50\text{mA}$ )  • Initial measurement for high dielectric constant type A voltage treatment should be given to the capacitor which a DC voltage of 200% of the rated voltage is applied for 1 hr. at the maximum operating temperature $\pm 3$ °C. Then set for 48 $\pm 4$ hrs. at room temperature, then conduct initial measurement.	
		Capacitance Change	Within $\pm 3\%$ or $\pm 0.3\text{pF}$ (whichever is larger)	Char. X7R : Within $\pm 12.5\%$ Char. Y5V : Within $\pm 30\%$		
		Q/D.F.	30pF min. : $Q \geq 350$ 10pF to 30pF : $Q \geq 275+5C/2$ 10pF max. : $Q \geq 200+10C$ C : Nominal capacitance (pF)	Char. X7R : 0.04 max. Char. Y5V : 0.075 max.		
		Insulation Resistance	1,000M $\Omega$ or 50M $\Omega \cdot \mu\text{F}$ min. (whichever is smaller)			
18	Solvent Resistance	Appearance	No defects or abnormalities		The capacitor should be fully immersed, unagitated in reagent at 20 to 25°C for 30 $\pm 5$ sec. and then removed gently. Marking on the surface of the capacitor should immediately be visually examined. Reagent: • Isopropyl alcohol	
		Marking	Legible			

Table A

Char.	Nominal Values (ppm/°C) *1	Capacitance Change from 25°C (%)					
		-55°C		-30°C		-10°C	
		Max.	Min.	Max.	Min.	Max.	Min.
<b>C0G</b>	0 $\pm 30$	0.58	-0.24	0.40	-0.17	0.25	-0.11

\*1: Nominal values denote the temperature coefficient within a range of 25 to 125°C

Table B

Char.	Temp. Range	Reference Temp.	Cap. Change
<b>X7R</b>	-55 to +125°C	25°C	Within $\pm 15\%$
<b>Y5V</b>	-30 to + 85°C		Within $\pm 22\%$



## ■ Packaging

Two types of packaging for monolithic ceramic capacitors are available.

### 1. Bulk Packaging

Minimum Quantity

Dimensions Code	Dimensions (L×W)	Minimum Quantity (pcs./Bag)*
0	3.6×3.5mm or 4.0×3.5mm or 5.0×3.5mm (Depends on Part Number)	500
1	4.0×3.5mm or 4.5×3.5mm or 5.0×3.5mm (Depends on Part Number)	
2	5.0×3.5mm or 5.5×4.0mm or 5.7×4.5mm (Depends on Part Number)	
3	5.0×4.5mm or 5.5×5.0mm or 6.0×5.5mm (Depends on Part Number)	
4	7.5×5.5mm	
5	7.5×7.5mm or 7.5×8.0mm (Depends on Part Number)	
6	10.0×10.0mm	
8	7.5×5.5mm	
7	12.5×12.5mm	100
U	7.7×12.5mm or 7.7×13.0mm (Depends on Part Number)	200
W	5.5×7.5mm or 6.0×8.0mm (Depends on Part Number)	500

Please order with an integral multiple of the minimum quantity above.

\* Minimum Quantity may change depends on part number.

Please check our website 'Product details'.

### 2. Tape Carrier Packaging

(1) Dimensions of Ammo Pack

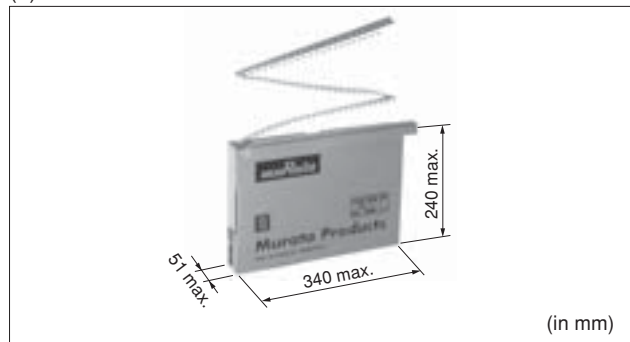

(2) Minimum Quantity

Dimensions Code	Dimensions (L×W)	Minimum Quantity (pcs./Ammo Pack)*
0	3.6×3.5mm or 4.0×3.5mm or 5.0×3.5mm (Depends on Part Number)	2000
1	4.0×3.5mm or 4.5×3.5mm or 5.0×3.5mm (Depends on Part Number)	
2	5.0×3.5mm or 5.5×4.0mm or 5.7×4.5mm (Depends on Part Number)	
3	5.0×4.5mm or 5.5×5.0mm or 6.0×5.5mm (Depends on Part Number)	
4	7.5×5.5mm	2000
5	7.5×7.5mm or 7.5×8.0mm (Depends on Part Number)	
6	10.0×10.0mm	1500
8	7.5×5.5mm	
U	7.7×12.5mm or 7.7×13.0mm (Depends on Part Number)	1000
W	5.5×7.5mm or 6.0×8.0mm (Depends on Part Number)	1500

Please order with an integral multiple of the minimum quantity above.

\* Minimum Quantity may change depends on part number.

Please check our website 'Product details'.

"Minimum Quantity" means the numbers of units of each delivery or order. The quantity should be an integral multiple of the "minimum quantity".  
(Please note that the actual delivery quantity in a package may change sometimes.)

Continued on the following page.

Continued from the preceding page.

**Taping Dimensions**

**Inside Crimp Taping**

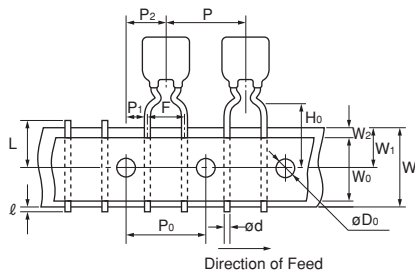

Dimensions and Lead Style Code
0M1
1M1
2M1
2M2
3M1
3M2
4M1
4M2
8M1
8M2
WM1

**Straight Taping**

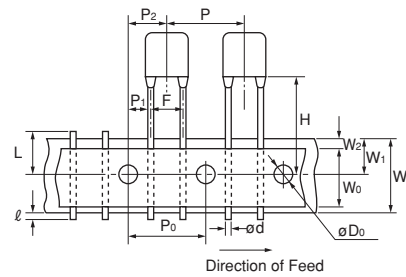

Dimensions and Lead Style Code
1DB
2DB
3DB
5E1
5E2
6E1
6E2
UE1

**Outside Crimp Taping**

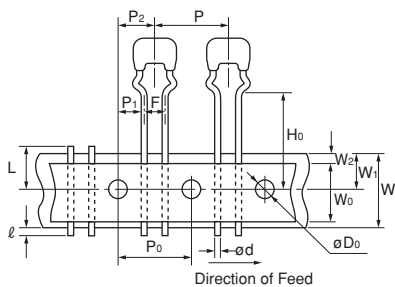

Dimensions and Lead Style Code
0S1
1S1
2S1
2S2
3S1
3S2

Item	Code	Dimensions (mm)
Pitch of Component	P	12.7±1.0
Pitch of Sprocket Hole	P <sub>0</sub>	12.7±0.2
Lead Spacing	F	2.5 <sup>+0.4</sup> <sub>-0.2</sub> (DB) (S1) (S2)
		5.0 <sup>+0.6</sup> <sub>-0.2</sub>
Length from Hole Center to Component Center	P <sub>2</sub>	6.35±1.3
Length from Hole Center to Lead	P <sub>1</sub>	3.85±0.7
		5.1±0.7 (DB) (S1) (S2)
		254±1.5 Total length of components pitch X 20
Body Dimension	Depends on Part Number	
Deviation Along Tape, Left or Right Defect	ΔS	±2.0
Carrier Tape Width	W	18.0±0.5
Position of Sprocket Hole	W <sub>1</sub>	9.0 <sup>+0</sup> <sub>-0.5</sub>
Lead Distance between Reference and Bottom Plane	H <sub>0</sub>	16.0±0.5 (M1) (S1)
		20.0±0.5 (M2) (S2)
For Straight Lead Type	H	20±0.5 (E2), 17.5±0.5 (E1), 16±0.5 (DB)
Diameter of Sprocket Hole	D <sub>0</sub>	4.0±0.1
Lead Diameter	d	0.5±0.05
Total Tape Thickness	t <sub>1</sub>	0.6±0.3
Total Thickness of Tape and Lead Wire	t <sub>2</sub>	1.5 max.
Body Thickness	T	Depends on Part Number
Deviation Across Tape	Δh <sub>1</sub> Δh <sub>2</sub>	2.0 max. Dimensions Code: W, U
		1.5 max. RHD Series
		1.0 max. except as above
Portion to Cut in Case of Defect	L	11.0 <sup>+0</sup> <sub>-1.0</sub>
Protrusion Length	ℓ	0.5 max.
Hold Down Tape Width	W <sub>0</sub>	9.5 min.
Hold Down Tape Position	W <sub>2</sub>	1.5±1.5
Coating Extension	Depends on Dimensions	

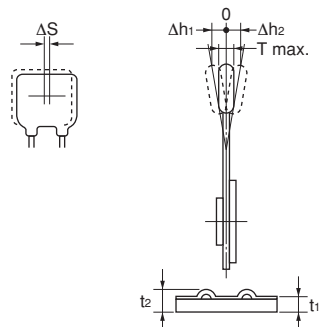

## X-ON Electronics

Largest Supplier of Electrical and Electronic Components

*Click to view similar products for [Multilayer Ceramic Capacitors MLCC - Leaded](#) category:*

*Click to view products by [Murata](#) manufacturer:*

Other Similar products are found below :

[010-007220-002REV A](#) [M39014/011207](#) [M39014/011225](#) [M39014/011267](#) [M39014/011277](#) [M39014/01-1281V](#) [M39014/01-1284V](#)  
[M39014/01-1293](#) [M39014/011299](#) [M39014/011327](#) [M39014/011332](#) [M39014/01-1333V](#) [M39014/011335](#) [M39014/01-1339V](#)  
[M39014/011443](#) [M39014/01-1443V](#) [M39014/01-1467](#) [M39014/011489](#) [M39014/01-1489V](#) [M39014/011514](#) [M39014/011572](#) [M39014/01-](#)  
[1581V](#) [M39014/01-1593](#) [M39014/021218](#) [M39014/021223](#) [M39014/021225](#) [M39014/02-1240V](#) [M39014/02-1241V](#) [M39014/02-1262V](#)  
[M39014/02-1300V](#) [M39014/021303](#) [M39014/02-1315V](#) [M39014/02-1338](#) [M39014/02-1354V](#) [M39014/021411](#) [M39014/02-1418V](#)  
[M39014/05-2103](#) [M39014/05-2127](#) [M39014/220697](#) [M39014/221162](#) [M39014/230073](#) [M39014/230319](#) [M39014/230355](#) [Q52-DK](#)  
[NCD332M1KVZ5UF](#) [C410C201J1G5TATR](#) [C410C221K1G5TATR](#) [C420C102J1G5TATR](#) [C430C104M1U5TATR](#) [SL217C103KAB](#)