

## SVM4A103A0L17R00



### Rotary Position Sensor Smaller Type

#### Features

- High Durability: 1M cycles
- Pb Free Soldering: 260°C
- Operating Temperature: -40°C to +85°C
- Terminal Shape: SMD Type
- Rotational Rotor: Through Hole Type
- Small Type: 4.0 x 4.5 x 2.0mm
- RoHS Compliant

#### Applications

- Switch for various goods
- Digital still camera
- Head set
- Toy robot
- Motor drive unit
- Game controller

#### Overview

Small type for Consumer market

4mm-size position sensor can be operated at temperature from -40 to +85 deg, and has endurance up to 1 M cycles.

---

#### Attention:

This datasheet is downloaded from the website of Murata Manufacturing Co., Ltd.  
Therefore, it's specifications are subject to change or our products in it may be discontinued without advance notice.  
Please check with our sales representatives or product engineers before ordering.

## TABLE OF CONTENT

<b>1. Introduction</b> .....	<b>1</b>
<b>2. Specification</b> .....	<b>3</b>
2.1 Operating Conditions	
2.2 Performance of Electrical Specifications	
2.3 Environmental Specifications	
2.4 Other Characteristics	
<b>3. Outline Dimensions and Land pattern</b> .....	<b>5</b>
<b>4. Test Method</b> .....	<b>6</b>
4.1 Linearity	
4.2 Temperature Coefficient of Resistance (TCR)	
4.3 High Temperature Exposure	
4.4 Low Temperature Exposure	
4.5 Humidity	
4.6 Humidity Load Life	
4.7 Temperature Cycle	
4.8 High Temperature Load Life	
4.9 Rotational Life (reciprocal motion)	
4.10 Vibration	
4.11 Shock	
4.12 Resistance to soldering heat	
4.13 Vertical Strength of the Rotor	
4.14 Edgewise Strength of the Rotor	
4.15 Solderability	
<b>5. Packing Information</b> .....	<b>9</b>
5.1 Part Number and Packing	
5.2 Taping Specification	
<b>6. ⚠CAUTION</b> .....	<b>10</b>
6.1 Limitation of Applications	
6.2 Fail-Safe	
6.3 Notice in Design and Usage	
6.4 Notice in Storage	
6.5 Notice in Circuit Design and Other	
6.6 Other	

### Attention:

This datasheet is downloaded from the website of Murata Manufacturing Co., Ltd.  
Therefore, it's specifications are subject to change or our products in it may be discontinued without advance notice.  
Please check with our sales representatives or product engineers before ordering.

## 2. Specification

### 2.1 Operating Conditions

Table 1. Operating Conditions

Parameter	Spec	Test Method
Rated voltage	DC5±0.5V	-
Operating Temperature Range	-40 ~ +85 degC	-

### 2.2 Performance of Electrical Specifications

Table 2. Performance of Electrical Specifications

Parameter	Spec	Test Method
Standard total resistance range	10K ohm	-
Standard total resistance range	±30% of standard total resistance value	-
Linearity	±2%	4.1
Dielectric strength	250Vac, 1 min, Leakage current less than 50μA	-
Insulation resistance	100Mohm min. (250Vdc)	-
Temperature coefficient of resistance (TCR)	±500ppm/°C	4.2
Electrical rotational angle	(Ref. : 260°)	-
Electrical open area	30±5° max.	-
Rotational torque	6mN·m max.	-

#### Attention:

This datasheet is downloaded from the website of Murata Manufacturing Co., Ltd. Therefore, it's specifications are subject to change or our products in it may be discontinued without advance notice. Please check with our sales representatives or product engineers before ordering.

## 2.3 Environmental Specifications

Table 3. Environmental Specifications

ITEM	SPECIFICATION		TEST METHOD
	Total Resistance Change	Linearity	
High temperature exposure	+5/-30%	±3%	4.3
Low temperature exposure	±20%	±3%	4.4
Humidity	±20%	±3%	4.5
Humidity load life	±20%	±3%	4.6
Temperature cycle	±20%	±3%	4.7
High temperature load Life	+5/-30%	±3%	4.8
Rotational life (reciprocal motion)	±20%	±3%	4.9
Vibration	±10%	±3%	4.10
Shock	±10%	±3%	4.11
Resistance to soldering heat	±20%	±3%	4.12
Vertical strength of the rotor	No mechanical deformation and damage		4.13
Edgewise strength of the rotor	No mechanical deformation and damage		4.14

## 2.4 Other characteristics

Table 4. Solderability

ITEM	SPECIFICATION	TEST METHOD
Solderability	More than 90 percent covered with solder coating	4.15

### Attention:

This datasheet is downloaded from the website of Murata Manufacturing Co., Ltd. Therefore, it's specifications are subject to change or our products in it may be discontinued without advance notice. Please check with our sales representatives or product engineers before ordering.

### 3. Outline Dimensions and Land pattern

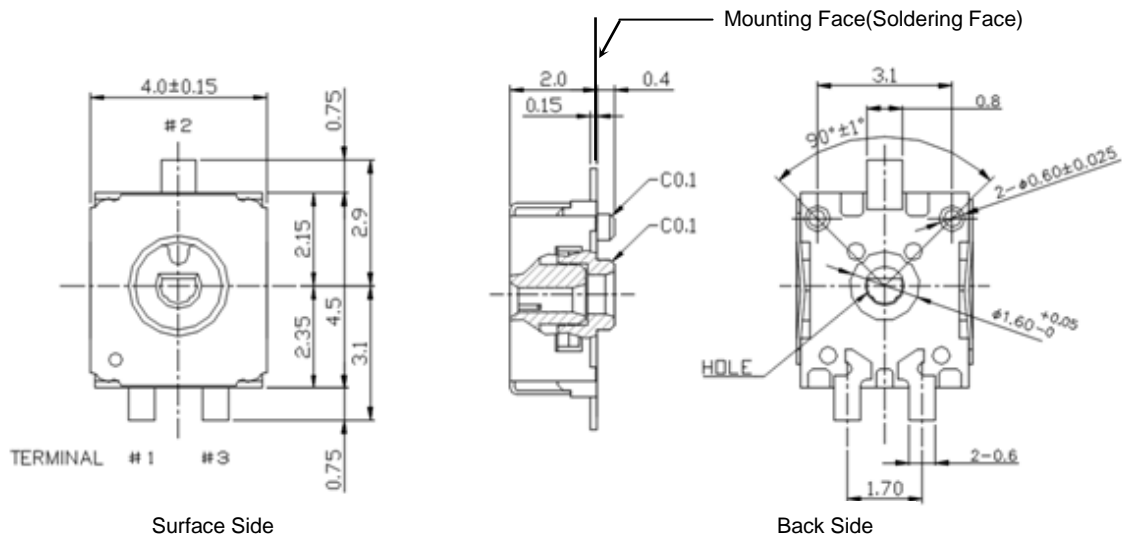

Fig.1 Dimensions

(Unit : mm)  
(Tolerance :  $\pm 0.1$ mm)

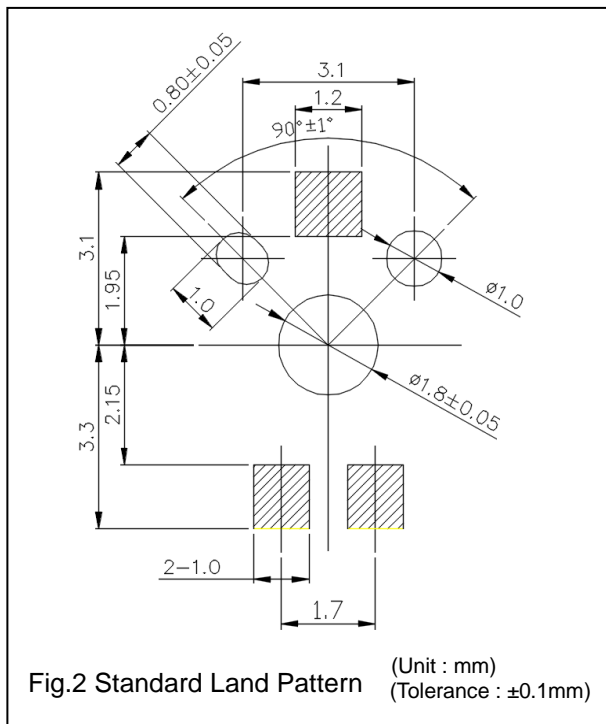

Fig.2 Standard Land Pattern (Unit : mm)  
(Tolerance :  $\pm 0.1$ mm)

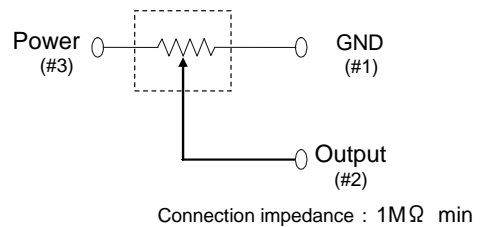

Fig.3 Circuit Diagram

The hole size of the three above-mentioned places is a value on condition of manual soldering. When using a mounting machine, please expand the size of each hole to the value which applied the mounting accuracy of the mounting machine.

**Attention:**

This datasheet is downloaded from the website of Murata Manufacturing Co., Ltd. Therefore, it's specifications are subject to change or our products in it may be discontinued without advance notice. Please check with our sales representatives or product engineers before ordering.

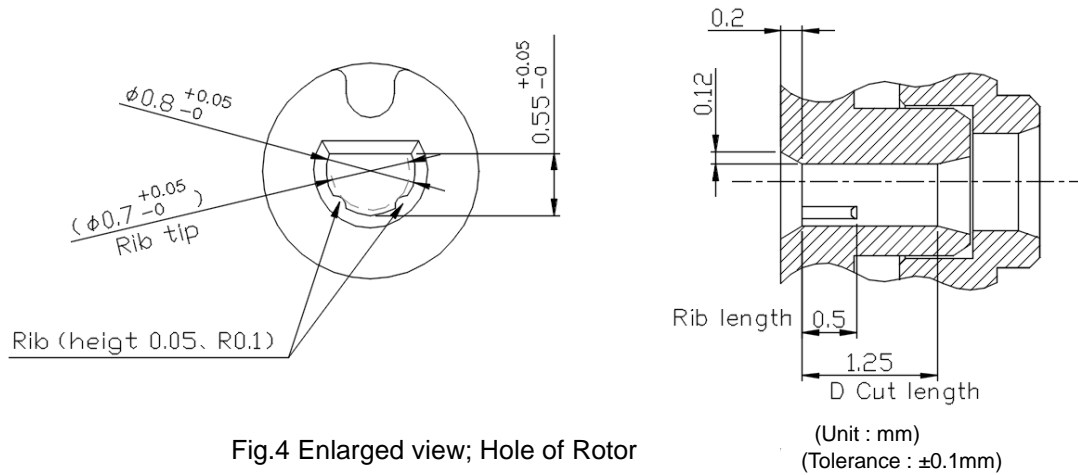

Fig.4 Enlarged view; Hole of Rotor

## 4. Test Method

The tests and measurements shall be conducted under the condition of 15~35°C of temperature 25~75% of relative humidity and 86~106 k pa of atmospheric pressure unless otherwise specified. In case when entertained a doubt in judgment obtained from results measured in accordance with the above mentioned conditions, the tests and measurements shall be conducted under the condition of 25±2°C of temperature and, 50±2% of relative humidity and 86~106 k pa of atmospheric pressure. When the potentiometer is tested after soldering on PCB, it shall be tested after being kept in a room (15~35°C, 25~75%RH) over 24 hours except "Resistance to soldering heat".

### 4.1 Linearity

Linearity should be specified a deviation with be below ideal straight line, between ±120 degrees from the index point which is 50% of output voltage.

The ideal straight line has 100%/260 degrees as taper and pass the above index point.

Measurement is performed using the following measurement circuit, and the rotor should be rotated to clockwise direction.

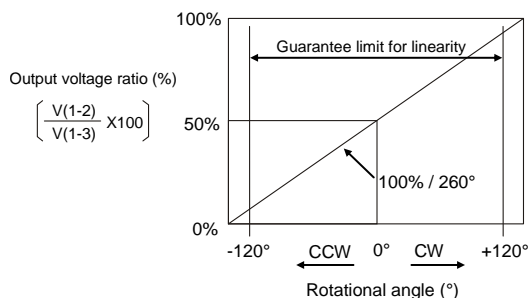

Fig.5 Linearity

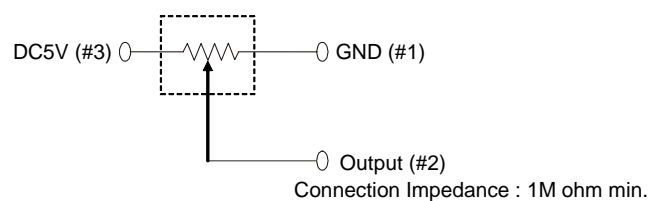

Fig.6 Circuit Diagram

### Attention:

This datasheet is downloaded from the website of Murata Manufacturing Co., Ltd. Therefore, it's specifications are subject to change or our products in it may be discontinued without advance notice. Please check with our sales representatives or product engineers before ordering.

#### 4.2 Temperature coefficient of resistance (TCR)

The rotary position sensor should be subjected to each of the following temperatures for 30~45 minutes.

Table 5. Temperature coefficient of resistance

Sequence	*1	2	*3	4
Temp. (°C)	+25	-40	+25	+85

Note\* : Reference temperature

Temperature coefficient of resistance should be applied to the following formula

$$TCR = \frac{R_2 - R_1}{R_1(T_2 - T_1)} \times 10^6 \text{ (ppm / } ^\circ\text{C)}$$

T<sub>1</sub> : Reference temperature in degrees Celsius

T<sub>2</sub> : Test temperature in degrees Celsius

R<sub>1</sub> : Resistance at reference temperature in ohm

R<sub>2</sub> : Resistance at test temperature in ohm

#### 4.3 High temperature exposure

The rotary position sensor should be stored in a chamber at a temperature of 85±2°C without loading for 1000±8 hours. After removing from the chamber, the rotary position sensor should be kept in the dry box for 1-2 hours.

#### 4.4 Low temperature exposure

The rotary position sensor should be stored in a chamber at a temperature of -40±3°C without loading for 1000±8 hours. After removing from the chamber, the rotary position sensor should be kept in the dry box for 1-2 hours

#### 4.5 Humidity

The rotary position sensor should be stored in a chamber at temperature of 60±2°C and relative humidity of 90-95% for 1000±8 hrs. After removing from the chamber, the rotary position sensor should be kept in the dry box for 5 hours ±10min.

#### 4.6 Humidity load life

Full rated continuous working voltage not exceeding 5Vdc should be applied intermittently between terminal #1 and terminal #3 of the rotary position sensor, 1.5 hours on and 0.5 hours off, for 1000±8 hours in total in a chamber at a temperature of 60±2°C and the relative humidity of 90-95%. After removing from the chamber, the rotary position sensor should be kept in the dry box for 5 hours ±10 min.

#### 4.7 Temperature cycle

The rotary position sensor should be subjected to Table 6 temperature for 1000 cycles. Then, the rotary position sensor should be kept in the dry box for 1~2 hours.

Table 6. Temperature Cycle

Sequence	1	2	3	4
Temp.(°C)	-40±3	Shift time	+125±3	Shift time
Time (min.)	30	5 max.	30	5 max.

#### Attention:

This datasheet is downloaded from the website of Murata Manufacturing Co., Ltd. Therefore, it's specifications are subject to change or our products in it may be discontinued without advance notice. Please check with our sales representatives or product engineers before ordering.

#### 4.8 High Temperature Load Life

Full rated continuous working voltage not exceeding 5Vdc should be applied intermittently between terminal #1 and terminal #3 of the rotary position sensor, 1.5 hours on and 0.5 hours off, for 1000±8 hours in total in a chamber at a temperature of 85±2°C. After removing from the chamber, the rotary position sensor should be kept in the dry box for 1~2 hours.

#### 4.9 Rotational life (reciprocal motion)

The adjustment rotor should be continuously rotated within ±110° of effective electrical rotational angle, at the rate of 3 cycle for 1 second for 1M cycles under the condition of 25±2°C of temperature without loading. Then, the rotary position sensor should be kept in the dry box for 10±5 minutes.

#### 4.10 Vibration

The rotary position sensor should be log-swept by the sine oscillatory wave of the maximum amplitude 1.5mm, Acceleration 98m/s<sup>2</sup> (10G) under the condition of the vibration frequency between 10Hz and 2kHz. In 1 cycle which is vibrated for each 20 minutes in the 3 direction of x, y, and z., 12 cycles should be applied during 12 hours in total. Then, the rotary position sensor should be kept in the dry box for 1~2 hours.

#### 4.11 Shock

The rotary position sensor should be applied the following shock test, : Half sine wave with the peak acceleration 14,700m/s<sup>2</sup> (1,500G) max, can be applied in each 3 times (total 18 times) in the 3 direction of x, y, and z with bidirectional. Then, the rotary position sensor should be kept in the dry box for 1~2 hours

#### 4.12 Resistance to soldering heat.

The rotary position sensor should be soldered by reflow soldering method according to the standard soldering Condition (refer to the below table). Then, the rotary position sensor should be kept in the dry box for 24 +8/-0 hours.

Table 7. Soldering heat

Pre-heating		Heating		Peak	Cycle of reflow
Temp.(°C)	Time(sec.)	Temp.(°C)	Time(sec.)	Temp.(°C)	
150~180	60~120	Over 230	30~60	260 +5/-0	2

#### 4.13 Vertical strength of the rotor

The rotary position sensor should be holding. The force of 10N (Ref.: 1.0kgf) should be applied to the rotor in vertical direction of the axes of rotor for 10 seconds.

#### 4.14 Edgewise strength of the rotor

The rotary position sensor should be holding. The vertical shaft should be inserted to the rotor. The force of 3N (Ref.: 306gf) should be applied to vertical shaft in vertical direction of the axes of vertical shaft.

#### 4.15 Solderability

All terminals where is 1.3mm from the point of the terminal of the rotary position sensor should be dipped into the flux for 3 sec. and dipped into the solder bath at a temperature of 245±3°C for 3.0±0.5 seconds.

#### Attention:

This datasheet is downloaded from the website of Murata Manufacturing Co., Ltd. Therefore, it's specifications are subject to change or our products in it may be discontinued without advance notice. Please check with our sales representatives or product engineers before ordering.



## 5. Packing information

### 5.1 Part Number and packing

SVM4A103A0L17B00 Bulk : 100pcs/pack

SVM4A103A0L17R00 Taping : 500pcs/reel

### 5.2 Taping Specification

#### 5.2.1 Plastic Tape Dimensions

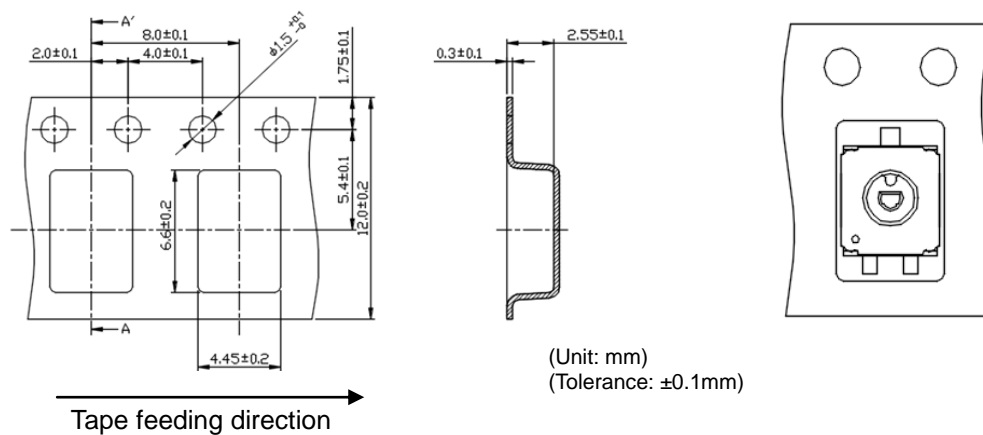

Fig.7 Taping Dimension

#### 5.2.2 Reel dimension

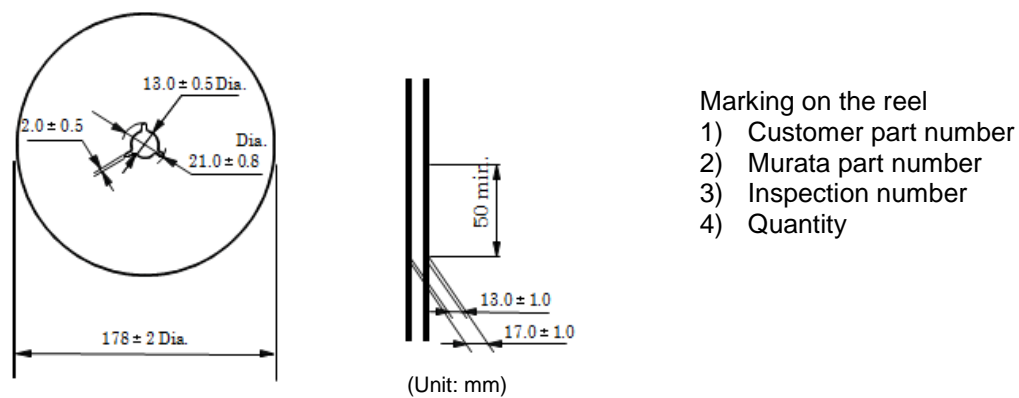

Fig.8 Reel Dimension

#### Attention:

This datasheet is downloaded from the website of Murata Manufacturing Co., Ltd. Therefore, its specifications are subject to change or our products in it may be discontinued without advance notice. Please check with our sales representatives or product engineers before ordering.

## 6. ⚠Caution

### 6.1 Limitation of Applications

Please do not use in the applications listed below which require a high reliability to prevent the defects which might cause a damage to the Peoples' life and/or property.

- 1) Aircraft equipment
- 2) Aerospace equipment
- 3) Undersea equipment
- 4) Power plant control equipment
- 5) Medical equipment
- 6) Transportation equipment (trains, ships, etc.)
- 7) Traffic signal equipment
- 8) Disaster prevention / crime prevention equipment
- 9) Data-processing equipment
- 10) Military equipment (regardless of directly/indirectly)
- 11) Security device/system
- 12) Outside-usage, in which the sensor is exposed to splashes or dusts

Application of similar complexity and/or reliability requirement to the applications listed in the above

### 6.2 Fail-Safe

Please make sure to provide an appropriate fail-safe function on your product to prevent a second damage that may be caused by the abnormal function or the failure of our product.

### 6.3 Notice in design and usage

#### 6.3.1 Soldering

- 1) Standard soldering condition (Lead-free solder : Sn-3Ag-0.5Cu)

➤Reflow soldering

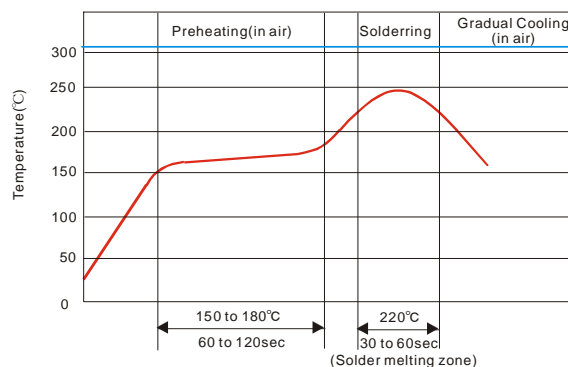

#### Soldering iron

Temperature of tip	: 350±10°C max.
Soldering time	: 3 sec. max. / 1 terminal
Diameter of tip	: 3mm Dia. max.
Wattage of iron	: 30W max.

\*Peak temperature : 245±3°C

\*Cycle of reflow : 2 time

\* Recommended cream sold

Fig.9 Reflow chart

Before using other soldering conditions than those listed above, please consult with Murata factory representative prior to using. If the soldering conditions are not suitable, e.g., excessive time and/or excessive temperature, the rotary position sensor may deviate from the specified characteristics.

- 2) The soldering iron should not come in contact with the case of the rotary position sensor. If such contact does occur, the rotary position sensor may be damaged.

#### Attention:

This datasheet is downloaded from the website of Murata Manufacturing Co., Ltd. Therefore, it's specifications are subject to change or our products in it may be discontinued without advance notice. Please check with our sales representatives or product engineers before ordering.

- 3) Rotary position sensor is designed for the purpose of soldering. If you intend to connect with conductive adhesive or other method, please consult with Murata factory representative prior to using.
- 4) Rotary position sensor is not seated construction. So, when soldering, please pay your attention to prevent flux coming into the rotary position sensor.

### 6.3.2 Cleaning

Cannot be cleaned by any solvents due to the open construction.

### 6.3.3 Operating environmental conditions

1) Uncontrolled mechanical force except usual rotation on the hollow rotor of product, may cause big change of electrical characteristic, big increase of rotational torque or mechanical damage of product. Therefore, please pay your attention on the following points for your design.

1. The fixing method of product must be soldering by the terminals of product. And please do not fix by screw cramping of supporting board which might cause mechanical deformation of product.

2. Your connecting shaft must be sustained by your bearing and any uncontrolled force should not apply on the hollow rotor of product.

2) Do not use the rotary position sensor under the conditions listed below. If you use the rotary position sensor in the conditions listed below, please consult with Murata factory representative prior to using.

1. Corrosive gasses atmosphere (Ex. Cl<sub>2</sub>, H<sub>2</sub>S, NH<sub>3</sub>, SO<sub>2</sub>, NO<sub>x</sub>, etc.)
2. In liquid (Ex. water, oil, medical liquid, organic solvent, etc.)
3. Dusty / dirty atmosphere
4. Direct sunlight
5. Static voltage nor electric / magnetic fields
6. Direct sea breeze
7. Other variations of the above

## 6.4 Notice in Storage

### 6.4.1 Storage conditions

1) To ensure the solderability of the terminal, store that the temperature is -10°C~+40°C and the relative humidity is 30~85%RH, and use within six months after delivery. If you are going to use a product which has been stored for more than six months, please check its solderability beforehand.

2) Do not store in or near corrosive gases.

3) Do not store under direct sunlight.

## 6.5 Notice in Circuit design and other

### 6.5.1 Connecting impedance

Rotary position sensor is designed the condition shown on Fig-1, that is connecting the output terminal and A/D port of the microprocessor directly. In other words, connecting impedance presuppose certain M ohm and the contact resistance are set high. Therefore, please make sure the connecting impedance is to be more than 1M ohm.

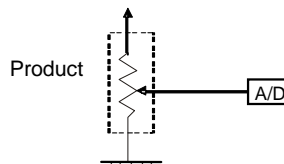

Fig.10 Circuit Diagram

---

### Attention:

This datasheet is downloaded from the website of Murata Manufacturing Co., Ltd. Therefore, its specifications are subject to change or our products in it may be discontinued without advance notice. Please check with our sales representatives or product engineers before ordering.

#### 6.5.2 Noise Suspension

To minimize the processing error which occurs in rare cases, when data is installed through the product and noise influence from wiper contact and/or outside, please note the following points and program rotary position sensor, the rotary position sensor may deviate from the specified characteristics.

- 1) Data install should be done plural times and applied the mean value.
- 2) Data considered as error should be invalid.
- 3) Data should be re-installed if mistrust occurs.

#### 6.5.3 Cautions to use grease or oil

In case of using grease or oil on connecting shaft or gear which are connected to the rotary position sensor, please prevent grease or oil coming into the rotary position sensor. If grease or oil puts into the rotary position sensor, the rotary position sensor may deviate from the specified characteristics.

### 6.6 Other

- 1) Please make sure that your product has been evaluated in view of your specifications with our product being mounted to your product.
- 2) You are requested not to use our product deviating from the agreed specifications.
- 3) Please return one copy of this product specification with your signature of receipt. If the copy is not returned within three months, this product specification will be deemed to have been received.
- 4) We consider it not appropriate to include any terms and conditions with regard to the business transaction in the product specifications, drawings or other technical documents. Therefore, if your technical documents as above include such terms and conditions such as warranty clause, product liability clause, or intellectual property infringement liability clause, they will be deemed to be invalid.

---

#### Attention:

This datasheet is downloaded from the website of Murata Manufacturing Co., Ltd.  
Therefore, it's specifications are subject to change or our products in it may be discontinued without advance notice.  
Please check with our sales representatives or product engineers before ordering.

## X-ON Electronics

Largest Supplier of Electrical and Electronic Components

*Click to view similar products for [Precision Potentiometers](#) category:*

*Click to view products by [Murata](#) manufacturer:*

Other Similar products are found below :

[578002M9648](#) [70J1G032S202A](#) [176FL1-284](#) [F78SB102-M257](#) [3548H-1AA-103B](#) [485025M9267](#) [MH12B-10L-10K](#) [578005M9656](#)  
[72N4N048S203W](#) [RO200SF1C103](#) [114BF2A102-L774](#) [200FL1-199](#) [78FL1-397](#) [78MKV-128](#) [501-0004](#) [501-0018](#) [SE15303-352-T4](#)  
[284TCBF103A26A1](#) [RO34SF1B502](#) [200FL1-260](#) [4205R10KL.5](#) [3548H-1AB-502A](#) [157-0237](#) [1521R10KL.3](#) [284TBBK103A26B1](#) [SP22G-](#)  
[500](#) [DC22-10-100](#) [JC22S 1K 0.5%](#) [RCL-100](#) [RCL-200](#) [380C2750K](#) [3548H-1AA-102B](#) [380C2500K](#) [3590P-2-203L](#) [3590P-1-103L](#) [3547S-](#)  
[1AA-202A](#) [534B1250JC](#) [3543S-1-202L](#) [3543S-1-102L](#) [3543S-1-502L](#) [3545S-1-103L](#) [3549S-2AA-102/102A](#) [P3265](#) [P3270](#) [P3275](#) [P3280](#)  
[P3285](#) [P3290](#) [AR200KL.25](#) [6637S-1-102](#)