

Crystal Units/Crystal Oscillators

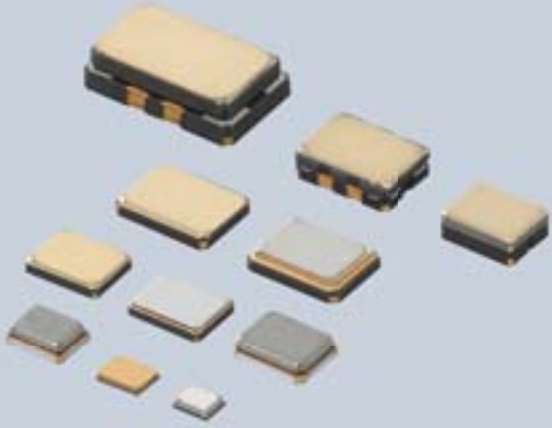



EU RoHS Compliant

- All the products in this catalog comply with EU RoHS.
- EU RoHS is "the European Directive 2011/65/EU on the Restriction of the Use of Certain Hazardous Substances in Electrical and Electronic Equipment."
- For more details, please refer to our web page, "Murata's Approach for EU RoHS" (<https://www.murata.com/en-eu/support/compliance/rohs>).

● Part Numbering

Crystal Unit

(Part Number)

XR	C	GB	24M000	F	0	L	00	R0
①	②	③	④	⑤	⑥	⑦	⑧	⑨

① Product ID

Product ID	
XR	Crystal Unit

② Lead Style

Code	Lead Style
C/T	SMD

③ Size · Structure

Code	Size · Structure
TD	1210 (STD) Metal Sealing
FD	1612 (STD) Metal Sealing
MD	1612 (Low Profile) Metal Sealing
GB	2016 (STD) Resin Sealing
PB	2016 (Low Profile) Resin Sealing
HA	2520 Resin Sealing
HH	2520 Metal Sealing
HJ	2520 Seam Sealing
JH	3225 Metal Sealing
JK	3225 Seam Sealing
LH	5032 Metal Sealing
LK	5032 Seam Sealing

④ Nominal Center Frequency

Expressed by six-digit alphanumeric. The unit is in hertz (Hz).
 Decimal point is expressed by capital letter "M".

⑤ Overtone Order

Code	Overtone Order
F	Fundamental
K	Customized Fundamental

⑥ Frequency Tolerance

Code	Frequency Tolerance
0	±100ppm
1	±10ppm
2	±20ppm
3	±30ppm
4	±45ppm/±40ppm* ¹
5	±50ppm
A	±25ppm/±15ppm* ²
Y	Total* ³ ±20ppm

*1 *2 When ③ is "HH" or "JK"

*3 Including Initial Tolerance+Temperature
 Characteristics+Aging+Reflow

⑦ Frequency Shift by Temperature

Code	Frequency Shift by Temperature
A	±100ppm max. (Automotive Grade)
G	±50ppm (Car Multimedia Grade)
L	±50ppm min.
M	±40ppm
N	±25ppm or 30ppm
P	±20ppm
H/Q	±10ppm to ±15ppm/±10ppm to ±19ppm* ¹
Z	±100ppm (for Industrial)

*1 When ③ is "HH" or "JK"

⑧ Individual Specification

Code	
**	Two-digit alphanumerics express Individual Specification.

00: Standard specification type.

⑨ Packaging (Quantity and Plastic taping reel diameter are expressed by one-digit number in "**")

Code	Packaging
R*/E*/J*/P*	Plastic Taping

Crystal Oscillators

for Industrial



We offer a varied lineup of TCXO (Temperature compensated crystal oscillator)/VC-TCXO (Voltage-controlled temperature compensated crystal oscillator) based on highly reliable crystal units, superior temperature compensation and adjusting method fostered by our long experience and expertise.

Features

1. Excellent frequency stability over temperature
2. Low profile
3. Low supply voltage
4. SMD type (Reflow soldering available)
5. The series complies to RoHS directive, being lead-free (phase 3).

Applications

1. Business radios
2. GPS (GNSS) systems
3. Small cells
4. Wireless devices



XNCHH
(TTS27NSC-A7)
10.0000–52.0000MHz
XTCHH
(TTS27VSC-A7)
10.0000–52.0000MHz

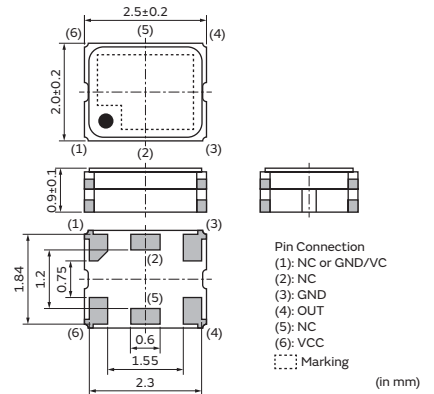

XNCJH
(TTS18NSH-A7)
10.0000–52.0000MHz
XTCJH
(TTS18VSH-A7)
10.0000–52.0000MHz

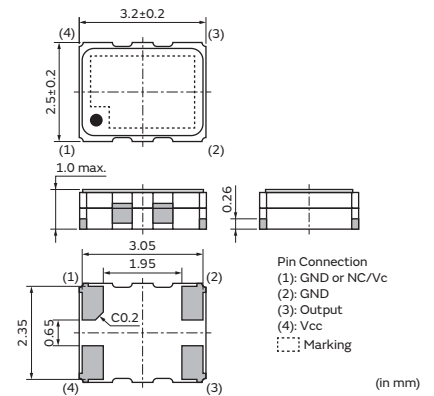

XTCLH_J
(TTS14VSH/TTS14VCH)
10.0000–50.0000MHz

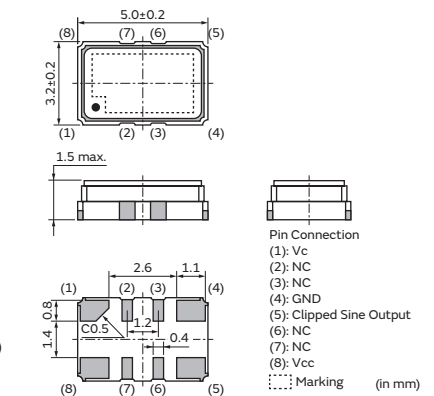

Series

Series	Type	Size	Package	Frequency (MHz)	Frequency Tolerance (ppm max.) [at 25°C±3°C]	Frequency Shift by Temperature (ppm max.) [Standard Condition: +25°C]	Frequency Aging (ppm max./Year)	Operating Temperature Range (°C)	VC Function
XNCHH	TTS27NSC-A7	2520	Metal	10.0000 to 52.0000	±1.0	±0.5	±1.0	-30 to +85°C	—
XTCHH	TTS27VSC-A7								○
XNCJH	TTS18NSH-A7	3225							—
XTCJH	TTS18VSH-A7								—
XTCLH_J	TTS14VSH	5032	Metal	10.0000 to 50.0000	±0.5	±0.2	±0.5	-40 to +85°C	○
	TTS14VCH								○

Part Number List

<XNCHH>

Part Number	Type	Frequency (MHz)	Frequency Tolerance (ppm max.) [at 25°C±3°C]	Frequency Shift by Temperature (ppm max.) [Standard Condition: +25°C]	Frequency Aging (ppm max./Year)	Current Consumption (mA max.)	Frequency Controlled Range (ppm)
XNCHH10M000TJEA2P0	TTS27NSC-A7	10.0000	±1.0	±0.5 (-30 to +85°C)	±1.0	2	-
XNCHH15M300TJEA0P0	TTS27NSC-A7	15.3000	±1.0	±0.5 (-30 to +85°C)	±1.0	2	-
XNCHH16M368TJEA4P0	TTS27NSC-A7	16.3680	±1.0	±0.5 (-30 to +85°C)	±1.0	2	-
XNCHH16M800TJEA3P0	TTS27NSC-A7	16.8000	±1.0	±0.5 (-30 to +85°C)	±1.0	2	-
XNCHH19M200TJEC1P0	TTS27NSC-A7	19.2000	±1.0	±0.5 (-30 to +85°C)	±1.0	2	-
XNCHH26M000TJEE5P0	TTS27NSC-A7	26.0000	±1.0	±0.5 (-30 to +85°C)	±1.0	2	-
XNCHH28M800TJEA1P0	TTS27NSC-A7	28.8000	±1.0	±0.5 (-30 to +85°C)	±1.0	2	-
XNCHH32M000TJEB5P0	TTS27NSC-A7	32.0000	±1.0	±0.5 (-30 to +85°C)	±1.0	2	-
XNCHH38M400TJEB3P0	TTS27NSC-A7	38.4000	±1.0	±0.5 (-30 to +85°C)	±1.0	2	-
XNCHH52M000TJEA1P0	TTS27NSC-A7	52.0000	±1.0	±0.5 (-30 to +85°C)	±1.0	2	-

<XTCHH>

Part Number	Type	Frequency (MHz)	Frequency Tolerance (ppm max.) [at 25°C±3°C]	Frequency Shift by Temperature (ppm max.) [Standard Condition: +25°C]	Frequency Aging (ppm max./Year)	Current Consumption (mA max.)	Frequency Controlled Range (ppm)
XTCHH10M000TJEA3P0	TTS27VSC-A7	10.0000	±1.0	±0.5 (-30 to +85°C)	±1.0	2	±5 min. to ±15 max.
XTCHH15M300TJEA2P0	TTS27VSC-A7	15.3000	±1.0	±0.5 (-30 to +85°C)	±1.0	2	±5 min. to ±15 max.
XTCHH16M800TJEA2P0	TTS27VSC-A7	16.8000	±1.0	±0.5 (-30 to +85°C)	±1.0	2	±5 min. to ±15 max.
XTCHH19M200TJEB4P0	TTS27VSC-A7	19.2000	±1.0	±0.5 (-30 to +85°C)	±1.0	2	±5 min. to ±15 max.
XTCHH20M950TJEA0P0	TTS27VSC-A7	20.9500	±1.0	±0.5 (-30 to +85°C)	±1.0	2	±5 min. to ±15 max.
XTCHH21M250TJEA0P0	TTS27VSC-A7	21.2500	±1.0	±0.5 (-30 to +85°C)	±1.0	2	±5 min. to ±15 max.
XTCHH26M000TJEB1P0	TTS27VSC-A7	26.0000	±1.0	±0.5 (-30 to +85°C)	±1.0	2	±5 min. to ±15 max.
XTCHH28M800TJEA0P0	TTS27VSC-A7	28.8000	±1.0	±0.5 (-30 to +85°C)	±1.0	2	±5 min. to ±15 max.
XTCHH38M400TJEA1P0	TTS27VSC-A7	38.4000	±1.0	±0.5 (-30 to +85°C)	±1.0	2	±5 min. to ±15 max.
XTCHH52M000TJEA1P0	TTS27VSC-A7	52.0000	±1.0	±0.5 (-30 to +85°C)	±1.0	2	±5 min. to ±15 max.

<XNCJH>

Part Number	Type	Frequency (MHz)	Frequency Tolerance (ppm max.) [at 25°C±3°C]	Frequency Shift by Temperature (ppm max.) [Standard Condition: +25°C]	Frequency Aging (ppm max./Year)	Current Consumption (mA max.)	Frequency Controlled Range (ppm)
XNCJH10M000TJEA8P0	TTS18NSH-A7	10.0000	±1.0	±0.5 (-30 to +85°C)	±1.0	2	-
XNCJH15M300TJEA0P0	TTS18NSH-A7	15.3000	±1.0	±0.5 (-30 to +85°C)	±1.0	2	-
XNCJH16M800TJEA1P0	TTS18NSH-A7	16.8000	±1.0	±0.5 (-30 to +85°C)	±1.0	2	-
XNCJH19M200TJEA5P0	TTS18NSH-A7	19.2000	±1.0	±0.5 (-30 to +85°C)	±1.0	2	-
XNCJH26M000TJEB4P0	TTS18NSH-A7	26.0000	±1.0	±0.5 (-30 to +85°C)	±1.0	2	-
XNCJH28M800TJEA1P0	TTS18NSH-A7	28.8000	±1.0	±0.5 (-30 to +85°C)	±1.0	2	-
XNCJH38M400TJEA3P0	TTS18NSH-A7	38.4000	±1.0	±0.5 (-30 to +85°C)	±1.0	2	-
XNCJH52M000TJEA0P0	TTS18NSH-A7	52.0000	±1.0	±0.5 (-30 to +85°C)	±1.0	2	-

<XTCJH>

Part Number	Type	Frequency (MHz)	Frequency Tolerance (ppm max.) [at 25°C±3°C]	Frequency Shift by Temperature (ppm max.) [Standard Condition: +25°C]	Frequency Aging (ppm max./Year)	Current Consumption (mA max.)	Frequency Controlled Range (ppm)
XTCJH10M000TJEB0P0	TTS18VSH-A7	10.0000	±1.0	±0.5 (-30 to +85°C)	±1.0	2	±5 min. to ±15 max.
XTCJH15M300TJEA3P0	TTS18VSH-A7	15.3000	±1.0	±0.5 (-30 to +85°C)	±1.0	2	±5 min. to ±15 max.
XTCJH16M800TJEB0P0	TTS18VSH-A7	16.8000	±1.0	±0.5 (-30 to +85°C)	±1.0	2	±5 min. to ±15 max.
XTCJH19M200TJEB6P0	TTS18VSH-A7	19.2000	±1.0	±0.5 (-30 to +85°C)	±1.0	2	±5 min. to ±15 max.
XTCJH26M000TJEB4P0	TTS18VSH-A7	26.0000	±1.0	±0.5 (-30 to +85°C)	±1.0	2	±5 min. to ±15 max.
XTCJH28M800TJEA0P0	TTS18VSH-A7	28.8000	±1.0	±0.5 (-30 to +85°C)	±1.0	2	±5 min. to ±15 max.
XTCJH38M400TJEA3P0	TTS18VSH-A7	38.4000	±1.0	±0.5 (-30 to +85°C)	±1.0	2	±5 min. to ±15 max.
XTCJH52M000TJEA5P0	TTS18VSH-A7	52.0000	±1.0	±0.5 (-30 to +85°C)	±1.0	2	±5 min. to ±15 max.

<XTCLH_J>

Part Number	Type	Frequency (MHz)	Frequency Tolerance (ppm max.)	Frequency Shift by Temperature (ppm max.) [Standard Condition: +25°C]	Frequency Aging (ppm max./Year)	Frequency Controlled Range (ppm)	Output
XTCLH19M200TJC3PO	TTS14VSH	19.2000	±0.5ppm max. (25±3°C)	±0.2(-40 to +85°C)	±0.5	±3min. to ±6max.	Clipped Sine Wave
XTCLH25M000TJA5PO	TTS14VSH	25.0000	±0.5ppm max. (25±3°C)	±0.2(-40 to +85°C)	±0.5	±3min. to ±6max.	Clipped Sine Wave
XTCLH26M000TJA6PO	TTS14VSH	26.0000	±0.5ppm max. (25±3°C)	±0.2(-40 to +85°C)	±0.5	±3min. to ±6max.	Clipped Sine Wave
XTCLH20M000CYJB6PO	TTS14VCH	20.0000	±1.12ppm max. (25±2°C)	±0.28(-40 to +85°C)	±0.8	±4.12min. to ±9max.	CMOS
XTCLH40M000CYJC4PO	TTS14VCH	40.0000	±1.12ppm max. (25±2°C)	±0.28(-40 to +85°C)	±0.8	±4.12min. to ±9max.	CMOS
XTCLH10M000CHJA1PO	TTS14VCH	10.0000	±0.5ppm max. (25±3°C)	±0.28(-40 to +85°C)	±0.5	±3min. to ±6max.	CMOS
XTCLH20M000CHJA0PO	TTS14VCH	20.0000	±0.5ppm max. (25±3°C)	±0.28(-40 to +85°C)	±0.5	±3min. to ±6max.	CMOS
XTCLH40M000CHJA0PO	TTS14VCH	40.0000	±0.5ppm max. (25±3°C)	±0.28(-40 to +85°C)	±0.5	±3min. to ±6max.	CMOS
XTCLH50M000CHJA3PO	TTS14VCH	50.0000	±0.5ppm max. (25±3°C)	±0.28(-40 to +85°C)	±0.5	±3min. to ±6max.	CMOS

Standard Land Pattern Dimensions

XNCHH (TTS27NSC-A7)
 XTCHH (TTS27VSC-A7)

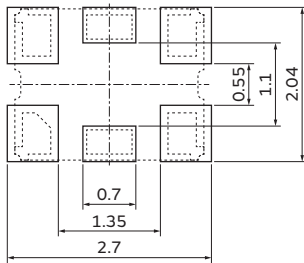

(in mm)

XNCJH (TTS18NSH-A7)
 XTCJH (TTS18VSH-A7)

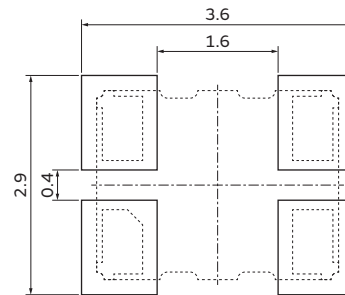

(in mm)

XTCLH_J (TTS14VSH/TTS14VCH)

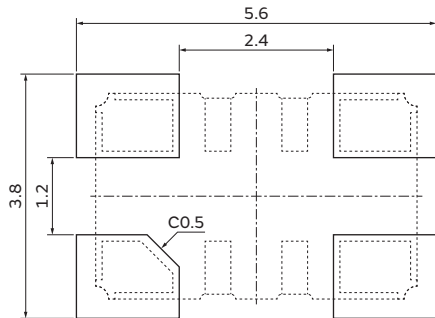

(in mm)

Notice -Crystal Oscillators for Industrial-

Notice (Soldering and Mounting)

1.1. Soldering Condition

(1) Reflow

Please mount components on a circuit board by the reflow soldering.

Flux: Please use rosin based flux; but do not use water soluble flux.

Solder: Please use solder (Sn-3.0Ag-0.5Cu) under the following condition.

Standard thickness of soldering paste: 0.10 to 0.15mm

	Condition	
Pre-heating	150 to 200°C	120 sec. max.
Heating	220°C min.	55 sec. max.
Peak Temperature	255°C min. 260°C max.	10 sec. max.

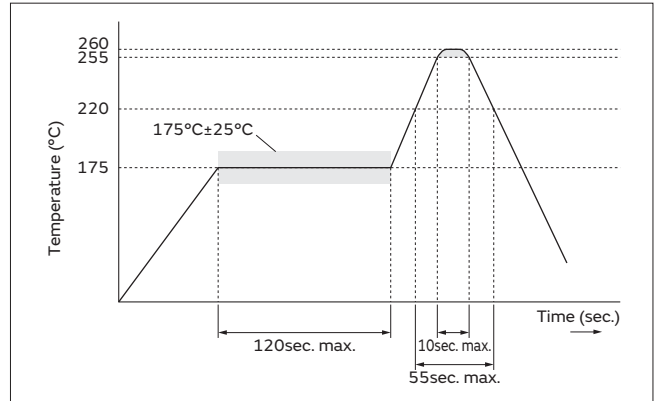

(2) Soldering Iron

If compelled to mount the component by using a soldering iron, please do not directly touch the component with the soldering iron. The component terminals or metal lid may be damaged if excessive thermal stress is applied.

	Condition
Pre-heating	150°C 60 sec.
Heating of the Soldering Iron	350°C max.
Watt	30W max.
Shape of the Soldering Iron	ø3mm max.
Soldering Time	5 sec. max.
Solder	Sn-3.0Ag-0.5Cu

1.2. Optimum Solder Amount for Soldering

Please keep the solder volume below the height of the substrate. When exceeding the substrate, damage of sealing part between the metal cap and the substrate may occur.

2. Wash

The component cannot withstand washing.

3. Notice for Mounting

The component is recommended with placement machines employing optical placement capabilities. The component might be damaged by mechanical force depending on placement machine and condition. Make sure that you have evaluated by using placement machines before going into mass production. Do not use placement machines employing mechanical positioning. Please contact Murata for details beforehand.

Continued on the following page. ↗

Notice -Crystal Oscillators for Industrial-

Continued from the preceding page. ↘

Notice (Storage and Operating Condition)

1. Product Storage Condition

Please store the products in a room where the temperature/humidity is stable. And avoid such places where there are large temperature changes. Please store the products under the following conditions:

Temperature: -10 to + 40 degrees C

Humidity: 15 to 85% R.H.

2. Expire Date on Storage

Expiration date (shelf life) of the products is 6 months after delivery under the conditions of an unopened package. Please use the products within 6 months after delivery. If you store the products for a long time (more than 6 months), use carefully because the products may be degraded in solderability and/or rusty.

Please confirm solderability and characteristics for the products regularly.

3. Notice on Product Storage

(1) Please do not store the products in a chemical atmosphere (Acids, Alkali, Bases, Organic gas, Sulfides and so on), because the characteristics may be reduced in quality, and/or be degraded in the solderability due to storage in a chemical atmosphere.

(2) Please do not put the products directly on the floor without anything under them to avoid damp places and/or dusty places.

(3) Please do not store the products in the places under direct sunlight, heat and vibration.

(4) Please use the products immediately after the package is opened, because the characteristics may be reduced in quality, and/or be degraded in solderability due to storage under poor conditions.

(5) Please do not drop the products to avoid cracking the crystal element.

4. Other

Conformal coating or washing of the component is not acceptable.

Please be sure to consult with our sales representative or engineer whenever and prior to using the products.

Notice (Rating)

The component may be damaged if excess mechanical stress is applied.

Notice (Handling)

1. Be sure to provide an appropriate fail-safe function on your product to prevent a second damage that may be caused by the abnormal function or the failure of our product.

2. Please do not use these products in the following applications in transportation equipment (vehicles, trains, ships, etc.).
(example: engine control, brake control, steering control, body control.)

Packaging -Crystal Oscillators for Industrial-

Dimensions of Taping

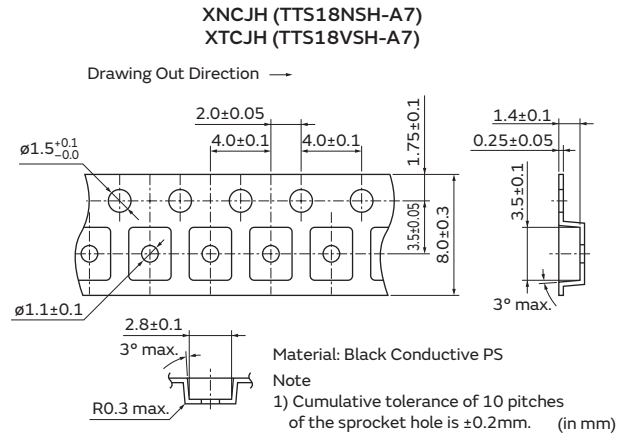
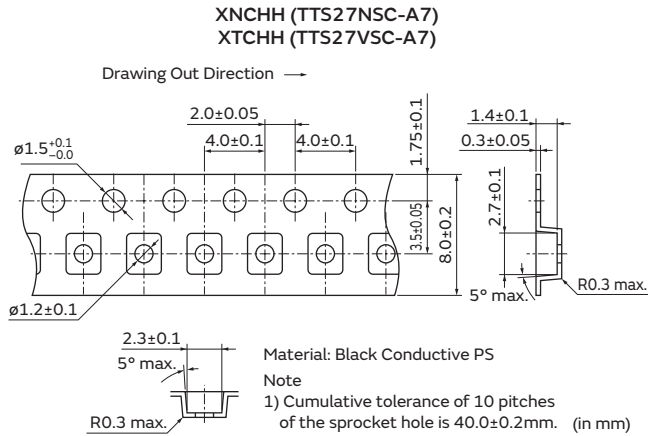

Minimum Quantity/Dimensions of Reel

Plastic Tape $\phi 180$ mm

3,000

(pcs.)

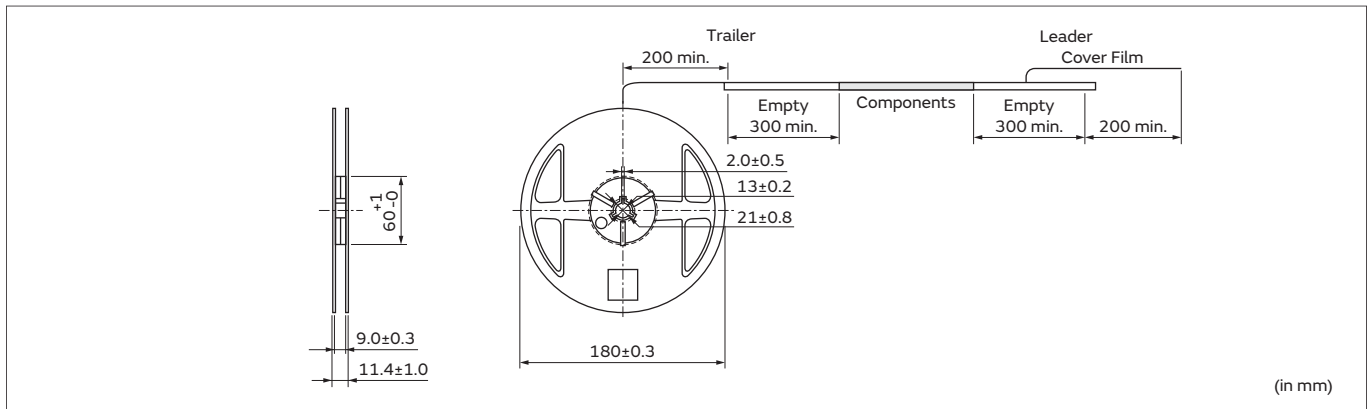

Packaging -Crystal Oscillators for Industrial-

Dimensions of Taping

XTCLH_J (TTS14VSH/TTS14VCH)

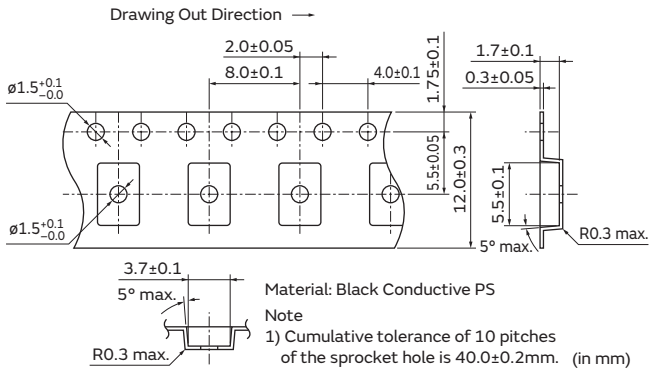

Minimum Quantity/Dimensions of Reel

Plastic Tape $\phi 255$ mm

2,000

(pcs.)

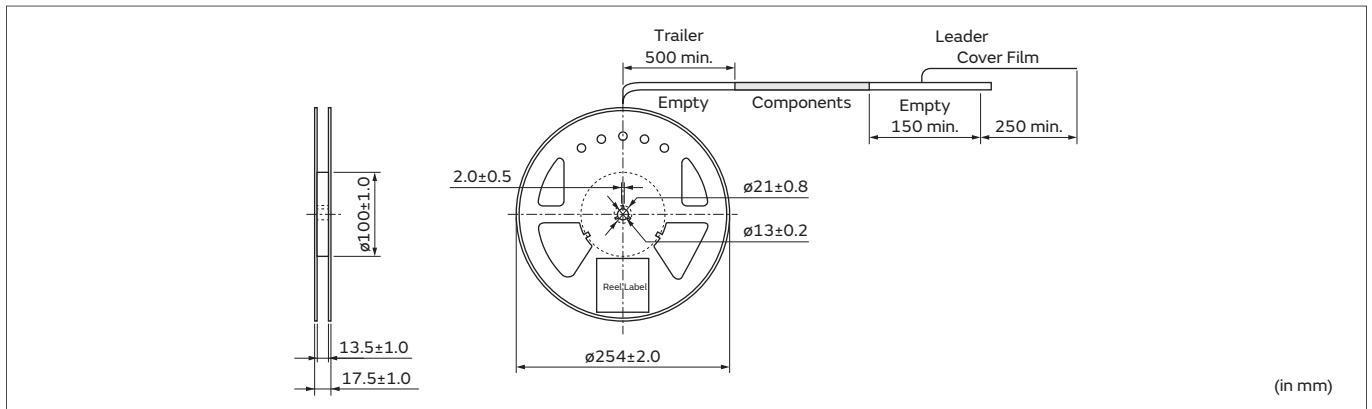

Measuring Circuit of Crystal Units

Measuring Circuit

1. Frequency Measuring Method

The load resonance frequency (Lower frequency of the two given when the electrical impedance of the component becomes resistant near its resonance point) is measured by network analyzer (KEYSIGHT E5100A or the equivalent) and the circuit in Figure 1. DUT is shown in Figure 2, and the value of Cs refers to the load capacitance value in specifications.

2. Equivalent Series Resistance

The equivalent series resistance (ESR) is measured by network analyzer (KEYSIGHT E5100A or equivalent) and the circuit in Figure 1. DUT is shown in Figure 3.

3. Measuring Condition

Standard conditions for measurement shall be $+25\pm 3^{\circ}\text{C}$ temperature and humidity of 45 to 85%R.H.

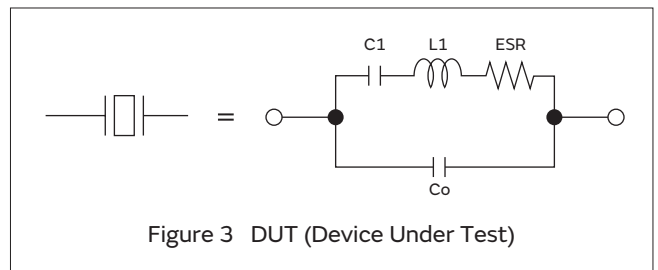
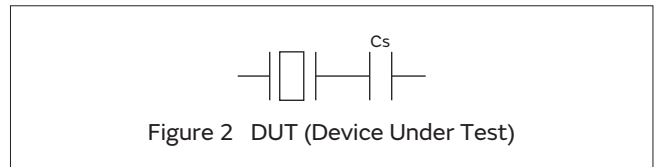
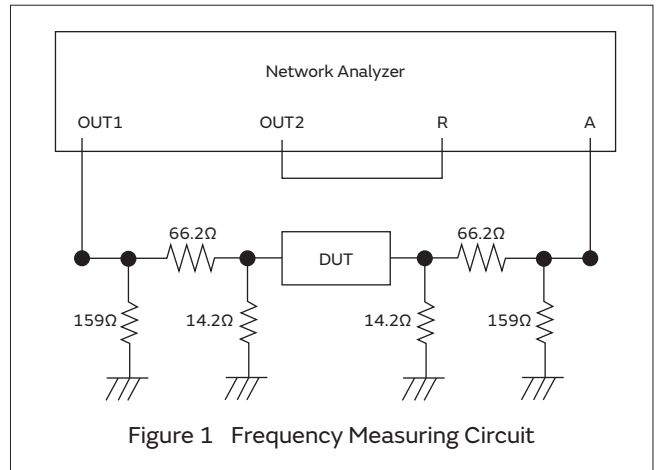

Global Locations

For details please visit www.murata.com



⚠ Note

1 Export Control

For customers outside Japan:

No Murata products should be used or sold, through any channels, for use in the design, development, production, utilization, maintenance or operation of, or otherwise contribution to (1) any weapons (Weapons of Mass Destruction [nuclear, chemical or biological weapons or missiles] or conventional weapons) or (2) goods or systems specially designed or intended for military end-use or utilization by military end-users.

For customers in Japan:

For products which are controlled items subject to the "Foreign Exchange and Foreign Trade Law" of Japan, the export license specified by the law is required for export.

2 Please contact our sales representatives or product engineers before using the products in this catalog for the applications listed below, which require especially high reliability for the prevention of defects which might directly damage a third party's life, body or property, or when one of our products is intended for use in applications other than those specified in this catalog.

- ① Aircraft equipment
- ② Aerospace equipment
- ③ Undersea equipment
- ④ Power plant equipment
- ⑤ Medical equipment
- ⑥ Transportation equipment (vehicles, trains, ships, etc.)
- ⑦ Traffic signal equipment
- ⑧ Disaster prevention / crime prevention equipment
- ⑨ Data-processing equipment
- ⑩ Application of similar complexity and/or reliability requirements to the applications listed above

3 Product specifications in this catalog are as of January 2018. They are subject to change or our products in it may be discontinued without advance notice. Please check with our sales representatives or product engineers before ordering. If there are any questions, please contact our sales representatives or product engineers.

4 Please read rating and ⚠CAUTION (for storage, operating, rating, soldering, mounting and handling) in this catalog to prevent smoking and/or burning, etc.

5 This catalog has only typical specifications. Therefore, please approve our product specifications or transact the approval sheet for product specifications before ordering.

6 Please note that unless otherwise specified, we shall assume no responsibility whatsoever for any conflict or dispute that may occur in connection with the effect of our and/or a third party's intellectual property rights and other related rights in consideration of your use of our products and/or information described or contained in our catalogs. In this connection, no representation shall be made to the effect that any third parties are authorized to use the rights mentioned above under licenses without our consent.

7 No ozone depleting substances (ODS) under the Montreal Protocol are used in our manufacturing process.

Murata Manufacturing Co., Ltd.

www.murata.com

muRata
INNOVATOR IN ELECTRONICS

X-ON Electronics

Largest Supplier of Electrical and Electronic Components

Click to view similar products for [TCXO Oscillators](#) category:

Click to view products by [Murata](#) manufacturer:

Other Similar products are found below :

[SiT5000AI-3D-33E0-10.000000X](#) [THD3031035LK280005-10.0M](#) [CVT32-10.000](#) [SIT5356AI-FQ-33E0-25.000000X](#) [SIT5357AI-FQ-33N0-100.000000X](#) [DS32KHZSN+T&R](#) [XTCLH25M000THJA0P0](#) [LFTCXO075793Cutt](#) [LFTCXO077229Cutt](#) [LFPTXO000002Bulk](#) [LFTCXO077228Cutt](#) [LFTCXO077230Cutt](#) [LFTCXO075792Cutt](#) [LFPTXO000001Bulk](#) [LFTCXO063711BULK](#) [LFTCXO063713BULK](#) [LFTCXO063715BULK](#) [LFTCXO063780BULK](#) [LFTCXO070027Cutt](#) [LFTCXO070028Cutt](#) [LFTCXO070033Cutt](#) [LFTCXO070037Cutt](#) [LFTCXO070179Cutt](#) [LFTCXO070180Cutt](#) [LFTCXO007009BULK](#) [DS32KHZST&R](#) [XNCLH20M000CHJA3P0](#) [XNCLH25M000THJA0P0](#) [XNCLH30M720THJA1P0](#) [XTCLH16M384THJA2P0](#) [XTCLH20M000CHJA0P0](#) [XTCLH30M720THJA0P0](#) [NT2016SA-26.000000MHZ-NBG2](#) [SIT1552AI-JE-DCC-32.768E](#) [SIT1566AI-JE-18E-32.768E](#) [SIT1552AI-JF-DCC-32.768D](#) [SIT1566AI-JV-18E-32.768E](#) [SIT5000AICGE-33N0-25.000000X](#) [SiT5021AI-2BE-33VQ200.000000X](#) [SiT5155AI-FK-33E0-10.000000X](#) [SiT5155AI-FK-33VT-10.000000X](#) [SiT5156AI-FK-33E0-25.000000X](#) [SiT5157AI-FK-33N0-100.000000X](#) [7Q16300001](#) [7L-38.400MDG-T](#) [7Z-26.000MDG-T](#) [7Z-26.000MBG-T](#) [LFTCXO075792](#) [LFTCXO075797](#) [LFPTXO000009Bulk](#)