

RevNo	Revision note	Date	Signature
△			

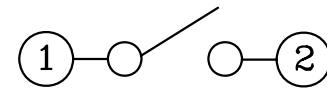

CIRCUIT DIAGRAM

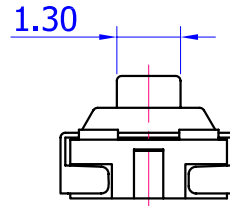
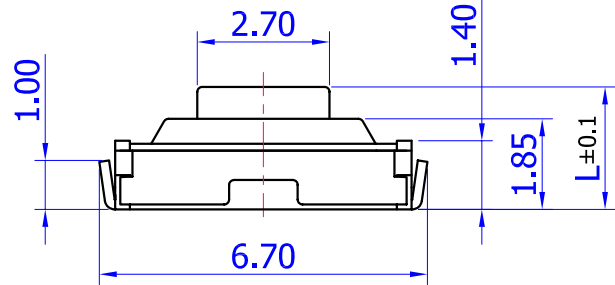
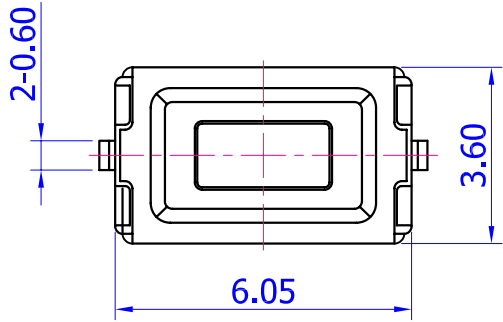
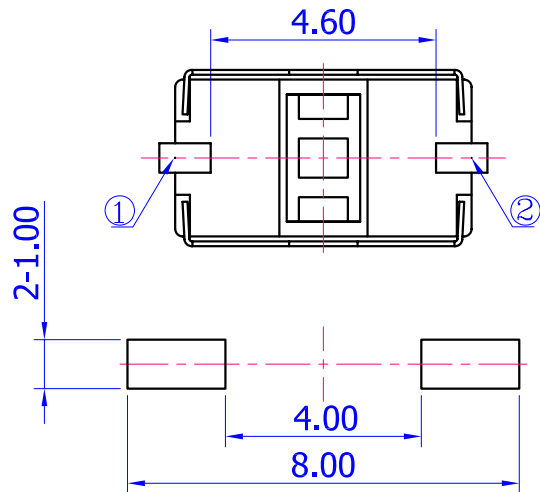

P.C.B SOLDER LAND DIMENSIONS

**NOTE:**

- 1.RATING : DC 12V 50mA
- 2.CONTACT RESISTANCE : 100mΩ MAX
- 3.TRAVEL : 0.25±0.1mm
- 4.GENERAL TOLERANCE : ±0.3mm
- 5.MANUFACTURING SPECIFICATION WOULD BE ACCORDANCE WITH WT0160

JT1107MJ		180±30gf	BLACK	BLACK	2.5mm	50,000 Cycles	
JT1107MWJ	130010000261	250±50gf	BLACK	RED	2.5mm	50,000 Cycles	
MODEL NAME	CODE NO.	O/FORCE	CASE COLOR	STEM COLOR	"L"	LIFE CYCLE	REMARKS

Designed by							
Checked by		Unit	mm	Scale	N/S	Date	2015.06.15
Approved by	Item		Tool	Sheet	Rev.		
	TACTILE SWITCH		Au	1/1	0		
Model	JT 1107J Series		Drawing name		ASSEMBLY		

	SPECIFICATION	PAGE
	TACT SWITCH	1 / 4

1. GENERAL MATTERS

1.1 Application : This specification is applied to low current circuit tactile switch for electronic equipment.

1.2 Operating temperature range : -20 ~ 70°C, 45 ~ 85% RH

1.3 Storage temperature range : -30 ~ 80°C. However, 96 hours maximum for continuous storage over a range -20 ~ -30°C and a range 70 ~ 80°C.

1.4 Test conditions : The standard test conditions shall be 5 ~ 35°C in temperature, 45 ~ 85% RH and 860 ~ 1060mbar in atmospheric pressure.  
Should any doubt arise in judgement, tests shall be conducted at 20±2°C, 65±5% RH and 860 ~ 1060mbar.

2. RATED VOLTAGE AND CURRENT.

As per individual manufactured drawing.

3. ELECTRICAL PERFORMANCE

	PROPERTY	TEST CONDITIONS	PERFORMANCE
3.1	Contact arrangement		* 1 pole, 1 throw.
3.2	Contact resistance	Measured at DC 5V 10mA or by ohmmeter allowing a small current at 1KHz with a load of 150% of the actuating force.	* As per individual manufactured drawing.
3.3	Insulation resistance	DC 100V is applied between terminals and between terminals and earth for 1minute ±5seconds.	* Greater than 100 MΩ.
3.4	Dielectric strength	AC 250V (50 ~ 60Hz) is applied between terminals and between terminals and push for 1 minute.	* No insulation defect shall be observed.
3.5	Bounce	Measured by lightly striking the center of the button stem at a rate of 3 operations/sec...	* less than 10 msec.

						APPD	CHKD	DSGN	TITLE
									DOCUMENT NO.
									WT 0160
ZONE	SYMB	DATE	APPD	CHKD	DSGD				

	SPECIFICATION	PAGE
	TACT SWITCH	2 / 4

#### 4. MECHANICAL PERFORMANCE

	PROPERTY	TEST CONDITIONS	PERFORMANCE
4.1	Actuating force	A gradually increasing load is applied to the center of the button stem.	* As per individual manufactured drawing.
4.2	Return force	After actuating, the load is gradually decreased until the stem returns to its free position.	* 160gf,180gf,250gf,260gf : greater than 50gf. * 100gf,130gf : greater than 30gf.
4.3	Stop strength	A static force of 3 Kgf shall be applied to the direction of operation for 3 seconds.	* Shall be free from mechanical and electrical abnormalities.
4.4	Stem withdrawal force	A static load of 500gf is applied to the direction of pulling for 3 seconds.	* Shall be free from mechanical and electrical degradation.
4.5	Travel		* As per individual manufactured drawing.
4.6	Arrangement of action		* Tactile feed-back.

#### 5. DURABILITY

	PROPERTY	TEST CONDITIONS	PERFORMANCE
5.1	Operating life	The test is conducted according to the below. (1) DC 5V 5mA resistive load. (2) Rate of operation : 60 cycle/min (3) Actuating force : 150% of actuating force (4) Operating cycle : As per individual manufactured drawing.	* Contact resistance : 500mΩ maximum. * Bounce : 20m sec max. * Actuating force : within ± 30% of the initial value. * Insulation resistance : 10 MΩ minimum.

#### 6. WEATHER PROOF

6.1	Cold heat proof	After testing at -30°C for 96hours, the sample is allowed to stand under normal temperature and humidity conditions for 1hour and measurement is performed within 1hour after that. Water drops should be wiped off.	* The requirement in item 3 and 4 shall be satisfied.
-----	-----------------	--	---

						APPD	CHKD	DSGN	TITLE
									DOCUMENT NO.
ZONE	SYMB	DATE	APPD	CHKD	DSGD				WT 0160

	SPECIFICATION	PAGE
	TACT SWITCH	3 / 4

	PROPERTY	TEST CONDITIONS	PERFORMANCE
6.2	Dry heat proof	After testing at 85°C for 96hours, the sample is allowed to stand under normal temperature for 1hour and measurement is performed within 1 hour after that.	* The requirement in item 3 and 4 shall be satisfied.
6.3	Damp heat proof	After testing at 60±2°C and 90 ~ 95% in relative humidity for 96hours, the sample is allowed to stand under normal temperature and humidity conditions for 1hour and measurement is performed within 1hour after that. Water drops should be wiped off.	* Insulation resistance : 10 MΩ minimum.. * Dielectric strength : same as item 3.4. * Contact resistance : same as item 3.2.
6.4	Thermal cycling	<p>After the test conducted under 5 cycles the sample is allowed to stand under normal temperature and humidity conditions for 1 hour, and the measurement is performed within 1 hour.</p>	* The requirement in item 3 and 4 shall be met.

## 7. REFLOW SOLDERING

### 7.1 Reflow soldering conditions

- 1) Preheat ----- 150°C ~ 200°C, 120 ±20 (sec)
- 2) Peak temperature --- 260°C max. 10 (sec)
- 3) Soldering area temperature ----- 217°C, 90 ~ 120 (sec)

						APPD	CHKD	DSGN	TITLE
								L. Y. D	DOCUMENT NO.
ZONE	SYMB	DATE	APPD	CHKD	DSGD				WT 0160

	SPECIFICATION	PAGE
	TACT SWITCH	4 / 4

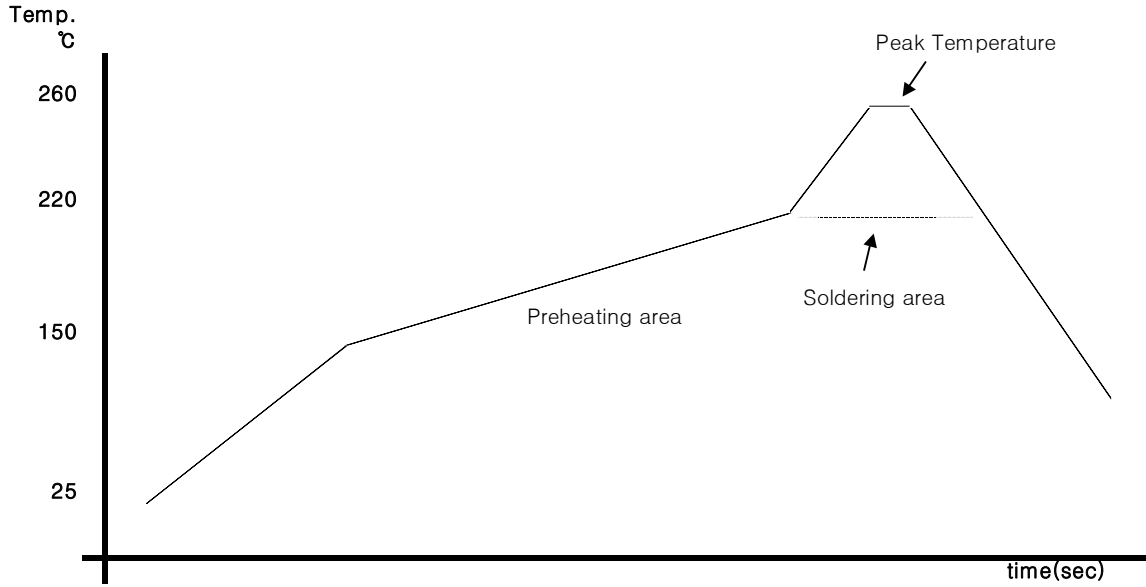

< Temperature profile >

8. Manual soldering

8.1 Soldering temperature ----- 350°C ± 5°C

8.2 Soldering time ----- 5(sec)

						APPD	CHKD	DSGN	TITLE
									DOCUMENT NO.
ZONE	SYMB	DATE	APPD	CHKD	DSGD				WT 0160

# 재 질 증 명 서

## (CERTIFICATION OF MATERIAL)

결 재	작 성	검 토	승 인

일 자            2015.06.19  
DATE

제품명            TACT SWITCH  
ITEM

제품 번호        JT1107MJEM  
MODEL No.

상기 제품은 하기재료를 사용하고 있음을 증명합니다.  
(The above item is certified to use with following materials.)

No.	구성부품명 (Part name)	원재료 (Material)				난연성 (Flame class)	UL (File No.)	색상 (Color)
		Material name	Treatment	Manufacturer	Nationality			
1	CASE	LCP		POLYPLASTICS	JAPAN	UL 94V-0	E106764	BLACK
2	TERMINAL	BRASS	Ag Plating	CHINALCO	CHINA			
3	DOME CONTACT	STAINLESS STEEL	Ag clad	CHANGSUNG	KOREA			
4	STEM	PPA		SOLVAY	U.S.A	UL 94V-0	E95746	BLACK
5	COVER	STAINLESS STEEL		SAMSUNG	KOREA			
6	TAPE	PI FILM		JIABANG	CHINA			
7								
8								
9								
10								
11								
12								
13								
14								
15								
16								

## X-ON Electronics

Largest Supplier of Electrical and Electronic Components

*Click to view similar products for [Tactile Switches](#) category:*

*Click to view products by [NAMAE](#) manufacturer:*

Other Similar products are found below :

[6407-250V-25273P](#) [ADTSA62NV](#) [B3F-3123](#) [1977177-8](#) [1977266-1](#) [ADTSA63NV](#) [ADTSM21NSVTR](#) [ADTSM25RVTR](#) [ADTSM32NVTR](#)  
[ADTSMW64RV](#) [1977120-6](#) [FSMRA4JHA04](#) [GS4.70F300QP](#) [KSC241J SP DELTA LFS](#) [3FTL600RAS](#) [3FTL640RAS](#) [6407-250V-25343P](#)  
[ADTSM31NVTR](#) [2-1977120-7](#) [TSJW-5.2-260-TR](#) [Y651050400P](#) [KMT011MNGJLHS](#) [70-201.0](#) [ADTSG648NV](#) [ADTSM62KSVTR](#)  
[ADTSM648NV](#) [95C06E3RAT](#) [3ATH9Q](#) [FSMRA8JHA04](#) [HARS0073](#) [Y33R411N9FPLFT](#) [Y33R51139FPLFT](#) [Y31C01402FPLFS](#)  
[PTS645SK50SMTR92](#) [ADTSM32NVB](#) [KMS233GPWTLFG](#) [Y78B64124FP](#) [Y31CJ244KFP LFS](#) [Y96D113G0FP LFS](#) [Y33A812C5FP LFT](#)  
[Y56B2D120FP LFS](#) [Y31C5144KFP LFS](#) [PTS645 DVM83-BN125-2 LFS](#) [B3W 1000G](#) [KSC621G OL LFS](#) [B3F 1002C](#) [B3F 0047H](#) [B3W](#)  
[1002C](#) [B3F 5001G](#) [B3W 1100C](#)