

Ultra-Small Package High-Precision Voltage Detector

General Description

The LN61C series is a series of high-precision voltage detectors developed using CMOS process. The detection voltage is fixed internally with an accuracy of $\pm 2.0\%$. Two output forms, Nch open-drain and CMOS output, are available. Ultra-low current consumption and miniature package lineup can meet demand from the portable device applications.

Features

- | Ultra-low current consumption 2.0 μA typ. ($V_{in}=1.5\text{V}$)
- | High-precision detection voltage $\pm 2.0\%$
- | Operating voltage range 0.7 V to 8.0 V
- | Detection voltage 1.0V to 6.0 V (0.1 V step)
- | Output form Nch open-drain output (Active Low) or CMOS output (Active Low)

Applications

- | Battery checkers
- | Power failure detectors
- | Power monitor for portable equipments such as pagers, calculators, electronic notebooks and remote controllers.
- | Constant voltage power monitor for cameras, video equipments and communication devices.
- | Power monitor for microcomputers and reset for CPUs.

Package

- | SOT-23-3L
- | SOT-343
- | SOT-89-3L
- | TO-92

Ordering Information

LN61C ____

符号	描述	符号	描述
	Output Configuration: C=CMOS N=N-ch open drain		Detect Accuracy: 2=with $\pm 2\%$
	Detect Voltage Eg: 10=1.0V 38=3.8V		Package Type: M=SOT-23-3L
	Output Delay 0=No delay		Device Orientation: R=Embossed Taped(Right) L=Embossed Taped(Left)

Pin Configurations

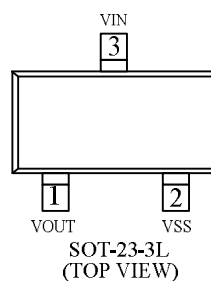

Pin Assignment

Pin No.	Pin name	Pin description
SOT-23-3L		
3	VIN	Voltage input pin
2	VSS	GND pin
1	VOUT	output pin

Typical Application Circuit

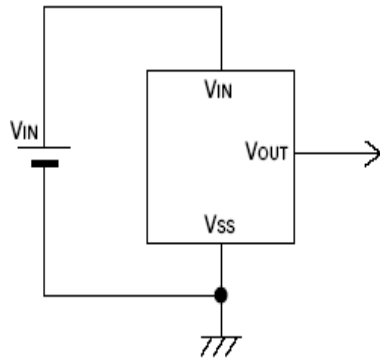

CMOS Output

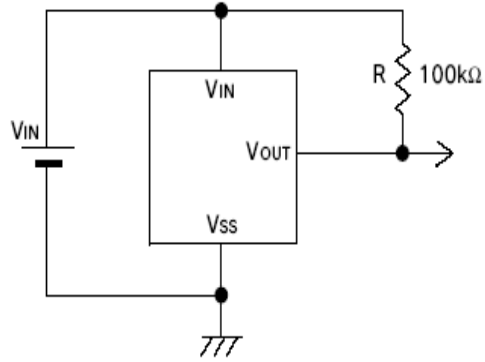

Nch Open-drain Output Test circuit

Marking Rule

I SOT-23-3L

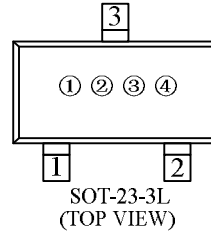

Represents the product name

Symbol	Product Description
C	LN61C

Represents the Output configuration and detect voltage range

Designator	Output Configuration	Voltage Range (V)
A	CMOS	0.1 ~ 3.0
B	CMOS	3.1 ~ 6.0
N	OPEN DRAIN	0.1 ~ 3.0
P	OPEN DRAIN	3.1 ~ 6.0

Represents the detect voltage

Designator	Detect Voltage (V)	
0	-	3.1
1	-	3.2
2	-	3.3
3	-	3.4
4	-	3.5
5	-	3.6
6	-	3.7
7	-	3.8
8	0.9	3.9
9	1.0	4
A	1.1	4.1
B	1.2	4.2
C	1.3	4.3
D	1.4	4.4
E	1.5	4.5

Designator	Detect Voltage (V)	
F	1.6	4.6
H	1.7	4.7
K	1.8	4.8
L	1.9	4.9
M	2	5
N	2.1	
P	2.2	
R	2.3	
S	2.4	
T	2.5	
U	2.6	
V	2.7	
X	2.8	
Y	2.9	
Z	3	

Based on internal standards

0 ~ 9 , A ~ Z repeated G , I , J , O , Q , W are excepted)

Function Block Diagram

(1) CMOS Output Products

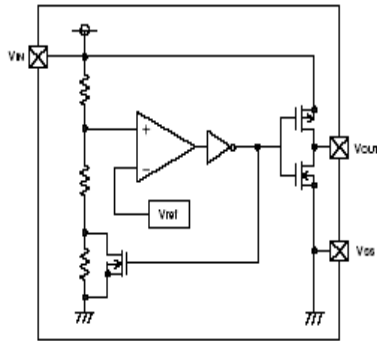

(2) Nch Open-drain Output Products

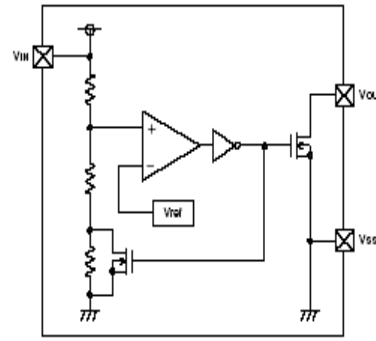

Absolute Maximum Ratings (Ta=25)

Item	Symbol	Absolute maximum ratings	unit	
Power supply voltage	Vin	8	V	
Output current	Iout	50	mA	
Output voltage	CMOS	Vss-0.3 ~ Vin+0.3	V	
	N-ch	Vss-0.3 ~ 8		
Power dissipation	SOT-23-3L	Pd	150	mW
Operating ambient temperature	Topr	-40 ~ +85		

Electrical Characteristics

(VDF (T) = 1.0 to 6.0V ±2% Ta=25)

Item	Symbol	Condition	Min.	Typ.	Max.	Unit	Test Circuit
Detection voltage	VDF		VDF x0.98	VDF	VDF x1.02	V	1
Release voltage	VHYS			VDF x0.05		V	1
Current consumption	Iss	Vin=1.0V		2.0	2.2	μA	2
		=1.5V		2.0	2.4		
		=2.0V		2.0	2.8		
		=3.0V		2.0	3.1		
		=4.0V		2.0	3.3		
		=5.0V		2.0	3.7		
					2.0		
Operating voltage	Vin	VDF=1.0 ~ 6.0V	0.7		8	V	1
Output current	Iout	Nch Vds=0.5V	Vin=1.0V	1.0	2.2	mA	3
			Vin=1.5V	2.0	5.7		
			Vin=2.0V	3.0	7.7		
			Vin=3.0V	5.0	10.1		
			Vin=4.0V	6.0	11.5		
		Vin=5.0V	7.0	13.0			
		Pch vds=2.1 vin=8.0		-10	-2		4
Temperature coefficient		-40 ~ +85		±100		ppm/	

Test Circuit

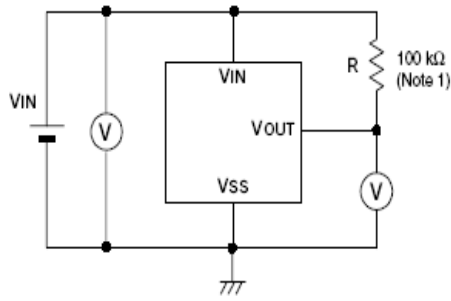

circuit 1

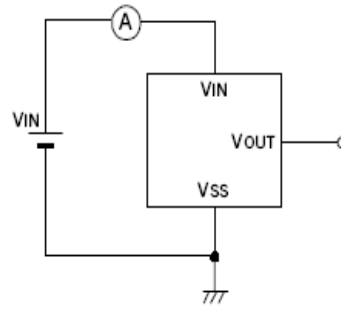

circuit 2

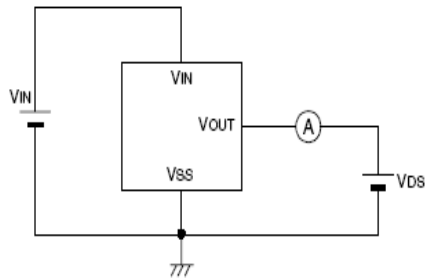

circuit 3

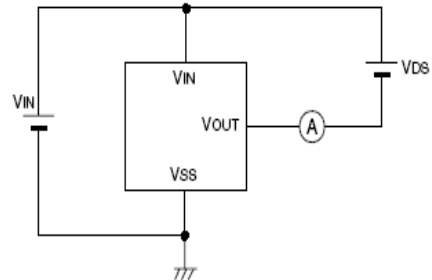

circuit4

Timing Chart

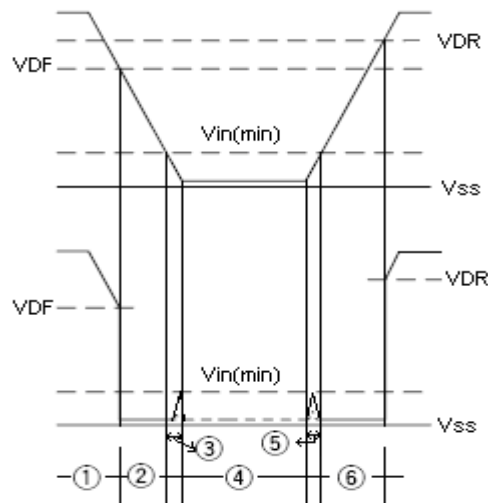

Operation

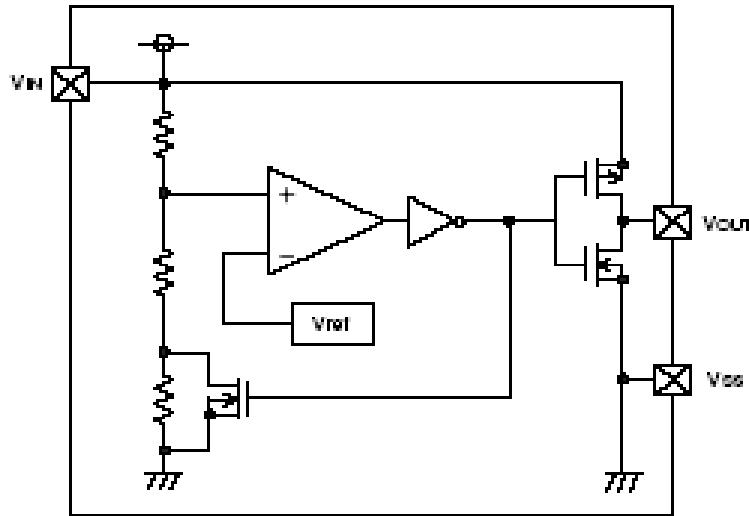

- 1-1. When the power supply voltage (VDD) is higher than the release voltage (VDF), the Nch transistor is OFF and the Pch transistor is ON to provide VDD (high) at the output.
- 1-2. When the power supply voltage (VDD) is lower than the release voltage (VDF), the Nch transistor is ON and the Pch transistor is OFF to provide VSS (low) at the output.
- 1-3. When the VDD falls below the minimum operating voltage, the output becomes undefined, or goes to the VDD when the output is pulled up to the VDD.
- 1-4. The VSS level appears when the VDD is VSS level.
- 1-5. The VSS level appears when the VDD rises above the minimum operating voltage. The VSS level still appears even when the VDD surpasses - VDF, as long as it does not exceed the release voltage + VDF.
- 1-6. When the VDD rises above + VDF the Nch transistor becomes OFF and the Pch transistor becomes ON to provide VDD level at the output.

Application Circuit Examples

I Microcomputer Reset Circuits

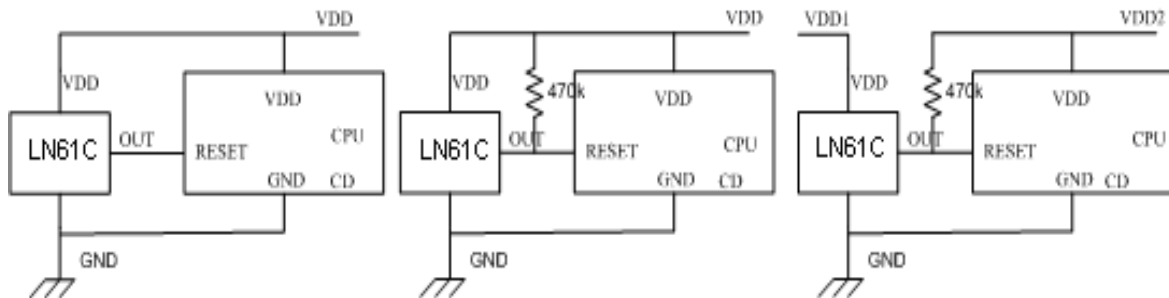

The Same supply voltage with CPU
(CMOS output)

The same supply voltage with CPU
(Nch Open drain output)

The different supply voltage with CPU
(Nch Open drain output)

I Power-on Reset Circuit

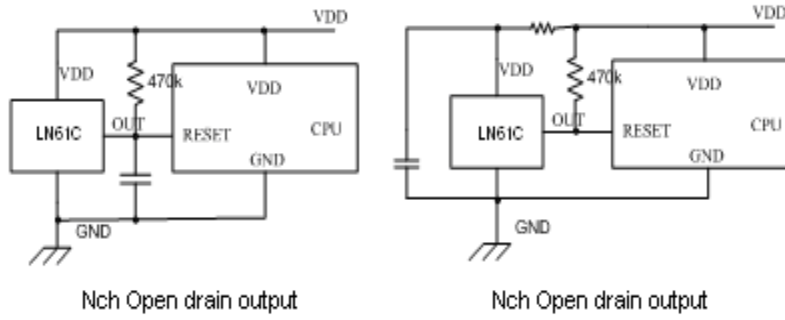

I Memory back-up circuit

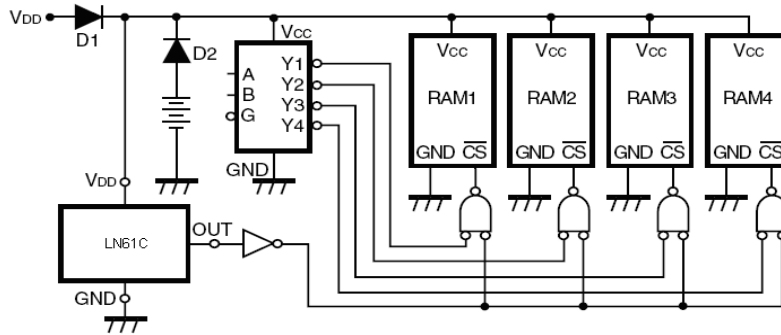

I Power failure detectors

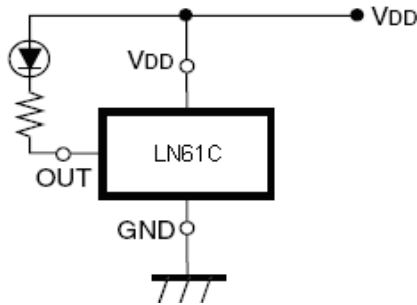

I Window Comparator Circuit

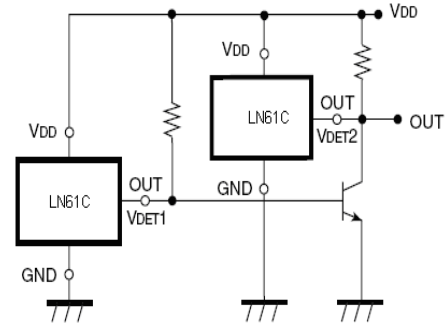

I Overcharge protect circuit

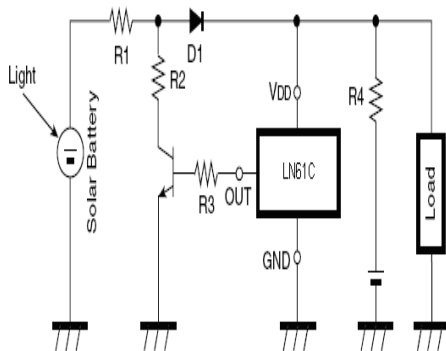

I Detector Adjustable Circuit

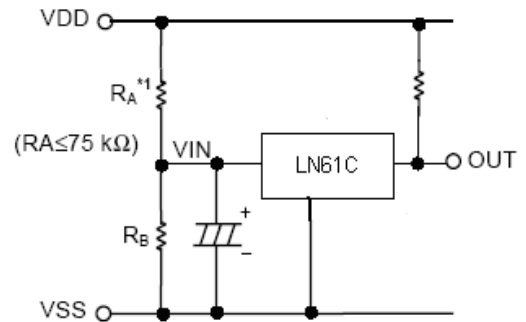

Package

I SOT-23-3L

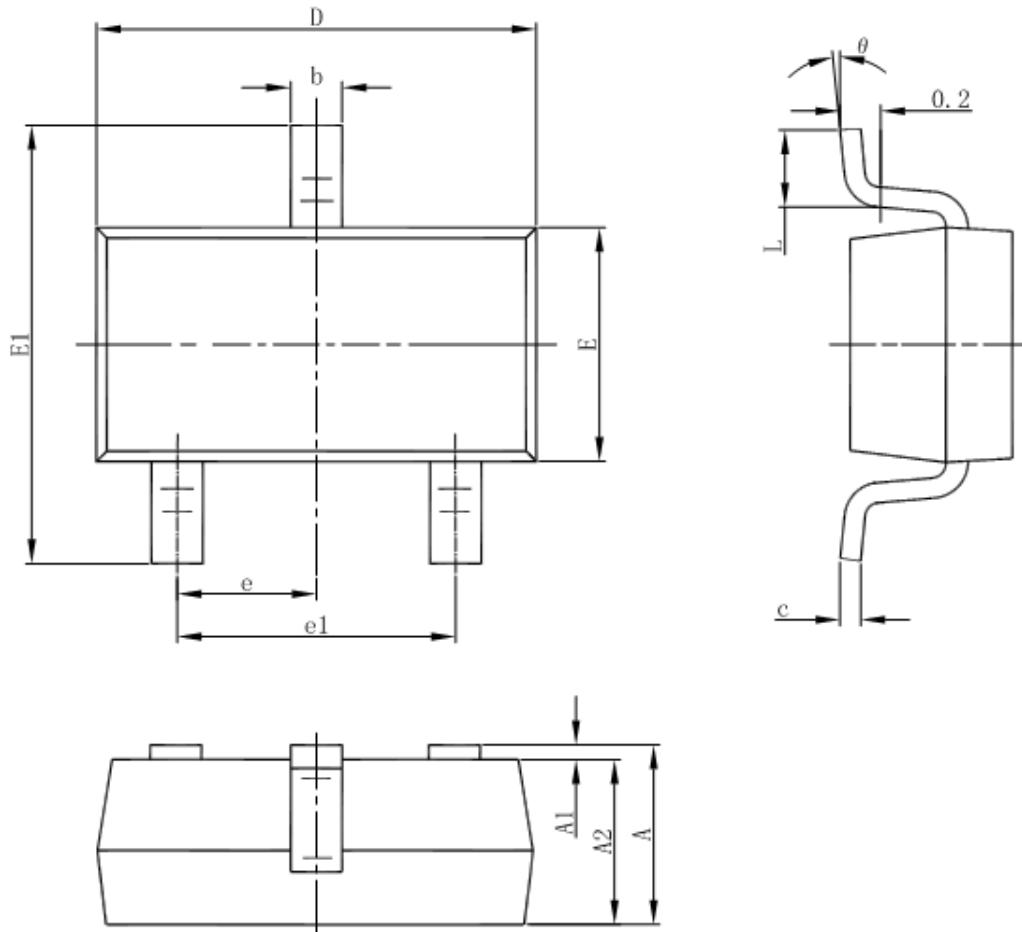

Symbol	Dimensions In Millimeters		Dimensions In Inches	
	Min	Max	Min	Max
A	1.050	1.250	0.041	0.049
A1	0.000	0.100	0.000	0.004
A2	1.050	1.150	0.041	0.045
b	0.300	0.500	0.012	0.020
c	0.100	0.200	0.004	0.008
D	2.820	3.020	0.111	0.119
E	1.500	1.700	0.059	0.067
E1	2.650	2.950	0.104	0.116
e	0.950(BSC)		0.037(BSC)	
e1	1.800	2.000	0.071	0.079
L	0.300	0.600	0.012	0.024
theta	0°	8°	0°	8°

X-ON Electronics

Largest Supplier of Electrical and Electronic Components

Click to view similar products for [Microprocessors - MPU category](#):

Click to view products by [NATLINEAR manufacturer](#):

Other Similar products are found below :

[MCIMX6D5EYM12AD](#) [A2C00010998 A](#) [ALXD800EEXJCVD C3](#) [LS1020ASE7KQB](#) [LS1020AXE7KQB](#) [A2C00010729 A](#)
[T1022NSE7MQB](#) [T1024NXE7PQA](#) [T1042NSN7WQB](#) [MPC8313EVRADDC](#) [BOXSTCK1A8LFCL](#) [LS1021ASE7KQB](#) [LS1021ASN7KQB](#)
[T1024NXN7MQA](#) [T2080NXE8MQB](#) [T2080NXN8PTB](#) [MCIMX6L3EVN10AB](#) [T2080NXE8PTB](#) [T1024NXE7MQA](#) [CM8063501521600S](#)
[R19L](#) [LS1043AXE7MQB](#) [T1024NXN7PQA](#) [LS1043ASE7QQB](#) [LS1012AXE7HKA](#) [T4240NSN7PQB](#) [MVF30NN152CKU26](#)
[FH8067303534005S](#) [R3ZM](#) [R9A07G044L24GBG#AC0](#) [SVF311R3K2CKU2](#) [HW8076502640002S](#) [R38F](#) [R7S721030VLFP#AA0](#)
[M0516LBN](#) [MCF5208CVM166](#) [MCIMX6S6AVM08AC](#) [MCIMX6U5DVM10AC](#) [TEN54LSDV23GME](#) [MC68302AG33C](#) [MC68302EH16C](#)
[MCF5233CVM150](#) [MCIMX6D6AVT10AD](#) [MCIMX6G1CVM05AB](#) [MPC8314ECVRAGDA](#) [MPC8314VRAGDA](#) [MPC8315VRAGDA](#)
[MPC8541VTAPF](#) [PIC16F1828-I/SS](#) [PIC16F690T-I/SS](#) [PIC16F877-20/PQ](#) [PIC16F727-I/PT](#) [PIC16F1823-I/SL](#)