



1. Customer's Spec. No. :  
 2. NDK Spec. No. : EXS00A-CG06572  
 3. Type : NX3225GA  
 4. Electrical Specifications

	Parameters	SYM.	Electrical Spec.				Notes
			min	typ	max	Units	
1	Nominal frequency	$f_{nom}$	12.000			MHz	
2	Overtone order	-	Fundamental			-	AT-CUT
3	Frequency tolerance	-	-15	-	+15	$\times 10^{-6}$	at +25°C
4	Frequency versus temperature characteristics	-	-30	-	+30	$\times 10^{-6}$	at -40~+85°C The reference temperature shall be +25°C
5	Equivalent Series resistance	-	-	-	100	$\Omega$	IEC $\pi$ -Network
6	Load capacitance	$C_L$	-	12	-	pF	IEC $\pi$ -Network
7	Level of drive	-	-	10	200	$\mu$ W	
8	Insulation resistance	-	500	-	-	M $\Omega$	When terminal to terminal at DC100V $\pm$ 15V.
9	Operating temperature range	$T_{opr}$	-40	-	+85	°C	
10	Storage temperature range	$T_{str}$	-40	-	+85	°C	
11	Air-tightness	-	-	-	$3.0 \times 10^{-9}$	Pa m <sup>3</sup> /s	Helium leak detector

## 5. Examination results document

Since a performance is guaranteed, an examination results document does not submit.

## 6. Application drawing

- 6.1 External dimension : EXD14B-00388  
 6.2 Taping and reel figure : EXK17B-00247  
 6.3 Holder marking : EXH11B-00027  
 6.4 Reliability assurance Item : EXS30B-00020  
 6.5 Recommendation reflow profile : EXS30B-00344

## 7. Notice

- 7.1. Order items are manufactured according to specification. As to conditions, which are not indicated in this specification and unpredictable such as applied condition and oscillation margin, please check them beforehand.
- 7.2. Crystal units will be damaged by ultrasonic welding process due to resonance of crystal wafer itself. NDK does not recommend using ultrasonic welding. If Ultra Sonic welding used, NDK strongly recommend verifying crystal unit damage by ultrasonic weld.
- 7.3. Unless we receive request for modification within 3 weeks from the issue date of this NDK specification sheet, we will supply products according to this specification. Also, if you'd like to modify specification of order, which has been placed with delivery request within 3 weeks from the issue data of this specification sheet, we would like to discuss with you separately.
- 7.4. In no event shall the company be liable for any product failure resulting from an inappropriate handling or operation of the product beyond the scope of its guarantee.
- 7.5. Where any change to the process condition is made due to the change(s) in the production line, inform personnel of the specifications.
- 7.6. Should this specification data give rise to any disputes relating to any intellectual property rights or any other rights of a third person, the company shall not indemnify anyone for any damage. Their disclosure must not be construed as the grant of a license to use any of the intellectual property rights owned by the company.
- 7.7. If you intend to use products listed on this specification for applications that may result in loss of life or assets (controls relating to safety, medical equipment, aeronautical equipment, space equipment, etc.), please do not fail to advise us of your intention beforehand.
- 7.8. In the company's production process whatever amount of ozone depleting substances (ODS) as specified in the Montreal protocol is not used.
- 7.9. Information contained in this specification must not be quoted, reproduced or used for other purposes including processing either in part or in full without obtaining prior approval from the company.
- 7.10 The appearance color has a different case by purchasing it more than 2 suppliers of the component, but characteristic and reliability are guaranteed.
- 7.11 In case of the product long time keep at high temperature and humidity, may affect product characteristic (solder ability) and a packing condition.  
Please keep at storage condition of temperature +5°C ~+35°C, humidity ~85%RH.

## 8. Prohibited items

Be sure to use the product under the following conditions. Otherwise, the characteristics deterioration or destruction of the product may result.

### (1) Reflow soldering heat resistance

- Peak temperature: 265°C, 10 sec
- Heating: 230°C or higher, 40 sec
- Preheating: 150°C to 180°C, 120 sec
- Reflow passage times: twice

### (2) Manual soldering heat resistance

- Pressing a soldering iron of 400°C on the terminal electrode for four seconds (twice).
- When using a soldering iron, press its tip on the part below the sealed part, avoiding the glass-sealed part (otherwise, the glass will melt and air-tightness may be lost).

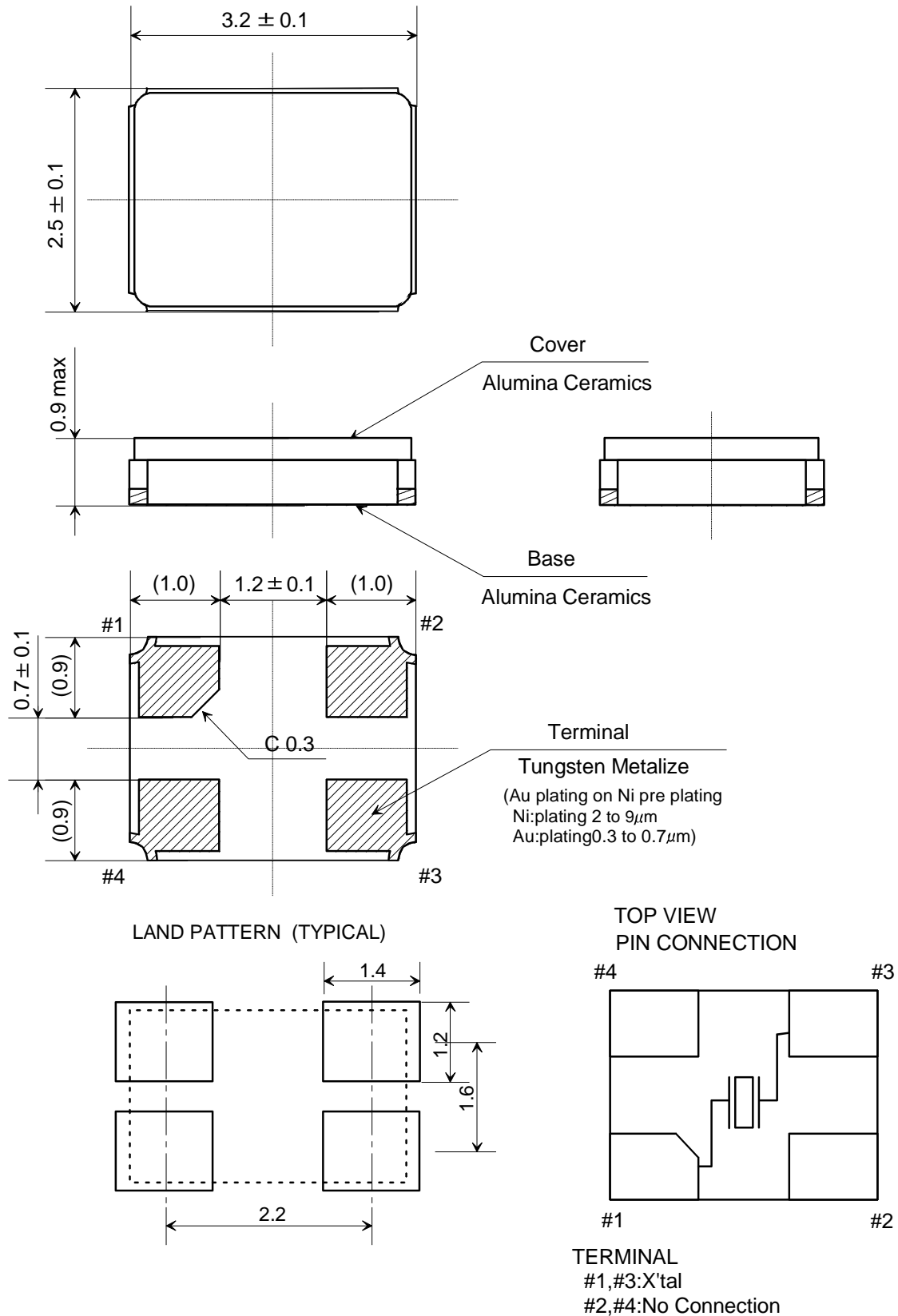

Date of Revise		Charge	Approved	Reason	
A					
Drawn	Date	Name	Third Angle Projection	Tolerance	Scale
30.Jun.2006	H.Yagishita	Dimension:mm	---	- / -	
Designed	Date	Name	Title	Drawing No.	Rev.
30.Jun.2006	H.Yagishita				
30.Jun.2006	K.Kubota				
30.Jun.2006	T.Ishii		<b>NX3225GA</b> <b>Dimension Drawing</b>	<b>EXD14B-00388</b>	

**NIHON DEMPA KOGYO CO., LTD.**

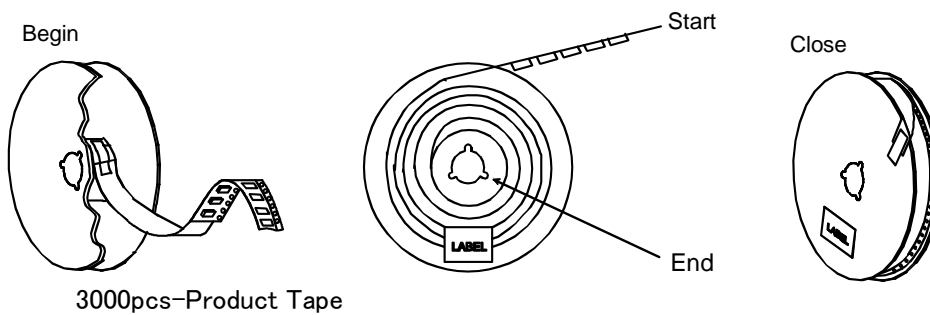
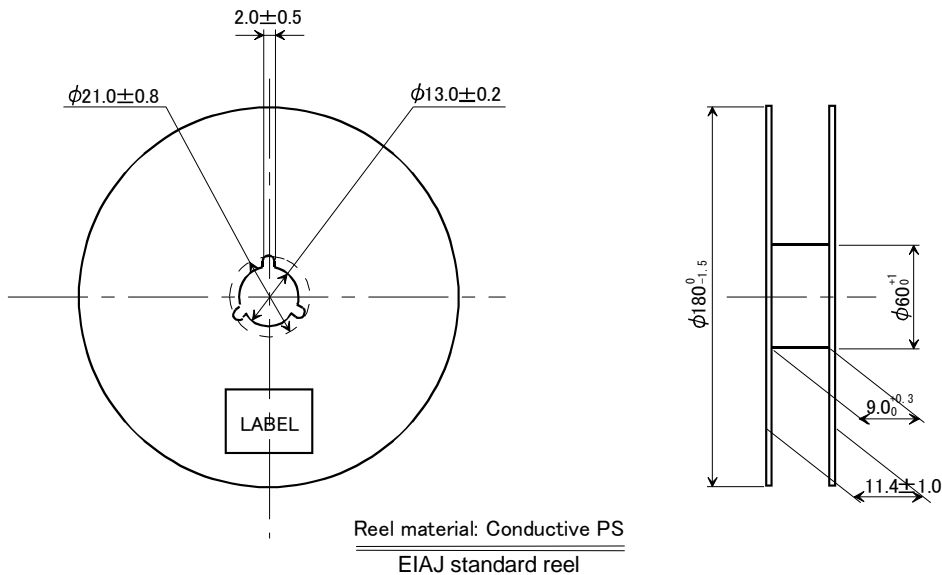
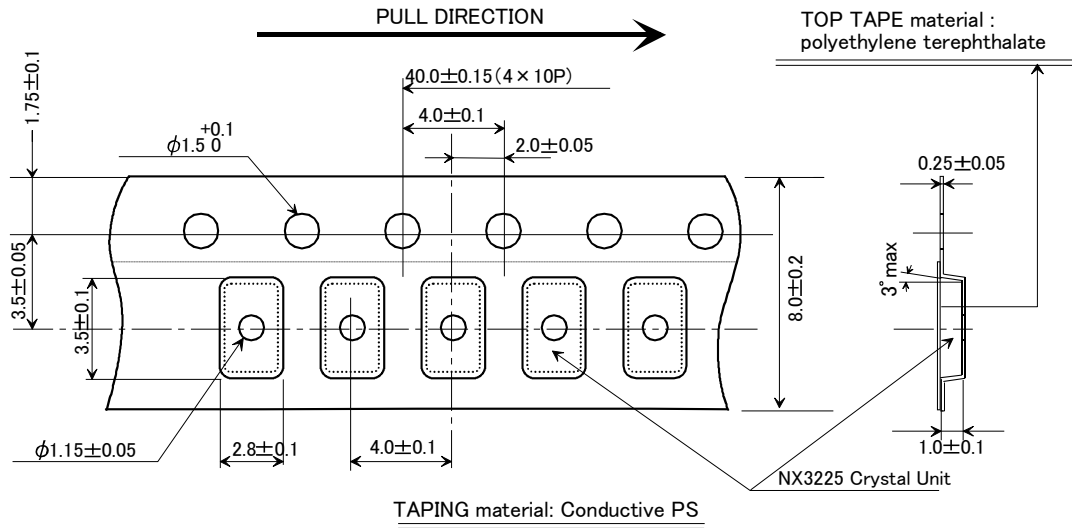

	Date of Revise	Charge	Approved	Reason		
A	26 Mar. 2013	T. Shimizu	K. Oguri	The appearance of a drawing was corrected.		
Drawn	Date	Name	Third Angle Projection	Tolerance		
30.Jun.2006	H.Yagishita	Dimension:mm	---	Scale		
Designed	30.Jun.2006	H.Yagishita	Title	Drawing No.		
Checked	30.Jun.2006	K.Kubota			EXK17B-00247	Rev.
Approved	30.Jun.2006	T.Ishii				B
			<b>NX3225 Series Taping and Reel Spec.</b>			

**NIHON DEMPA KOGYO CO., LTD.**

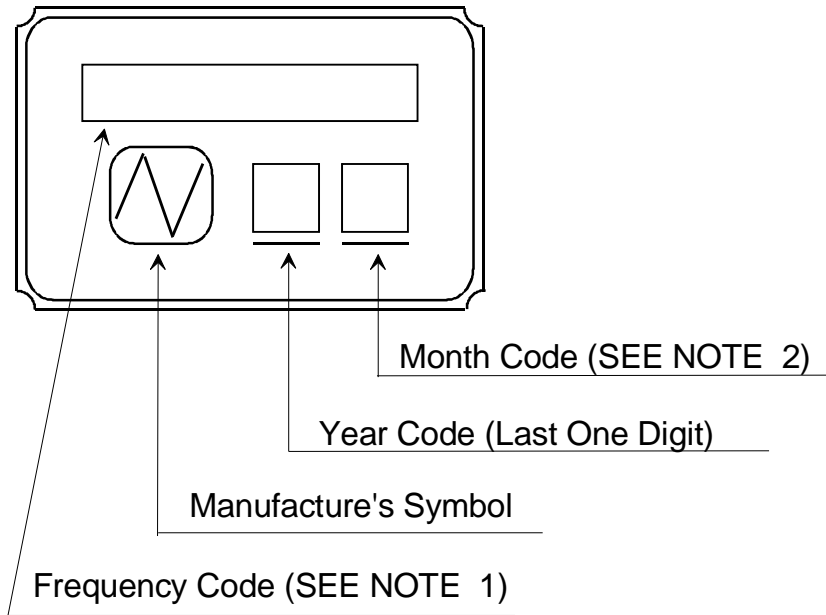

NOTE

1. Frequency Code

Marking Frequency is consist of five digits, first five digits of Nominal Frequency

Example

Nominal Frequency	28.636363 MHz
Frequency Code	28.636

2. Month Code Table

Month	1 Jan.	2 Feb.	3 Mar.	4 Apr.	5 May.	6 Jun.	7 Jul.	8 Aug.	9 Sep.	10 Oct.	11 Nov.	12 Dec.
Month Code	1	2	3	4	5	6	7	8	9	X	Y	Z

\*Marking digits are not include a decimal point and dot mark.

	Date of Revise	Charge	Approved	Reason			
B	9.Nov.2000	H.Yagishita	T.Ishii	Change Form			
	Date	Name	Third Angle Projection	Tolerance		Scale	
Drawn	3.Aug.1999	Y.Morizumi	Dimension:mm			/	
Designed	3.Aug.1999	Y.Morizumi	Title <b>Crystal Holder Marking</b>		Drawing No. <b>EXH11B-00027</b>		Rev.
Checked	-----	-----					B
Approved	3.Aug.1999	T.Ishii					

**NIHON DEMPA KOGYO CO., LTD.**

**Reliability assurance item**

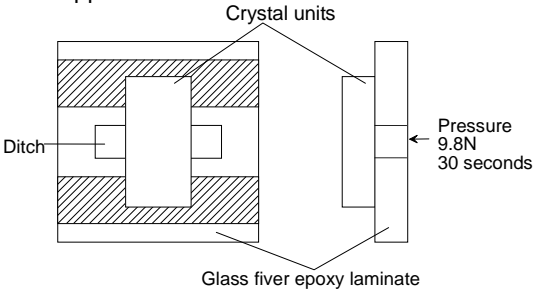
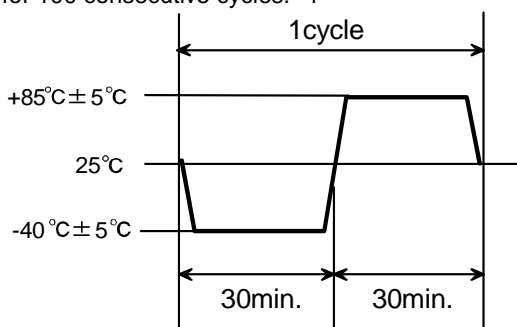
No.	Test Item	Test Methods	Specification Code
1	Drop	Devices are dropped from the height 75cm onto wooden block. ( more than 30mm thickness. ) Execution 3 times random drops.	A
2	Shock	Devices are shocked to half sine wave (981m/s <sup>2</sup> ) three mutually perpendicular axis each 3 times.	A
3	Vibration	Frequency Range : 10 to 55 Hz Amplitude : 1.5mm Sweep time : 1 min. Test time : 2.0 hours	A
4	Electrode adherent strength	Reflow soldering shall be used for soldering on test fixture (Glass fiber epoxy laminate : Thickness 1.6mm+/-0.2mm) shown below. (220~240°C) Be careful to happen the heat shock. 	B
5	Solderability	Pre-heat temperature : 150°C Pre-heat Time : 60~120sec. Peek temperature : 240±5°C Soldering temperature : Over 215°C Test time : 10~30 sec.	C
6	Resistance to soldering heat	Pre-heat temperature : 150 °C Pre-heat time : 60 ~ 120sec. Test temperature : 260 ± 5 °C Test time : 10 sec. Max.	A, B
7	Resistance to cold	Leave at -40°C ± 2 °C for 500 hours.	A
8	Resistance to heat	Leave at +85°C ± 2 °C for 500 hours. *1	A
9	Humidity	Devices are left in temperature at +60°C with relative humidity of 90~95% for 500 hours.	A, D
10	Thermal shock	Devices are left into the following temperature cycle as shown in (Figure 1) for 100 consecutive cycles. *1 	A, B

**\*1. Resistance to heat and Thermal shock**

In case of spec on High temperature exceed +85°C, above test according to spec high temperature will be perform and guarantee.

Specification code	Specification
A	Frequency tolerance and series resistance should be cleared.
B	After testing unless cracking of materials view of eyes and unless break of seal.
C	The leads shall acquire a new solder coat cover at 90% of immersed area.
D	Insulation resistance shall be greater than 500MΩ

## Recommendation reflow condition

### 1.IR reflow condition

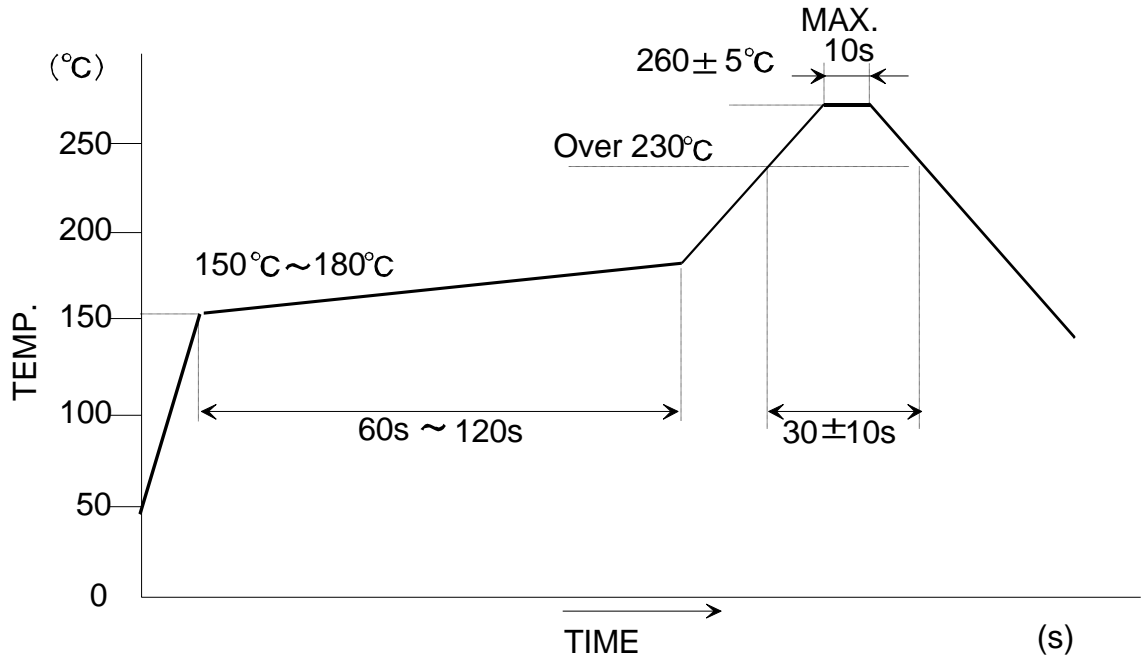



## X-ON Electronics

Largest Supplier of Electrical and Electronic Components

*Click to view similar products for [Crystals](#) category:*

*Click to view products by [NDK](#) manufacturer:*

Other Similar products are found below :

[CX3225GB25000M0PPSZ1](#) [718-13.2-1](#) [7A-40.000MAAE-T](#) [FL2000085](#) [99-BU](#) [9B-15.360MBBK-B](#) [9C-7.680MBBK-T](#) [H10S-12.000-18-EXT-TR](#) [ABC2-6.000MHZ-D4Z-T](#) [ABLS-20.000MHZ-D2-T](#) [ABS071-32.768KHZ-6-T](#) [R38-32.768-12.5-5PPM-NPB](#) [BTD1062E05A-513](#) [21U15A-21.4MHZ](#) [RTX-781DF1-S-20.950](#) [LFXTAL066198Cutt](#) [9C-14.31818MBBK-T](#) [A-11.000MHZ-27](#) [ABL-27.000MHZ-B4Y-T](#) [ABM11-132-24.000MHZ-T3](#) [ABM3B1-25.000MHZ-D2Y-T](#) [SPT2A-.032768B](#) [SPT2A.032768G](#) [LFXTAL065253Cutt](#) [LFXTAL066431Cutt](#) [XT9S20ANA14M7456](#) [XT9SNLANA16M](#) [7A-24.576MBBK-T](#) [7B-30.000MBBK-T](#) [CX2520DB16000H0HPQCC](#) [MMCC2R32.7680KHZ](#) [6504-202-1501](#) [6526-202-1501](#) [ABLS-12.000MHZ-B2Y-T](#) [7A-10.000MBBK-T](#) [SG636PCE-20.000MC](#) [3404](#) [CM315D32768EZFT](#) [C1E-24.000-7-2020-R](#) [C1E-19.200-12-1530-X-R](#) [C1E-16.000-12-1530-X-R](#) [ABM11-16.000MHZ-9-B1U-T](#) [FL5000014](#) [EUCA18-3.1872M](#) [FX0800015](#) [425F35E027M0000](#) [FP0800018](#) [MS3V-T1R-32.768kHz-7pF-20PPM-TA-QC-Au](#) [VXM7-1C1-16M000](#) [MS3V-T1R-32.768kHz-9pF-20PPM-TA-QC-Au](#)