



REFERENCE SPECIFICATION

Customer: _____

Item: Crystal Unit

Type: NX5032GA

Nominal Frequency: 8.000 MHz

Customer's Spec. No.: _____

NDK Spec. No.: EXS00A-CG03974

For your reference we submit this specification.
Please study and keep in your related document file.

Charge:

Sales		
Engineer		

Approved	<u>H.Kobayashi</u>
Checked	<u>---</u>
Drawn	<u>K.Nakashima</u>

Revision Record				
Rev.	Rev. Date	Items	Contents	Remarks
----	29. Oct. 2013	Issue		

- 1.Customer specifications number :
- 2.NDK specification number : EXS00A-CG03974
- 3.Type : NX5032GA
- 4.Electrical characteristics
- 4.1 Nominal frequency : 8.000 MHz
- 4.2 Overtone order : Fundamental
- 4.3 Frequency tolerance : $\pm 20 \times 10^{-6}$ max. (+25 °C)
- 4.4 Frequency versus temperature characteristics : $\pm 50 \times 10^{-6}$ max. (-40~+85 °C)
The reference temperature shall be 25°C
- 4.5 Equivalent resistance : 300Ω max.
- 4.6 Maximum level of drive : 500μW max.
- 4.7 Insulation resistance : Terminal to terminal insulation resistance also terminal to cover insulation resistance must be 500MΩ (min) when DC100V ±15V is applied.
5. Measurement circuit
- 5.1 Frequency measurement
- *Measuring instrument : π-Network
- * Load capacitance(C_L) : 8pF
- *Level of drive : 50μW
- 5.2 Equivalent resistance measurement
- * Measuring instrument : π-Network
- * Load capacitance(C_L) : Series
- *Level of drive : 50μW
6. Other performances
- 6.1 Storage temperature range : -40~+85°C
- 6.2 Air-tightness : Less than 3×10^{-9} Pa m³/s (Helium leak detector)
7. Examination results document
Since a performance is guaranteed, an examination results document does not submit.
8. Application drawing
- 8.1 External dimension : EXD14B-00016
- 8.2 Taping and reel figure : EXK17B-00027
- 8.3 Holder marking : EXH11B-00027
- 8.4 Reliability assurance Item : EXS30B-00020
- 8.5 Recommendation reflow profile : EXS30B-00344

9. Notice

Order items are manufactured according to specification. As to conditions, which are not indicated in the specification and unpredictable such as applied condition and oscillation margin, please check them beforehand.

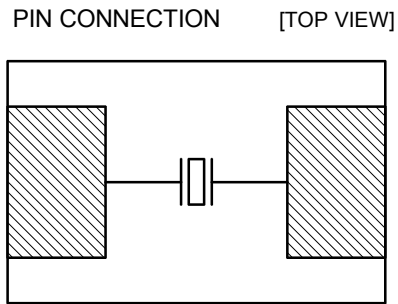
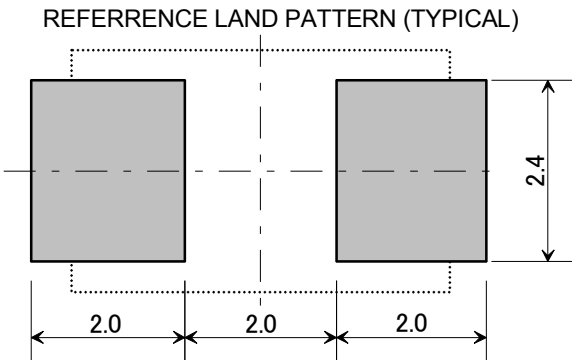
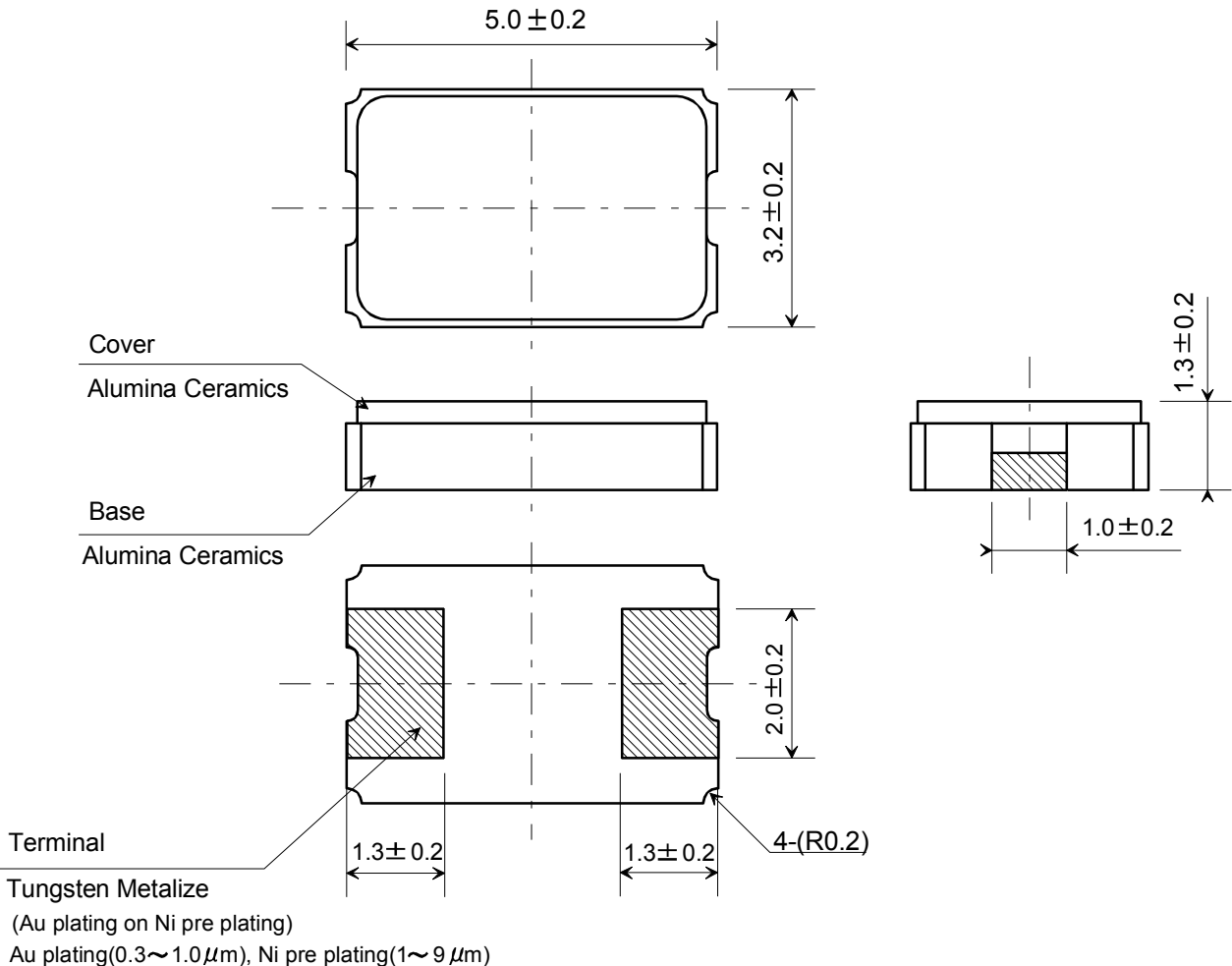

	Date of Revise	Charge	Approved	Reason	
E	15.Sep.2006	N.Yamamoto	K.Kubota	Change reference land pattern size	
	Date	Name	Third Angle Projection	Tolerance	
Drawn	19.Mar.1999	Y.Morizumi	Dimension:mm	Scale	
Designed	19.Mar.1999	Y.Morizumi	Title NX5032GA External Dimension	Drawing No. EXD14B-00016	
Checked	19.Mar.1999	M.Miura			Rev.
Approved	19.Mar.1999	M.Okamoto			E

NIHON DEMPA KOGYO CO., LTD.

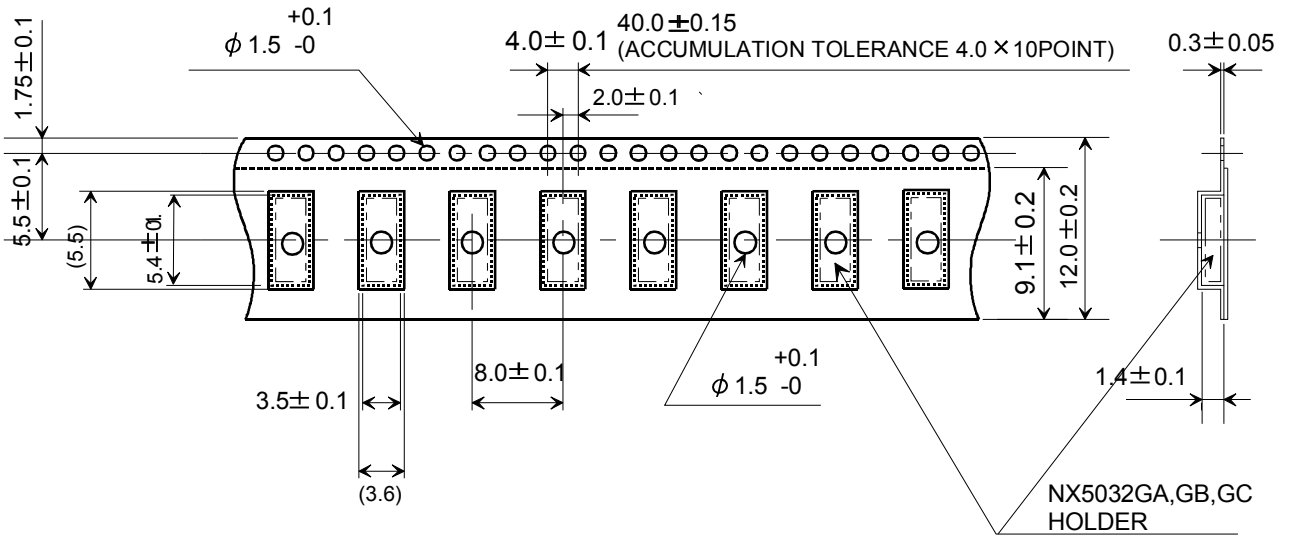

TAPING

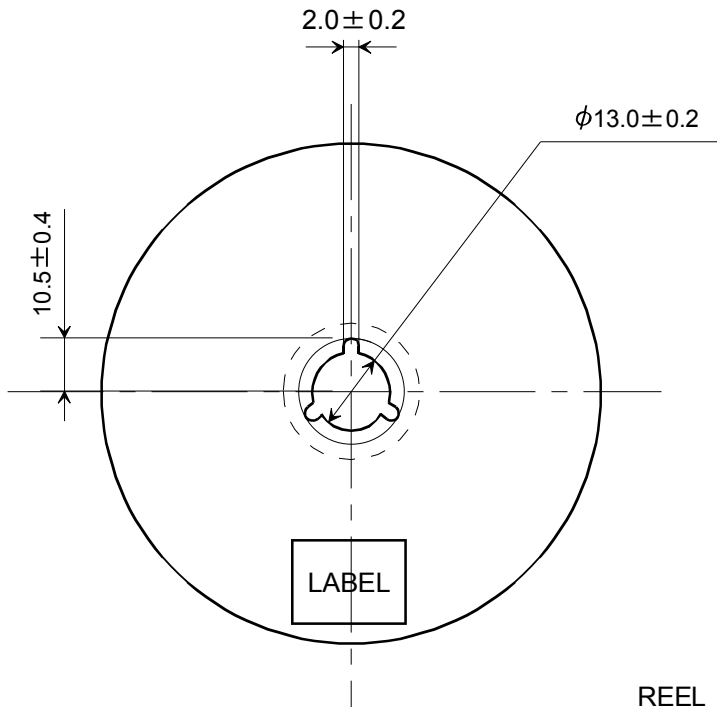

REEL

QTY.
1000 PCS

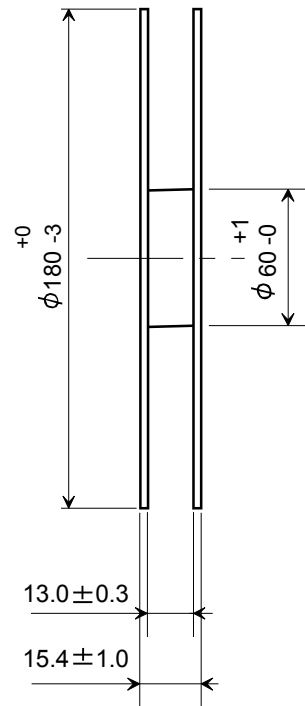

	Date of Revise	Charge	Approved	Reason
C	19.Dec.2008	K.Oguri	K.Miyashita	Addition of NX5032GB, GC
	Date	Name	Third Angle Projection	Tolerance
Drawn	13.Jul.1999	Y.Morizumi	Dimension:mm	Scale
Designed	13.Jul.1999	Y.Morizumi	Title	Drawing No.
Checked	-----	-----	Crystal Holder Packing	EXK17B-00027
Approved	13.Jul.1999	M.Okamoto		
				C

NIHON DEMPA KOGYO CO., LTD.

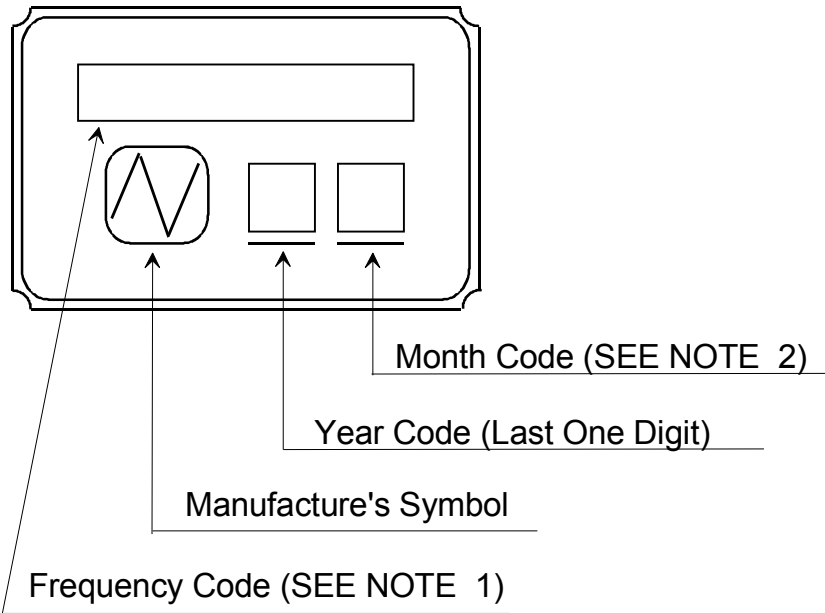

NOTE

1. Frequency Code

Marking Frequency is consist of five digits, first five digits of Nominal Frequency

Example

Nominal Frequency	28.636363 MHz
Frequency Code	28.636

2. Month Code Table

Month	1 Jan.	2 Feb.	3 Mar.	4 Apr.	5 May.	6 Jun.	7 Jul.	8 Aug.	9 Sep.	10 Oct.	11 Nov.	12 Dec.
Month Code	1	2	3	4	5	6	7	8	9	X	Y	Z

*Marking digits are not include a decimal point and dot mark.

	Date of Revise	Charge	Approved	Reason			
B	9.Nov.2000	H.Yagishita	T.Ishii	Change Form			
	Date	Name	Third Angle Projection	Tolerance		Scale	
Drawn	3.Aug.1999	Y.Morizumi	Dimension:mm			/	
Designed	3.Aug.1999	Y.Morizumi	Title		Drawing No.		Rev.
Checked	-----	-----	Crystal Holder Marking		EXH11B-00027		B
Approved	3.Aug.1999	T.Ishii					

NIHON DEMPA KOGYO CO., LTD.

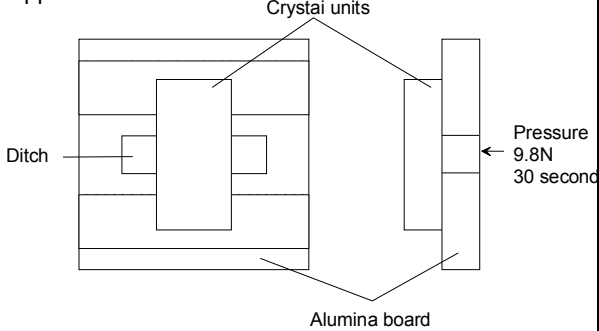
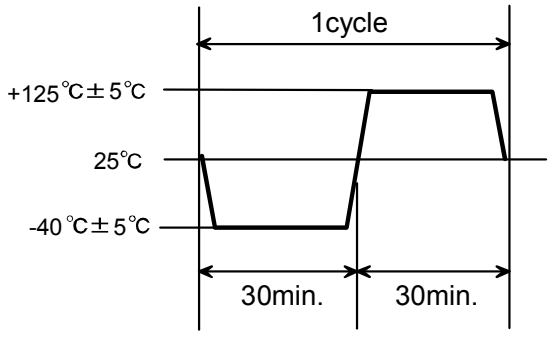
No.	Test item	Test methods	Spec. code
1	Drop	Devices are dropped from the height 75cm onto concrete. Execution 3 times random drops.	A
2	Shock	Acceleration: 50000m/s ² (5000G) Duration:0.15 msec Half-Sine pulse 1 Shocks in 6 mutually perpendicular planes, Total 6 shocks	A
3	Vibration	Frequency range: 10 to 2000 Hz Amplitude or acceleration : 1.52 mm or 200 m/s ² (20G) Sweep time: 20 minutes Test time: 4 hours × 3	A
4	Electrode adherent strength	Reflow soldering shall be used for soldering on test fixture (Glass fiber epoxy laminate : Thickness 1.6mm+/-0.2mm) shown below. (220~240°C) Be careful to happen the heat shock. 	B
5	Solderability	Pre-heat temperature : 150°C Pre-heat Time : 60~120sec. Peek temperature : 240±5°C Solderind temperature : Over 215°C Test time : 10~30 sec.	C
6	Resistance to soldering heat	Pre-heat temperature : 150°C Pre-heat Time : 60~120sec. Test temperature : 260±5°C Test time : 10 sec. Max.	A,B
7	Resistance to cold	Leave at -40 °C ± 2 °C for 1000 hours.	A
8	Resistance to heat	Leave at +125 °C ± 2 °C for 1000 hours.	A
9	Humidity	Device are left in temperature at +85 °C with relative humidity of 80~85% for 1000 hours.	A,D
10	Thermal shock	Device are left into the following temperature cycle as shown in (Figure1) for 500 consecutive cycle. 	A,B

Spec. code	Specification
A	Frequency tolerance and series resistance should be cleared.
B	After testing unless cracking of materials view of eyes and unless break of seal.
C	The leads shall acquire a new solder coat cover at 90 % of immersed area.
D	Insulation resistance shall be greater than 500 MΩ.

Recommendation reflow condition

1.IR reflow condition

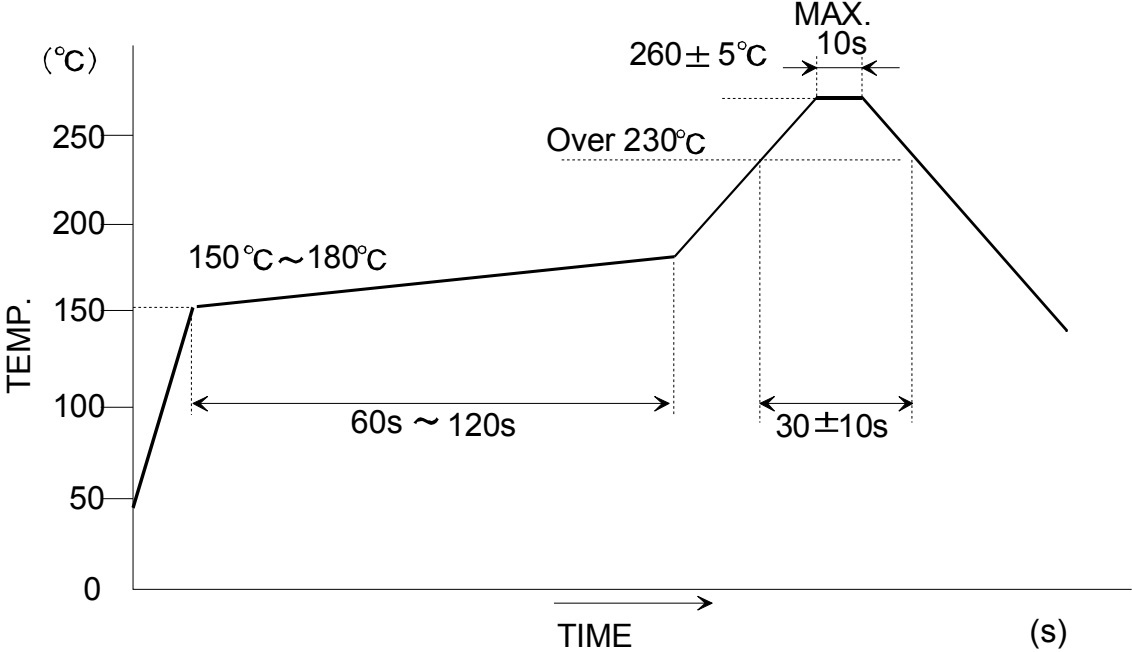

X-ON Electronics

Largest Supplier of Electrical and Electronic Components

Click to view similar products for [Crystals](#) category:

Click to view products by [NDK](#) manufacturer:

Other Similar products are found below :

[CX3225GB25000M0PPSZ1](#) [718-13.2-1](#) [MC405 32.0000K-R3:PURE SN](#) [7A-40.000MAAE-T](#) [FL2000085](#) [99-BU](#) [9B-15.360MBBK-B](#) [9C-7.680MBBK-T](#) [H10S-12.000-18-EXT-TR](#) [ABC2-6.000MHZ-D4Z-T](#) [ABLS-20.000MHZ-D2-T](#) [ABS071-32.768KHZ-6-T](#) [R38-32.768-12.5-5PPM-NPB](#) [BTD1062E05A-513](#) [21U15A-21.4MHZ](#) [RTX-781DF1-S-20.950](#) [LFXTAL066198Cutt](#) [9C-14.31818MBBK-T](#) [A-11.000MHZ-27](#) [ABL-27.000MHZ-B4Y-T](#) [ABM11-132-24.000MHZ-T3](#) [ABM3B1-25.000MHZ-D2Y-T](#) [SPT2A-.032768B](#) [SPT2A.032768G](#) [SSPT7F-9PF20-R](#) [FX325BS-38.88EEM1201](#) [LFXTAL065253Cutt](#) [LFXTAL066431Cutt](#) [XT9S20ANA14M7456](#) [XT9SNLANA16M](#) [7A-24.576MBBK-T](#) [7B-30.000MBBK-T](#) [7A-14.31818MBBK-T](#) [6504-202-1501](#) [6526-202-1501](#) [ABLS-12.000MHZ-B2Y-T](#) [7A-10.000MBBK-T](#) [SG636PCE-20.000MC](#) [3404](#) [E1SAA18-25.000M TR](#) [CM315D32768EZFT](#) [C1E-24.000-7-2020-R](#) [C1E-19.200-12-1530-X-R](#) [C1E-16.000-12-1530-X-R](#) [ABM11-16.000MHZ-9-B1U-T](#) [FL5000014](#) [EUCA18-3.1872M](#) [FX0800015](#) [425F35E027M0000](#) [FP0800018](#)