

NeoCortec-NC2400

Wireless Mesh Network Module Series

Datasheet version 1.2

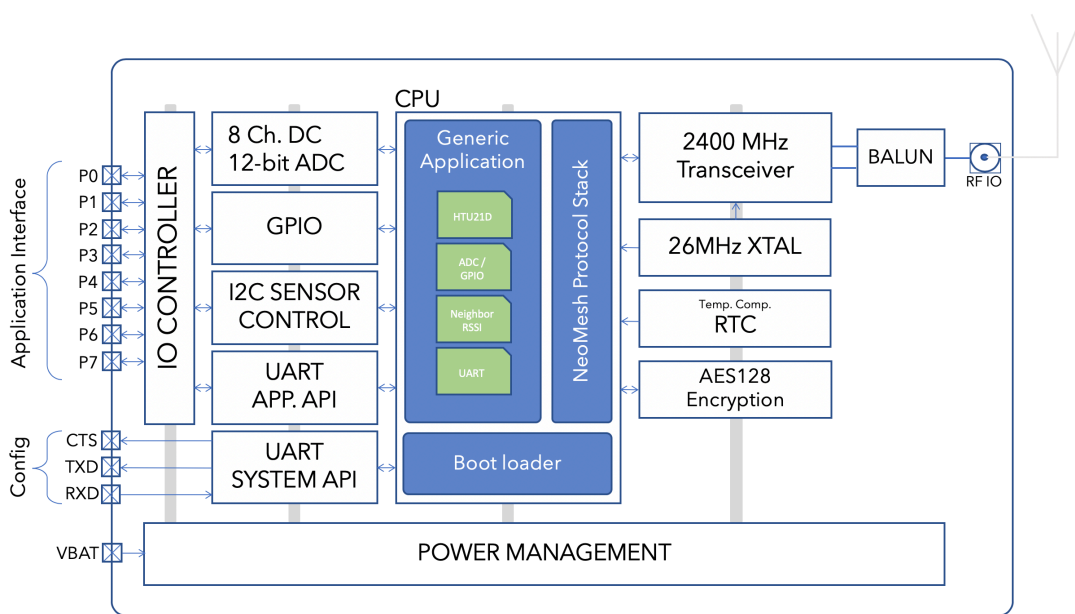
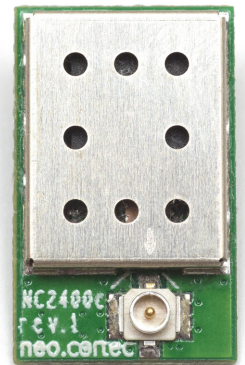

FEATURES:

- Full System in a module:
 - Add power and an antenna to create a fully functional Wireless Mesh Network node
 - NeoMesh Protocol Stack optimized for ultra low power and reliability
 - Generic Application layer which can be configured to suit the product needs
- Ultra Small Form factor which allows for easy integration in compact products
- Supply Range 2.0 - 3.6V suitable for direct battery operation
- Pre certified for ETSI, FCC & IC

APPLICATIONS:

- Wireless Sensor Networks
- Automatic Meter Reading
- Advanced Metering Infrastructure
- Mobile Ad-Hoc Networks
- Home Control & Building Automation
- Industrial Automation
- Alarm and Security Systems
- Agricultural and Forest Monitoring

1. Absolute Maximum Ratings

Under no circumstances must the absolute maximum ratings given in Table 1 be violated. Stress exceeding one or more of the limiting values may cause permanent damage to the module.

Parameter	Min	Max	Unit	Condition
Supply voltage (VDD)	-0.3	3.9	V	All supply pins must have the same voltage
Voltage on any digital pin	-0.3	VDD + 0.3, max 3.9	V	
Voltage on U.FL connector	-0.3	2.0	V	
Voltage ramp-up rate		120 kV/μs		
Input RF level		10 dBm		
Storage temperature range	-50	150	°C	
Solder reflow temperature		260	°C	According to IPC/JEDEC J-STD-020D
ESD		750	V	According to JEDEC STD 22, method A114, Human Body Model (HBM)
ESD		500	V	According to JEDEC STD 22, C101C, Charged Device Model (CDM)

Table 1: Absolute maximum ratings

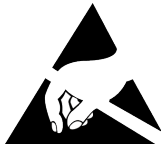

Caution! ESD sensitive device.
Precaution should be used when handling the device in order to prevent permanent damage.

2. Conditions for operational use

Parameter	Min	Max	Condition
Operational temperature	-40°C	85°C	
Supply voltage, VDD	2V	3.6V	

Table 2: Conditions for normal use.

3. Power consumption

TA = 25°C, VDD = 3.0 V if nothing else stated. Measured on NC2400C module. Please note that average current consumption is given by Protocol Settings. The expected average current consumption can be calculated using the Configuration tool provided.

Parameter	Min	Typ	Max	Unit	Condition
Receive, Rx, current		26		mA	Standard protocol
Transmit, Tx, current		27.5		mA	Standard protocol
CPU activity,		4.5		mA	Standard protocol, without radio activity
Sleep mode		0.5	2	μA	Oscillators, except 32768Hz oscillator, are off.

Table 3: Power consumption

3.1 I/O DC characteristics

TA = 25°C, VDD = 3.0 V if nothing else stated.

Digital Inputs/Outputs	Min	Typ	Max	Unit	Condition
Logic "0" input voltage			30	%	Of VDD supply (2.0 - 3.6 V)
Logic "1" input voltage	70			%	Of VDD supply (2.0 - 3.6 V)
Logic "0" input current per pin			12	nA	Input is 0V
Logic "1" input current per pin			12	nA	Input is VDD
Logic "0" input current RESET pin			65	μA	VDD = 3.6V, due to 56k2 pull-up
I/O pin pull-up and pull-down resistor		20		kΩ	

Table 4: DC characteristics

3.2 I/O AC characteristics

TA = 25°C, VDD = 3.0 V if nothing else stated.

Digital Inputs/Outputs	Min	Typ	Max	Unit	Condition
Port output rise time (min. / max. drive strength) ¹		3.15 / 1.34		ns	Load = 10 pF Timing is with respect to 10% VDD and 90% VDD levels.
Port output fall time (min. / max. drive strength) ¹		3.2 / 1.44		ns	Load = 10 pF Timing is with respect to 90% VDD and 10% VDD levels.

¹ Min. drive is for VDD ≥ 2.6V, Max drive is for VDD < 2.6V

3.3 RF parameters

Parameters	Min	Typ	Max	Unit	Condition
Receiver					
Receiver sensitivity		-82		dBm	1% packet loss
Saturation		-15		dBm	
Spurious emissions 25 MHz - 1 GHz			-57	dBm	Conducted measurement in a 50 Ω single ended load. Complies with EN 300 328, EN 300 440 class 2, FCC CFR47, Part 15 and ARIB STD-T-66.
Above 1 GHz			-47	dBm	
Transmitter					
Output power, highest setting		1		dBm	Delivered to a 50 Ω single-ended load via U.FL connector
Output power, lowest setting		-30		dBm	Delivered to a 50 Ω single-ended load via U.FL connector
Spurious emissions 25 MHz - 1 GHz			-36	dBm	0 dBm output power. Restricted band in Europe. Restricted bands in USA
47 - 74, 87.5 - 118, 174 - 230, and 470 - 862 MHz			-54	dBm	
1800 - 1900 MHz			-47	dBm	
At 2·RF and 3·RF			-41	dBm	
Otherwise above 1 GHz			-30	dBm	

Table 5: RF, receive and transmit parameters

4. Pin description

Pin number	Pin name	Pull at Reset	IO-type	Description of function
1	GND			Module ground
2	nRESET	PU-res	I	Module reset
3	SAPI_RX	PU	I	UART Rx, Transmit data, System API
4	SAPI_CTS		O	CTS, Module ready to accept commands, System data
5	SAPI_TX		O	UART Tx, Received data, System API
6	GND			Module ground
7	nWES	PU	I	Enable WES Client
8	Reserved			Leave unconnected
9	GND			Module ground
10	Reserved			Leave unconnected
11	Reserved			Leave unconnected
12	Reserved			Leave unconnected
13	nWU/P0		O/IO	nWU. Indicates activity state of module. Active low/ P0 Function
14	P1		IO	P1 Function
15	GND			Module ground
16	AAPI_RX / P2	PU/	I/IO	UART Rx, Transmit data, Application data / P2 Function
17	AAPI_TX / P3		O/IO	UART Tx, Received data, Application data / P3 Function
18	P4		IO	P4 Function
19	AAPI_CTS / P5		O/IO	CTS, Module ready to accept commands, Application data / P5 Function
20	P6			P6 Function
21	P7			P7 Function
22	Reserved			Leave unconnected
23	nAPP		O	Indicates activity of the embedded generic application. When low, the application is active. This can be used for enabling an external sensor only when the generic application is active.
24	Reserved			Leave unconnected
25	VDD			Module power supply.
26	GND			Module ground
27	GND			Module ground
28	GND			Module ground

Table 6: Pin list for module

PU: Pull-up, typical 20k Ω

PU-res: Pull-up 56k

P0-P7: IO's for the Generic Application. See User Guide for details.

Reserved: Pins allocated for future use. Do not connect these. Solder to non connected pad.

5. Dimensions and drawing for NC2400C

Item	Dimension	Tolerance	Remark
Width	11mm	±0.2mm	
Length	18mm	±0.2mm	
Height	2.6mm	±0.25mm	Without U.FL plug

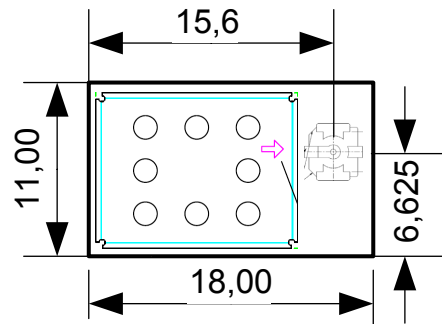

All dimensions are in mm.

Figure 2: Module drawing

6. Module pin-out

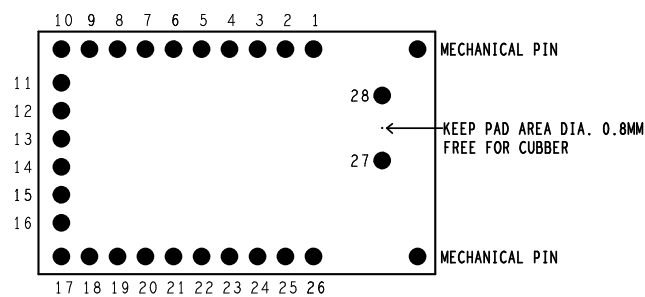
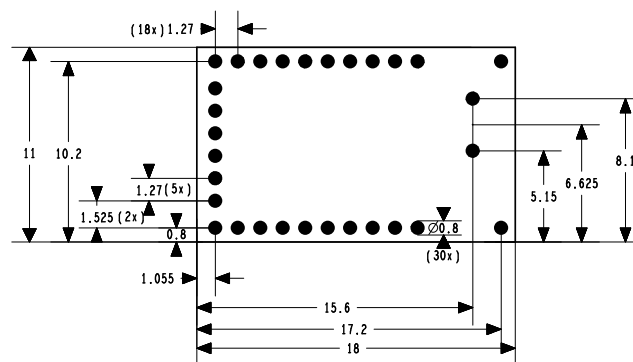

Figure 3: Module pin-out (top-view)

7. PCB Footprint

A recommended footprint is shown here. Please note that no components must be placed under the module.



All dimensions are nominal and in mm.

Figure 4: Module footprint (top-view)

8. Recommended Solder profile

Contact NEOCORTEC for detailed recommendations.

9. Moisture sensitivity level

The module is a MSL3 device as defined in IPC/JEDEC J-STD-033B.1.

10. Ordering information

Model	Temp range	Part number	Remark
NC2400	-40°C -85°C	NC2400C	Module with U.FL connector

11. Package information

Available in 100 pcs tray or tape and reel. Please contact NEOCORTEC for further details.

neo.cortec

Wireless connectivity made simple.



WWW.NEOCORTEC.COM

X-ON Electronics

Largest Supplier of Electrical and Electronic Components

Click to view similar products for [Networking Modules](#) category:

Click to view products by [NeoCortec](#) manufacturer:

Other Similar products are found below :

[MS25041-4-327](#) [DX80N9X1W-PS50G](#) [PCINC1000C-8](#) [NC2400C](#) [PCINC2400C](#) [301-2010-27](#) [301-1010-74](#) [DC-ES-4SB-EU](#) [XPP100300S-04R](#) [CIO-120-DN-P](#) [XPP1003000-04R](#) [MGM111E256V2](#) [XXV710DA2](#) [VSMD001V072](#) [NS5-SQ11B-V2](#) [2000000849](#) [BB-WSW2C00015-1](#) [BB-WSW2C42100-2](#) [WISE-1021WR-1100E](#) [WISE-3310-D200L1E](#) [CDPP8RG](#) [SC14CVMDECT](#) [SF02T](#) [20-101-1328](#) [20-101-1329](#) [DC-ME4-01T-C](#) [X2E-Z1C-W1-W](#) [EAGLE40-2TX/1SFP](#) [EAGLE40-2TX/1SFP-EEC](#) [PuIM-1G4T-I211-BP-R10](#) [PuIM-1G4T-I211-R10](#) [PUZZLE-IN003B-C0/8G-R10](#) [X710DA2](#) [XXV710DA2OCP2](#) [MO11AA003-01R](#) [WP20010NMK-01](#) [XP1001000-05R](#) [XP1001000M-05R](#) [XP1002000-05R](#) [XP100200S-05R](#) [XPDNC2000-01](#) [XPP1002000-02R](#) [XPP100200S-02R](#) [112113-0007](#) [1121130011](#) [SST-DN4-PCU](#) [NS5-SQ10-V2](#) [2200515](#) [113990838](#) [SD-300-US](#) [MGM111A256V2](#)