



NewAE Technology Inc.
newae.com

ChipWhisperer® Embedded Security Analysis Tools
Stand-Alone Targets

CW305 Artix FPGA Target

Product Datasheet

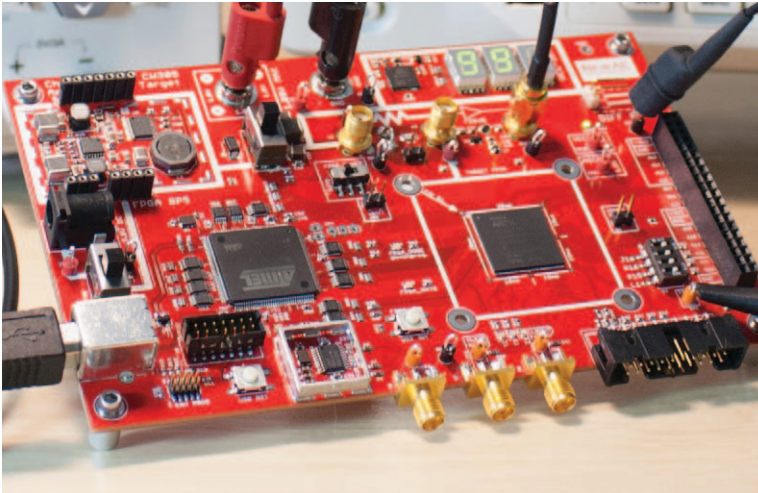

The CW305 is an advanced target for performing power analysis & fault injection attacks against hardware cryptographic functions implemented in FPGAs.

A custom USB interface chip means you can trivially send and receive data to your FPGA design, while also performing FPGA configuration and adjusting external PLL operating frequencies all from the same interface. ESD protection on all I/O lines allows you to perform glitch insertion safely, and an optional BGA socket is perfect for comparing effects across many physical devices.

Product Highlights

Shunt resistor for measurement of power consumption of core implemented on FPGA. Default option of no decoupling capacitors mounted leaves high-frequency signals present across shunt.

ESD protection reduces possibility of resetting USB interface when inserting EM or voltage faults.

Three types of FPGA targets (-A35, -A100, SOCKET) allowing implementation of large cryptographic cores.

Custom USB interface provides simple address/data register set leaving you to concentrate on FPGA core, and not on details of the USB Interface protocol.

Programmable VCC-INT power supply & external oscillators allow you to control external parameters over USB for validation across voltage and frequency.

Ordering Summary

NAE-CW305-04-□-□-□
└─┬─┬─┬─
 └─ Decoupling capacitor options
 └─ Shunt resistor
 └─ FPGA type

Product Links

Full Documentation <http://cwdocs.com/cw305>
Example FPGA Projects https://github.com/newaetech/chipwhisperer/tree/master/hardware/victims/cw305_artixtarget

Specifications

Feature	Notes/Range
FPGA Supported	Artix-7 in FTG256 Package.
FPGA Configuration support	USB (built in), JTAG (requires external tool), SPI Flash memory.
Power Supplies	0.8-1.2V (VCC-INT), 4A, Programmable. 1.8V (VCC-AUX), 1.5A, Fixed. 3.3V (VCC-IO), 2A, Fixed.
USB Interface	Custom high-speed USB 2.0 firmware running on ARM microcontroller.
USB Functions	FPGA configuration, VCC-INT setting, PLL configuration, writing onto data-bus for FPGA.
USB Example Languages	Python (Linux, Windows, Mac OS-X).
USB Supported Language	Any that can access libusb DLL (C, C++, VB, etc).
Supported Toolchains	Xilinx Vivado (All FPGAs), Xilinx ISE (XC7A100T only).
PLL Channels	3 separate frequencies.
PLL Output Range	1-200 MHz.
I/O on Expansion Header	27 GPIO (including 2x differential & 3 clock inputs on FPGA).
I/O on 20-pin Header	11 GPIO (including 1 clock input on FPGA).
I/O on SMA Connectors	2 GPIO (including 1 clock inputs on FPGA).

Detailed Ordering Options

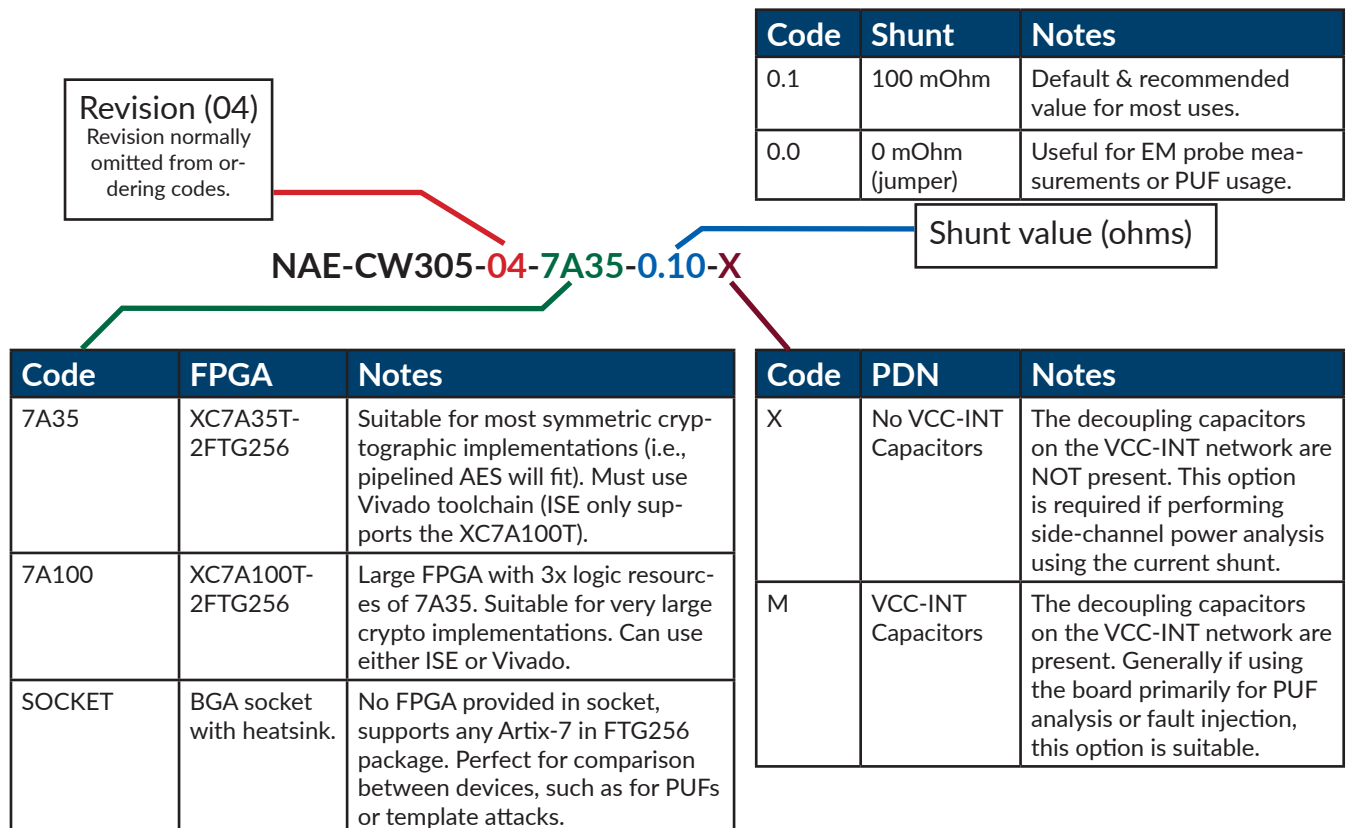

Board Features

Banana jacks simplify connection to bench supply for VCC-INT.

Adjustable VCC-INT regulator (controlled via USB) lets you check PUF operation at different voltages.

VCCIO/VCCAUX regulator with optional low-noise linear add-on.

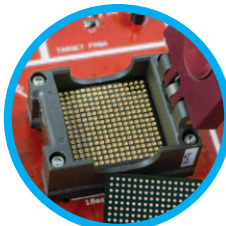

Optional socket available.

SMA connectors for power measurement & voltage fault insertion. +20dB amplified output simplifies connection to scope.

DMM to monitor FPGA core voltage.

VCC-AUX shunt for additional measurement experiments.

PCB targets and mounting holes for X-Y table alignment.

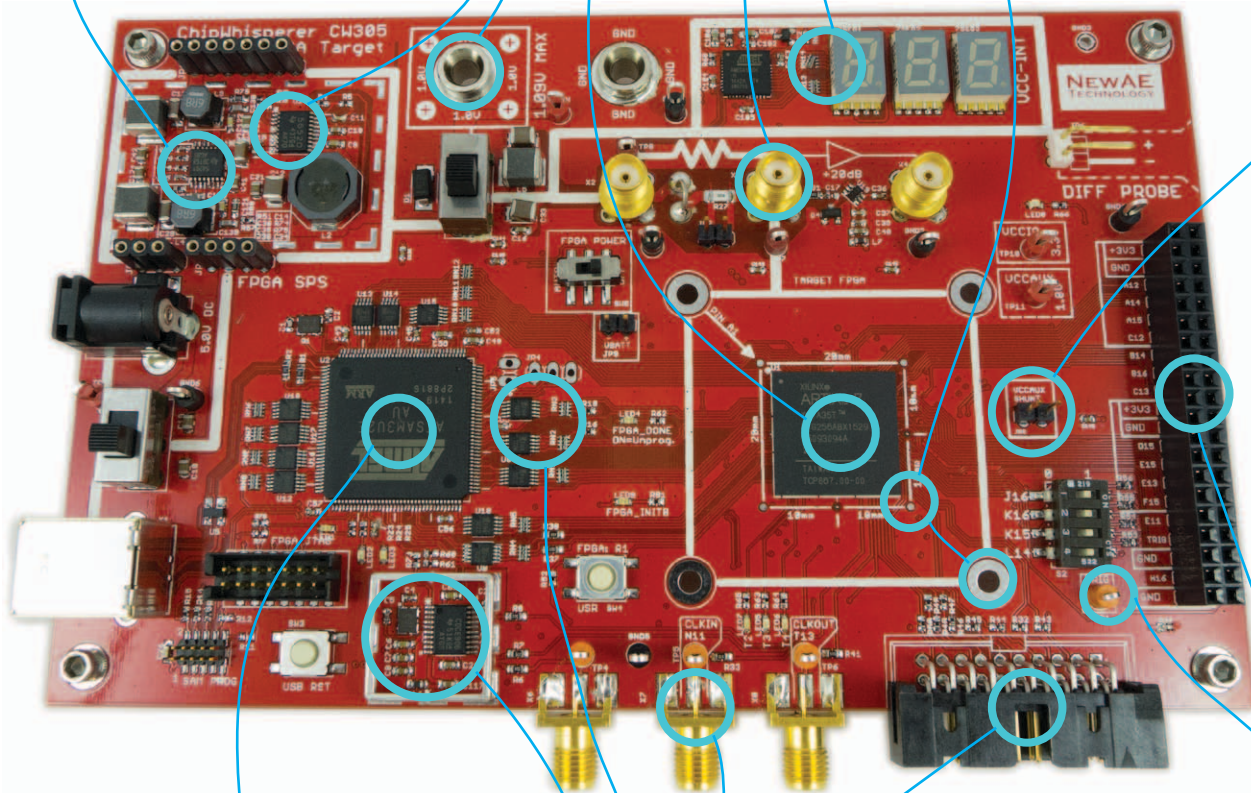

Custom USB interface provides API to directly read/write into FPGA memory space, along with FPGA configuration in 2 seconds.

External PLL generates from 1 MHz - 200 MHz clock frequency for FPGA, perfect for validating SCA or PUF operation at different frequencies, without having to modify the FPGA.

Diode protection to prevent target voltage glitches from affecting USB interface chip.

Numerous test points for use with regular scope.

Expansion header for additional I/O.

20-Pin Connector for ChipWhisperer capture hardware.

SMA connectors for clock input/output.

Socket Usage

Boards ordered with the SOCKET option contain a BGA socket. The following shows a FPGA (upside down) next to the open socket:

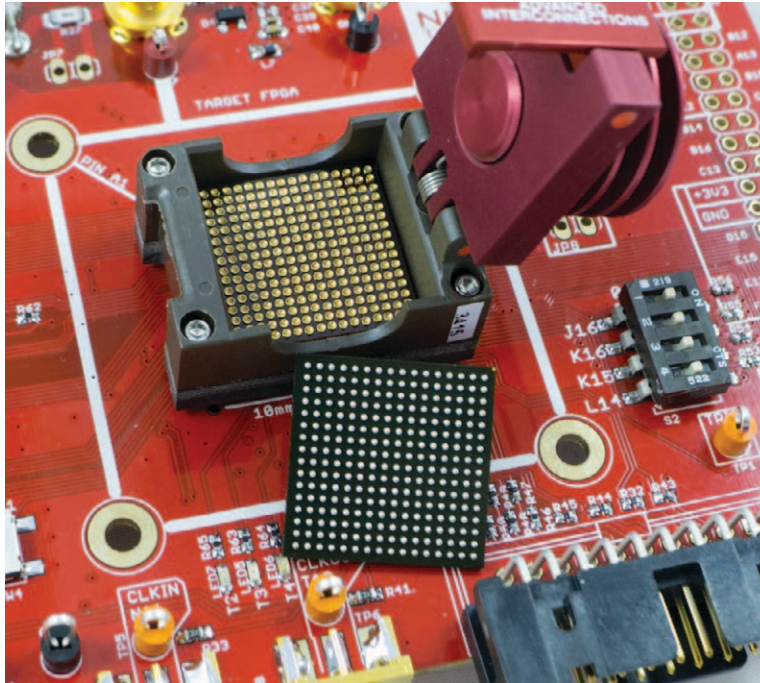

When closed, the socket has a heat sink on top of the FPGA. Note the socket prevents usage with an EM probe or similar.

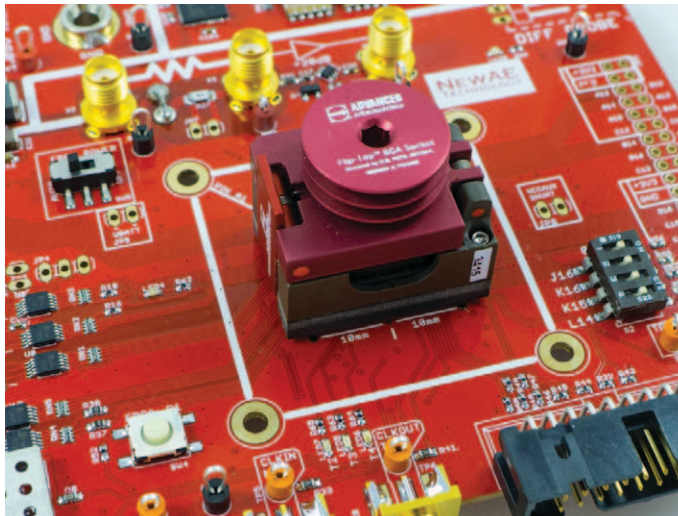

The socket can fit any Artix 7 device in the FT256/FTG256 package. Currently this means the following devices are supported: XC7A15T, XC7A35T, XC7A50T, XC7A75T, XC7A100T. If ordering an FPGA for the socket ensure it is in the FT256/FTG256 package. Note the 'G' package indicates usage of lead-free (Sn/Ag/Cu) solder balls, whereas the FT256 package uses Sn/Pb solder balls. Either will work with the BGA socket.

ChipWhisperer Capture Usage

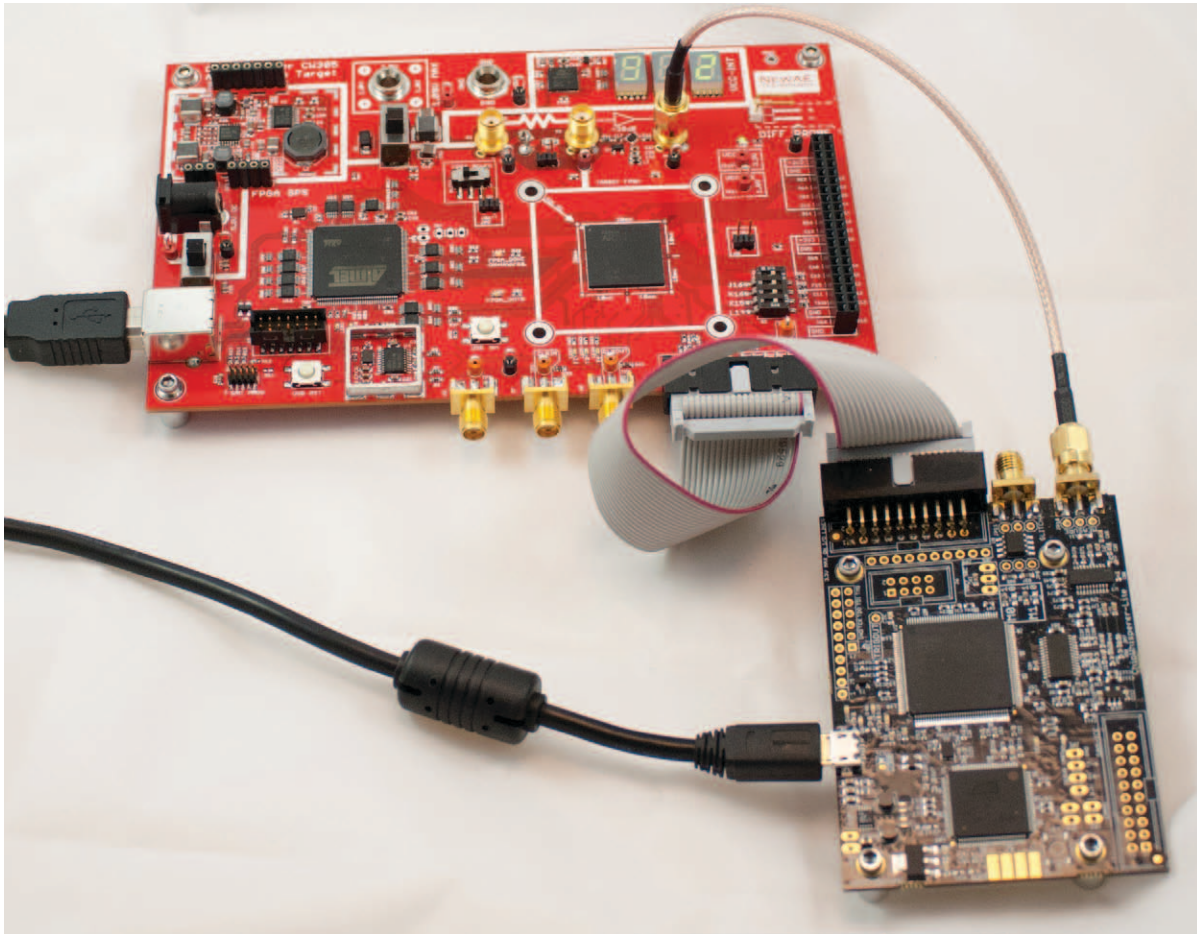

The CW305 can be used with the ChipWhisperer Capture hardware (either CW1173 or CW1200). The ChipWhisperer capture hardware provides power analysis, along with clock and voltage glitching. This forms a complete low-cost and standalone lab that does not require any additional test equipment such as oscilloscopes or power supplies.

See the wiki (at ChipWhisperer.com) for full details and example tutorials of this product.

Disclaimers

All content is Copyright NewAE Technology Inc., 2018. ChipWhisperer is a trademark of NewAE Technology Inc., registered in the United States of America and Europe. ChipSHOUTER is a trademark of NewAE Technology Inc., registered in Europe. Trademarks are claimed in all jurisdictions and may be registered in other states than specified here.

NewAE Technology makes no representations or warranties with respect to the accuracy or completeness of the contents of this document and reserves the right to make changes to specifications and product descriptions at any time without notice. NewAE Technology does not make any commitment to update the information contained herein. NewAE Technology products are not intended, authorized, or warranted for use as components in applications intended to support or sustain life. NewAE Technology products are designed solely for teaching purposes.

All other product names and trademarks are the property of their respective owners, which are in no way associated or affiliated with NewAE Technology Inc. Use of these names does not imply any co-operation or endorsement.

Artix and Spartan are registered trademarks or trademarks of Xilinx, Inc. or its subsidiaries, in the US and/or other countries.

X-ON Electronics

Largest Supplier of Electrical and Electronic Components

Click to view similar products for [Programmable Logic IC Development Tools](#) category:

Click to view products by [NewAE](#) manufacturer:

Other Similar products are found below :

[DK-DEV-5SGXEA7N](#) [SLG4DVKADV](#) [88980182](#) [DEV-17526](#) [DEV-17514](#) [LCMXO3L-SMA-EVN](#) [471-014](#) [80-001005](#) [iCE40UP5K-MDP-EVN](#) [ALTHYDRAC5GX](#) [ALTNITROC5GX](#) [471-015](#) [Hinj](#) [SnoMakrR10](#) [DK-DEV-1SDX-P-A](#) [DK-DEV-1SDX-P-0ES](#) [DK-DEV-1SMC-H-A](#) [DK-DEV-1SMX-H-0ES](#) [DK-DEV-1SMX-H-A](#) [DK-DEV-4CGX150N](#) [DK-DEV-5CGTD9N](#) [DK-DEV-5CSXC6N](#) [DK-DEV-5M570ZN](#) [DK-MAXII-1270N](#) [DK-SI-1SGX-H-A](#) [DK-SI-1STX-E-0ES](#) [DK-SI-1STX-E-A](#) [DK-SI-5SGXEA7N](#) [ATF15XX-DK3-U](#) [SLG46824V-DIP](#) [SLG46826V-DIP](#) [240-114-1](#) [6003-410-017](#) [ICE40UP5K-B-EVN](#) [DK-SOC-1SSX-L-D](#) [ICE5LP4K-WDEV-EVN](#) [L-ASC-BRIDGE-EVN](#) [LC4256ZE-B-EVN](#) [LCMXO2-7000HE-B-EVN](#) [LCMXO3D-9400HC-B-EVN](#) [LCMXO3L-6900C-S-EVN](#) [LF-81AGG-EVN](#) [LFE3-MEZZ-EVN](#) [LIF-MD6000-ML-EVN](#) [LPTM-ASC-B-EVN](#) [M2S-HELLO-FPGA-KIT](#) [VIDEO-DC-USXGMII](#) [12GSDIFMCCD](#) [SFP+X4FMCCD](#) [NAE-CW305-04-7A100-0.10-X](#)