

Ordering a market-ready enclosure® is made fast and affordable with our complete in-house capabilities. New Age provides machined openings to fit your PCB, pad printing for your graphics, custom enclosures, custom colors, final assembly, testing and fulfillment services to save you additional time and money. Ask your representative for a free quote today 805-595-1310.

Fast and Affordable Customization

**CNC Modifications
Pad Printing
Colored Resins
EMI/RF Shielding
Custom Enclosure
Assembly & Testing**

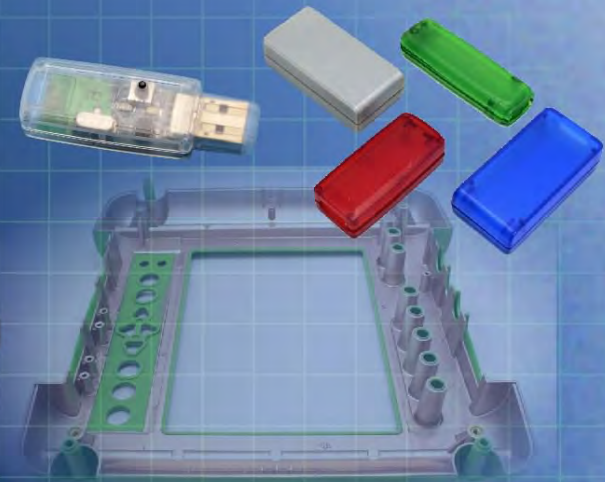
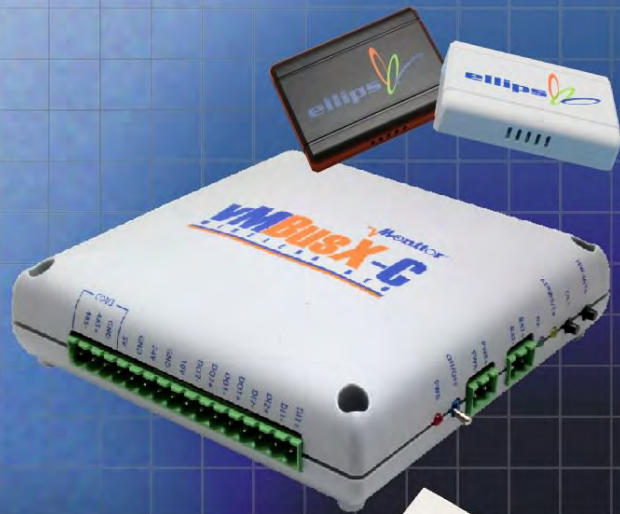

ISO quality
off-the-shelf
to market-ready®

NEW AGE ENCLOSURES

www.NewAgeEnclosures.com

4330 Santa Fe Road • San Luis Obispo, CA 93401 • T 805.595.1310 • F 805.595.1024

P260906(x) CONFIGURATIONS		
	-S	-U
P260906 COVER	1	
P260906 COVER w/ USB		1
P260906 BASE	1	
P260906 BASE w/ USB		1

ITEM	DESCRIPTION	MATERIAL	COLOR	QTY.
4	M2 SCREW x 4mm - REFERENCE	CUSTOMER SUPPLIED	CUSTOMER SUPPLIED	4
3	260906 COVER - STANDARD	ABS	BLACK or WHITE	1
2	260906 BASE - STANDARD	ABS	BLACK or WHITE	1
1	260906 PCB - REFERENCE	CUSTOMER SUPPLIED	.062" THICK	1

BILL OF MATERIALS

R E V I S I O N					
REV.	DRAWN BY	ECO No	DESCRIPTION	DATE	APPROVED
1	M BOYER		PRELIMINARY RELEASE	08-Apr-08	D.C.
2	M BOYER	3408	REMOVE SHOWN USB CUTOUT	22-Oct-08	D.C.
3	M BOYER	0109	PUT USB CUTOUT BACK AS A MOLDING OPTION	15-Jan-09	D.C.
4	M BOYER	0210	SHOW ONE PCB	27-Jan-10	D.C.
4.1	M BOYER	0710	UPDATE FORMAT	20-Mar-10	D.C.
4.2	M BOYER	3310	UPDATE BOM	31-Aug-10	D.C.
4.3	M BOYER	0411	UPDATE LABEL RECESS TO AS-BUILT	10-Feb-11	D.C.
4.4	M BOYER	1211	INCLUDE PCB SCREW INFORMATION	11-Apr-11	D.C.
4.5	M BOYER	1911	UPDATE PCB HOLE RECOMMENDATIONS	26-May-11	D.C.
4.6	M BOYER	2711	CHANGE ASSEMBLY DIMENSIONS TO "PRESS FIT"	21-Oct-11	D.C.
5.0	M BOYER	1113	UPDATE TO AS BUILT	18-Mar-13	D.C.
5.1	R CRUZ	3013	UPDATE TEXTURE CALLOUT	04-Jun-13	D.C.
5.2	R CRUZ	1614	REMOVE PCB SCREW PART NUMBER	02-Apr-14	

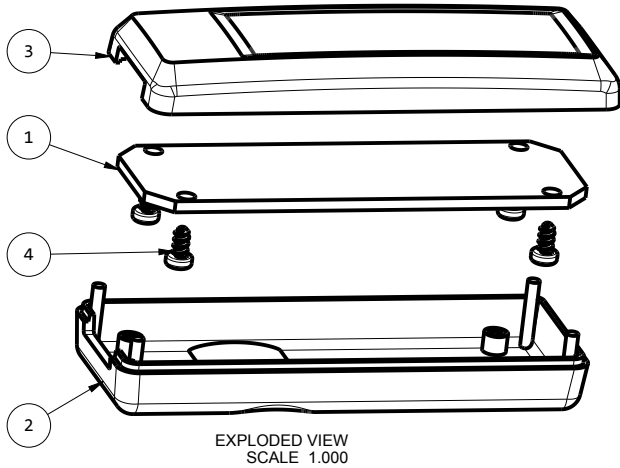

MOLDED CUTOUT
(OPTIONAL)
FOR TYPE A USB
ON STANDARD PCB
ATTACHED TO COVER

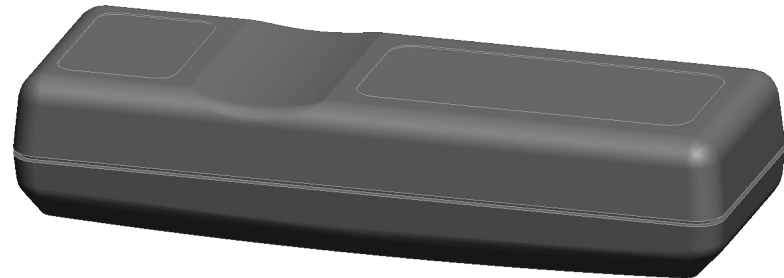
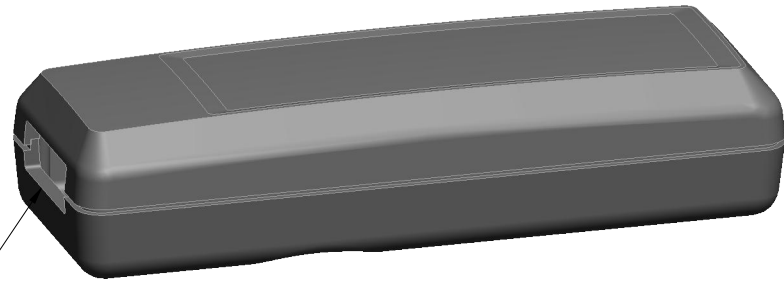

NOTES: UNLESS OTHERWISE SPECIFIED

- CORNERS DRAWN SHARP TO BE R.005 MAXIMUM.
- EXTERIOR SURFACE TEXTURE TO BE LIGHT EDM FINISH. EQUIVALENT TO MT-11020.
- INTERIOR SURFACE TEXTURE: NONE
- ALL INSIDE RADII .010R. UNLESS OTHERWISE SPECIFIED.
- ALL EXTERNAL DIMENSIONS AFFECTED BY THE DRAFT APPLY AT THE LARGE END OF THE FEATURE, AND ALL INTERNAL FEATURES AFFECTED BY THE DRAFT APPLY AT THE SMALL END OF THE FEATURE UNLESS OTHERWISE SPECIFIED.
- 1 DEGREE DRAFT IN THE DIRECTION OF PULL IS PERMISSIBLE UNLESS OTHERWISE SPECIFIED.
- THIS ENCLOSURE IS A PRESS FIT ASSEMBLY. FOR PERMANENT CLOSURE: A DROP OF ADHESIVE OR ULTRASONIC WELDING IS REQUIRED.
- MOUNTING SCREWS FOR THE PCB ARE CUSTOMER SUPPLIED.
- MATERIAL / COLOR: ABS PLASTIC IS STANDARD IN BLACK OR WHITE. CUSTOM MATERIALS AND COLORS ARE AVAILABLE UPON REQUEST FOR QUOTE.
- PCB SIZES ARE RECOMMENDATIONS ONLY. FINAL SIZES AND VERIFICATION OF ITS FIT ARE THE SOLE RESPONSIBILITY OF EACH CUSTOMER.
- STANDARD OR CUSTOM LABEL RECESSES ARE AVAILABLE FOR QUOTE.

THIRD ANGLE PROJECTION DO NOT SCALE DRAWING	TOLERANCES: UNLESS OTHERWISE SPECIFIED DIMENSIONS ARE IN U.S. INCHES. X.XX = .015 X.XXXX = .001 X.XXX = .010 X.X" = 1"	NEW AGE ENCLOSURES 4330 Santa Fe Road San Luis Obispo, CA. 93401 ph. (805) 595-1310 fax (805) 595-1024 www.newageenclosures.com	
	NEW AGE ENCLOSURES Customer's Part No: 260906		
NOTICE: THE INFORMATION AND DATA CONTAINED HEREIN IS CONSIDERED PROPRIETARY TO ALLTEC INTEGRATED MFG INC & SHALL REMAIN THE EXCLUSIVE PROPERTY OF ALLTEC INTEGRATED MFG INC. THE HOLDER WILL ASSUME CUSTODY AND CONTROL THAT THIS DOCUMENT WILL NOT BE COPIED, REPRODUCED, OR DISCLOSED WITHOUT THE EXPRESS WRITTEN CONSENT OF ALLTEC INTEGRATED MFG INC. POSSESSION OF THIS DOCUMENT DOES NOT CONSTITUTE A GRANT TO MANUFACTURE ANY ITEMS. © 2014	APPROVAL BY DATE CHECK ENG. SCALE AS NOTED DRAWN BY M BOYER 08-Apr-08	SIZE A DRAWING NAME 260906_R5_2	SHEET 1 OF 6 REV.DOC 5.2

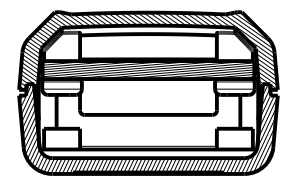
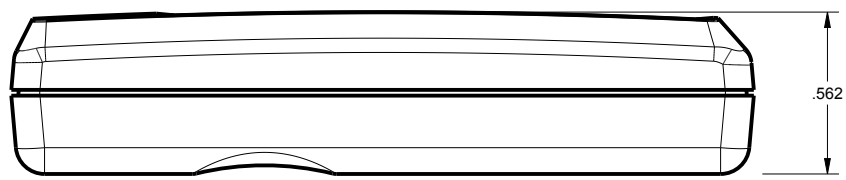
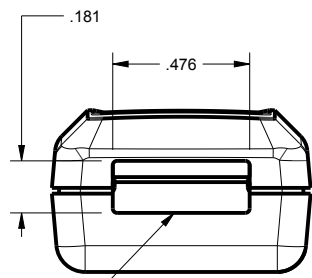
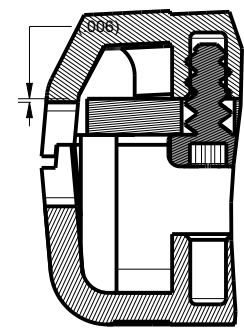
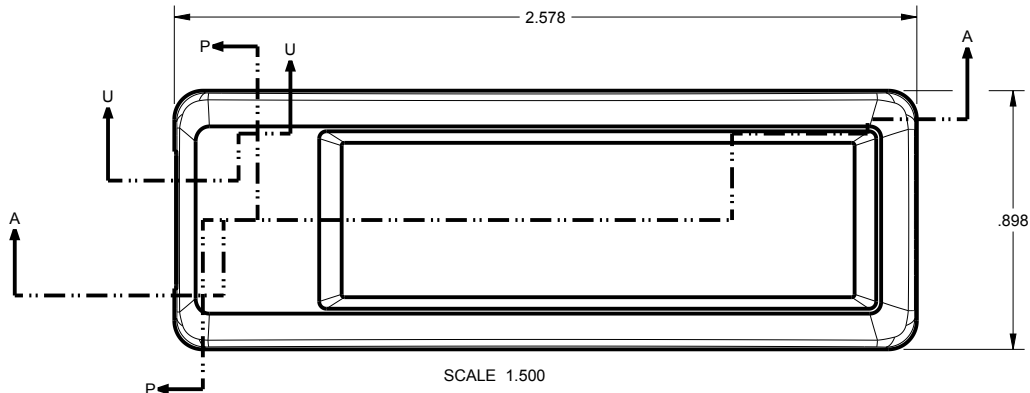

PCB MOUNTED TO 260906 COVER, BUT ALTERNATE PCB MOUNTING POSTS ARE AVAILABLE IN THE BASE. ALTERNATE POST HEIGHT MAY BE REQUIRED TO ALIGN STANDARD USB OPENING. VARIOUS POST HEIGHTS ARE AVAILABLE UPON REQUEST FOR QUOTE.

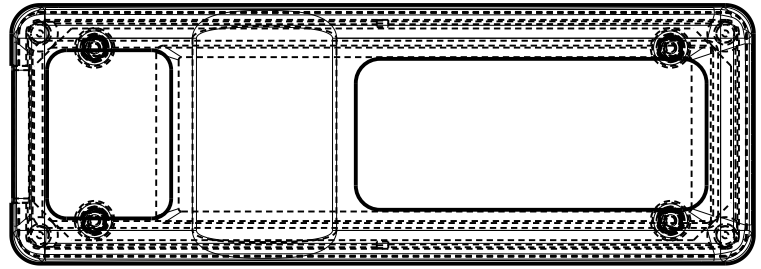
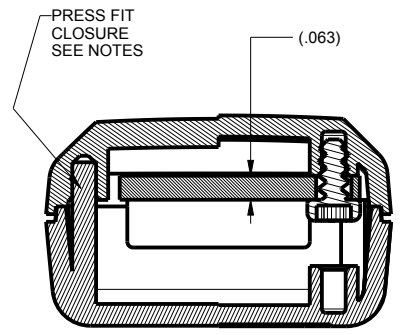
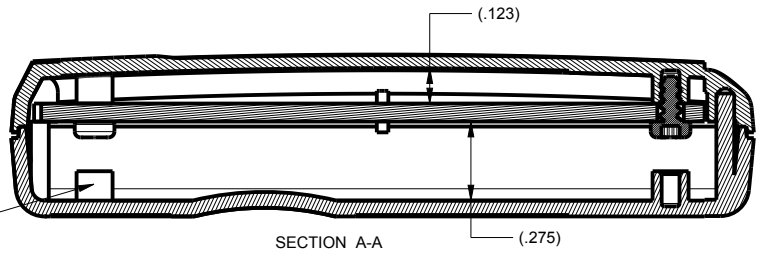

TOLERANCES: UNLESS OTHERWISE SPECIFIED
DIMENSIONS ARE IN U.S. INCHES.
X.XX = .015 X.XXXX = .001
X.XXX = .010 X.X° = 1°

NEW AGE ENCLOSURES
Customer's Part No: 260906

APPROVAL	BY	DATE
CHECK		
ENG.		
SCALE	AS NOTED	

DRAWN BY
M BOYER 08-Apr-08

NEW AGE ENCLOSURES
4330 Santa Fe Road San Luis Obispo, CA. 93401
ph. (805) 595-1310 fax (805) 595-1024
www.newageenclosures.com

**STANDARD - MINI REMOTE
PXX-260906X ASSEMBLY**

SIZE	DRAWING NAME	SHEET	REV.DOC
A	260906_R5_2	2 OF 6	5.2

260906 COVER

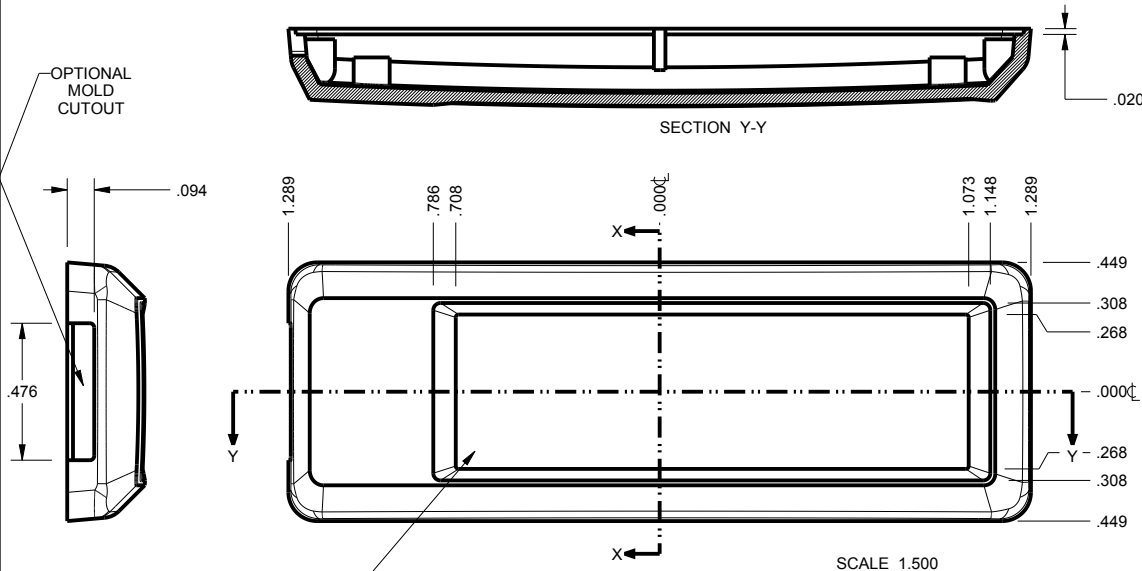

LABEL RECESS AREA AVAILABLE FOR CUSTOM TOOLING

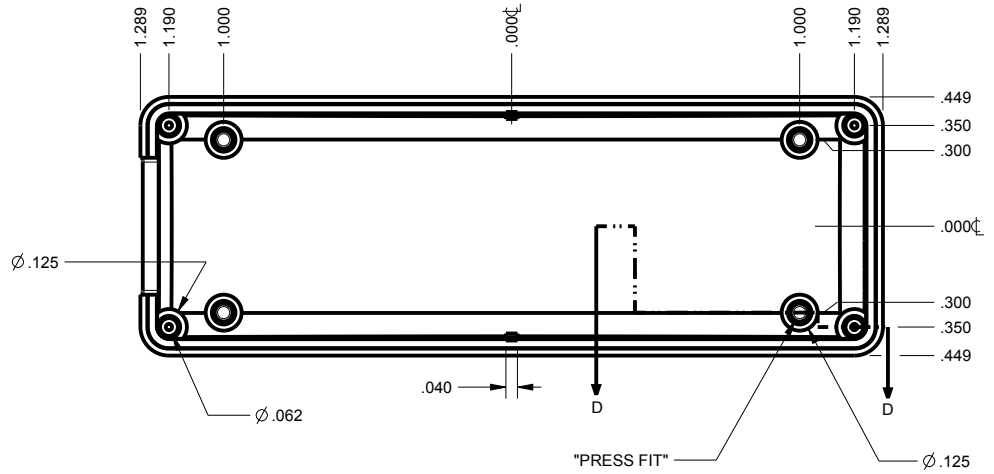
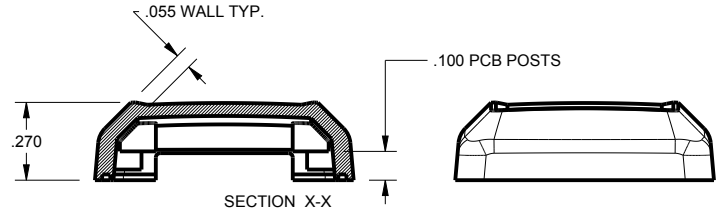
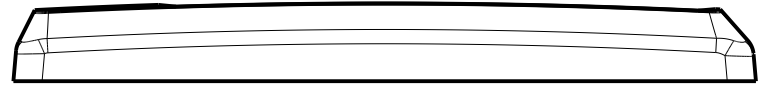
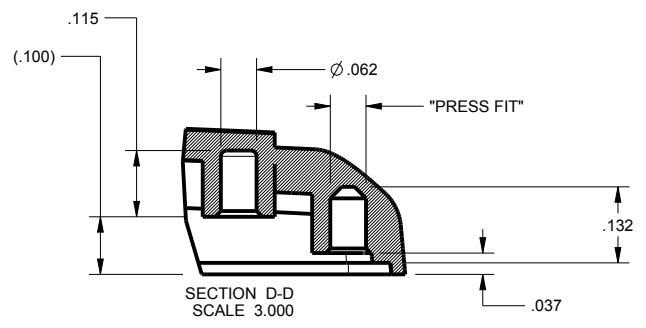

TOLERANCES: UNLESS OTHERWISE SPECIFIED
DIMENSIONS ARE IN U.S. INCHES.
X.XX = .015 X.XXXX = .001
X.XXX = .010 X.X° = 1°

NEW AGE ENCLOSURES
Customer's Part No: 260906

APPROVAL	BY	DATE
CHECK		
ENG.		
SCALE	AS NOTED	

DRAWN BY: M BOYER
DATE: 08-Apr-08

NEW AGE ENCLOSURES

4330 Santa Fe Road San Luis Obispo, CA. 93401
ph. (805) 595-1310 fax (805) 595-1024
www.newageenclosures.com

STANDARD - MINI REMOTE PXX-260906X ASSEMBLY

SIZE	DRAWING NAME	SHEET	REV.DOC
A	260906_R5_2	3 OF 6	5.2

260906 BASE

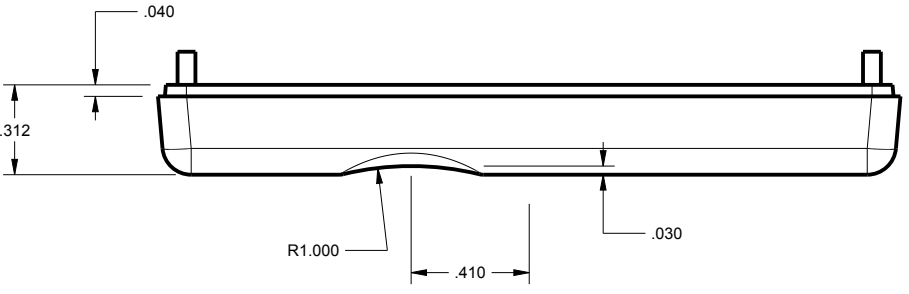
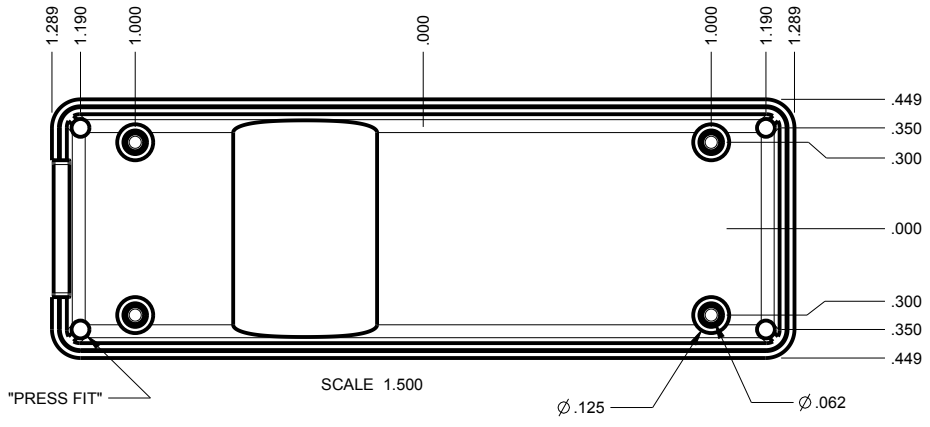
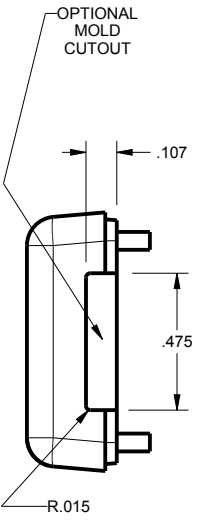
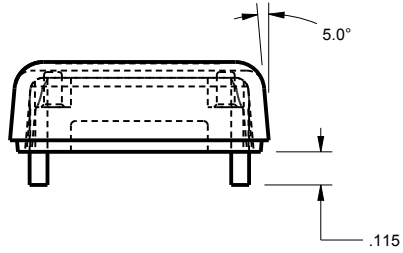
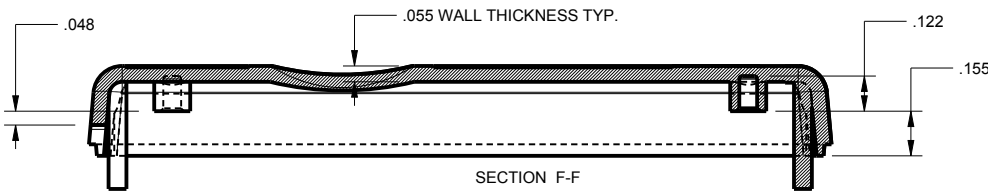
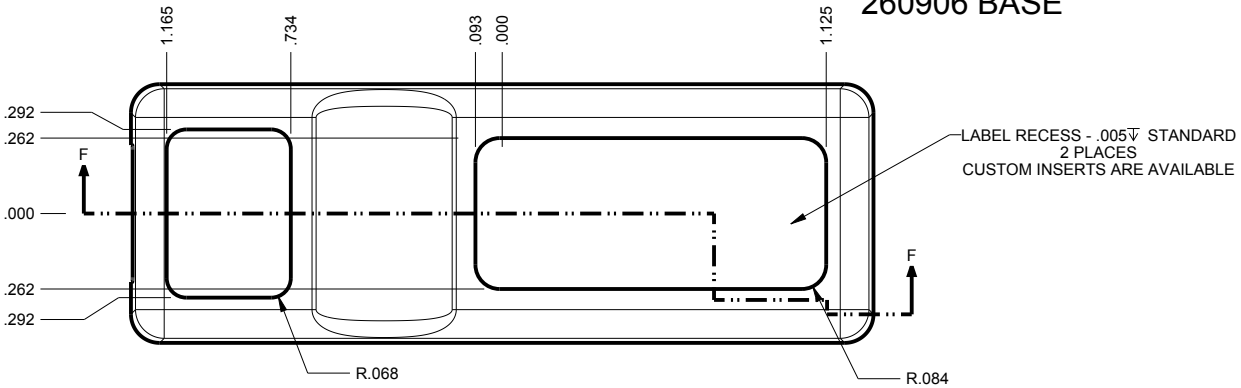

TOLERANCES: UNLESS OTHERWISE SPECIFIED DIMENSIONS ARE IN U.S. INCHES.
 X.XX = .015 X.XXXX = .001
 X.XXX = .010 X.X° = 1°

NEW AGE ENCLOSURES
 Customer's Part No: 260906

APPROVAL	BY	DATE
CHECK		
ENG.		
SCALE	AS NOTED	

DRAWN BY
 M BOYER 08-Apr-08

NEW AGE ENCLOSURES
 4330 Santa Fe Road San Luis Obispo, CA. 93401
 ph. (805) 595-1310 fax (805) 595-1024
www.newageenclosures.com

STANDARD - MINI REMOTE PXX-260906X ASSEMBLY

SIZE	DRAWING NAME	SHEET	REV.DOC
A	260906_R5_2	4 OF 6	5.2

P260906 PCB - CUSTOMER SUPPLIED

PCB SIZES ARE RECOMMENDATIONS ONLY. FINAL SIZES AND VERIFICATION OF ITS FIT ARE THE SOLE RESPONSIBILITY OF THE OEM.

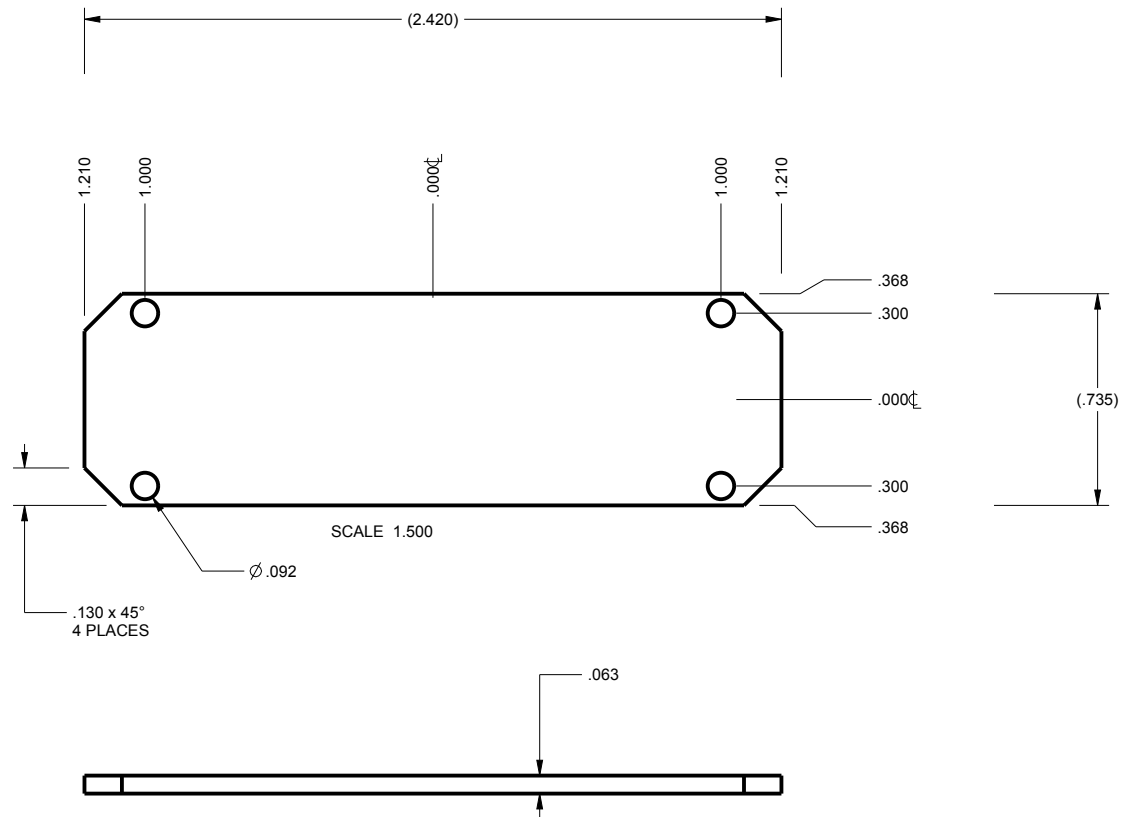

TOLERANCES: UNLESS OTHERWISE SPECIFIED DIMENSIONS ARE IN U.S. INCHES.
 X.XX = .015 X.XXXX = .001
 X.XXX = .010 X.X° = 1°

NEW AGE ENCLOSURES

Customer's Part No: 260906

APPROVAL	BY	DATE
CHECK		
ENG.		
SCALE	AS NOTED	

DRAWN BY
M BOYER 08-Apr-08

NEW AGE ENCLOSURES

4330 Santa Fe Road San Luis Obispo, CA. 93401
 ph. (805) 595-1310 fax (805) 595-1024
www.newageenclosures.com

STANDARD - MINI REMOTE PXX-260906X ASSEMBLY

SIZE	DRAWING NAME	SHEET	REV.DOC
A	260906_R5_2	5 OF 6	5.2

2nd OPERATION DETAILS

NEW AGE ENCLOSURES DELIVERS YOUR ENCLOSURE MARKET-READY WITH IN-HOUSE
CNC MACHINING, PAD PRINTING, ASSEMBLY, AND FULFILLMENT.
ALL SURFACES AND AREAS ARE AVAILABLE FOR CNC ALTERATION BY NEW AGE ENCLOSURES
CALL (805) 595-1310 FOR PRICING AND SCHEDULE.
THE INSIDE RADIUS OF ANY MACHINED FEATURES SHOULD BE NO SMALLER THAN .031"

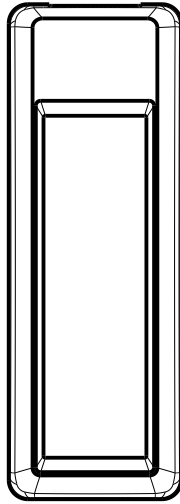
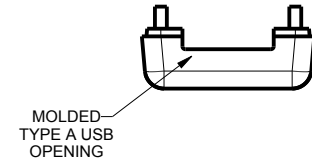
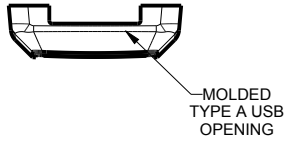

P260906 COVER
SCALE 1.000

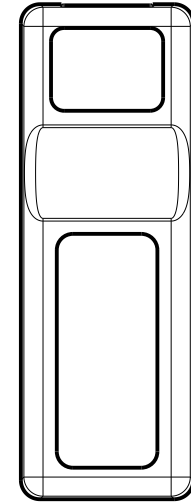
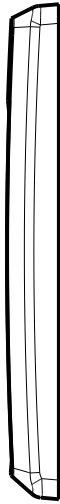

P260906 BASE
SCALE 1.000

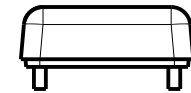
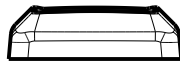

PXX-260906X-XXX COVER - ABS, BLACK

STEP NO	DESCRIPTION	CUTTER	FIXTURE	ORIENTATION	PROGRAM
1	-	T2 = .062" EM	106	-	-
2	-	T2 = .062" EM	106	-	-

PXX-260906X-XXX BASE - ABS, BLACK

STEP NO	DESCRIPTION	CUTTER	FIXTURE	ORIENTATION	PROGRAM
4	-	T2 = .062" EM	106	-	-
5	-	T2 = .062" EM	106	-	-

TOLERANCES: UNLESS OTHERWISE SPECIFIED
DIMENSIONS ARE IN U.S. INCHES.
X.XX = .015 X.XXXX = .001
X.XXX = .010 X.X° = 1°

NEW AGE ENCLOSURES

Customer's Part No: 260906

APPROVAL	BY	DATE
CHECK		
ENG.		
SCALE	AS NOTED	
DRAWN BY	M BOYER 08-Apr-08	

NEW AGE ENCLOSURES

4330 Santa Fe Road San Luis Obispo, CA. 93401
ph. (805) 595-1310 fax (805) 595-1024
www.newageenclosures.com

STANDARD - MINI REMOTE PXX-260906X ASSEMBLY

SIZE	DRAWING NAME	SHEET	REV.DOC
A	260906_R5_2	6 OF 6	5.2

X-ON Electronics

Largest Supplier of Electrical and Electronic Components

Click to view similar products for [Enclosures, Boxes & Cases](#) *category:*

Click to view products by [New Age](#) *manufacturer:*

Other Similar products are found below :

[585-R-WH-PK](#) [M-10-PLATED](#) [60221-01](#) [60566-01-000](#) [HPL-9VB BATT DOOR](#) [M18-PLTD](#) [M-21-PLATED](#) [63310-01-000](#) [6711GSKT](#)
[71884-29-028](#) [LH45-100 Black](#) [72868-510-000](#) [CNS-0000 Black](#) [72883-510-000](#) [CNS-0101 Black](#) [72906-510-000](#) [CNS-0407 Black](#) [73092-](#)
[510-000](#) [CNM-0101 Black](#) [73105-510-000](#) [CNL-0101 Black](#) [73108-510-000](#) [CNL-0303 Black](#) [73395-510-039](#) [CNS-0006 Bone](#) [74257-510-000](#)
[CNL-0004](#) [MDC-1183-PLAIN-ALUM](#) [MDC-1183-PTD](#) [MDC-13104-PTD](#) [MDC-321-PTD](#) [MDC-973-PTD](#) [76](#) [77153-01-028](#) [FLX6030](#)
[83535-01-508](#) [90026-501-000](#) [PS36-200](#) [116-508](#) [120-407](#) [120-910](#) [127-908](#) [130-008](#) [1301170079](#) [1322GSKTEP](#) [1325GSKT3](#) [138-PLAIN](#)
[1434-1210](#) [EAS-500 \(BLACK ANO\)](#) [1804RP-RB-PK](#) [190-005](#) [2202307](#) [KAB3321 BLACK](#) [KAB3421](#) [2697466](#) [S52213](#) [2901107](#) [2901123](#)
[2901699](#) [A0645271](#) [A20P20](#)