

NOTES: UNLESS OTHERWISE SPECIFIED

1. CORNERS DRAWN SHARP TO BE R.005 MAXIMUM.
2. EXTERIOR SURFACE TEXTURE TO BE LIGHT EDM FINISH. EQUIVALENT TO MT-11010. TEXTURE ON ENCLOSURE WILL VARY FROM TIME TO TIME AS THE TOOL WEARS AND IT BECOMES NECESSARY TO REAPPLY.
3. INTERIOR SURFACE TEXTURE TO BE: B3
4. ALL INSIDE RADII .010R. UNLESS OTHERWISE SPECIFIED.
5. ALL EXTERNAL DIMENSIONS AFFECTED BY THE DRAFT APPLY AT THE LARGE END OF THE FEATURE, AND ALL INTERNAL FEATURES AFFECTED BY THE DRAFT APPLY AT THE SMALL END OF THE FEATURE UNLESS OTHERWISE SPECIFIED.
6. ONE DEGREE DRAFT IN THE DIRECTION OF PULL IS PERMISSIBLE UNLESS OTHERWISE SPECIFIED.
7. MATERIAL / COLOR: SEE OPTIONS TABLE FOR STANDARD MATERIAL AND COLOR OPTIONS. CUSTOM MATERIALS AND COLORS ARE AVAILABLE UPON REQUEST FOR QUOTE. ALTERNATE RESINS HAVE DIFFERENT SHRINK RATES, AND WILL EFFECT DIMENSIONS.
8. PCB SIZES ARE RECOMMENDATIONS ONLY. FINAL SIZES AND VERIFICATION OF ITS FIT ARE THE SOLE RESPONSIBILITY OF EACH CUSTOMER.
9. THIS DRAWING IS BASED ON A SOLID MODEL, AND IS FURTHER DEFINED BY THE SOLID MODEL FILE.
10. ALLOWABLE FLASH: 0.010 MAX.
11. ALL EJECTOR PIN MARKS TO BE WITHIN 0.010" OF FLUSH, PROTRUDING OR BELOW FLUSH.
12. TRIM GATE WITHIN 0.030" OF FLUSH.
13. REFERENCE THE PRODUCT SPEC AND SERVICE GUIDE.

R E V I S I O N					
REV.	DRAWN BY	ECO No	DESCRIPTION	DATE	APPROVE
A	M BOYER		PRELIMINARY RELEASE	2021-Sep-08	J.T.
B	M BOYER		REVISE HOLES AFTER 1st PRINT	2021-Sep-13	J.T.
C	M BOYER		CHANGE MOUNTING SLOTS PER REVIEW 210928	2021-Oct-11	J.T.
D	M BOYER		INCLUDE FAN MOUNT PER 211019 REVIEW	2021-Oct-26	J.T.
E	M BOYER		UPDATE PER REVIEW 211026	2021-Oct-27	J.T.
F	M BOYER		UPDATE PER REVIEW 211028	2021-Oct-28	J.T.
G	M BOYER		UPDATE PER REVIEW 211102	2021-Nov-02	J.T.
H	M BOYER		UPDATE PER REVIEW Jan 10, 2022	2022-Jan-10	

PXX-382613 CONFIGURATION TREE	
MATERIAL, COLOR	PREFIX
ABS, WHITE	P1A-
ABS, BLACK	P3A-
POLYCARBONATE, CLEAR	P0P-
POLYCARBONATE, SEMI-TRANSLUCENT DARK RED	P2P-
POLYCARBONATE, SEMI-TRANSLUCENT SMOKE GRAY	P4P-
POLYCARBONATE, SEMI-TRANSLUCENT BLUE	P7P-
POLYCARBONATE, SEMI-TRANSLUCENT GREEN	P8P-

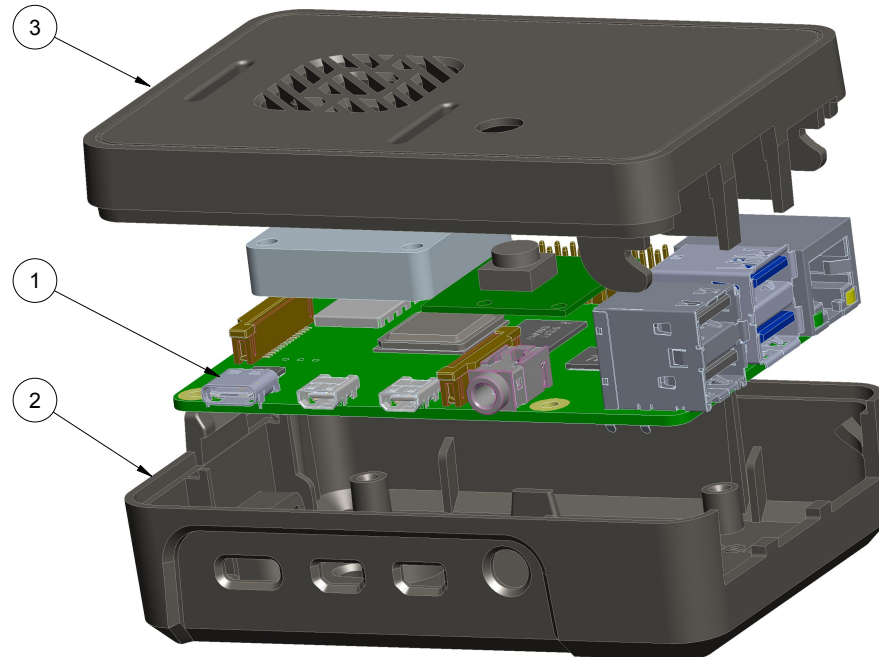

SCALE 0.900

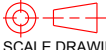
<b>THIRD ANGLE PROJECTION</b>  DO NOT SCALE DRAWING	TOLERANCES: UNLESS OTHERWISE SPECIFIED DIMENSIONS ARE IN U.S. INCHES. X.XX = .015 X.XXXX = .001 X.XXX = .010 X.X" = 1"	<b>NEW AGE ENCLOSURES</b> 2240 South Thornburg Street Santa Maria, CA. 93455 ph. (805) 595-1310 fax (805) 595-1024 <a href="http://www.newageenclosures.com">www.newageenclosures.com</a>
	<b>NEW AGE ENCLOSURES</b> Customer's Part No: 382613	
APPROVAL BY DATE CHECK _____ ENG. _____ SCALE AS NOTED		<b>RASPBERRY Pi 4 ENCLOSURE</b> <b>PXX-382613-XXX</b>
DRAWN BY M BOYER 2021-Sep-08 SIZE A DRAWING NAME 382613_RH SHEET 1 OF 4 REV.DOC H		

ITEM	FILE NAME	DESCRIPTION	MATERIAL	COLOR	QTY.
3	382613_COVER	382613 COVER - STANDARD	SEE TREE	SEE TREE	1
2	382613_BASE	382613 BASE - STANDARD	SEE TREE	SEE TREE	1
1	RASPBERRY-PI4	Raspberry Pi 4 Model B	REFERENCE ONLY	CUSTOMER SUPPLIED	1

**BILL OF MATERIALS**

NOTICE: THE INFORMATION AND DATA CONTAINED HEREIN IS CONSIDERED PROPRIETARY TO ALLTEC INTEGRATED MFG INC & SHALL REMAIN THE EXCLUSIVE PROPERTY OF ALLTEC INTEGRATED MFG INC. THE HOLDER WILL ASSUME CUSTODY AND CONTROL THAT THIS DOCUMENT WILL NOT BE COPIED, REPRODUCED, OR DISCLOSED WITHOUT THE EXPRESS WRITTEN CONSENT OF ALLTEC INTEGRATED MFG INC. THIS DOCUMENT DOES NOT CONSTITUTE A GRANT TO MANUFACTURE ANY ITEMS. © 2022

# 382613 ASSEMBLY

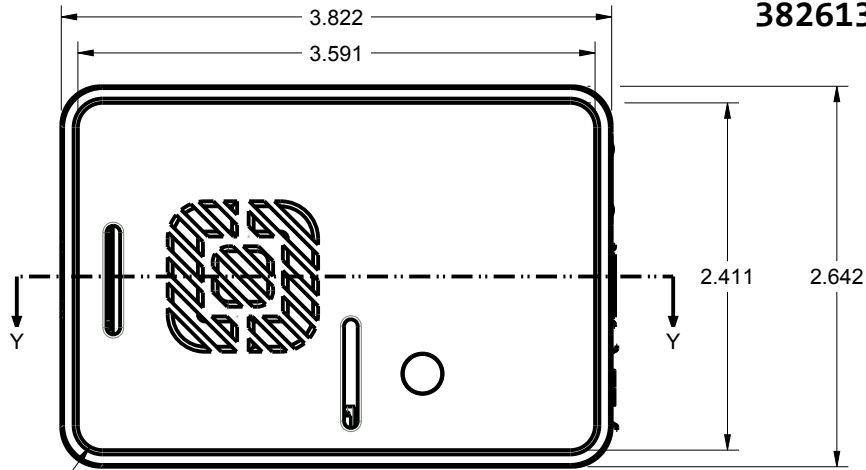

4X R.175

SCALE 0.750

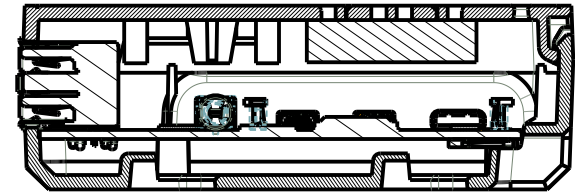
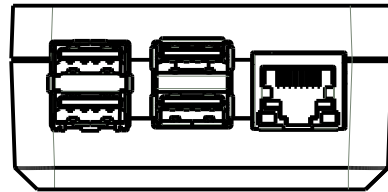
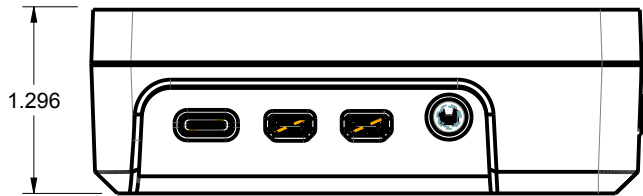

SECTION Y-Y

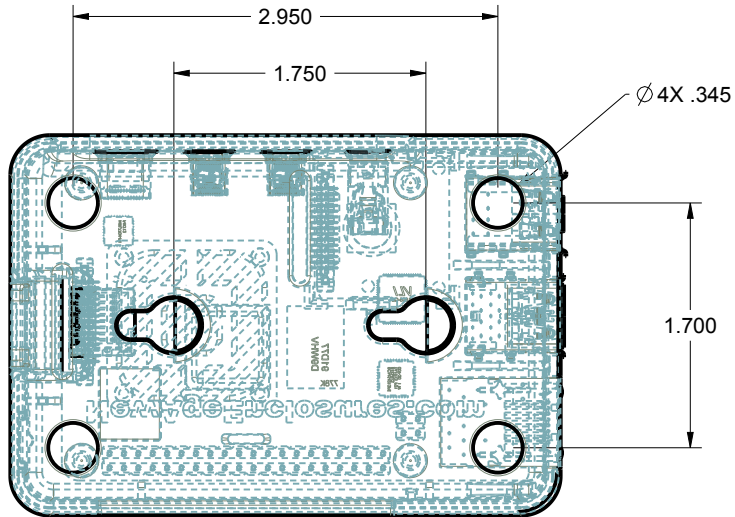

TOLERANCES: UNLESS OTHERWISE SPECIFIED  
DIMENSIONS ARE IN U.S. INCHES.  
X.XX = .015 X.XXXX = .001  
X.XXX = .010 X.X° = 1°

NEW AGE ENCLOSURES  
Customer's Part No: 382613

APPROVAL	BY	DATE
CHECK		
ENG.		
SCALE	AS NOTED	
DRAWN BY		
M BOYER	2021-Sep-08	

**NEW AGE ENCLOSURES**  
2240 South Thornburg Street Santa Maria, CA. 93455  
ph. (805) 595-1310 fax (805) 595-1024  
www.newageenclosures.com

**RASPBERRY Pi 4 ENCLOSURE  
PXX-382613-XXX**

SIZE	DRAWING NAME	SHEET	REV.DOC
A	382613_RH	2 OF 4	H

# 382613 COVER

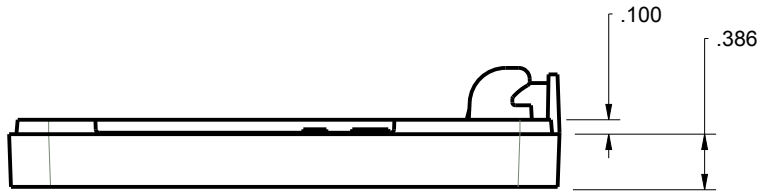

- ① REFERENCE COMPONENTS THAT FIT:  
 - EasyCargo EDL3007S05 Raspberry pi 4 Cooling Fan  
 - Weewooday 5 Megapixel Camera Sensor Module OV5647

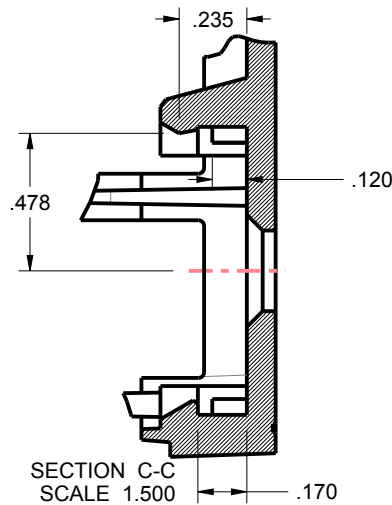
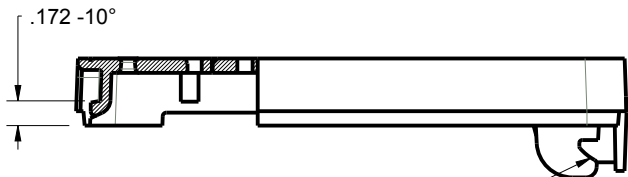
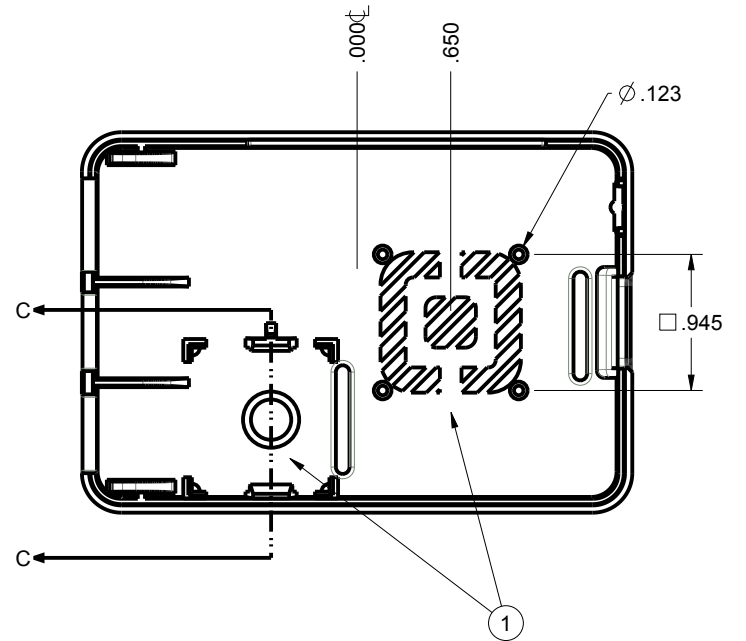
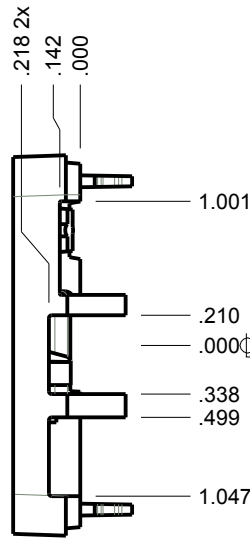
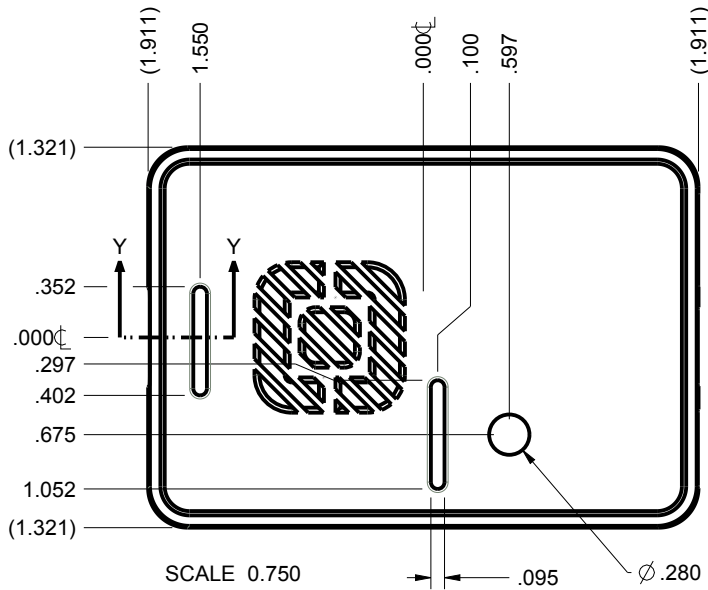

TOLERANCES: UNLESS OTHERWISE SPECIFIED  
 DIMENSIONS ARE IN U.S. INCHES.  
 X.XX = .015 X.XXXX = .001  
 X.XXX = .010 X.X° = 1°

**NEW AGE ENCLOSURES**  
 2240 South Thornburg Street Santa Maria, CA. 93455  
 ph. (805) 595-1310 fax (805) 595-1024  
[www.newageenclosures.com](http://www.newageenclosures.com)

Customer's Part No: 382613

APPROVAL	BY	DATE
CHECK		
ENG.		
SCALE	AS NOTED	

**RASPBERRY Pi 4 ENCLOSURE**  
**PXX-382613-XXX**

DRAWN BY  
 M BOYER 2021-Sep-08

SIZE A DRAWING NAME  
 382613\_RH

SHEET 3 OF 4 REV.DOC H

# 382613 BASE

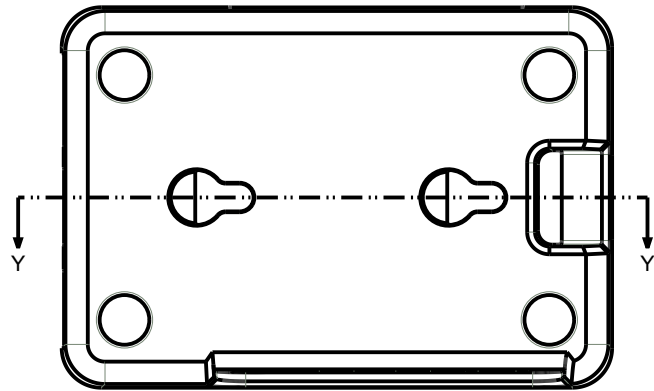
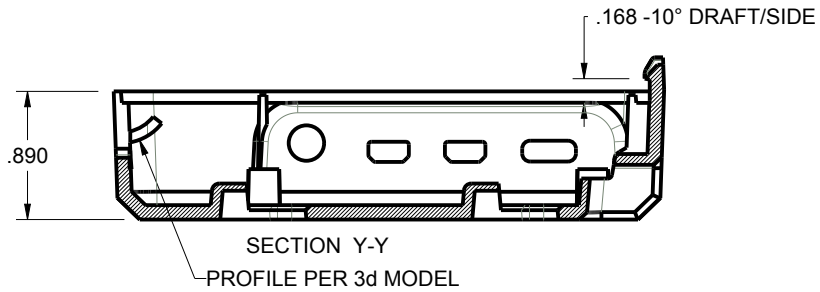

SCALE 0.750

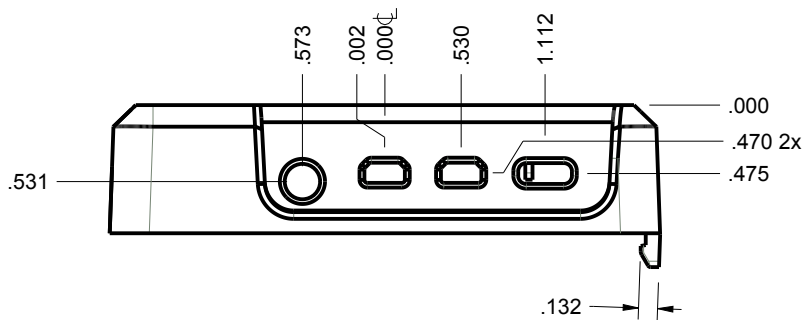
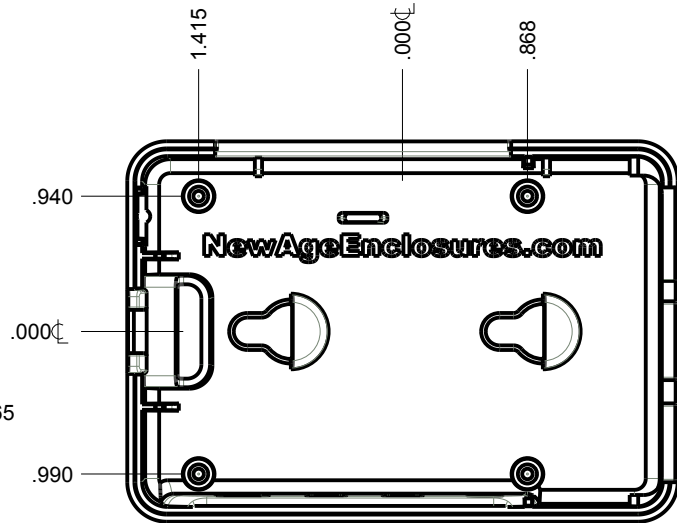
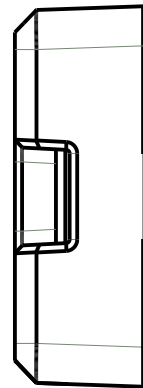

TOLERANCES: UNLESS OTHERWISE SPECIFIED  
DIMENSIONS ARE IN U.S. INCHES.  
X.XX = .015 X.XXXX = .001  
X.XXX = .010 X.X° = 1°

NEW AGE ENCLOSURES

Customer's Part No: 382613

APPROVAL BY DATE

CHECK

ENG.

SCALE AS NOTED

DRAWN BY M BOYER 2021-Sep-08

**NEW AGE ENCLOSURES**

2240 South Thornburg Street Santa Maria, CA. 93455  
ph. (805) 595-1310 fax (805) 595-1024  
www.newageenclosures.com

RASPBERRY Pi 4 ENCLOSURE  
PXX-382613-XXX

SIZE A DRAWING NAME 382613\_RH SHEET 4 OF 4 REV.DOC H

## X-ON Electronics

Largest Supplier of Electrical and Electronic Components

*Click to view similar products for* [Enclosures for Single Board Computing](#) *category:*

*Click to view products by* [New Age](#) *manufacturer:*

Other Similar products are found below :

[3005](#) [5292](#) [PS-11596-B](#) [1593HAMAR3BK](#) [1593HAMAR3GY](#) [1593HAMAR3TBU](#) [1593HAMARBK](#) [1593HAMARGY](#) [1593HAMARTBU](#)  
[2258](#) [1593HAMPI3CLR](#) [1593HAMPI3GY](#) [PS-11595-W](#) [PS-11594-B](#) [2366](#) [2368](#) [PS-11595-C](#) [1593HAMPI3TBU](#) [1593HAMPI3BK](#) [3252](#)  
[PRT-12845](#) [FIT0417](#) [FIT0499](#) [PRT-12846](#) [PRT-14025](#) [3471](#) [1319](#) [1555](#) [2033](#) [2082](#) [2244](#) [2245](#) [2246](#) [2248](#) [2257](#) [2303](#) [2335](#) [2360](#) [2362](#)  
[2364](#) [2370](#) [2372](#) [4340](#) [4341](#) [4486](#) [4490](#) [4553](#) [4822](#) [PS-11594-W](#) [cs-lime-02](#)