

NOTES: UNLESS OTHERWISE SPECIFIED

1. CORNERS DRAWN SHARP TO BE R.010 MAXIMUM.
2. EXTERIOR SURFACE TEXTURE TO BE MT-11020, UNLESS SPECIFIED OTHERWISE. TEXTURE ON ENCLOSURE WILL VARY FROM TIME TO TIME AS THE TOOL WEARS AND IT BECOMES NECESSARY TO REAPPLY.
3. ALL INSIDE RADII .020R. UNLESS OTHERWISE SPECIFIED.
4. ALL EXTERNAL DIMENSIONS AFFECTED BY THE DRAFT APPLY AT THE LARGE END OF THE FEATURE, AND ALL INTERNAL FEATURES AFFECTED BY THE DRAFT APPLY AT THE SMALL END OF THE FEATURE UNLESS OTHERWISE SPECIFIED.
5. 1 DEGREE DRAFT IN THE DIRECTION OF PULL IS PERMISSIBLE UNLESS OTHERWISE SPECIFIED.
6. MATERIAL / COLOR: ASA PLASTIC IS STANDARD IN BLACK OR GRAY. SLIGHT COSMETIC SWIRLING, BLUSHING, AND/OR DISCOLORATION CAN OCCUR IN THIS ENCLOSURE DUE TO UV INHIBITORS IN THE RESIN. CUSTOM MATERIALS AND COLORS ARE AVAILABLE UPON REQUEST FOR QUOTE. ALTERNATE RESINS HAVE DIFFERENT SHRINK RATES, AND WILL EFFECT DIMENSIONS.
7. PCB SIZES ARE RECOMMENDATIONS ONLY. FINAL SIZES AND VERIFICATION OF ITS FIT ARE THE SOLE RESPONSIBILITY OF EACH CUSTOMER.
8. ASSEMBLY SCREWS FOR THE ENCLOSURE INCLUDED. MOUNTING SCREWS FOR THE PCB ARE CUSTOMER SUPPLIED.
9. THIS DRAWING IS BASED ON A SOLID MODEL, AND IS FURTHER DEFINED BY THE SOLID MODEL FILE.
10. ALLOWABLE FLASH: 0.010 MAX.
11. ALL EJECTOR PIN MARKS TO BE WITHIN 0.010" OF FLUSH, PROTRUDING OR BELOW FLUSH.
12. TRIM GATE WITHIN 0.030" OF FLUSH.
13. THIS ENCLOSURE IS CONSTRUCTED FOR INDOOR OR OUTDOOR USE TO PROVIDE A DEGREE OF PROTECTION TO THE EQUIPMENT INSIDE AGAINST THE INGRESS OF SOLID FOREIGN OBJECTS (FALLING DIRT); AND TO PROVIDE A DEGREE OF PROTECTION WITH RESPECT TO TO HARMFUL EFFECTS ON THE EQUIPMENT DUE TO THE INGRESS OF WATER (DRIPPING OR SPLASHING).

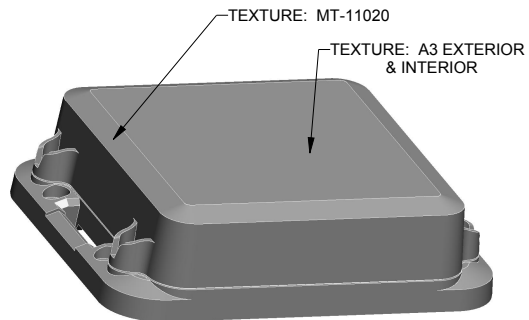

SCALE 0.400

R E V I S I O N					
REV.	DRAWN BY	ECO No	DESCRIPTION	DATE	APPROVE
E	M BOYER	PDCL2101	DEVELOPED FROM SXXXXX	2020-Jan-21	D.C.
F	M BOYER		PER REVIEW May 4, 2021	2021-May-04	J.T.
G	M BOYER		PER REVIEW July 20, 2021	2021-Jul-20	

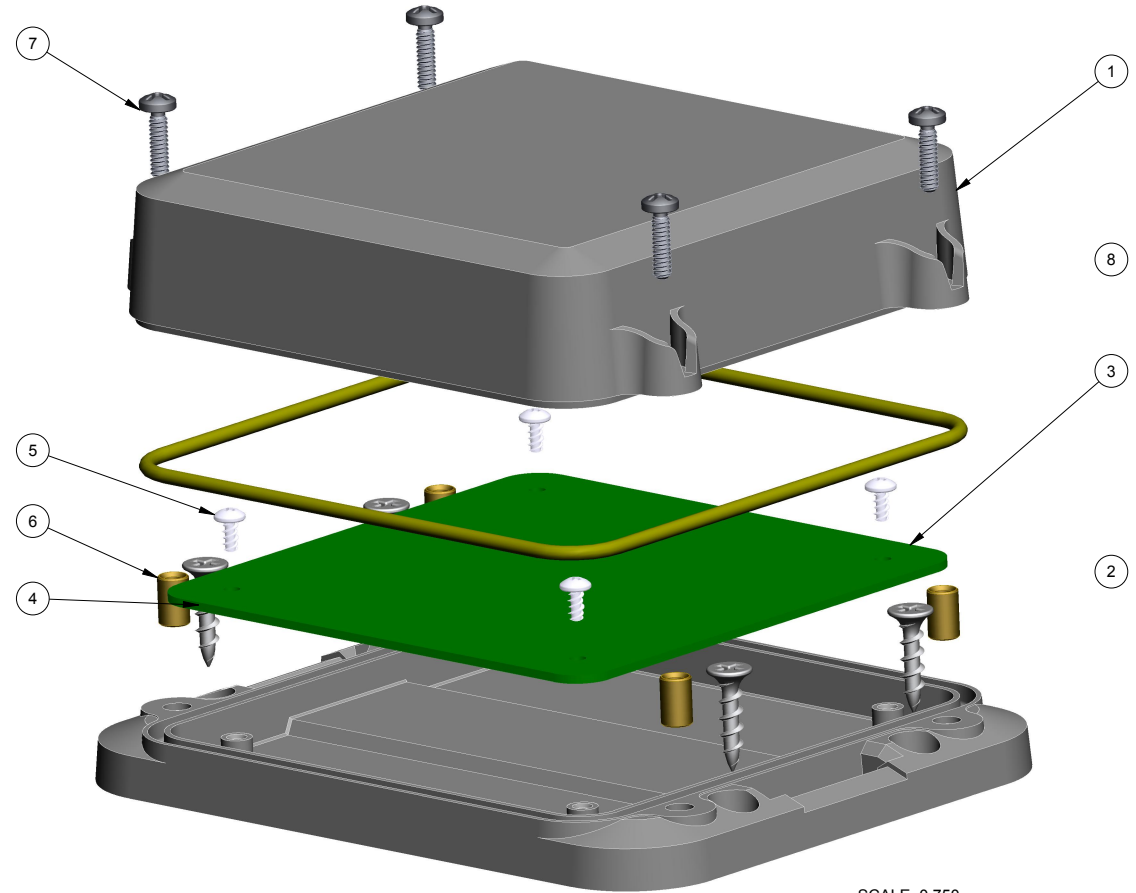

SCALE 0.750

ITEM	FILE NAME	DESCRIPTION	MATERIAL	COLOR	QTY.
8	444414_ORING	OR-159 ORING	SHORE 70A	VARIES	1
7	6-32_PHILLIPS_SCREW	6-32 PHILLIPS SCREW x .375"	18-8 STAINLESS	S-MS 6-32.375	4
6	6-32X344_BRASS-INSERT	6-32 BRASS INSERT x .344"	632x344MB	OVER-MOLDED	4
5	SCREW_HILO-N04	#4 HILO SCREW x .250"	ZINC PLATED	CUSTOMER SUPPLIED	4
4	SCREW-DRYWALLX750	DRYWALL SCREW	REFERENCE ONLY	CUSTOMER SUPPLIED	4
3	444414_PCB	444414 PCB - REFERENCE	.062" THICK	CUSTOMER SUPPLIED	1
2	444414_WALL-BASE	444414 WALL BASE - STANDARD	ASA	BLACK or GRAY	1
1	444414_COVER	444414 COVER - STANDARD	ASA	BLACK or GRAY	1

BILL OF MATERIALS

THIRD ANGLE PROJECTION

 DO NOT SCALE DRAWING

TOLERANCES: UNLESS OTHERWISE SPECIFIED
 DIMENSIONS ARE IN U.S. INCHES.
 X.XX = .015 X.XXXX = .001
 X.XXX = .010 X.X" = 1"

NEW AGE ENCLOSURES
 Customer's Part No: 444414

APPROVAL	BY	DATE
CHECK		
ENG.		
SCALE	AS NOTED	

DRAWN BY
 M BOYER
 2021-Apr-12

NEW AGE ENCLOSURES
 2240 South Thornburg Street Santa Maria, CA. 93455
 ph. (805) 595-1310 fax (805) 595-1024
www.newageenclosures.com

**LARGE OUTDOOR NODE - STANDARD
 SXL-444414-XXX**

SIZE	DRAWING NAME	SHEET	REV.DOC
A	444414_RG	1 OF 7	G

444414 ASSEMBLY

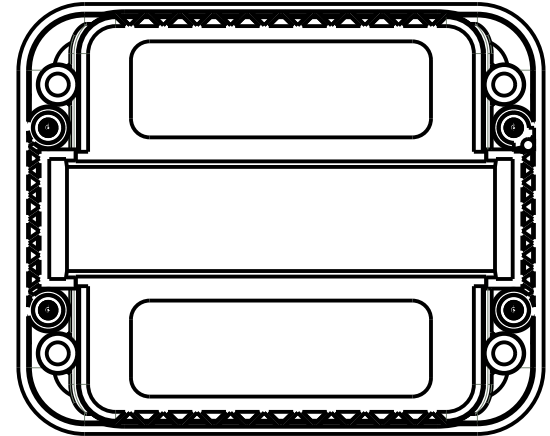
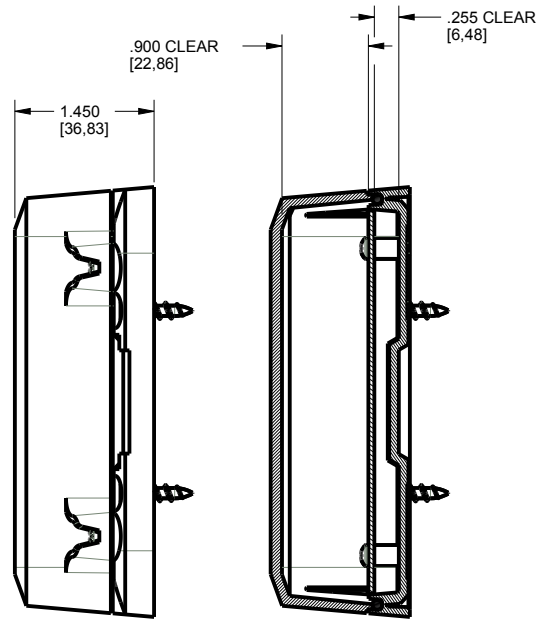
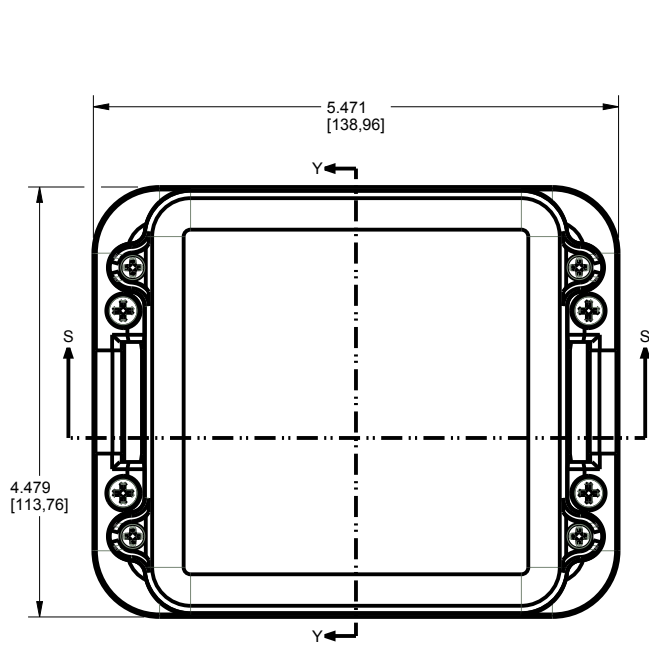

SCALE 0.500

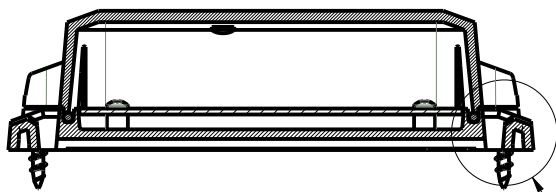

SEE DETAIL A

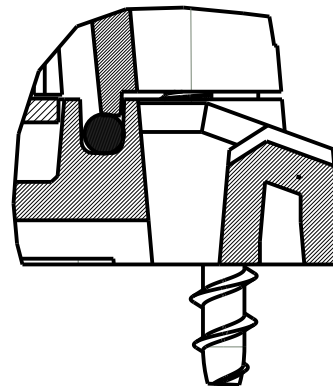

SCALE 2.000

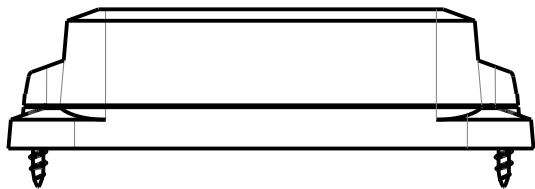
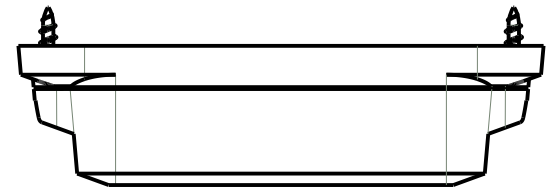

TOLERANCES: UNLESS OTHERWISE SPECIFIED
DIMENSIONS ARE IN U.S. INCHES.
X.XX = .015 X.XXXX = .001
X.XXX = .010 X.X° = 1°

NEW AGE ENCLOSURES

Customer's Part No: 444414

APPROVAL	BY	DATE
CHECK		
ENG.		
SCALE	AS NOTED	

DRAWN BY: M BOYER
DATE: 2021-Apr-12

NEW AGE ENCLOSURES

2240 South Thornburg Street Santa Maria, CA. 93455
ph. (805) 595-1310 fax (805) 595-1024
www.newageenclosures.com

LARGE OUTDOOR NODE - STANDARD
SXL-444414-XXX

SIZE: A	DRAWING NAME: 444414_RG	SHEET: 2 OF 7	REV.DOC: G
---------	-------------------------	---------------	------------

444414 COVER

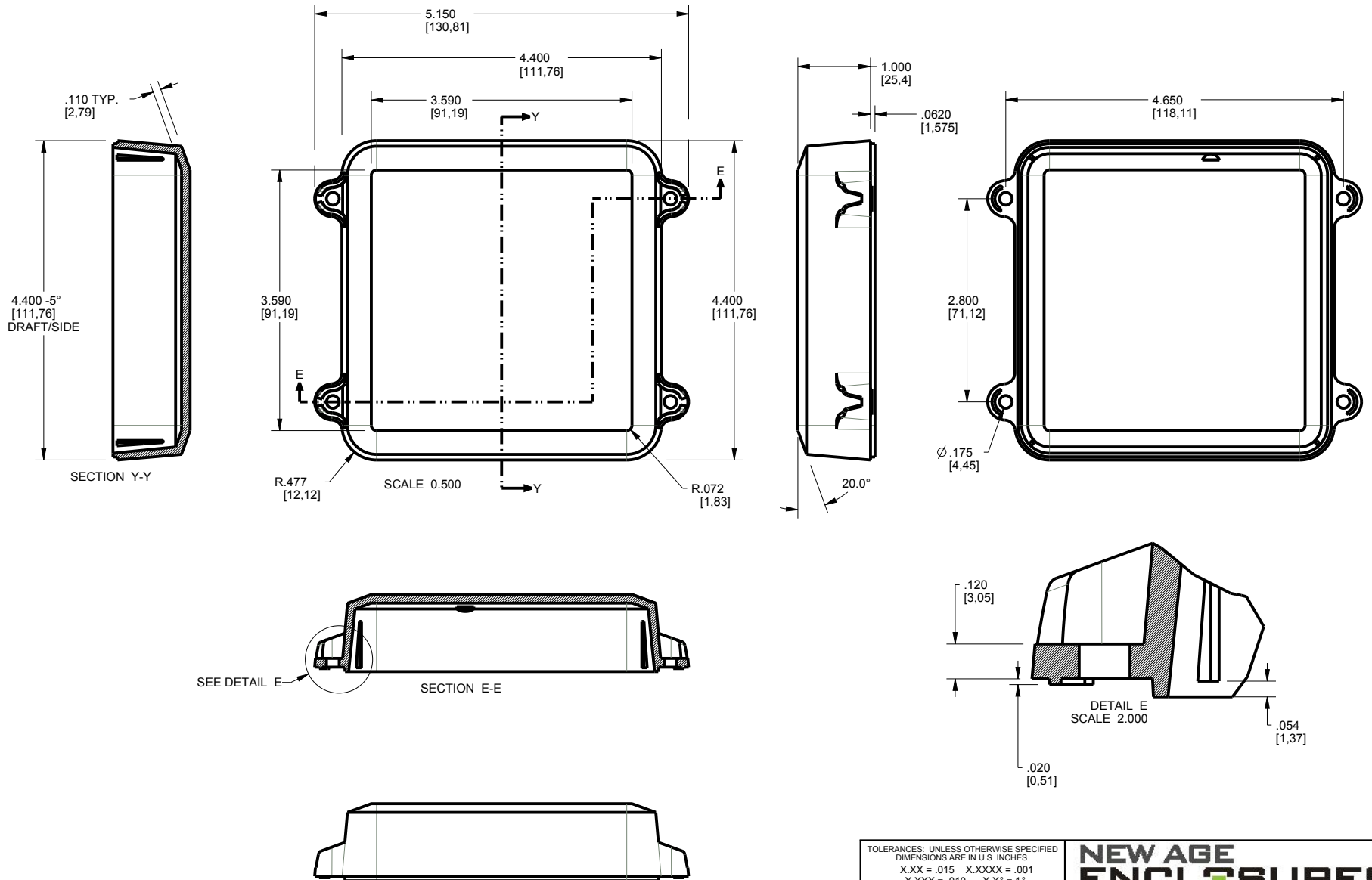

TOLERANCES: UNLESS OTHERWISE SPECIFIED
DIMENSIONS ARE IN U.S. INCHES.
X.XX = .015 X.XXXX = .001
X.XXX = .010 X.X° = 1°

NEW AGE ENCLOSURES
2240 South Thornburg Street Santa Maria, CA. 93455
ph. (805) 595-1310 fax (805) 595-1024
www.newageenclosures.com

Customer's Part No: 444414

APPROVAL	BY	DATE
CHECK		
ENG.		
SCALE	AS NOTED	

LARGE OUTDOOR NODE - STANDARD
SXL-444414-XXX

DRAWN BY: M BOYER
DATE: 2021-Apr-12

SIZE: A
DRAWING NAME: 444414_RG

SHEET: 3 OF 7
REV.DOC: G

444414 WALL BASE

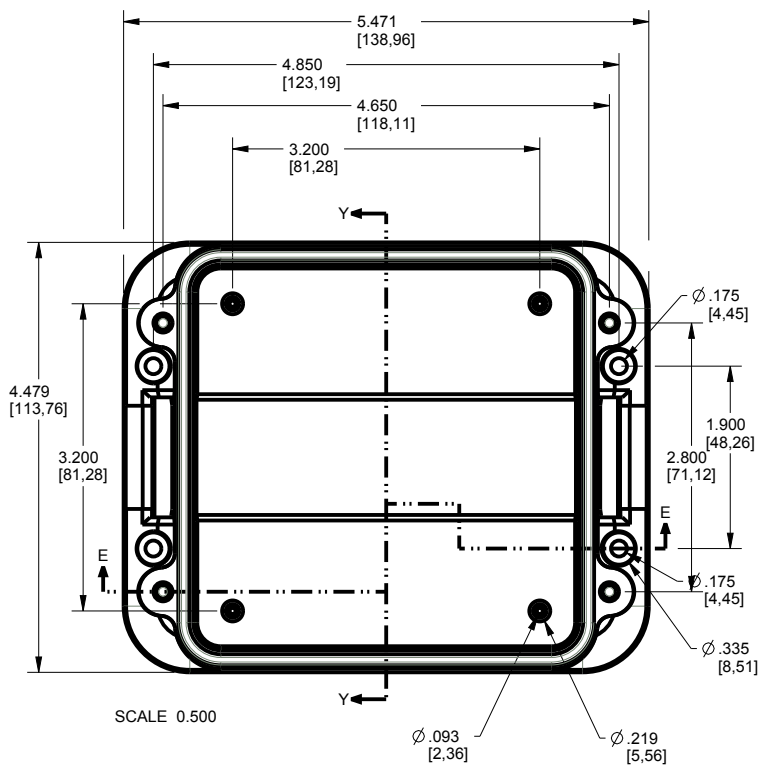

SCALE 0.500

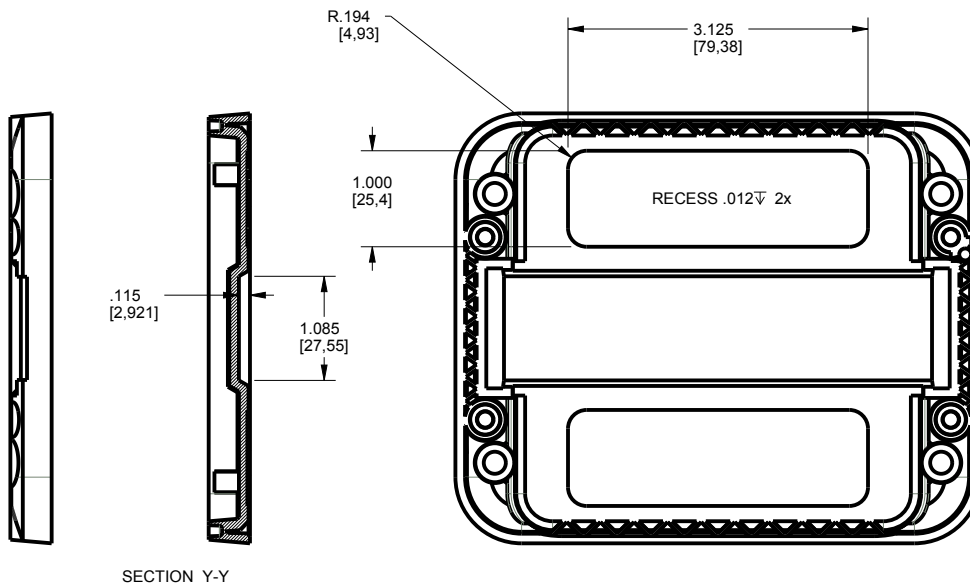

SECTION Y-Y

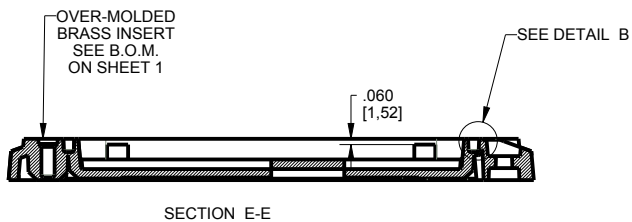

SECTION E-E

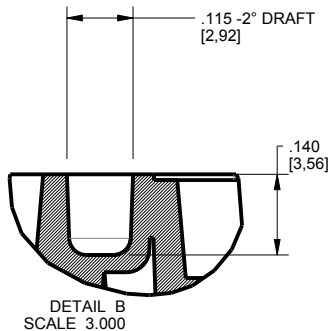

DETAIL B
SCALE 3.000

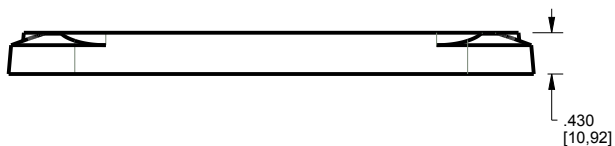

TOLERANCES - UNLESS OTHERWISE SPECIFIED DIMENSIONS ARE IN U.S. INCHES.

X.XX = .015 X.XXXX = .001
X.XXX = .010 X.X° = 1°

NEW AGE ENCLOSURES

Customer's Part No: 444414

APPROVAL BY DATE

CHECK

ENG.

SCALE AS NOTED

DRAWN BY M BOYER 2021-Apr-12

NEW AGE ENCLOSURES

2240 South Thornburg Street Santa Maria, CA. 93455
ph. (805) 595-1310 fax (805) 595-1024

www.newageenclosures.com

LARGE OUTDOOR NODE - STANDARD
SXL-444414-XXX

SIZE A DRAWING NAME 444414_RG SHEET 4 OF 7 REV.DOC G

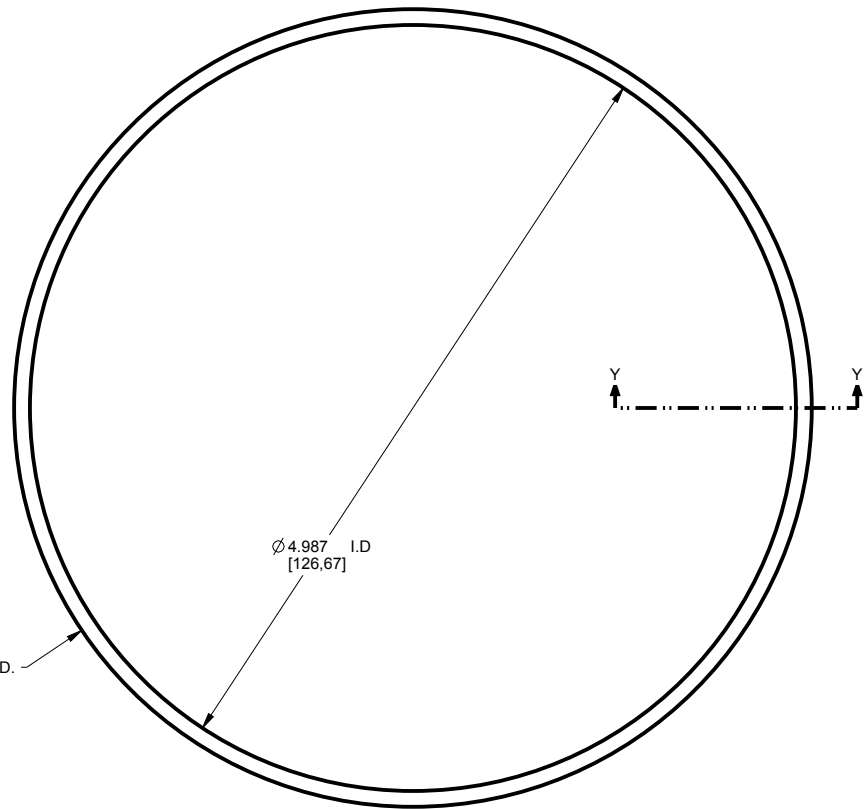

OFF THE SHELF O-RING #159
SCALE 0.800



SECTION Y-Y

SEE DETAIL D

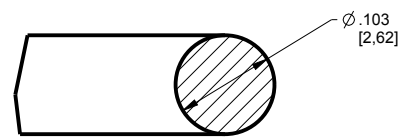

DETAIL D
SCALE 5.000

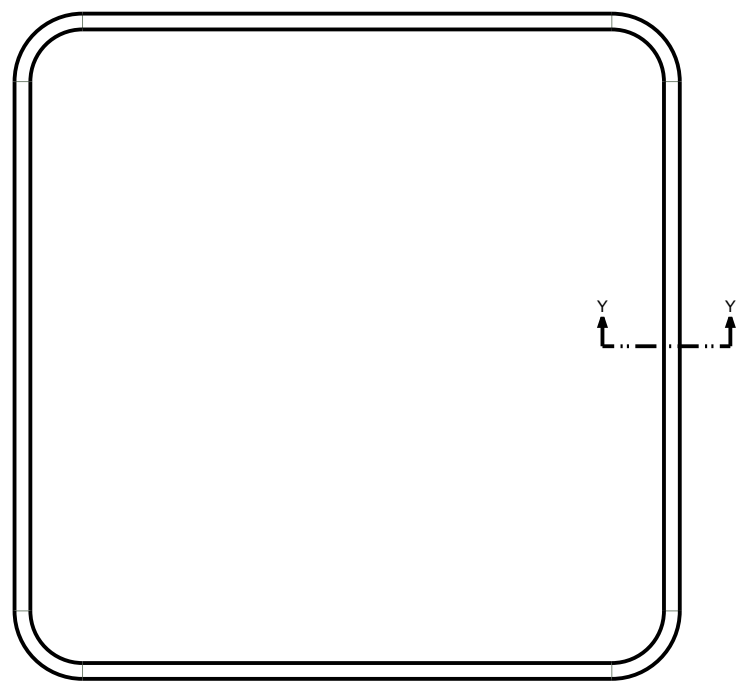

444414 FORMED O-RING
SCALE 0.800

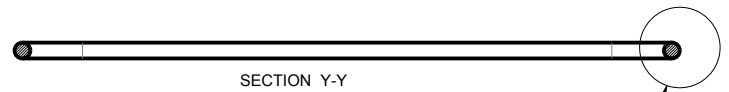

SECTION Y-Y

SEE DETAIL C

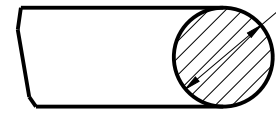

DETAIL C
SCALE 5.000

TOLERANCES: UNLESS OTHERWISE SPECIFIED
DIMENSIONS ARE IN U.S. INCHES.
X.XX = .015 X.XXXX = .001
X.XXX = .010 X.X° = 1°

NEW AGE ENCLOSURES
Customer's Part No: 444414

APPROVAL	BY	DATE
CHECK		
ENG.		
SCALE	AS NOTED	

DRAWN BY
M BOYER 2021-Apr-12

NEW AGE ENCLOSURES
2240 South Thornburg Street Santa Maria, CA. 93455
ph. (855) 462-3625 fax (805) 595-1024

www.newageenclosures.com

LARGE OUTDOOR NODE - STANDARD
SXL-444414-XXX

SIZE A	DRAWING NAME 444414_RG	SHEET 5 OF 7	REV.DOC G
-----------	---------------------------	-----------------	--------------

444414 PCB - CUSTOMER SUPPLIED

PCB SIZES ARE RECOMMENDATIONS ONLY. FINAL SIZES AND VERIFICATION OF ITS FIT ARE THE SOLE RESPONSIBILITY OF THE OEM.

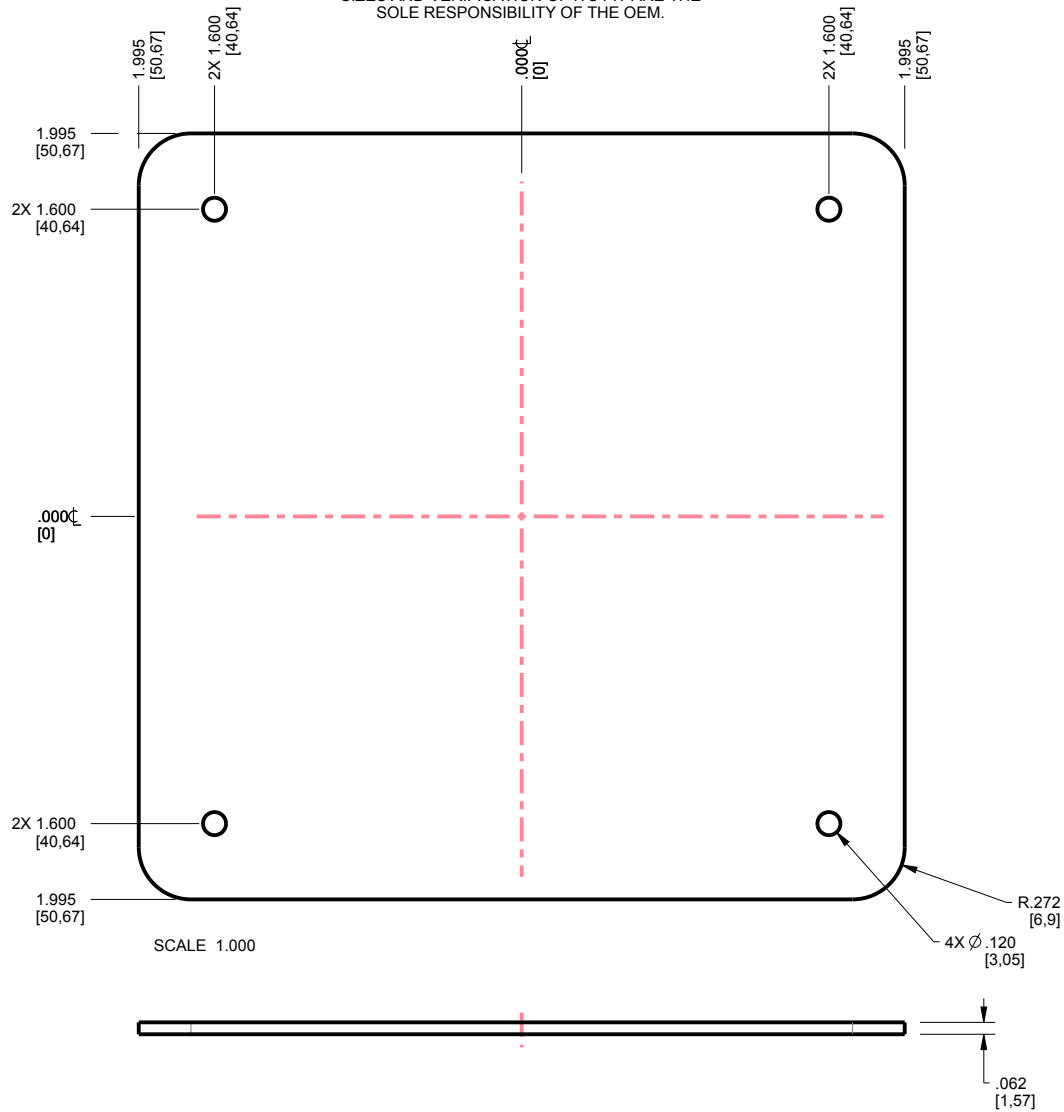

TOLERANCES: UNLESS OTHERWISE SPECIFIED
DIMENSIONS ARE IN U.S. INCHES.
X.XX = .015 X.XXXX = .001
X.XXX = .010 X.X° = 1°

NEW AGE ENCLOSURES

Customer's Part No: 444414

APPROVAL	BY	DATE
CHECK		
ENG.		
SCALE	AS NOTED	

DRAWN BY
M BOYER 2021-Apr-12

NEW AGE ENCLOSURES

2240 South Thornburg Street Santa Maria, CA. 93455
ph. (805) 595-1310 fax (805) 595-1024
www.newageenclosures.com

LARGE OUTDOOR NODE - STANDARD
SXL-444414-XXX

SIZE A	DRAWING NAME 444414_RG	SHEET 6 OF 7	REV.DOC G
-----------	---------------------------	-----------------	--------------

444414 - 2nd OPERATION DETAILS

NEW AGE ENCLOSURES DELIVERS YOUR ENCLOSURE MARKET-READY WITH IN-HOUSE
CNC MACHINING, PAD PRINTING, ASSEMBLY, AND FULFILLMENT.
ALL SURFACES AND AREAS ARE AVAILABLE FOR CNC ALTERATION BY NEW AGE ENCLOSURES
CALL (805) 595-1310 FOR PRICING AND SCHEDULE.
THE INSIDE RADIUS OF ANY MACHINED FEATURES SHOULD BE NO SMALLER THAN .031"

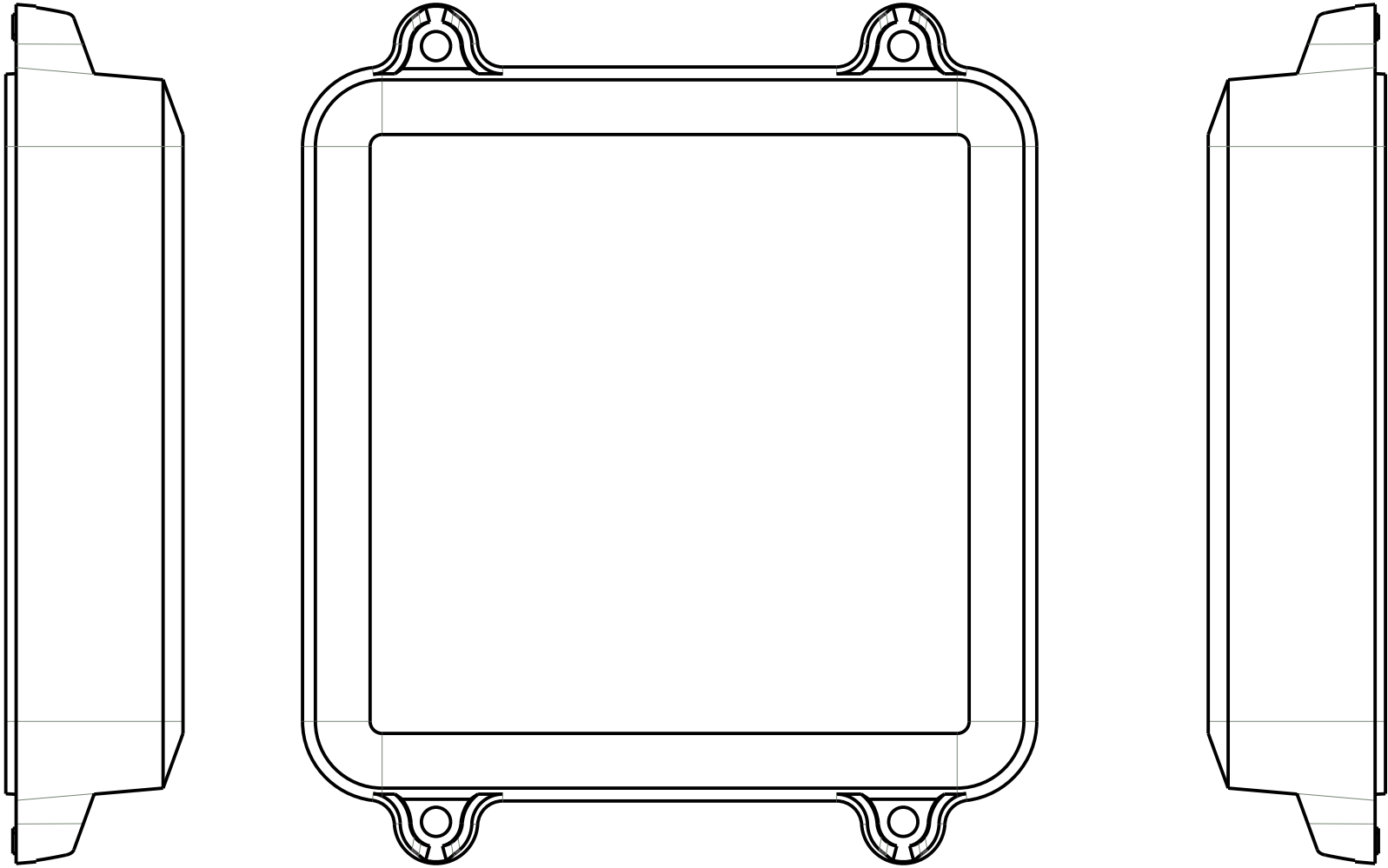

444414 COVER
SCALE 1.000

TOLERANCES: UNLESS OTHERWISE SPECIFIED
DIMENSIONS ARE IN U.S. INCHES.
X.XX = .015 X.XXXX = .001
X.XXX = .010 X.X° = 1°

NEW AGE ENCLOSURES

Customer's Part No: 444414

NEW AGE ENCLOSURES

2240 South Thornburg Street Santa Maria, CA. 93455
ph. (805) 595-1310 fax (805) 595-1024
www.newageenclosures.com

SXL-444414-XXX COVER - ASA, BLACK

STEP NO	DESCRIPTION	CUTTER	FIXTURE	ORIENTATION	PROGRAM
1-C-C1	-	T2 = .062" EM	-	-	-
2-C-C2	-	T2 = .062" EM	-	-	-

APPROVAL	BY	DATE
CHECK		
ENG.		
SCALE	AS NOTED	
DRAWN BY	2021-Apr-12	
M BOYER		

**LARGE OUTDOOR NODE - STANDARD
SXL-444414-XXX**

SIZE	DRAWING NAME	SHEET	REV.DOC
A	444414_RG	7 OF 7	G

X-ON Electronics

Largest Supplier of Electrical and Electronic Components

Click to view similar products for [Enclosures for Industrial Automation](#) *category:*

Click to view products by [New Age](#) *manufacturer:*

Other Similar products are found below :

[116-508](#) [130-008](#) [190-005](#) [2202307](#) [2901699](#) [2790318](#) [WM011RI,BK](#) [WM052I,GY](#) [WM093RI,BK](#) [5030266](#) [WM053R,BK](#) [WM032I,BK](#)
[2909989](#) [120-908](#) [150-007](#) [790-207](#) [2200095](#) [111-012](#) [127-408](#) [802-407](#) [115-401](#) [795-001](#) [790-211](#) [733-820](#) [BW67DBKCSYL](#)
[CX68DBKANG](#) [CXL68DBKAYL](#) [CXL65DBKANG](#) [BW68DBKCSBL](#) [DPH-28714-C](#) [135-007](#) [721-032](#) [1103440](#) [1037322](#) [1167159](#)
[1158978](#) [1158981](#) [1158982](#) [2202667](#) [1017444](#) [BWA-AH664](#) [100-403-91](#) [100-405-01](#) [101-003-91](#) [101-004-91](#) [101-506-01](#) [WM012I,GY](#)
[WM013I,AL](#) [WM052RI,GY](#) [WM093RI,GY](#)