

From Off-The-Shelf to Market-Ready© New Age Enclosures is your Single Source Solution.
Let us quote modifying our Stock Enclosures to meet your end-use.
visit newageenclosures.com/services or call 855-4NA-ENCL today.

CNC CUTOUTS
PART DECORATING
CUSTOM COLOR AND MATERIAL
RF/EMI SHEILDING
CUSTOM TOOL INSERTS
CUSTOM ENCLOSURES AND DESIGN

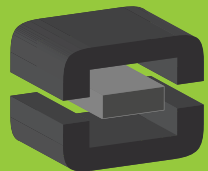

NEW AGE
ENCLOSURES

DEVELOP THE FUTURE



NOTES: UNLESS OTHERWISE SPECIFIED

- CORNERS DRAWN SHARP TO BE R.005 MAXIMUM.
- EXTERIOR SURFACE TEXTURE TO BE LIGHT EDM FINISH. EQUIVELANT TO MT-11020. CENTER PART TO BE POLISHED.
- INTERIOR SURFACE TEXTURE TO BE: NONE.
- ALL INSIDE RADII .010R. UNLESS OTHERWISE SPECIFIED.
- ALL EXTERNAL DIMENSIONS AFFECTED BY THE DRAFT APPLY AT THE LARGE END OF THE FEATURE, AND ALL INTERNAL FEATURES AFFECTED BY THE DRAFT APPLY AT THE SMALL END OF THE FEATURE UNLESS OTHERWISE SPECIFIED.
- 1 DEGREE DRAFT IN THE DIRECTION OF PULL IS PERMISSIBLE UNLESS OTHERWISE SPECIFIED.
- ASSEMBLY SCREWS FOR THE ENCLOSURE ARE INCLUDED. MOUNTING SCREWS FOR THE PCB AND WALL ARE SOLD SEPERATELY.
- MATERIAL / COLOR: ENCLOSURE IN ASA PLASTIC IS STANDARD IN BLACK OR GREY. SLIGHT COSMETIC SWIRLING, BLUSHING, AND/OR DISCOLORATION CAN OCCUR IN THIS ENCLOSURE DUE TO UV INHIBITORS IN THE RESIN. O-RING IN TPE IS STANDARD IN BLUE. CUSTOM MATERIALS AND COLORS ARE AVAILABLE UPON REQUEST FOR QUOTE.
- PCB SIZES ARE RECOMMENDATIONS ONLY. FINAL SIZES AND VERIFICATION OF ITS FIT ARE THE SOLE RESPONSIBILITY OF OEM.
- THIS ENCLOSURE IS CONSTRUCTED FOR INDOOR OR OUTDOOR USE TO PROVIDE A DEGREE OF PROTECTION TO THE EQUIPMENT INSIDE AGAINST THE INGRESS OF SOLID FOREIGN OBJECTS (FALLING DIRT); AND TO PROVIDE A DEGREE OF PROTECTION WITH RESPECT TO TO HARMFUL EFFECTS ON THE EQUIPMENT DUE TO THE INGRESS OF WATER (DRIPPING OR SPLASHING).

REVISION

REV.	DRAWN BY	ECO No	DESCRIPTION	DATE	APPROVED
A	M BOYER		PRELIMINARY RELEASE	2010-Sep-17	D.C.
J	M BOYER		REMOVE SHOWN USB CUTOUT	27-Jan-12	D.C.
1.0	M BOYER		UPDATE TO AS-BUILT AND RELEASED TO MFG	23-May-12	D.C.
1.1	M BOYER	2612	REVISE STANDARD B.O.M. & INSERT SHEET 3	26-Jul-12	D.C.
2.0	R CRUZ	8513	UPDATE CONFIGURATION TABLE TO INCLUDE O-RINGS WITH ENCLOSURE	30-Dec-13	D.C.
2.1	R CRUZ	0414	UPDATE CONFIG TABLE - REMOVE BATTERY O-RING FROM -Sx CONFIGS	24-Jan-14	D.C.
2.2	M BOYER	1314	REVISE INSERT SIZE ON BOM	29-May-14	D.C.
3.0	M BOYER	1514	INCREASE ORING THICKNESS	02-Jul-14	D.C.
3.1	R CRUZ	02115	UPDATE NOTE 8	20-May-15	D.C.
4.0	R CRUZ	03115	CHANGED O-RING COLOR FROM NATURAL TO BLUE	07-Jul-15	D.C.
4.1	M BOYER	02516	INCLUDE NOTE 10	2016-May-04	D.C.
5.0	M BOYER	01718	CHANGE ORING TO BE OFF-THE-SHELF OR EQUIV.	2018-Jun-19	

452715(x) CONFIGURATIONS				
	-SW	-BS	-SS	-BW
452715 BATTERY COVER		1		1
452715 COVER (w/o BATTERY)	1		1	
452715 BASE		1	1	
452715 WALL BASE	1			1
452715 HATCH		1		1
6-32 PHILLIPS HEAD SCREW x .500"	4	4	4	4
8-32 PHILLIPS HEAD SCREW x .500"		2		2
6-32 x .281" OVERMOLD BRASS INSERT	4		4	
6-32 x .625" OVERMOLD BRASS INSERT		4		4
MAIN SEAL O-RING	1	1	1	1
BATTERY COMPARTMENT O-RING		1		1

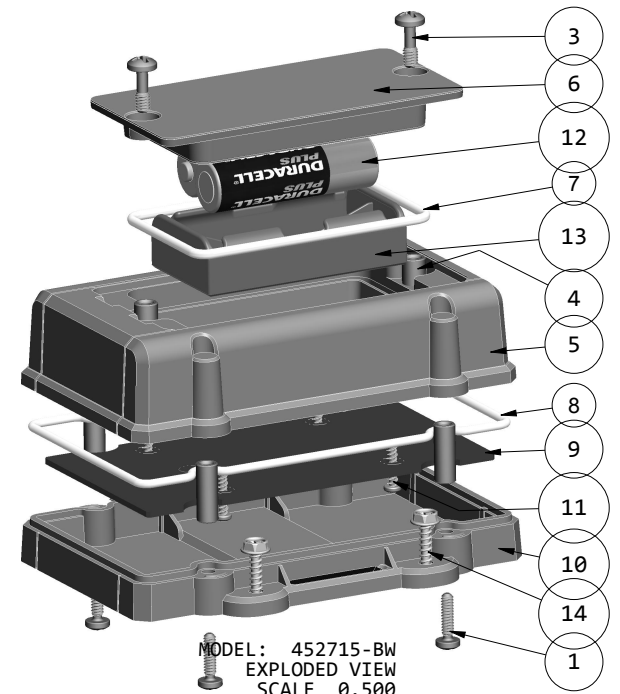
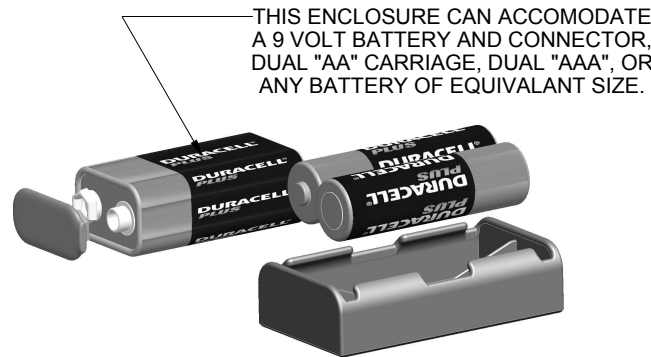

MODEL: 452715-BW
EXPLODED VIEW
SCALE 0.500

14	No6 SHEET METAL SCREW x 1.00"	410 STAINLESS	CUSTOMER SUPPLIED	4
13	BATTERY CARRIAGE AA - REFERENCE	KEYST # 2463	CUSTOMER SUPPLIED	1
12	AA BATTERY - REFERENCE	"AA" BATTERY SIZE	CUSTOMER SUPPLIED	2
11	#4 HiLo x .250" SCREW	ZINK PLATED	SOLD SEPERATELY	4
10	452715 WALL BASE - STANDARD	ASA	BLACK or GRAY	1
9	452715 PCB - REFERENCE	.062" THICK	CUSTOMER SUPPLIED	1
8	452715 O-RING, MAIN SEAL	OR-156 or EQUIV.	INCLUDED	1
7	452715 O-RING, BATT COMP	OTS	INCLUDED	1
6	452715 HATCH - STANDARD	ASA	BLACK or GRAY	1
5	452715 BATTERY COVER - STANDARD	ASA	BLACK or GRAY	1
4	8-32 x .344" CLOSED-END INSERT	TRISTAR 832X344MC	OVER-MOLDED BRASS	2
3	8-32 SCREW x .500	STAINLESS STEEL - PHILLIPS	.375" LONG	2
2	6-32 x .625" INSERT	TRISTAR 632X625C	OVER-MOLDED BRASS	4
1	6-32 SCREW x .500	STAINLESS STEEL - PHILLIPS	.500" LONG	4
ITEM	DESCRIPTION	MATERIAL	COLOR	QTY.

BILL OF MATERIALS - Wall Base & Battery Cover
(See Sheet 3 for Standard Cover and Standard Base)

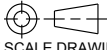
THIRD ANGLE PROJECTION  DO NOT SCALE DRAWING	TOLERANCES: UNLESS OTHERWISE SPECIFIED DIMENSIONS ARE IN U.S. INCHES. X.XX = .015 X.XXXX = .001 X.XXX = .010 X.X" = 1"	NEW AGE ENCLOSURES 2240 South Thornburg Street Santa Maria, CA. 93455 ph. (805) 595-1310 fax (805) 595-1024 www.newageenclosures.com
	Customer's Part No: 452715	
APPROVAL	BY DATE	INDUSTRIAL UTILITY - STANDARD SXL-452715X-XXX
CHECK		
ENG.		
SCALE	AS NOTED	
DRAWN BY M BOYER	2010-Sep-17	SIZE A
		DRAWING NAME 452715_R5_0
		SHEET 1 OF 12
		REV.DOC 5.0

452715-BW ASSEMBLY
COVER w/ BATTERY - WALL BASE

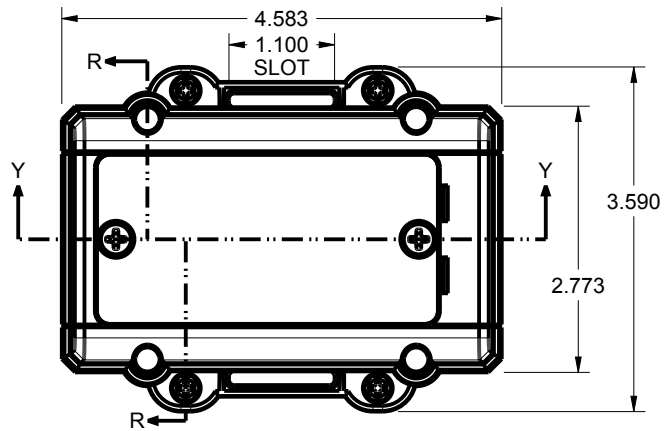

ASSEMBLY VIEW: 452715-BW
SCALE 0.500

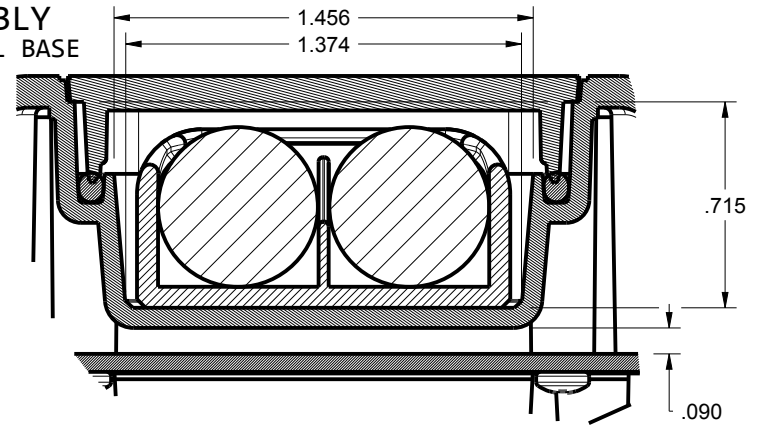

DETAIL C: 452715-BW
SCALE 1.500

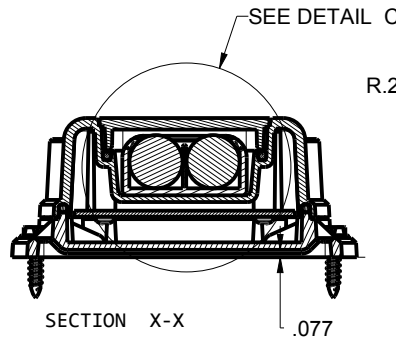
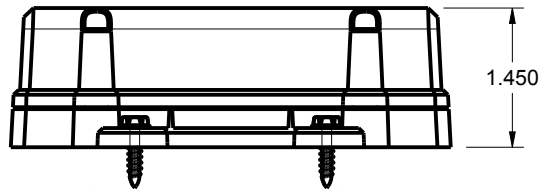

SECTION X-X

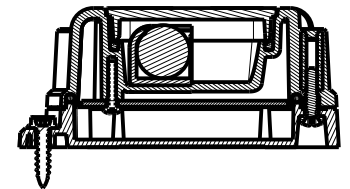
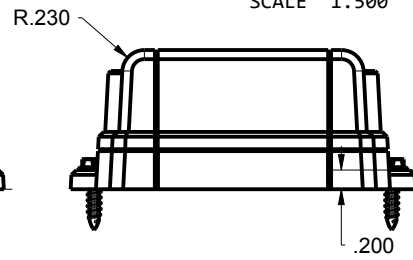

SECTION R-R

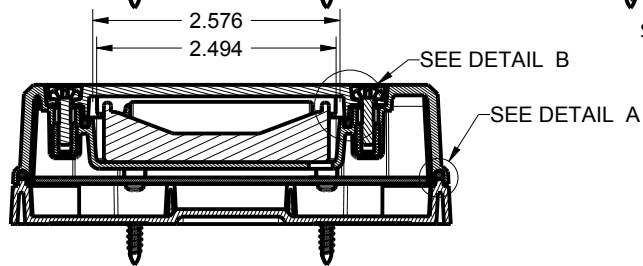

SECTION Y-Y

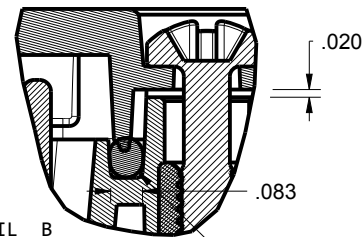

DETAIL B
SCALE 2.000

CENTER TO BE POLISHED

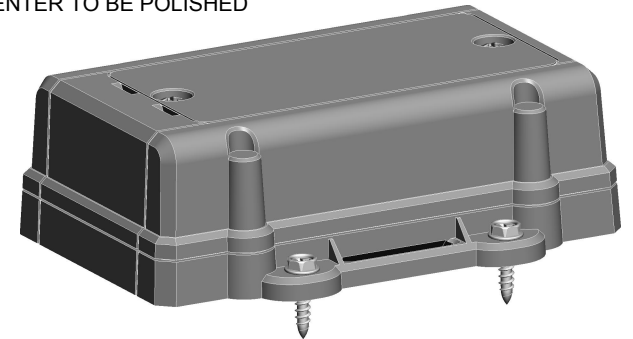

ISO VIEW: 452715-BW
SCALE 0.600

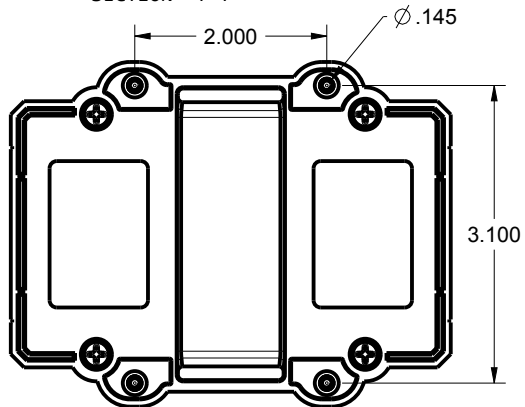

DETAIL A
SCALE 4.000

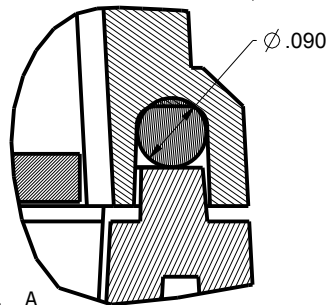

TOLERANCES: UNLESS OTHERWISE SPECIFIED
DIMENSIONS ARE IN U.S. INCHES.

X.XX = .015 X.XXXX = .001
X.XXX = .010 X.X° = 1°

NEW AGE ENCLOSURES
2240 South Thornburg Street Santa Maria, CA. 93455
ph. (805) 595-1310 fax (805) 595-1024

Customer's Part No: 452715

www.newageenclosures.com

APPROVAL	BY	DATE
CHECK		
ENG.		
SCALE	AS NOTED	

INDUSTRIAL UTILITY - STANDARD
SXL-452715X-XXX

DRAWN BY
M BOYER 2010-Sep-17

SIZE A
DRAWING NAME 452715_R5_0

SHEET 2 OF 12
REV.DOC 5.0

452715-SS ASSEMBLY

STANDARD COVER - STANDARD BASE

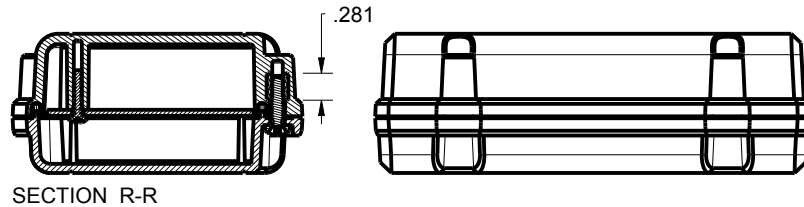
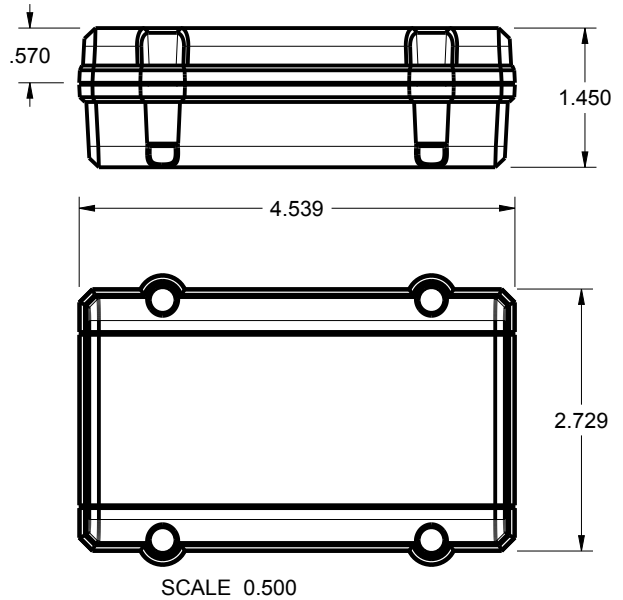
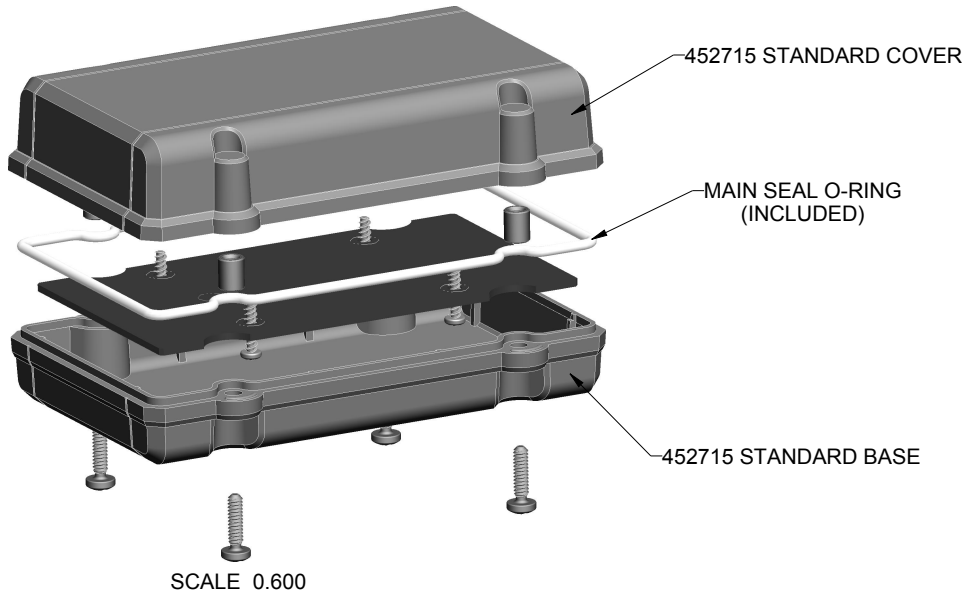

452715(x) CONFIGURATIONS				
	-SW	-BS	-SS	-BW
452715 BATTERY COVER		1		1
452715 COVER (w/o BATTERY)	1		1	
452715 BASE		1	1	
452715 WALL BASE	1			1
452715 HATCH		1		1
6-32 PHILLIPS HEAD SCREW x .500"	4	4	4	4
8-32 PHILLIPS HEAD SCREW x .500"		2		2
6-32 x .281" OVERMOLD BRASS INSERT	4		4	
6-32 x .625" OVERMOLD BRASS INSERT		4		4
MAIN SEAL O-RING	1	1	1	1
BATTERY COMPARTMENT O-RING		1		1

ITEM	DESCRIPTION	MATERIAL	COLOR	QTY.
7	#4 HiLo x .250" SCREW	ZINK PLATED	SOLD SEPERATELY	4
6	452715 PCB - REFERENCE	.062" THICK	CUSTOMER SUPPLIED	1
5	452715 O-RING, MAIN SEAL	OR-156 or EQUIV.	INCLUDED	1
4	452715 COVER - STANDARD	ASA	BLACK or GRAY	1
3	452715 BASE - STANDARD	ASA	BLACK or GRAY	1
2	6-32 x .281" INSERT	832X281C	OVER-MOLDED BRASS	4
1	6-32 SCREW x .500	STAINLESS STEEL - PHILLIPS	.500" LONG	4

BILL OF MATERIALS - Standard Base & Standard Cover
(See Sheet 1 for Battery Cover and Wall Base)

TOLERANCES: UNLESS OTHERWISE SPECIFIED
DIMENSIONS ARE IN U.S. INCHES.
X.XX = .015 X.XXXX = .001
X.XXX = .010 X.X" = 1°

NEW AGE ENCLOSURES
Customer's Part No: 452715

APPROVAL BY DATE
CHECK
ENG.
SCALE AS NOTED

DRAWN BY M BOYER
2010-Sep-17

NEW AGE ENCLOSURES
2240 South Thornburg Street Santa Maria, CA. 93455
ph. (805) 595-1310 fax (805) 595-1024
www.newageenclosures.com

INDUSTRIAL UTILITY - STANDARD SXL-452715X-XXX

SIZE A DRAWING NAME 452715_R5_0 SHEET 3 OF 12 REV.DOC 5.0

452715-SS ASSEMBLY
COVER - BASE

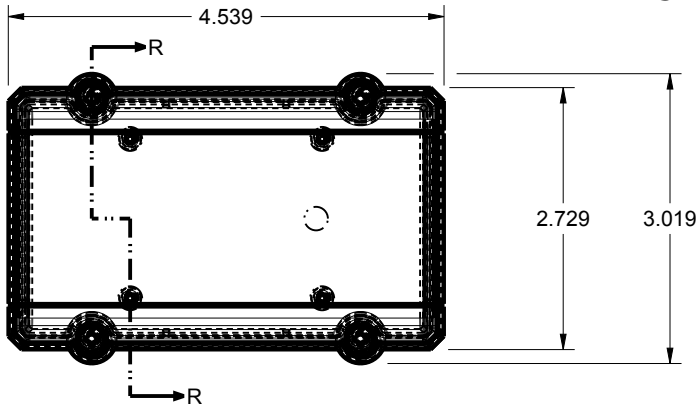

ASSEMBLY VIEW: 452715-SS
SCALE 0.500

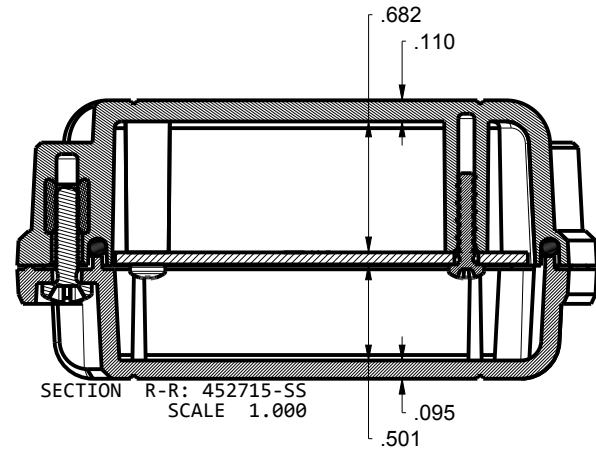

SECTION R-R: 452715-SS
SCALE 1.000

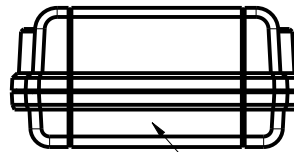
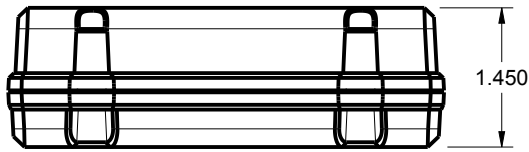

CENTER SECTION
TO BE POLISHED

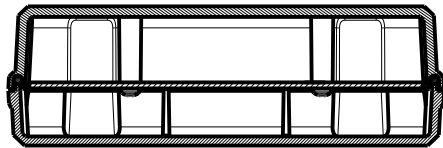

SECTION Y-Y

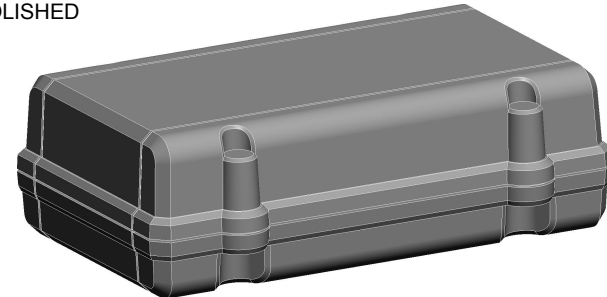

ISO VIEW: 452715-SS
SCALE 0.600

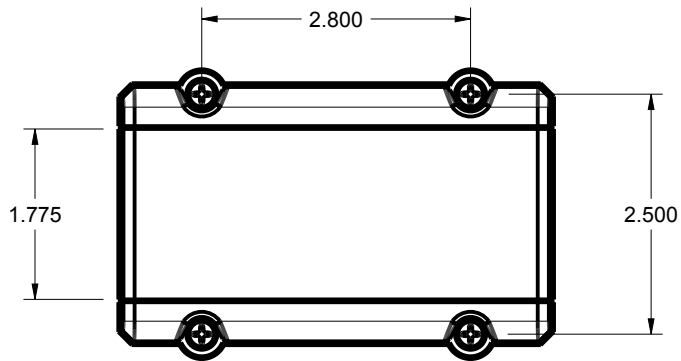

TOLERANCES: UNLESS OTHERWISE SPECIFIED
DIMENSIONS ARE IN U.S. INCHES.
X.XX = .015 X.XXXX = .001
X.XXX = .010 X.X° = 1°

NEW AGE ENCLOSURES
Customer's Part No: 452715

APPROVAL	BY	DATE
CHECK		
ENG.		
SCALE	AS NOTED	

DRAWN BY	2010-Sep-17
M BOYER	

NEW AGE ENCLOSURES
2240 South Thornburg Street Santa Maria, CA. 93455
ph. (805) 595-1310 fax (805) 595-1024
www.newageenclosures.com

INDUSTRIAL UTILITY - STANDARD
SXL-452715X-XXX

SIZE	DRAWING NAME
A	452715_R5_0

SHEET	REV.DOC
4 OF 12	5.0

452715 BATTERY COVER
FOR USE IN CONFIG: -BS -BW

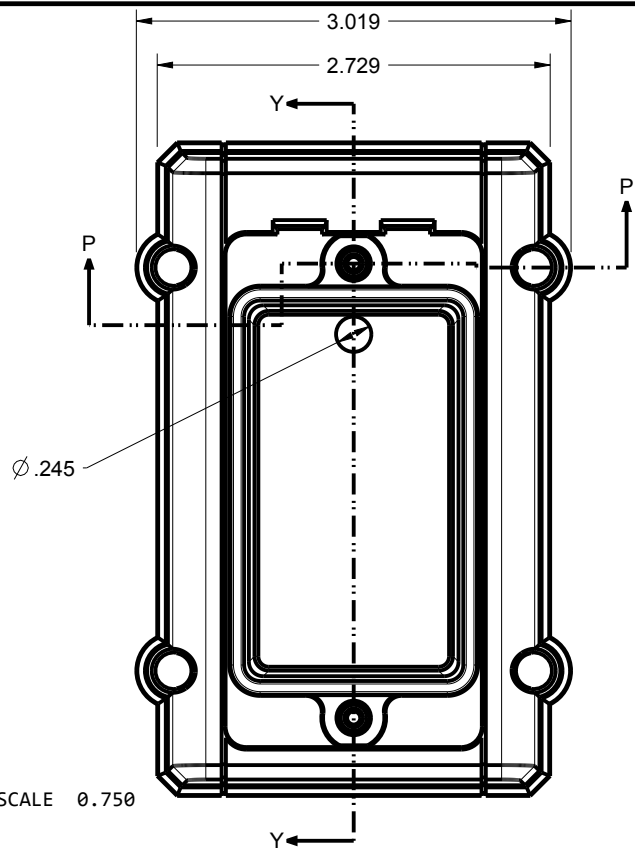

SCALE 0.750

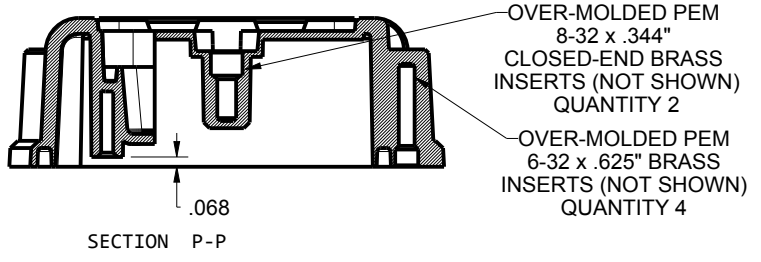
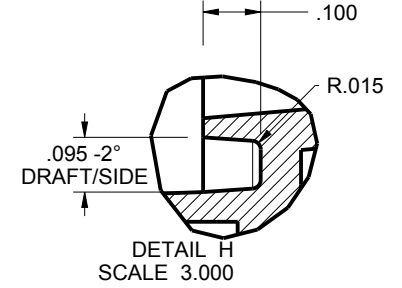
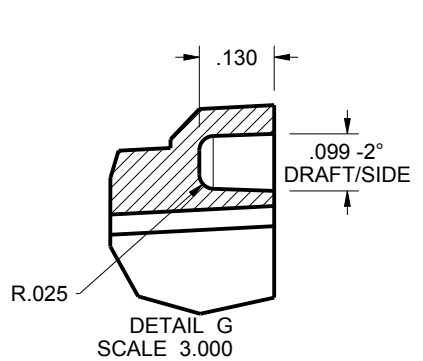
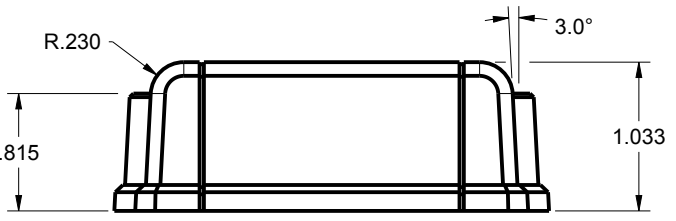
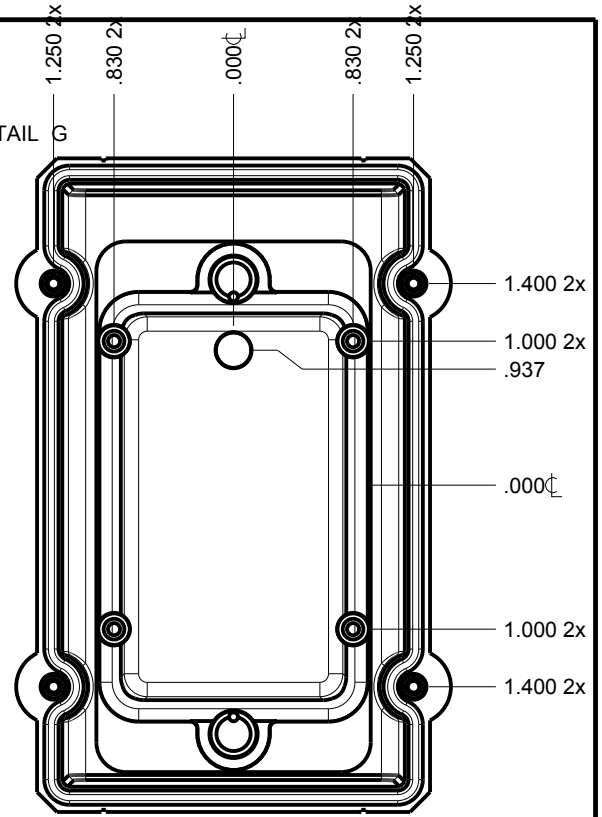
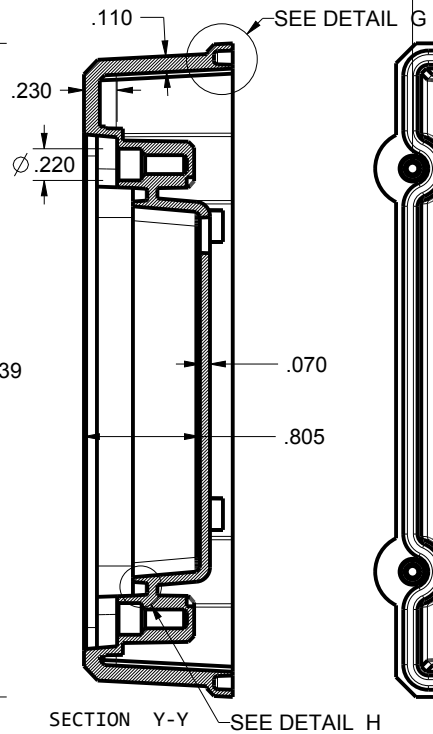
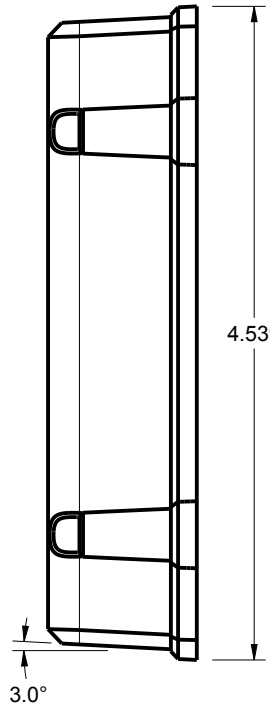

TOLERANCES: UNLESS OTHERWISE SPECIFIED DIMENSIONS ARE IN U.S. INCHES.
 X.XX = .015 X.XXXX = .001
 X.XXX = .010 X.X° = 1°

NEW AGE ENCLOSURES
 Customer's Part No: 452715

APPROVAL	BY	DATE
CHECK		
ENG.		
SCALE	AS NOTED	
DRAWN BY	M BOYER	
	2010-Sep-17	

NEW AGE ENCLOSURES
 2240 South Thornburg Street Santa Maria, CA. 93455
 ph. (805) 595-1310 fax (805) 595-1024
www.newageenclosures.com

INDUSTRIAL UTILITY - STANDARD
 SXL-452715X-XXX

SIZE	DRAWING NAME	SHEET	REV.DOC
A	452715_R5_0	5 OF 12	5.0

452715 COVER
FOR USE IN CONFIG: -SW -SS

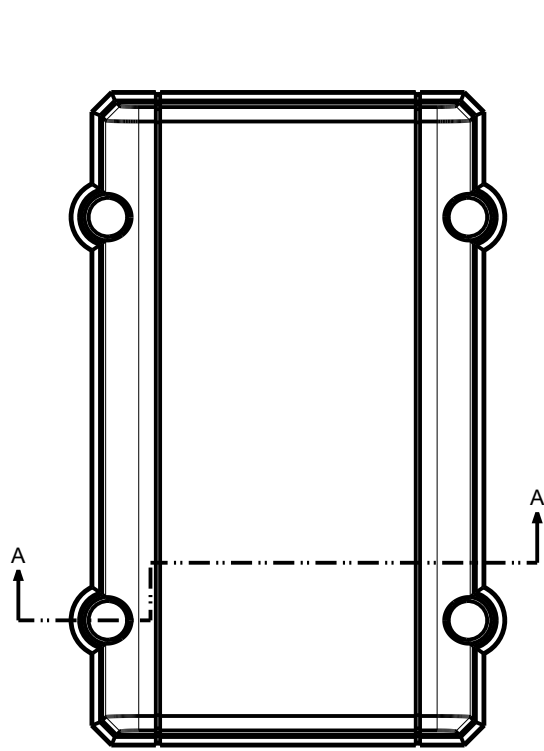

SCALE ϕ .750

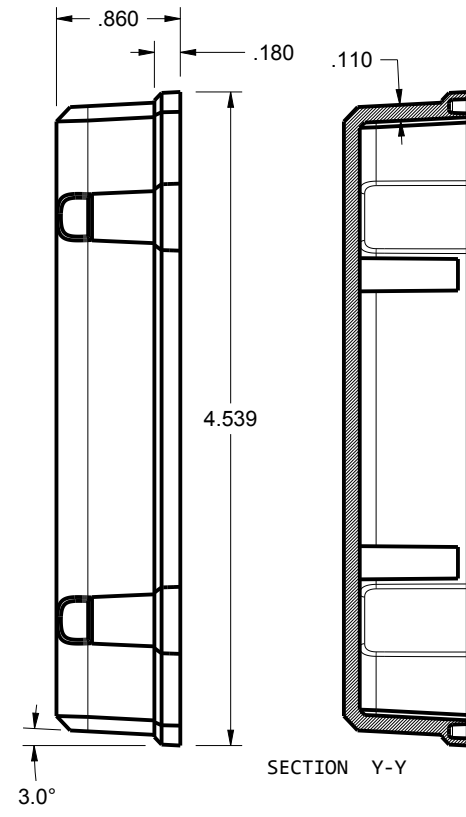

SECTION Y-Y

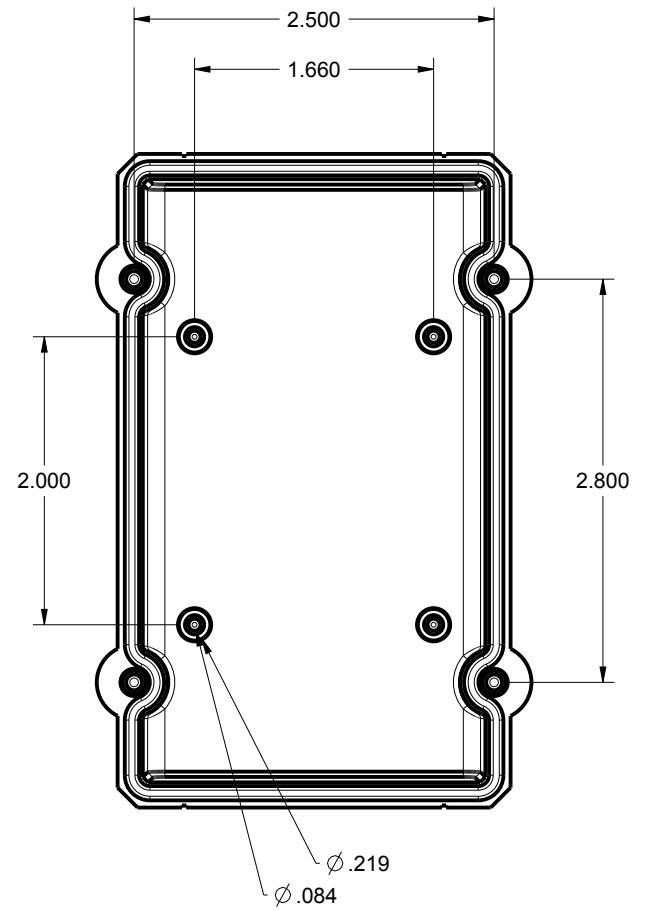

OVER-MOLDED PEM
6-32 x .281" BRASS
INSERTS (NOT SHOWN)
QUANTITY 4

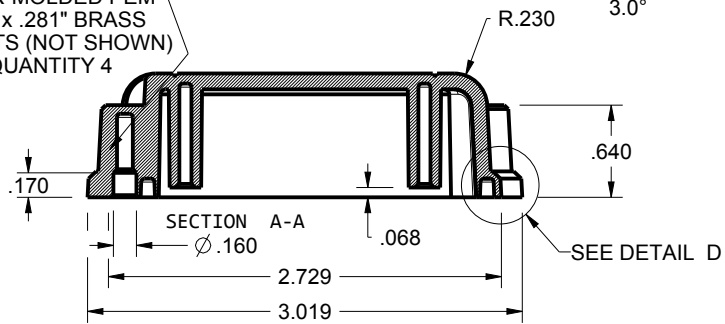

SECTION A-A

SEE DETAIL D

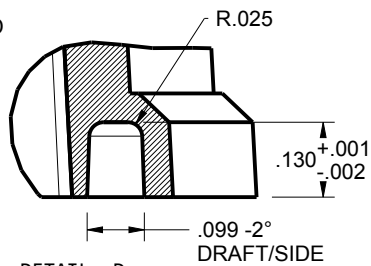

DETAIL D
SCALE 3.000



TOLERANCES: UNLESS OTHERWISE SPECIFIED
DIMENSIONS ARE IN U.S. INCHES.
X.XX = .015 X.XXXX = .001
X.XXX = .010 X.X' = 1°

NEW AGE ENCLOSURES
Customer's Part No: 452715

APPROVAL	BY	DATE
CHECK		
ENG.		
SCALE	AS NOTED	

NEW AGE ENCLOSURES
2240 South Thornburg Street Santa Maria, CA. 93455
ph. (805) 595-1310 fax (805) 595-1024
www.newageenclosures.com

INDUSTRIAL UTILITY - STANDARD
SXL-452715X-XXX

DRAWN BY
M BOYER 2010-Sep-17

SIZE
A 452715_R5_0

SHEET
6 OF 12

REV.DOC
5.0

452715 WALL BASE
FOR USE IN CONFIG: -SW -BW

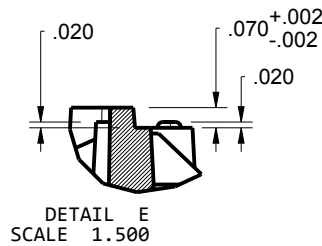
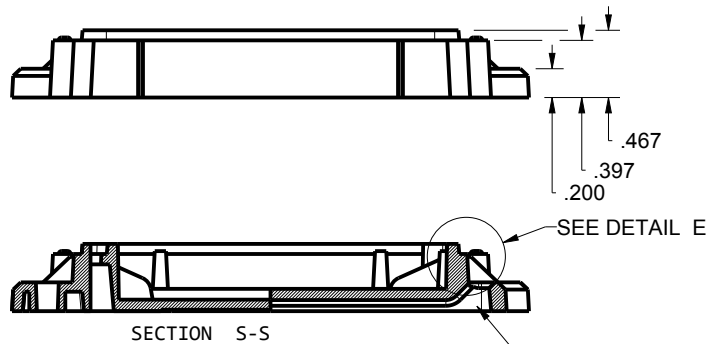
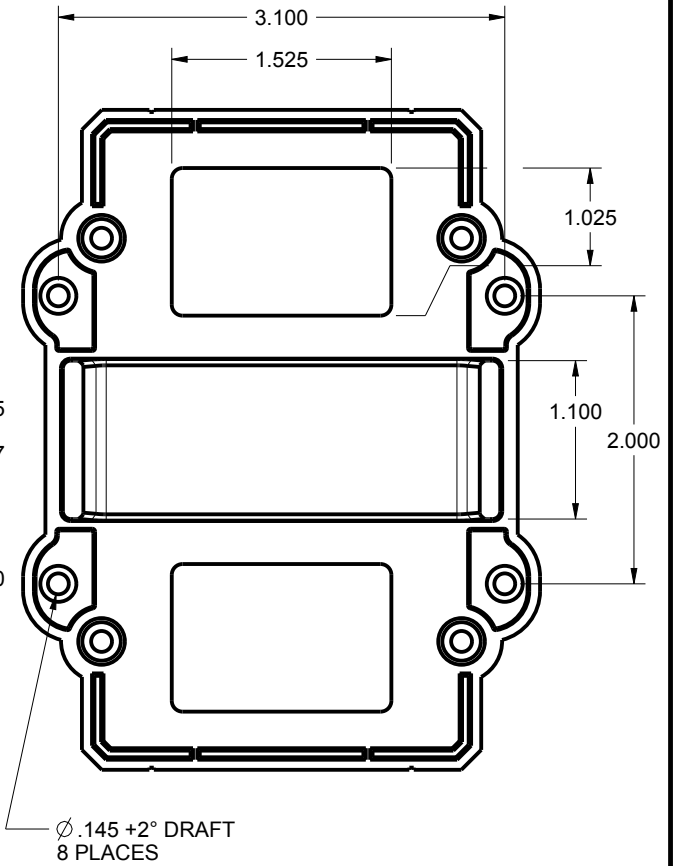
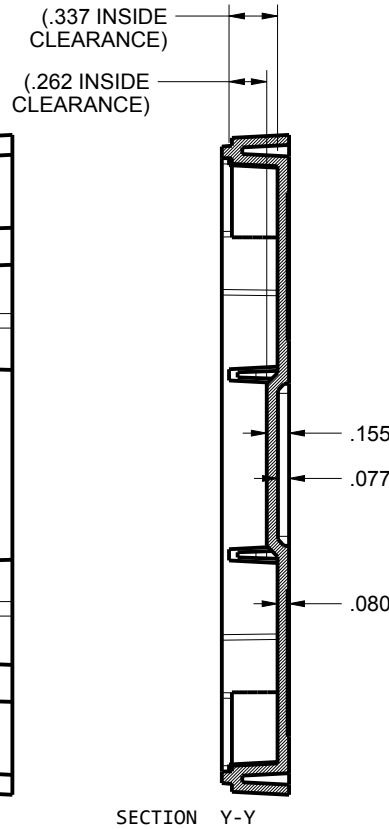
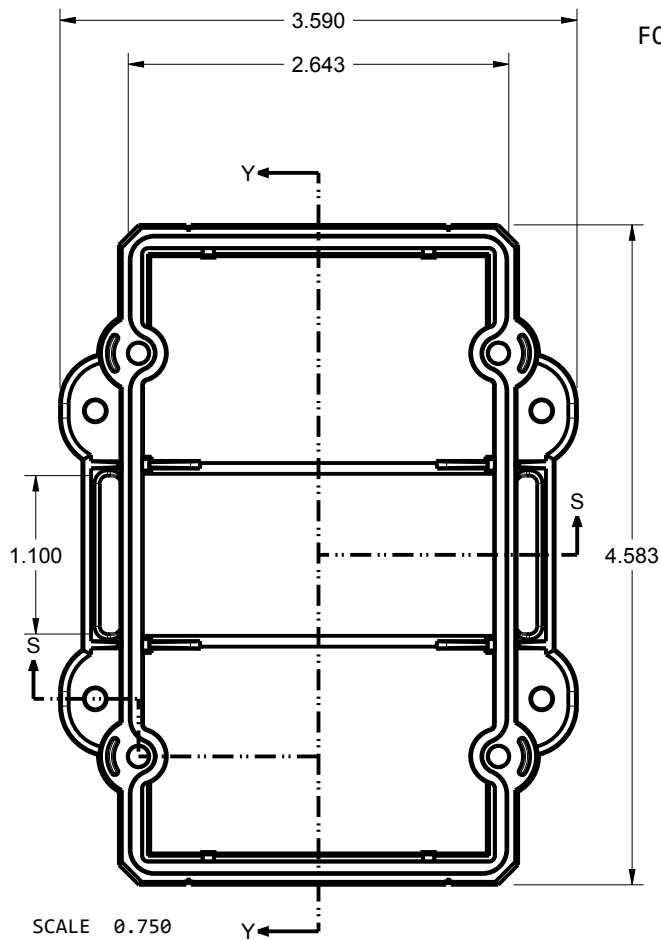

OPENING FOR STRAP

TOLERANCES: UNLESS OTHERWISE SPECIFIED
DIMENSIONS ARE IN U.S. INCHES.

X.XX = .015 X.XXXX = .001
X.XXX = .010 X.X° = 1°

NEW AGE ENCLOSURES

Customer's Part No: 452715

APPROVAL BY DATE

CHECK

ENG.

SCALE AS NOTED

DRAWN BY M BOYER 2010-Sep-17

NEW AGE ENCLOSURES

2240 South Thornburg Street Santa Maria, CA. 93455
ph. (805) 595-1310 fax (805) 595-1024
www.newageenclosures.com

INDUSTRIAL UTILITY - STANDARD
SXL-452715X-XXX

SIZE A DRAWING NAME 452715_R5_0

SHEET 7 OF 12 REV.DOC 5.0

452715 BASE
FOR USE IN CONFIG: -SS -BS

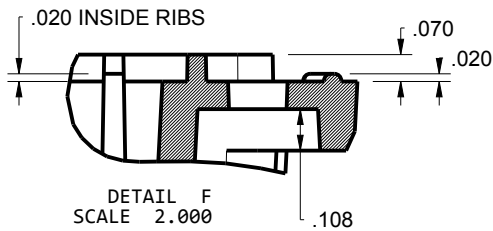
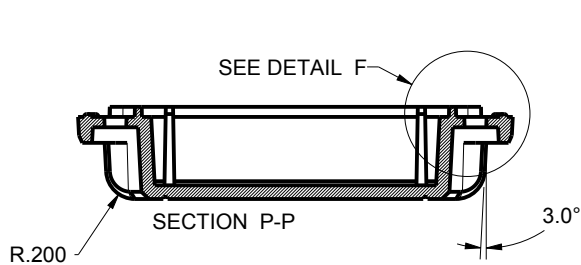
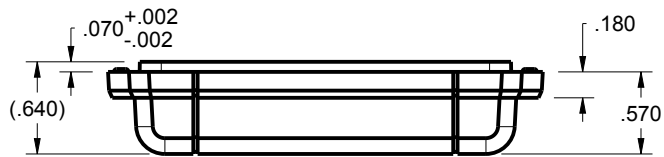
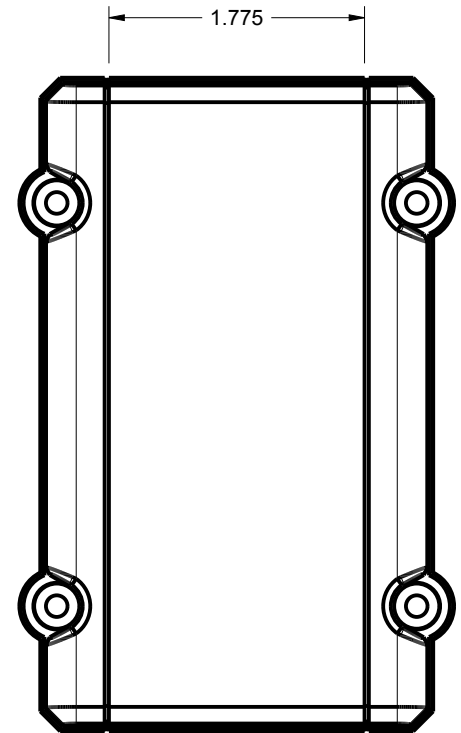
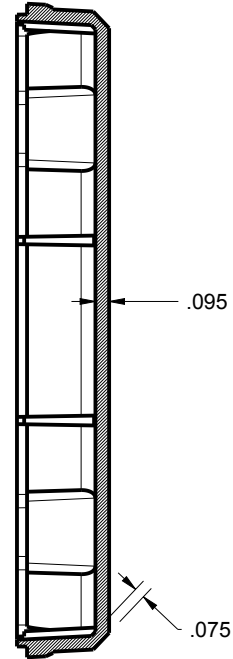
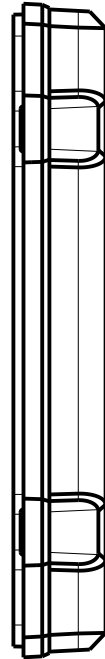
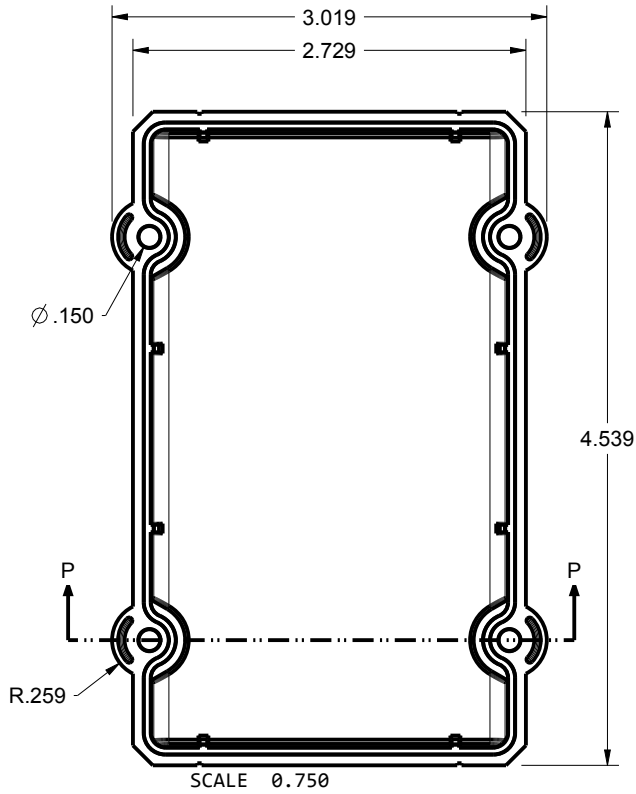

TOLERANCES: UNLESS OTHERWISE SPECIFIED
DIMENSIONS ARE IN U.S. INCHES.

X.XX = .015 X.XXXX = .001
X.XXX = .010 X.X° = 1°

NEW AGE ENCLOSURES

Customer's Part No: 452715

APPROVAL BY DATE

CHECK

ENG.

SCALE AS NOTED

DRAWN BY M BOYER 2010-Sep-17

NEW AGE ENCLOSURES

2240 South Thornburg Street Santa Maria, CA. 93455
ph. (805) 595-1310 fax (805) 595-1024
www.newageenclosures.com

INDUSTRIAL UTILITY - STANDARD
SXL-452715X-XXX

SIZE A DRAWING NAME 452715_R5_0

SHEET 8 OF 12 REV.DOC 5.0

452715 HATCH
 FOR USE IN CONFIG: -BS -BW

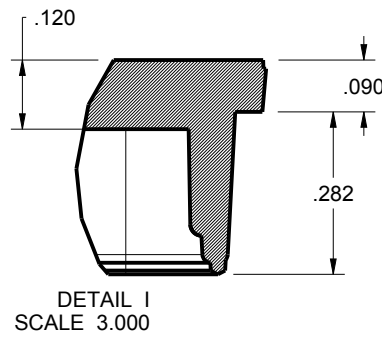
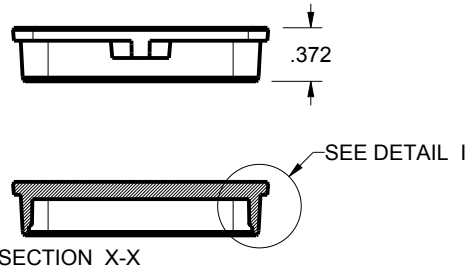
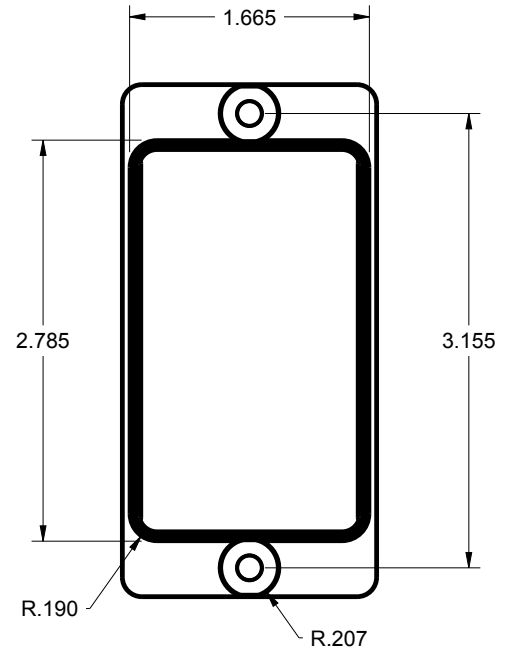
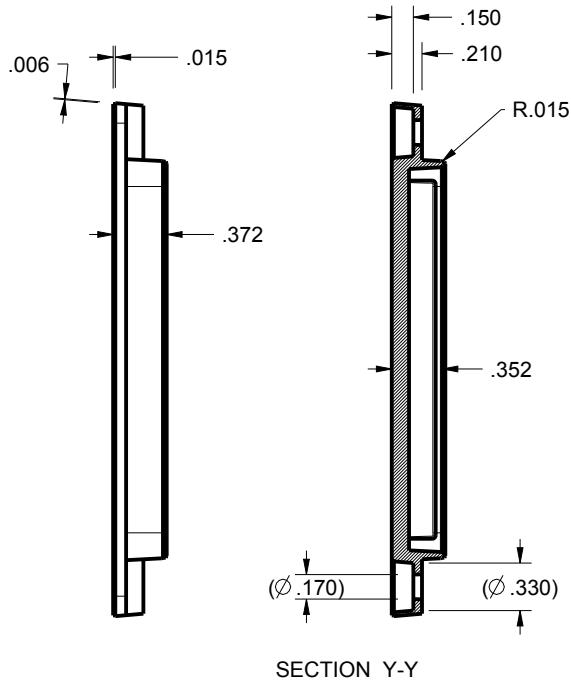
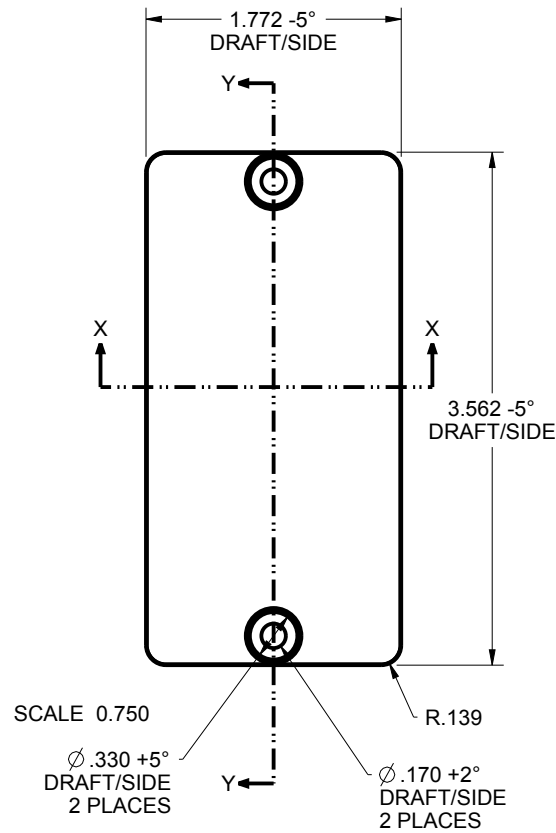

TOLERANCES: UNLESS OTHERWISE SPECIFIED DIMENSIONS ARE IN U.S. INCHES. X.XX = .015 X.XXXX = .001 X.XXX = .010 X.X° = 1°		NEW AGE ENCLOSURES	
NEW AGE ENCLOSURES		2240 South Thornburg Street Santa Maria, CA. 93455 ph. (805) 595-1310 fax (805) 595-1024 www.newageenclosures.com	
Customer's Part No: 452715			
APPROVAL	BY	DATE	
CHECK			
ENG.			
SCALE	AS NOTED		
DRAWN BY	SIZE	DRAWING NAME	SHEET
M BOYER	2010-Sep-17	A 452715_R5_0	9 OF 12
			REV.DOC
			5.0

452715 MAIN O-RING
FOR USE IN ALL CONFIGURATIONS

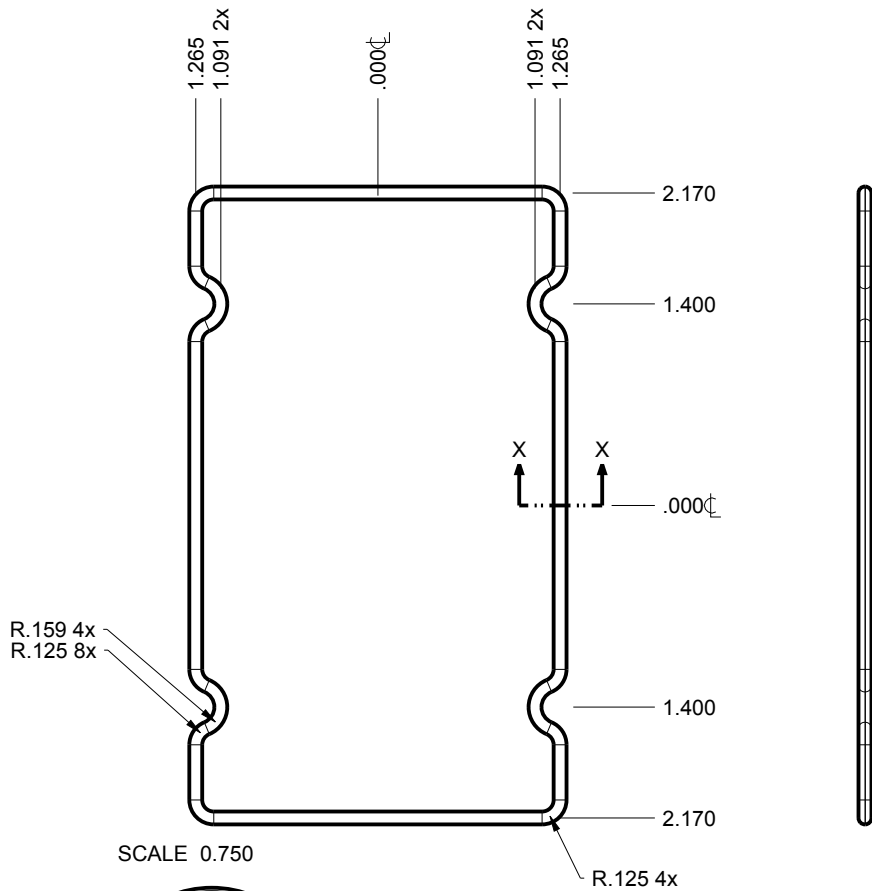

SCALE 0.750

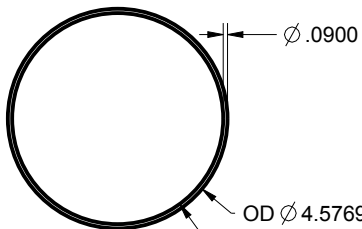

OR-156 or EQUIV.
SCALE 0.250

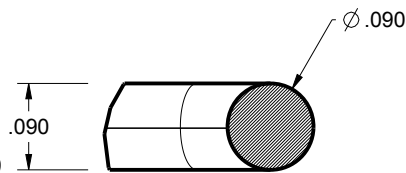

SECTION X-X
SCALE 5.000

452715 BATTERY O-RING
FOR USE IN CONFIG: -BS -BW

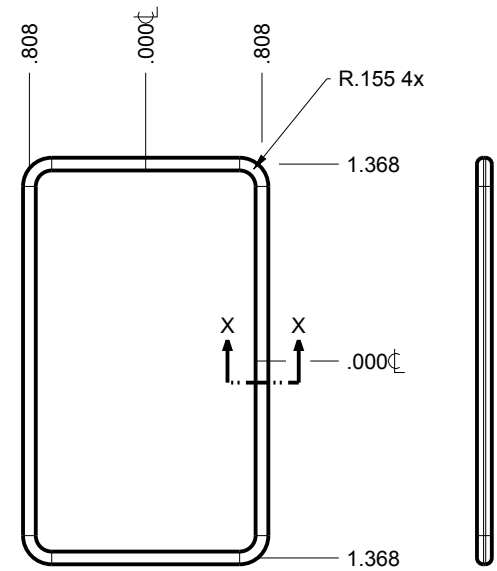

SCALE 0.750

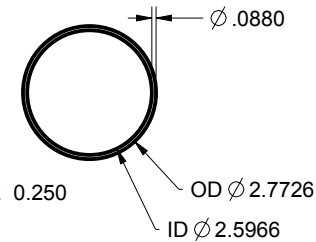

SCALE 0.250

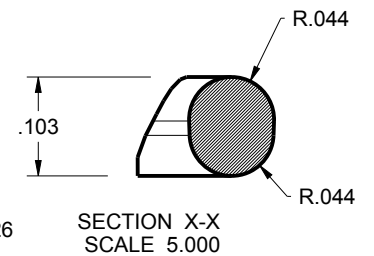

SECTION X-X
SCALE 5.000

TOLERANCES: UNLESS OTHERWISE SPECIFIED
DIMENSIONS ARE IN U.S. INCHES.
X.XX = .015 X.XXXX = .001
X.XXX = .010 X.X° = 1°

NEW AGE ENCLOSURES
Customer's Part No: 452715

APPROVAL BY DATE

CHECK

ENG.

SCALE AS NOTED

DRAWN BY M BOYER 2010-Sep-17

NEW AGE ENCLOSURES

2240 South Thornburg Street Santa Maria, CA. 93455
ph. (805) 595-1310 fax (805) 595-1024
www.newageenclosures.com

INDUSTRIAL UTILITY - STANDARD
SXL-452715X-XXX

SIZE A DRAWING NAME 452715_R5_0

SHEET 10 OF 12 REV.DOC 5.0

452715 PCB - Customer Supplied

PCB SIZES ARE RECOMMENDATIONS ONLY. FINAL SIZES AND VERIFICATION OF ITS FIT ARE THE SOLE RESPONSIBILITY OF THE OEM.

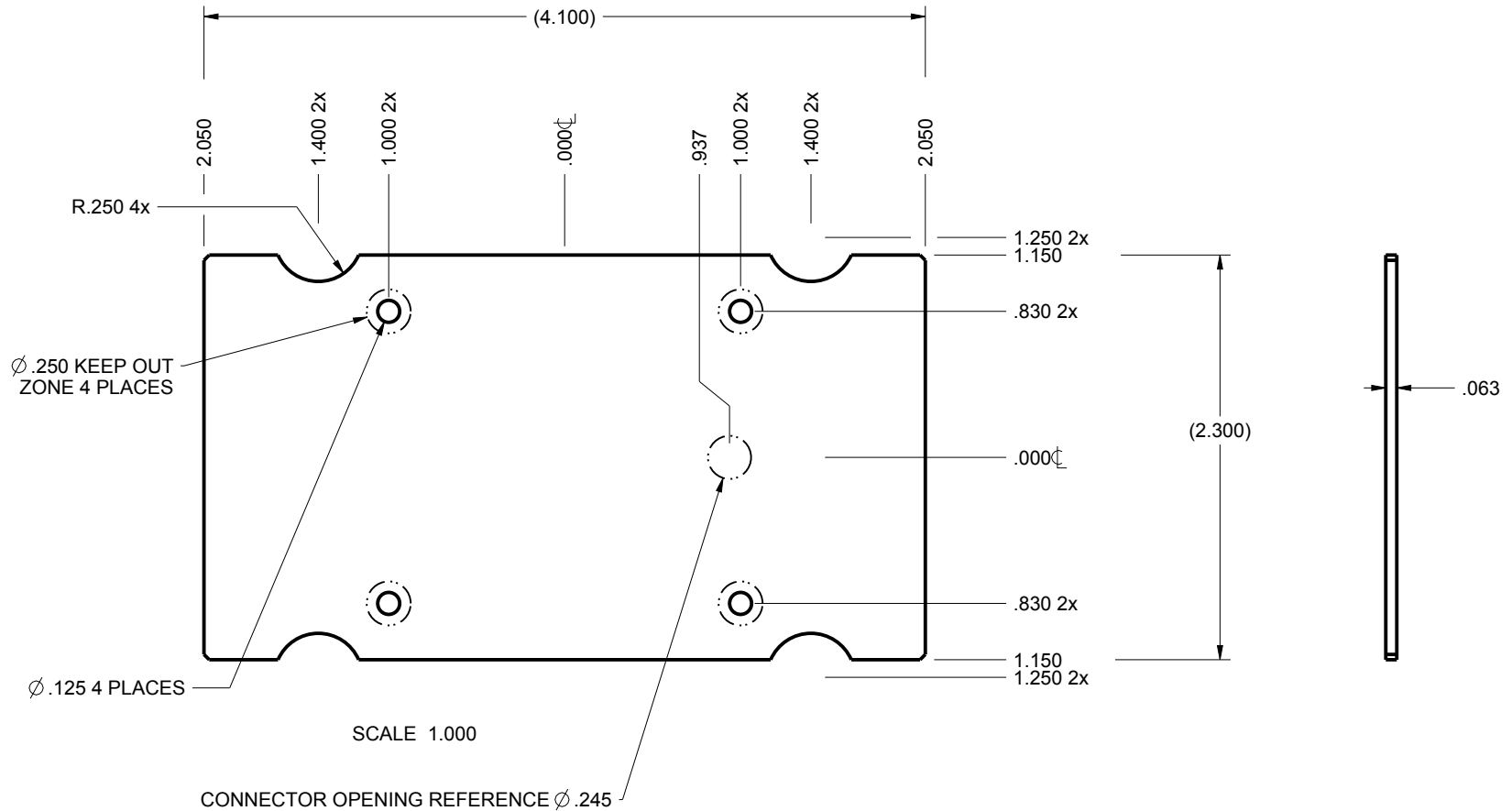

TOLERANCES: UNLESS OTHERWISE SPECIFIED
DIMENSIONS ARE IN U.S. INCHES.
 X.XX = .015 X.XXXX = .001
 X.XXX = .010 X.X° = 1°

NEW AGE ENCLOSURES

Customer's Part No: 452715

APPROVAL	BY	DATE
CHECK		
ENG.		
SCALE	AS NOTED	

DRAWN BY	2010-Sep-17
M BOYER	

NEW AGE ENCLOSURES

2240 South Thornburg Street Santa Maria, CA. 93455
 ph. (805) 595-1310 fax (805) 595-1024
www.newageenclosures.com

INDUSTRIAL UTILITY - STANDARD
 SXL-452715X-XXX

SIZE	DRAWING NAME
A	452715_R5_0

SHEET	REV.DOC
11 OF 12	5.0

452715 2nd OPERATION DETAILS

NEW AGE ENCLOSURES DELIVERS YOUR ENCLOSURE MARKET-READY WITH IN-HOUSE
CNC MACHINING, PAD PRINTING, ASSEMBLY, AND FULFILLMENT.
ALL SURFACES AND AREAS ARE AVAILABLE FOR CNC ALTERATION BY NEW AGE ENCLOSURES
CALL (805) 595-1310 FOR PRICING AND SCHEDULE.
THE INSIDE RADIUS OF ANY MACHINED FEATURES SHOULD BE NO SMALLER THAN .031"

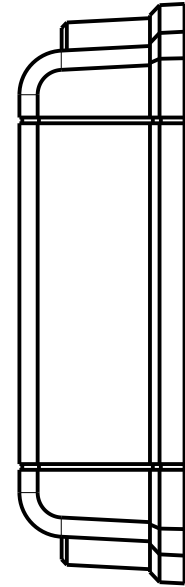
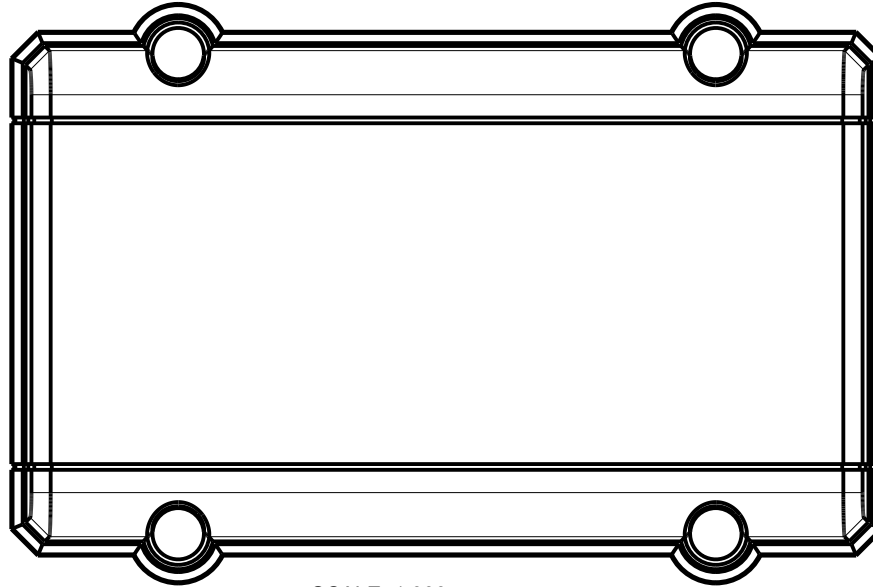
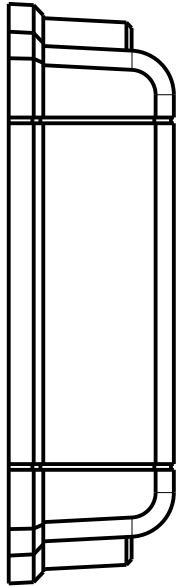

SCALE 1.000

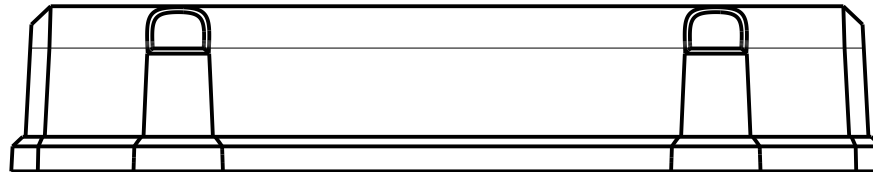

SXL-452715-XXX COVER - ASA, BLACK

STEP NO	DESCRIPTION	CUTTER	FIXTURE	ORIENTATION	PROGRAM
1-C-C1	-	T2 = .062" EM	266	-	o1000
2-C-C2	-	T2 = .062" EM	266	-	o1000
3-C-C3	-	T2 = .062" EM	266	-	o1000

TOLERANCES: UNLESS OTHERWISE SPECIFIED
DIMENSIONS ARE IN U.S. INCHES.
X.XX = .015 X.XXXX = .001
X.XXX = .010 X.X° = 1°

NEW AGE ENCLOSURES

Customer's Part No: 452715

NEW AGE
ENCLOSURES

2240 South Thornburg Street Santa Maria, CA. 93455
ph. (805) 595-1310 fax (805) 595-1024
www.newageenclosures.com

SXL-452715-XXX COVER - ASA, BLACK

STEP	TYPE	FIXTURE	INK COLOR	CLICHE DESCRIPTION	CLICHE No.
4-P-P1	PAD PRINT	267	-	-	CLxxxx R1

APPROVAL	BY	DATE
CHECK		
ENG.		
SCALE	AS NOTED	
DRAWN BY		
M BOYER	2010-Sep-17	

INDUSTRIAL UTILITY - STANDARD
SXL-452715X-XXX

SIZE	DRAWING NAME	SHEET	REV.DOC
A	452715_R5_0	12 OF 12	5.0

X-ON Electronics

Largest Supplier of Electrical and Electronic Components

Click to view similar products for [Enclosures, Boxes & Cases](#) *category:*

Click to view products by [New Age](#) *manufacturer:*

Other Similar products are found below :

[585-R-WH-PK](#) [M-10-PLATED](#) [60221-01](#) [60566-01-000](#) [HPL-9VB BATT DOOR](#) [M18-PLTD](#) [M-21-PLATED](#) [63310-01-000](#) [6711GSKT](#)
[71884-29-028](#) [LH45-100 Black](#) [72868-510-000](#) [CNS-0000 Black](#) [72883-510-000](#) [CNS-0101 Black](#) [72906-510-000](#) [CNS-0407 Black](#) [73092-](#)
[510-000](#) [CNM-0101 Black](#) [73105-510-000](#) [CNL-0101 Black](#) [73108-510-000](#) [CNL-0303 Black](#) [73395-510-039](#) [CNS-0006 Bone](#) [74257-510-000](#)
[CNL-0004](#) [MDC-1183-PLAIN-ALUM](#) [MDC-1183-PTD](#) [MDC-13104-PTD](#) [MDC-321-PTD](#) [MDC-973-PTD](#) [76](#) [77153-01-028](#) [FLX6030](#)
[83535-01-508](#) [90026-501-000](#) [PS36-200](#) [116-508](#) [120-407](#) [120-910](#) [127-908](#) [130-008](#) [1301170079](#) [1322GSKTEP](#) [1325GSKT3](#) [138-PLAIN](#)
[1434-1210](#) [EAS-500 \(BLACK ANO\)](#) [1804RP-RB-PK](#) [190-005](#) [2202307](#) [KAB3321 BLACK](#) [KAB3421](#) [2697466](#) [S52213](#) [2901123](#) [2901699](#)
[A0645271](#) [A20P20](#) [2106-IR](#)