

# NHD-0420E2Z-NSW-BBW

## Character Liquid Crystal Display Module

NHD- Newhaven Display  
0420- 4 Lines x 20 Characters  
E2Z- Model  
N- Transmissive  
SW- Side White LED Backlight  
B- STN Negative, Blue  
B- 6:00 Optimal View  
W- Wide Temperature  
**RoHS Compliant**

### Newhaven Display International, Inc.

2661 Galvin Ct.

Elgin IL, 60124

Ph: 847-844-8795

Fax: 847-844-8796

[www.newhavendisplay.com](http://www.newhavendisplay.com)

[nhtech@newhavendisplay.com](mailto:nhtech@newhavendisplay.com)

[nhsales@newhavendisplay.com](mailto:nhsales@newhavendisplay.com)

## Document Revision History

| Revision | Date     | Description  | Changed by |
|----------|----------|--|------------|
| 0        | 10/21/08 | Initial Release  | -          |
| 1        | 1/14/10  | User Guide Reformat                                    | MC         |
| 2        | 2/28/11  | Alternate controller information updated               | AK         |
| 3        | 5/6/11   | Electrical characteristics updated                     | AK         |
| 4        | 5/15/11  | Mechanical Drawing update                              | CL         |
| 5        | 12/21/16 | Mechanical Drawing, Optical & Electrical Char. Updated | SB         |
| 6        | 3/24/20  | Backlight, Optical & Electrical Char. Updated          | SB         |

## Functions and Features

- 4 lines x 20 characters
- Built-in controllers (ST7066U)
- +5.0V Power Supply
- 1/16 duty, 1/5 bias
- RoHS compliant

A

B

C

D

E

F

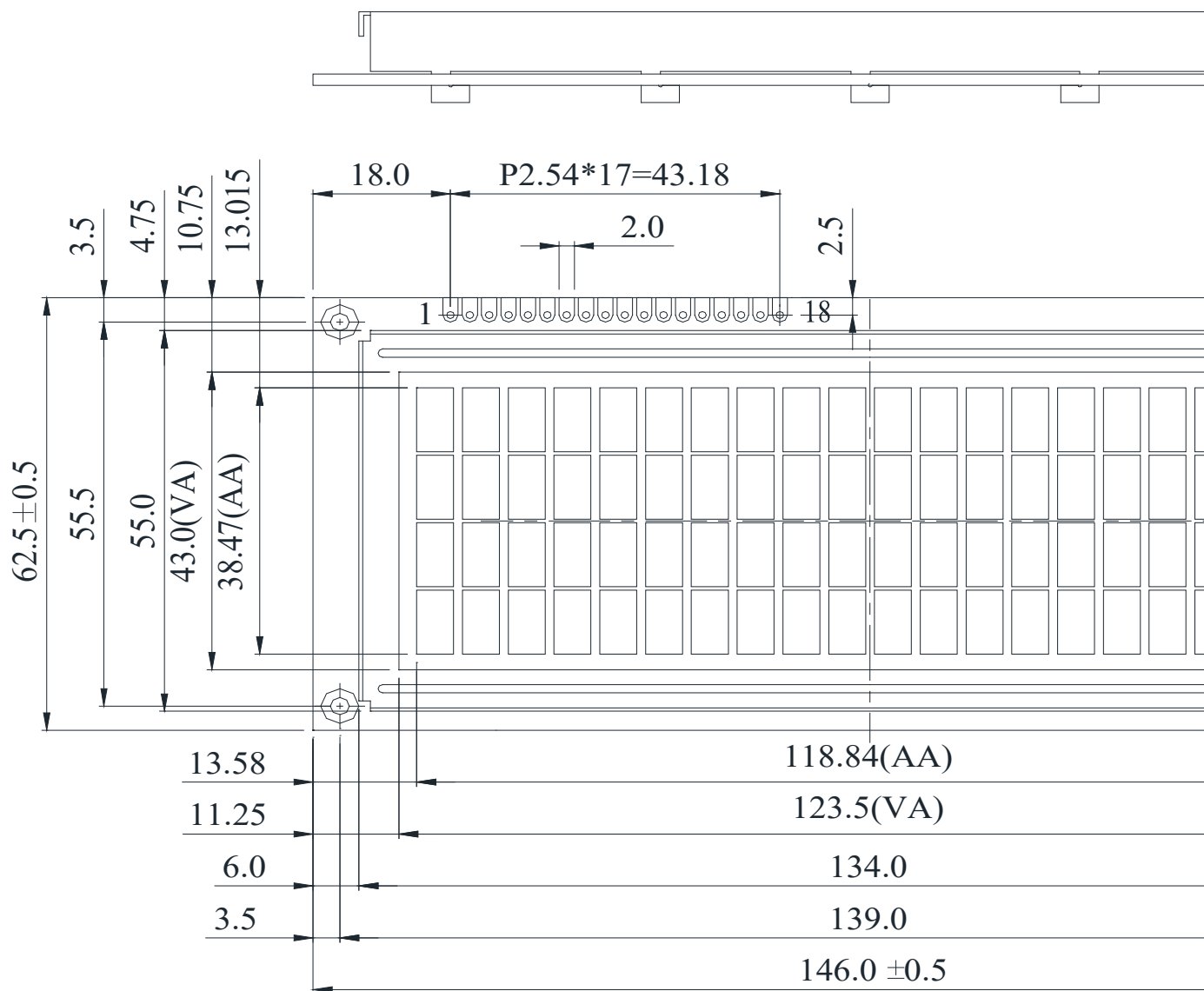

### Notes:

1. Driver: 1/16 Duty, 1/5 Bias
2. Voltage: 5.0V VDD, 4.2V VLCD
3. Display Mode: STN Negative / Blue / Transmissive
4. Optimal View: 6:00
5. Backlight: White LED
6. Driver IC: ST7066U 8/4-Bit MPU Interface

1

2

3

4

# Pin Description and Wiring Diagram

| Pin No. | Symbol          | External Connection | Function Description  |
|---------|-----------------|---------------------|---|
| 1       | V <sub>SS</sub> | Power Supply        | Ground  |
| 2       | V <sub>DD</sub> | Power Supply        | Supply Voltage for Logic (+5.0V)  |
| 3       | V <sub>0</sub>  | Power Supply        | Supply Voltage for Contrast (approx. 0.8V)  |
| 4       | RS              | MPU                 | Register Select signal. RS=0: Command, RS=1: Data   |
| 5       | R/W             | MPU                 | Read/Write select signal, R/W=1: Read R/W=0: Write  |
| 6       | E               | MPU                 | Operation Enable signal. Falling edge triggered.  |
| 7-10    | DB0-DB3         | MPU                 | For low order bi-directional three-state data bus lines. These four are no used during 4-bit operation. |
| 11-14   | DB4-DB7         | MPU                 | Four high order bi-directional three-state data bus lines.  |
| 15      | LED+            | Power Supply        | Backlight Anode (80 mA @ 5.0V)  |
| 16      | LED-            | Power Supply        | Backlight Cathode (Ground)  |

Recommended LCD connector: 2.54mm pitch pins

Backlight connector: --- Mates with: ---

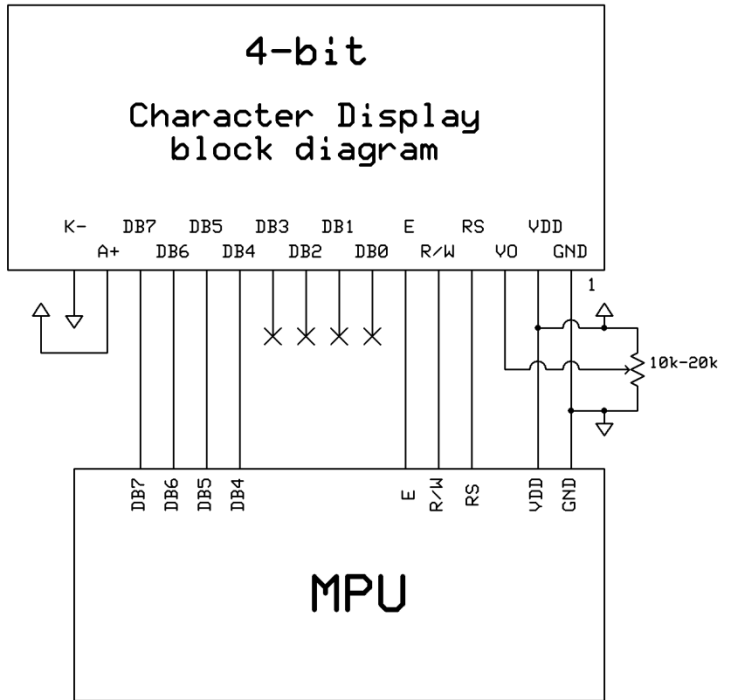
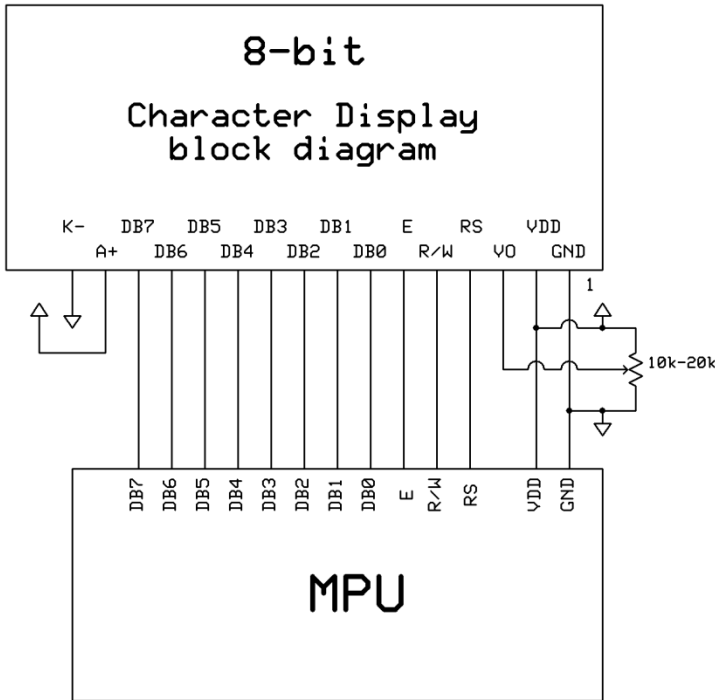

## Electrical Characteristics

| Item                        | Symbol           | Condition               | Min.                  | Typ. | Max.            | Unit |
|-----------------------------|------------------|-------------------------|-----------------------|------|-----------------|------|
| Operating Temperature Range | T <sub>OP</sub>  | Absolute Max            | -20                   | -    | +70             | °C   |
| Storage Temperature Range   | T <sub>ST</sub>  | Absolute Max            | -30                   | -    | +80             | °C   |
| Supply Voltage              | V <sub>DD</sub>  | -                       | 4.5                   | 5.0  | 5.5             | V    |
| Supply Current              | I <sub>DD</sub>  | V <sub>DD</sub> = 5.0V  | 0.4                   | 2.0  | 4.0             | mA   |
| Supply for LCD (contrast)   | V <sub>LCD</sub> | T <sub>OP</sub> = 25°C  | 4.0                   | 4.2  | 4.4             | V    |
| "H" Level input             | V <sub>IH</sub>  | -                       | 0.7 * V <sub>DD</sub> | -    | V <sub>DD</sub> | V    |
| "L" Level input             | V <sub>IL</sub>  | -                       | V <sub>SS</sub>       | -    | 0.6             | V    |
| "H" Level output            | V <sub>OH</sub>  | -                       | 3.9                   | -    | V <sub>DD</sub> | V    |
| "L" Level output            | V <sub>OL</sub>  | -                       | V <sub>SS</sub>       | -    | 0.4             | V    |
| Backlight Supply Voltage    | V <sub>LED</sub> | -                       | 4.9                   | 5.0  | 5.1             | V    |
| Backlight Supply Current    | I <sub>LED</sub> | V <sub>LED</sub> = 5.0V | 25                    | 80   | 100             | mA   |

## Optical Characteristics

| Item                   | Symbol | Condition              | Min. | Typ. | Max. | Unit |
|------------------------|--------|------------------------|------|------|------|------|
| Optimal Viewing Angles | Top    | CR ≥ 2                 | -    | 20   | -    | °    |
|                        | Bottom |                        | -    | 40   | -    | °    |
|                        | Left   |                        | -    | 30   | -    | °    |
|                        | Right  |                        | -    | 30   | -    | °    |
| Contrast Ratio         | CR     | -                      | 2    | 5    | -    | -    |
| Response Time          | Rise   | T <sub>OP</sub> = 25°C | -    | 150  | 200  | ms   |
|                        | Fall   |                        | -    | 150  | 200  | ms   |

## Controller Information

Built-in ST7066U Controller.

Please download specification at [http://www.newhavendisplay.com/app\\_notes/ST7066U.pdf](http://www.newhavendisplay.com/app_notes/ST7066U.pdf)

## DDRAM Address

| 1  | 2  | 3  | 4  | 5  | 6  | 7  | 8  | 9  | 10 | 11 | 12 | 13 | 14 | 15 | 16 | 17 | 18 | 19 | 20 |
|----|----|----|----|----|----|----|----|----|----|----|----|----|----|----|----|----|----|----|----|
| 00 | 01 | 02 | 03 | 04 | 05 | 06 | 07 | 08 | 09 | 0A | 0B | 0C | 0D | 0E | 0F | 10 | 11 | 12 | 13 |
| 40 | 41 | 42 | 43 | 44 | 45 | 46 | 47 | 48 | 49 | 4A | 4B | 4C | 4D | 4E | 4F | 50 | 51 | 52 | 53 |
| 14 | 15 | 16 | 17 | 18 | 19 | 1A | 1B | 1C | 1D | 1E | 1F | 20 | 21 | 22 | 23 | 24 | 25 | 26 | 27 |
| 54 | 55 | 56 | 57 | 58 | 59 | 5A | 5B | 5C | 5D | 5E | 5F | 60 | 61 | 62 | 63 | 64 | 65 | 66 | 67 |

## Table of Commands

| Instruction                | Instruction code |     |     |     |     |     |     |     |     |     | Description | Execution time (f <sub>osc</sub> =270 KHZ)   |        |
|----------------------------|------------------|-----|-----|-----|-----|-----|-----|-----|-----|-----|-------------|--|--------|
|                            | RS               | R/W | DB7 | DB6 | DB5 | DB4 | DB3 | DB2 | DB1 | DB0 |             |  |        |
| Clear Display              | 0                | 0   | 0   | 0   | 0   | 0   | 0   | 0   | 0   | 0   | 1           | Write "20H" to DDRAM and set DDRAM address to "00H" from AC  | 1.52ms |
| Return Home                | 0                | 0   | 0   | 0   | 0   | 0   | 0   | 0   | 0   | 1   | -           | Set DDRAM Address to "00H" from AC and return cursor to its original position if shifted. The contents of DDRAM are not changed. | 1.52ms |
| Entry mode Set             | 0                | 0   | 0   | 0   | 0   | 0   | 0   | 0   | 1   | I/D | SH          | Sets cursor move direction and specifies display shift. These parameters are performed during data write and read.               | 37μs   |
| Display ON/OFF control     | 0                | 0   | 0   | 0   | 0   | 0   | 0   | 1   | D   | C   | B           | D=1: Entire display on<br>C=1: Cursor on<br>B=1: Blinking cursor on  | 37μs   |
| Cursor or Display shift    | 0                | 0   | 0   | 0   | 0   | 0   | 1   | S/C | R/L | -   | -           | Sets cursor moving and display shift control bit, and the direction without changing DDRAM data.                                 | 37μs   |
| Function set               | 0                | 0   | 0   | 0   | 1   | DL  | N   | F   | -   | -   | -           | DL: Interface data is 8/4 bits<br>N: Number of lines is 2/1<br>F: Font size is 5x11/5x8  | 37μs   |
| Set CGRAM Address          | 0                | 0   | 0   | 1   | AC5 | AC4 | AC3 | AC2 | AC1 | AC0 |             | Set CGRAM address in address counter   | 37μs   |
| Set DDRAM Address          | 0                | 0   | 1   | AC6 | AC5 | AC4 | AC3 | AC2 | AC1 | AC0 |             | Set DDRAM address in address counter.  | 37μs   |
| Read busy Flag and Address | 0                | 1   | BF  | AC6 | AC5 | AC4 | AC3 | AC2 | AC1 | AC0 |             | Whether during internal operation or not can be known by reading BF. The contents of address counter can also be read.           | 0s     |
| Write data To Address      | 1                | 0   | D7  | D6  | D5  | D4  | D3  | D2  | D1  | D0  |             | Write data into internal RAM (DDRAM/CGRAM).  | 37μs   |
| Read data From RAM         | 1                | 1   | D7  | D6  | D5  | D4  | D3  | D2  | D1  | D0  |             | Read data from internal RAM (DDRAM/CGRAM).   | 37μs   |

# Timing Characteristics

## Writing data from MPU to ST7066U



| Write Mode (Writing data from MPU to ST7066U) |                       |                 |      |   |    |    |
|---|-----------------------|-----------------|------|---|----|----|
| $T_C$   | Enable Cycle Time     | Pin E           | 1200 | - | -  | ns |
| $T_{PW}$                                      | Enable Pulse Width    | Pin E           | 140  | - | -  | ns |
| $T_R, T_F$                                    | Enable Rise/Fall Time | Pin E           | -    | - | 25 | ns |
| $T_{AS}$                                      | Address Setup Time    | Pins: RS,RW,E   | 0    | - | -  | ns |
| $T_{AH}$                                      | Address Hold Time     | Pins: RS,RW,E   | 10   | - | -  | ns |
| $T_{DSW}$                                     | Data Setup Time       | Pins: DB0 - DB7 | 40   | - | -  | ns |
| $T_H$   | Data Hold Time        | Pins: DB0 - DB7 | 10   | - | -  | ns |

## Reading data from ST7066U to MPU



| Read Mode (Reading Data from ST7066U to MPU) |                       |                 |      |   |     |    |
|--|-----------------------|-----------------|------|---|-----|----|
| $T_C$  | Enable Cycle Time     | Pin E           | 1200 | - | -   | ns |
| $T_{PW}$                                     | Enable Pulse Width    | Pin E           | 140  | - | -   | ns |
| $T_{R}, T_F$                                 | Enable Rise/Fall Time | Pin E           | -    | - | 25  | ns |
| $T_{AS}$                                     | Address Setup Time    | Pins: RS, RW, E | 0    | - | -   | ns |
| $T_{AH}$                                     | Address Hold Time     | Pins: RS, RW, E | 10   | - | -   | ns |
| $T_{DDR}$                                    | Data Setup Time       | Pins: DB0 - DB7 | -    | - | 100 | ns |
| $T_H$  | Data Hold Time        | Pins: DB0 - DB7 | 10   | - | -   | ns |



# Built-in Font Table

| b7-b4<br>b3-b0 | 0000             | 0001 | 0010 | 0011 | 0100 | 0101 | 0110 | 0111 | 1000 | 1001 | 1010 | 1011 | 1100 | 1101 | 1110 | 1111 |
|----------------|------------------|------|------|------|------|------|------|------|------|------|------|------|------|------|------|------|
| 0000           | CG<br>RAM<br>(1) |      |      | 0    | a    | P    | ^    | F    |      |      |      | —    | 9    | 3    | o    | p    |
| 0001           | (2)              |      | !    | 1    | A    | Q    | a    | A    |      |      | a    | 7    | 7    | G    | ä    | g    |
| 0010           | (3)              |      | "    | 2    | B    | R    | b    | r    |      |      | "    | 4    | ウ    | ×    | B    | e    |
| 0011           | (4)              |      | #    | 3    | C    | S    | c    | s    |      |      | ∟    | ウ    | テ    | E    | ε    | ×    |
| 0100           | (5)              |      | *    | 4    | D    | T    | d    | t    |      |      | ∟    | 工    | ト    | ト    | μ    | a    |
| 0101           | (6)              |      | z    | 5    | E    | U    | e    | u    |      |      | *    | 才    | 大    | 1    | ε    | 0    |
| 0110           | (7)              |      | &    | 6    | F    | V    | f    | v    |      |      | ワ    | 力    | 二    | ヨ    | p    | Σ    |
| 0111           | (8)              |      | '    | 7    | G    | W    | g    | w    |      |      | フ    | 才    | 又    | ウ    | g    | π    |
| 1000           | (1)              |      | <    | 8    | H    | X    | h    | x    |      |      | イ    | ウ    | *    | リ    | フ    | ×    |
| 1001           | (2)              |      | >    | 9    | I    | Y    | i    | y    |      |      | o    | ウ    | ノ    | ル    | リ    | y    |
| 1010           | (3)              |      | *    | :    | J    | Z    | j    | z    |      |      | ε    | コ    | ∩    | ∟    | j    | ≠    |
| 1011           | (4)              |      | +    | :    | K    | L    | k    | l    |      |      | *    | ウ    | E    | 0    | ×    | π    |
| 1100           | (5)              |      | ,    | <    | L    | ∞    | l    | l    |      |      | ト    | 9    | ウ    | ウ    | o    | π    |
| 1101           | (6)              |      | —    | =    | M    | J    | m    | j    |      |      | α    | 又    | ∩    | ∟    | ト    | ÷    |
| 1110           | (7)              |      | .    | >    | N    | ^    | n    | →    |      |      | ε    | E    | ト    | °    | π    |      |
| 1111           | (8)              |      | /    | ?    | O    | _    | o    | ←    |      |      | 9    | ウ    | 又    | "    | o    | ■    |

## Example Initialization Program

8-bit Initialization:

```

/*****/
void command(char i)
{
    P1 = i;                //put data on output Port
    D_I =0;                //D/I=LOW : send instruction
    R_W =0;                //R/W=LOW : Write
    E = 1;
    Delay(1);              //enable pulse width >= 300ns
    E = 0;                 //Clock enable: falling edge
}
/*****/
void write(char i)
{
    P1 = i;                //put data on output Port
    D_I =1;                //D/I=HIGH : send data
    R_W =0;                //R/W=LOW : Write
    E = 1;
    Delay(1);              //enable pulse width >= 300ns
    E = 0;                 //Clock enable: falling edge
}
/*****/
void init()
{
    E = 0;
    Delay(100);            //Wait >40 msec after power is applied
    command(0x30);         //command 0x30 = Wake up
    Delay(30);             //must wait 5ms, busy flag not available
    command(0x30);         //command 0x30 = Wake up #2
    Delay(10);             //must wait 160us, busy flag not available
    command(0x30);         //command 0x30 = Wake up #3
    Delay(10);             //must wait 160us, busy flag not available
    command(0x38);         //Function set: 8-bit/2-line
    command(0x10);         //Set cursor
    command(0x0c);         //Display ON; Cursor ON
    command(0x06);         //Entry mode set
}
/*****/
```

4-bit Initialization:

```

/*****/
void command(char i)
{
    P1 = i;                //put data on output Port
    D_I = 0;              //D/I=LOW : send instruction
    R_W = 0;              //R/W=LOW : Write
    Nybble();             //Send Upper 4 bits
    i = i<<4;             //Shift over by 4 bits
    P1 = i;                //put data on output Port
    Nybble();             //Send upper 4 bits
}
/*****/
void write(char i)
{
    P1 = i;                //put data on output Port
    D_I = 1;              //D/I=HIGH : send data
    R_W = 0;              //R/W=LOW : Write
    Nybble();             //Clock Upper 4 bits
    i = i<<4;             //Shift over by 4 bits
    P1 = i;                //put data on output Port
    Nybble();             //Clock upper 4 bits
}
/*****/
void Nybble()
{
    E = 1;
    Delay(1);              //enable pulse width >= 300ns
    E = 0;                 //Clock enable: falling edge
}
/*****/
void init()
{
    P1 = 0;
    P3 = 0;
    Delay(100);            //Wait >40 msec after power is applied
    P1 = 0x30;             //put 0x30 on the output port
    Delay(30);             //must wait 5ms, busy flag not available
    Nybble();              //command 0x30 = Wake up
    Delay(10);             //must wait 160us, busy flag not available
    Nybble();              //command 0x30 = Wake up #2
    Delay(10);             //must wait 160us, busy flag not available
    Nybble();              //command 0x30 = Wake up #3
    Delay(10);             //can check busy flag now instead of delay
    P1= 0x20;              //put 0x20 on the output port
    Nybble();              //Function set: 4-bit interface
    command(0x28);         //Function set: 4-bit/2-line
    command(0x10);         //Set cursor
    command(0x0F);         //Display ON; Blinking cursor
    command(0x06);         //Entry Mode set
}
/*****/

```

## Quality Information

| Test Item                             | Content of Test   | Test Condition  | Note |
|---------------------------------------|---|---|------|
| High Temperature storage              | Endurance test applying the high storage temperature for a long time.   | +80°C, 200 Hrs.   | 2    |
| Low Temperature storage               | Endurance test applying the low storage temperature for a long time.  | -30°C, 200 Hrs.   | 1,2  |
| High Temperature Operation            | Endurance test applying the electric stress (voltage & current) and the high thermal stress for a long time.                    | +70°C, 200 Hrs.   | 2    |
| Low Temperature Operation             | Endurance test applying the electric stress (voltage & current) and the low thermal stress for a long time.                     | -20°C, 200 Hrs.   | 1,2  |
| High Temperature / Humidity Operation | Endurance test applying the electric stress (voltage & current) and the high thermal with high humidity stress for a long time. | +60°C, 90% RH, 96 Hrs.  | 1,2  |
| Thermal Shock resistance              | Endurance test applying the electric stress (voltage & current) during a cycle of low and high thermal stress.                  | 0°C,30min -> 25°C,5min -> 70°C,30min = 1 cycle<br>10 cycles                           |      |
| Vibration test                        | Endurance test applying vibration to simulate transportation and use.   | 10-55Hz, 1.5mm amplitude.<br>60 sec in each of 3 directions X, Y, Z<br>For 15 minutes | 3    |
| Static electricity test               | Endurance test applying electric static discharge.  | V <sub>s</sub> =±800V, R <sub>s</sub> =330Ω, C <sub>s</sub> =150pF<br>10 Times        |      |

**Note 1:** No condensation to be observed.

**Note 2:** Conducted after 4 hours of storage at 25°C, 0%RH.

**Note 3:** Test performed on product itself, not inside a container.

## Precautions for using LCDs/LCMs

See Precautions at [www.newhavendisplay.com/specs/precautions.pdf](http://www.newhavendisplay.com/specs/precautions.pdf)

## Warranty Information and Terms & Conditions

[http://www.newhavendisplay.com/index.php?main\\_page=terms](http://www.newhavendisplay.com/index.php?main_page=terms)

## X-ON Electronics

Largest Supplier of Electrical and Electronic Components

*Click to view similar products for [LCD Character Display Modules & Accessories](#) category:*

*Click to view products by [Newhaven Display](#) manufacturer:*

Other Similar products are found below :

[HG9Z-AC501](#) [HG9Z-SCI25B](#) [LCM-S01602DTRA-3](#) [HG9Z-XC213](#) [EA FL-10P](#) [MDLS-161612-G-LV-LED4G](#) [MDLS-81809-LV-GLED4G](#)  
[MDLS-20265-LV-GLED4G](#) [NMTC-S16205DFYHSAY-22](#) [NHD-0420AZ-FSW-GBW-33V33-0](#) [CM1644-SGR1](#) [162A BC BW](#) [LCM-](#)  
[S02002DSM-Y](#) [162D BA BC](#) [HDM24216H-2-P9XS](#) [DEM 16207 SYH-PY](#) [RC0802A1-LLG-JWVE](#) [RC0802A1-LLR-JWVE](#) [RC0802A-](#)  
[TIW-ESV](#) [RC1202A-BIY-CSX](#) [RC1202A-BIY-ESX](#) [RC1602A-BIW-CSV](#) [RC1602A-YHW-CSV](#) [RC1602B-GHY-CSXD](#) [RC1602B-TIW-](#)  
[CSV](#) [RC1602B-YHY-CSVD](#) [RC1602D-GHY-ESX](#) [RC2002A2-LLB-JSVE](#) [RC2002A-GHG-CSV](#) [RC2004A-BIW-ESX](#) [RC2004A-GHW-](#)  
[CSV](#) [RC2004A-LLB-JSVE](#) [RC2004A-LLH-JSV](#) [RC2004A-LLR-JSVE](#) [DEM 08171 SYH-LY](#) [DEM 08172 SYH-PY](#) [DEM16101SYH-LY](#)  
[DEM 16209 SBH-PW-N](#) [DEM 16210 SGH](#) [DEM 16214 FGH-PW](#) [DEM 16216 FDH-P\(RGB\)-N](#) [DEM16216SYH-LY](#) [DEM 16217 SYH-PY](#)  
[DEM 16221 SYH](#) [DEM 16221 SYH \(FFCF/TR\)/V](#) [DEM 16227 FGH-PW](#) [DEM 16227 SBH-PW-N](#) [DEM 16227 SYH-LY](#) [DEM 20231 SYH-](#)  
[PY-CYR22](#) [DEM 20232 SBH-PW-N](#)