

NHD-240128WG-ATFH-VZ#

Graphic Liquid Crystal Display Module

NHD-	Newhaven Display
240128-	240 x 128 Pixels
WG-	Display Type: Graphic
A-	Model
T-	White LED Backlight
F-	FSTN (+)
H-	Transflective, 6:00 Optimal View, Wide Temperature
VZ#-	Built-in Negative Voltage
	RoHS Compliant

Newhaven Display International, Inc.

2661 Galvin Ct.

Elgin IL, 60124

Ph: 847-844-8795

Fax: 847-844-8796

www.newhavendisplay.com

nhtech@newhavendisplay.com

nhsales@newhavendisplay.com

Document Revision History

Revision	Date	Description	Changed by
0	4/28/10	User guide reformat	MC
1	2/9/11	Pin description updated	AK
2	4/26/11	Electrical characteristics updated	AK
3	4/13/12	Mechanical drawing updated	AK
4	5/14/14	Electrical characteristics, Mechanical drawing updated	ML
5	12/22/14	Electrical characteristics & Mechanical drawing updated	PB
6	3/1/17	Mechanical Drawing, Electrical Characteristics Updated	SB
7	11/12/18	Current Draw Note Updated, Drawing Reformat	SB
8	8/14/20	Implemented Improvements in LCD Glass; Updated 2D Mechanical Drawing & Quality Information Part Revision Updated to Rev1A	AS
9	9/1/20	Corrected Backlight Current Condition under Electrical Characteristics	AS

Functions and Features

- 240 x 128 pixels
- Built-in RA6963 controller
- +5.0V power supply
- RoHS compliant

Mechanical Drawing

A
B
C
D
E
F

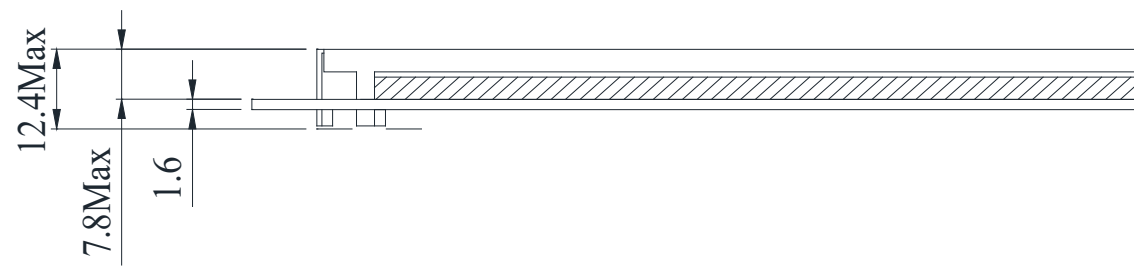
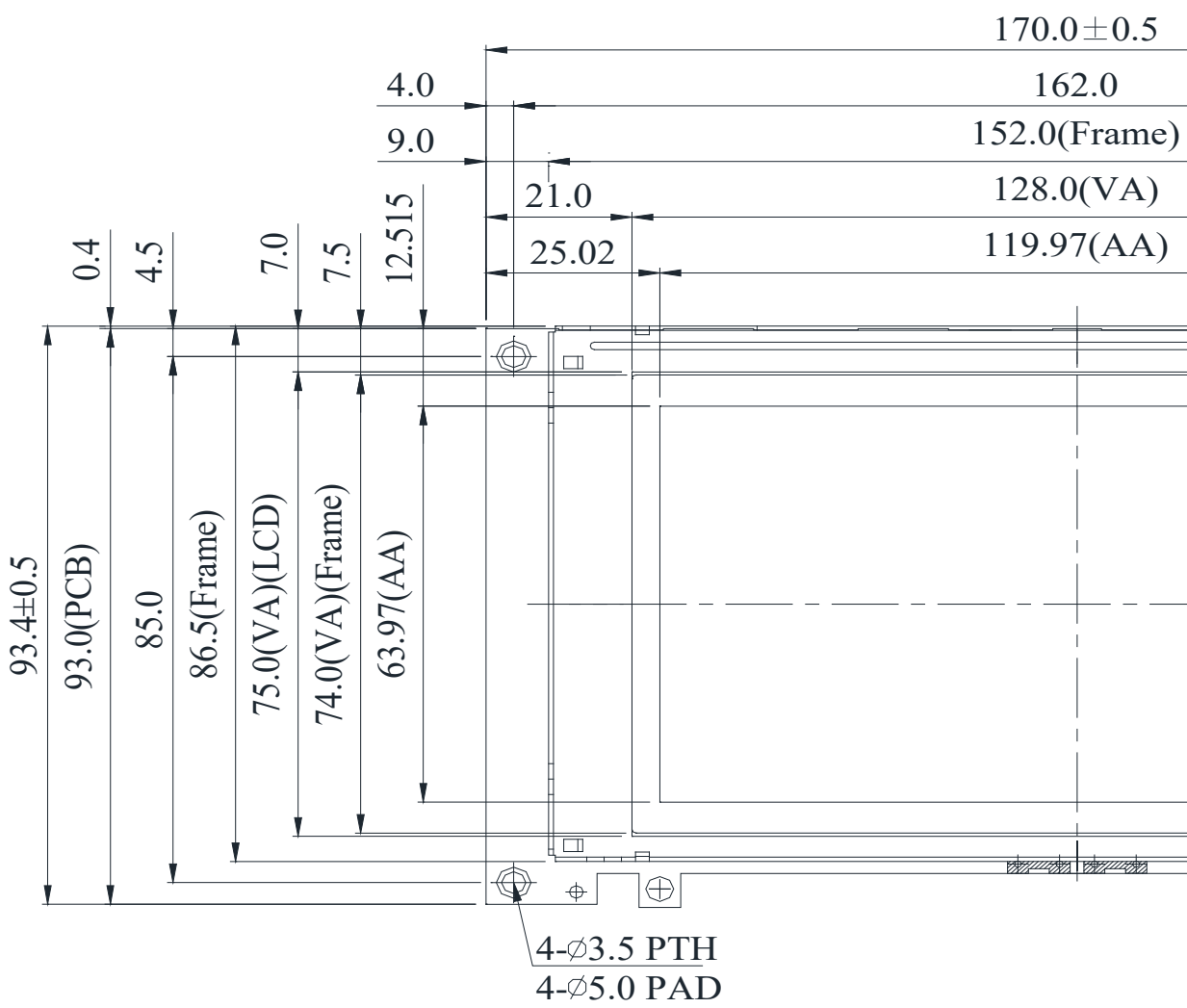

Notes:

1. Driver: 1/128 Duty
2. Display Mode: FSTN Positive / Transflective
3. Optimal View: 6:00
4. Voltage: 5.0V VDD, 18V VLCD
5. Backlight: White LED
6. Driver IC: RA6963

12.00

1 2 3 4

Pin Description and Wiring Diagram

Pin No.	Symbol	External Connection	Function Description
1	FGND	Power Supply	Frame Ground
2	V _{SS}	Power Supply	Ground
3	V _{DD}	Power Supply	Supply Voltage for LCD and Logic (+5.0V)
4	V ₀	Adj. Power Supply	Supply Voltage for Contrast (approx. -13.0V)
5	\overline{WR}	MPU	Active LOW Write signal
6	\overline{RD}	MPU	Active LOW Read signal
7	\overline{CE}	MPU	Active LOW Chip Enable signal
8	C/D	MPU	Command/Data selection: '1' = Command, '0' = Data
9	V _{EE}	Power Supply	Negative Voltage output (-16V)
10	RESET	MPU	Active LOW Reset signal
11-18	DB0~DB7	MPU	8-bit bi-directional data bus
19	FS	Power Supply	Font Selection: '1' = 6x8, '0' = 8x8
20	RV	MPU	Reverse display signal: '1' = Reverse Display, '0' = Normal Display

Recommended LCD connector: 20 pin, 2.54mm pitch pins

Backlight connector: JST p/n: XHP-3 **Mates with:** JST p/n: B 3B-XH-A

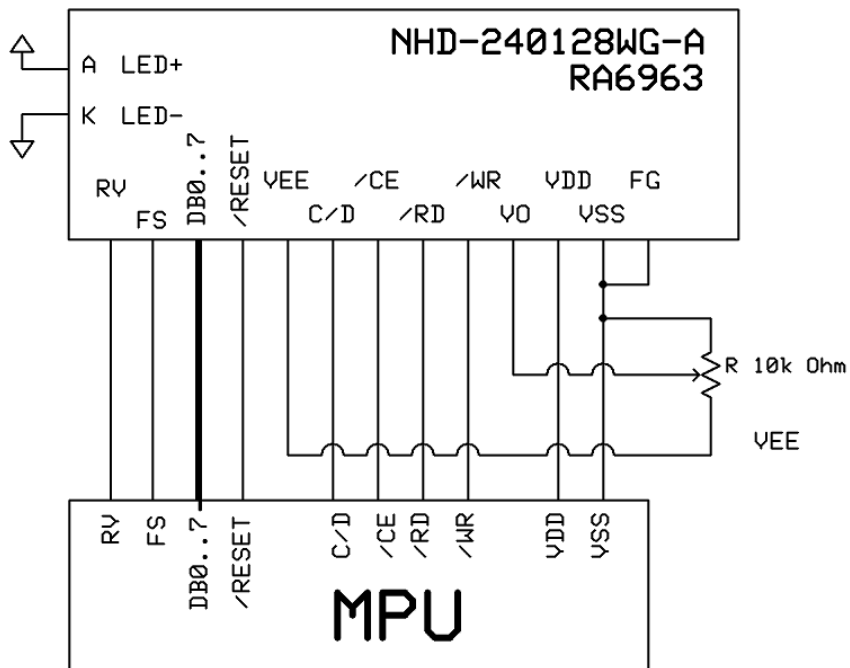

Electrical Characteristics

Item	Symbol	Condition	Min.	Typ.	Max.	Unit
Operating Temperature Range	T_{OP}	Absolute Max	-20	-	+70	°C
Storage Temperature Range	T_{ST}	Absolute Max	-30	-	+80	°C
Supply Voltage	V_{DD}	-	3.0	5.0	5.5	V
Supply Current	I_{DD}	$V_{DD} = 5.0V$ $T_{OP} = 25^{\circ}C$	15	30	60	mA
Supply for LCD (contrast)	$V_{DD} - V_0$		17.5	18.0	18.5	V
"H" Level input	V_{IH}	-	$0.8 * V_{DD}$	-	V_{DD}	V
"L" Level input	V_{IL}	-	V_{SS}	-	$0.15 * V_{DD}$	V
"H" Level output	V_{OH}	-	$V_{DD} - 0.3$	-	V_{DD}	V
"L" Level output	V_{OL}	-	V_{SS}	-	0.3	V
Backlight Supply Current	I_{LED}	-	-	128	160	mA
Backlight Supply Voltage	V_{LED}	$I_{LED} = 128mA$	3.4	3.5	3.6	V

*Backlight is current driven; do not supply more than 160 mA. Luminance is directly related to Backlight Supply Current.

Optical Characteristics

Item	Symbol	Condition	Min.	Typ.	Max.	Unit
Optimal Viewing Angles	Top	$CR \geq 2$	-	30	-	°
	Bottom		-	60	-	°
	Left		-	45	-	°
	Right		-	45	-	°
Contrast Ratio	CR	-	2	5	-	-
Response Time	Rise	$T_{OP} = 25^{\circ}C$	-	200	300	ms
	Fall		-	250	350	ms

Controller Information

Built-in RA6963.

Please download specification at http://www.newhavendisplay.com/app_notes/RA6963.pdf

Table of Commands

Command	Code	D1	D2	Function
Registers Setting	00100001	X address	Y address	Set cursor pointer
	00100010	Data	00h	Set Offset Register
	00100100	Low address	High address	Set Address pointer
Set Control Word	01000000	Low address	High address	Set Text Home Address
	01000001	Columns	00h	Set Text Area
	01000010	Low address	High address	Set Graphic Home Address
	01000011	Columns	00h	Set Graphic Area
Mode Set	1000X000	--	--	OR mode
	1000X001	--	--	EXOR mode
	1000X011	--	--	AND mode
	1000X100	--	--	Text Attribute mode
	10000XXX	--	--	Internal CG ROM mode
	10001XXX	--	--	External CG RAM mode
Display Mode	10010000	--	--	Display off
	1001XX10	--	--	Cursor on, blink off
	1001XX11	--	--	Cursor on, blink on
	100101XX	--	--	Text on, graphic off
	100110XX	--	--	Text off, graphic on
	100111XX	--	--	Text on, graphic on
Cursor Pattern Select	10100000	--	--	1-line cursor
	10100001	--	--	2-line cursor
	10100010	--	--	3-line cursor
	10100011	--	--	4-line cursor
	10100100	--	--	5-line cursor
	10100101	--	--	6-line cursor
	10100110	--	--	7-line cursor
	10100111	--	--	8-line cursor
Data Read/Write	11000000	Data	--	Data Write and Increment ADP
	11000001	--	--	Data Read and Increment ADP
	11000010	Data	--	Data Write and Decrement ADP
	11000011	--	--	Data Read and Decrement ADP
	11000100	Data	--	Data Write and Non-variable ADP
	11000101	--	--	Data Read and Non-variable ADP
Data auto Read/Write	10110000	--	--	Set Data Auto Write
	10110001	--	--	Set Data Auto Read
	10110010	--	--	Auto Reset
Screen Peek	11100000	--	--	Screen Peek
Screen Copy	11101000			Screen Copy
Bit Set/Reset	11110XXX	--	--	Bit Reset
	11111XXX	--	--	Bit Set
	1111X000	--	--	Bit 0 (LSB)
	1111X001	--	--	Bit 1
	1111X010	--	--	Bit 2
	1111X011	--	--	Bit 3
	1111X100	--	--	Bit 4
	1111X101	--	--	Bit 5
	1111X110	--	--	Bit 6
1111X111	--	--	Bit 7 (MSB)	
Screen Reverse	11010000	Data	--	Whole screen reverse

Timing Characteristics

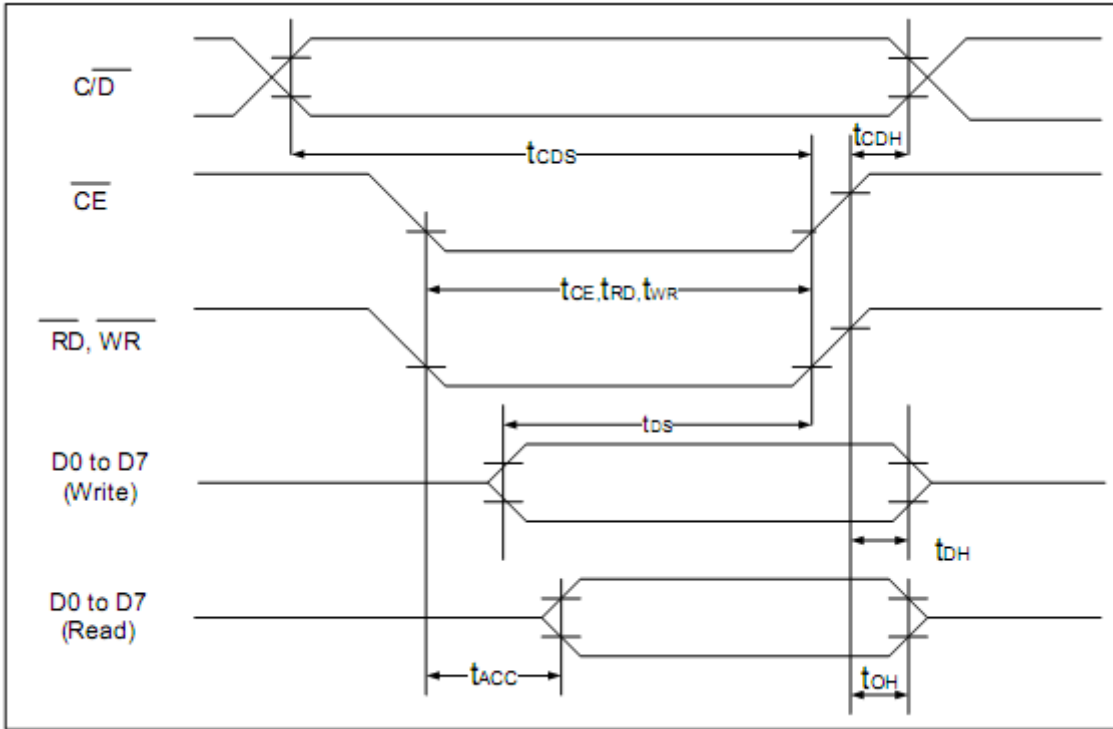

($V_{DD}=+5V\pm 5\%$, $GND=0V$, $T_a = -20$ to $+70^\circ C$)

Item	Symbol	Test Conditions	Min.	Max.	Unit
$\overline{C/D}$ Set Up Time	t_{CDS}	--	100	--	ns
$\overline{C/D}$ Hold Time	t_{CDH}	--	10	--	ns
\overline{CE} , \overline{RD} , \overline{WR} Pulse Width	t_{CE}, t_{RD}, t_{WR}	--	80	--	ns
Data Set Up Time	t_{DS}	--	80	--	ns
Data Hold Time	t_{DH}	--	40	--	ns
Access Time	t_{ACC}	--	--	150	ns
Output Hold Time	t_{OH}	--	10	50	ns

Built-in Font Table

LSB MSB	0	1	2	3	4	5	6	7	8	9	A	B	C	D	E	F
0		!	"	#	\$	%	&	'	()	*	+	,	-	.	/
1	0	1	2	3	4	5	6	7	8	9	:	;	<	=	>	?
2	A	B	C	D	E	F	G	H	I	J	K	L	M	N	O	
3	P	Q	R	S	T	U	W	X	Y	Z	[\]	^	_	
4	`	a	b	c	d	e	f	g	h	i	j	k	l	m	n	o
5	p	q	r	s	t	u	v	w	x	y	z	{		}	~	
6	Q	U	E	A	A	A	A	Q	E	E	E	i	i	i	A	A
7	E	A	E	O	O	O	O	O	O	O	O	Q	E	E	E	f

Example Program Code

```
//-----  
Sub Writecom  
P1 = A                'move data to port 1  
Set P3.0              'set I/D for instruction  
Reset P3.1            'reset /CS  
Reset P3.4            'reset /WR  
Set P3.1              'set /CS  
Set P3.4              'set /WR  
End Sub  
  
Sub Writedata  
P1 = A                'move data to port 1  
Reset P3.0            'reset I/D for instruction  
Reset P3.1  
Reset P3.4            'toggle /CS and /WR  
Set P3.1  
Set P3.4  
End Sub  
  
//-----  
Sub Init  
Set P3.6  
Set P3.7  
Reset P3.3            'reset FS  
A = &H00  
Call Writedata  
Call Writedata        'text address = 0000h  
A = &H40  
Call Writecom         'text home address set  
A = &H00  
Call Writedata  
A = &H40              'graphic home address = 4000h  
Call Writedata  
A = &H42  
Call Writecom         'graphic home address set  
A = &H1E  
Call Writedata  
A = &H00              'text area address = 001Eh  
Call Writedata  
A = &H41  
Call Writecom         'text area control set  
A = &H1E  
Call Writedata  
A = &H00              'graphic area = 001Eh  
Call Writedata  
A = &H43  
Call Writecom         'graphic area control set  
A = &H80  
Call Writecom         'set display mode  
End Sub
```

Quality Information

Test Item	Content of Test	Test Condition	Note
High Temperature storage	Endurance test applying the high storage temperature for a long time.	+80°C, 200 Hrs.	2
Low Temperature storage	Endurance test applying the low storage temperature for a long time.	-30°C, 200 Hrs.	1,2
High Temperature Operation	Endurance test applying the electric stress (voltage & current) and the high thermal stress for a long time.	+70°C, 200 Hrs.	2
Low Temperature Operation	Endurance test applying the electric stress (voltage & current) and the low thermal stress for a long time.	-20°C, 200 Hrs.	1,2
High Temperature / Humidity Operation	Endurance test applying the electric stress (voltage & current) and the high thermal with high humidity stress for a long time.	+60°C, 90% RH, 96 Hrs.	1,2
Thermal Shock resistance	Endurance test applying the electric stress (voltage & current) during a cycle of low and high thermal stress.	-20°C, 30min -> 25°C, 5min -> 70°C, 30min = 1 cycle 10 Cycles	
Vibration test	Endurance test applying vibration to simulate transportation and use.	10-55Hz, 1.5mm amplitude. 60 sec in each of 3 directions X,Y,Z For 15 minutes	3
Static electricity test	Endurance test applying electric static discharge.	Air: ±800V 150pF/330Ω, 5 Times	
		Contact: ±600V 150pF/330Ω, 5 Times	

Note 1: No condensation to be observed.

Note 2: Conducted after 4 hours of storage at 25°C, 0%RH.

Note 3: Test performed on product itself, not inside a container.

Precautions for using LCDs/LCMs

See Precautions at www.newhavendisplay.com/specs/precautions.pdf

Warranty Information

See Terms & Conditions at http://www.newhavendisplay.com/index.php?main_page=terms

X-ON Electronics

Largest Supplier of Electrical and Electronic Components

Click to view similar products for [LCD Graphic Display Modules & Accessories](#) category:

Click to view products by [Newhaven Display](#) manufacturer:

Other Similar products are found below :

[HDM64GS12L-Y11S](#) [MGLS-240128-Z05](#) [DEM 128064U FGH](#) [DEM 240064E FGH-PW](#) [11557](#) [18396](#) [15932](#) [HDM64GS24L-2-Y14S](#)
[RG12864C-YHW-V](#) [RG12864K-BIW-VBG](#) [DEM 128064A SBH-PW-N](#) [DEM 128064B SBH-PW-N](#) [DEM 128064G FGH-PW](#) [DEM](#)
[128064O FGH-PW](#) [DEM 128064O SBH-PW-N](#) [DEM 128064Q SBH-PW-N](#) [DEM 128128D FGH-PW](#) [DEM 240064B FGH-PW](#) [DEM](#)
[240064B SBH-PW-N](#) [DEM 320240B FGH-PW-N](#) [EA W240-7KHLW](#) [16239](#) [RX12864A1-BIW](#) [RX240128A-FHW](#) [RX240160A-FHW](#)
[18370](#) [19340](#) [RG24064A-TIW-V](#) [EA FL-14P](#) [GLK19264A-7T-1U-TCI](#) [GLK19264A-7T-1U-USB-FGW](#) [GLK19264A-7T-1U-USB-WB](#)
[DEM 320240I SBH-PW-N](#) [GLK24064R-25-1U-WB](#) [DEM 240160A FGH-PW](#) [RG12864B1-BIW-V](#) [RG240128B-BIW-V](#) [RG24064A-FHW-](#)
[V](#) [DEM 122032B SYH-LY](#) [DEM 128064A FGH-PW \(A-TOUCH\)](#) [DEM 128064A SBH-PW-N \(A-TOUCH\)](#) [DEM 128064B FGH-PW](#) [DEM](#)
[128064H SBH-PW-N](#) [DEM 128064J FGH-PW](#) [DEM 128064P FGH-PW](#) [DEM 320240C SBH-PW-N](#) [DEM 320240I FGH-PW](#) [DEM 128064F](#)
[SBH-PW-N](#) [DEM 128128B1 FGH-PW](#) [DEM 240064C1 FGH-PW](#)