

**Product Specification** \_\_\_\_\_

**NHD-**

**TFT Liquid Crystal Display**

**NHD -**            Newhaven Display



## Table of Contents

Document Revision History .....	2
Functions and Features .....	2
Mechanical Drawing .....	3
Pin Description .....	4
Electrical Characteristics .....	5
Optical Characteristics .....	5
Driver Information .....	6
Capacitive Touch Panel Material Characteristics .....	6
Capacitive Touch Panel Registers .....	7
Timing Characteristics for TFT .....	10
Timing Characteristics for Touch Panel .....	14
Quality Information .....	17

---

## Additional Resources

- **Support Forum:** <http://www.nhdforum.newhavendisplay.com>
- **Github:** <https://github.com/newhavendisplay>
- **Example Code:** [https://www.newhavendisplay.com/example\\_code.html](https://www.newhavendisplay.com/example_code.html)
- **Knowledge Center:** [https://www.newhavendisplay.com/knowledge\\_center.html](https://www.newhavendisplay.com/knowledge_center.html)
- **Quality Center:** [https://www.newhavendisplay.com/quality\\_center.html](https://www.newhavendisplay.com/quality_center.html)
- **Precautions for using LCDs/LCMs:** <https://www.newhavendisplay.com/specs/precautions.pdf>
- **Warranty / Terms & Conditions:** <https://www.newhavendisplay.com/terms.html>



## Document Revision History

Revision	Date	Description	Changed By
0	11/2/20	Initial Release	AS

## Functions and Features

- **800xRGBx480 resolution, up to 16.7M colors**
- **27-LED backlight**
- **24 bit RGB interface**
- **Sunlight Readable**
- **Enhanced Optical Characteristics**
- **Wide Viewing Angles**
- **Capacitive touch panel with controller**
  - **10-Point multi-touch input**
  - **Gesture input**
    - **Zoom In/Out**
    - **Swipe Up/Down/Left/Right**

# Mechanical Drawing

SYMBOL	REVISION	DATE

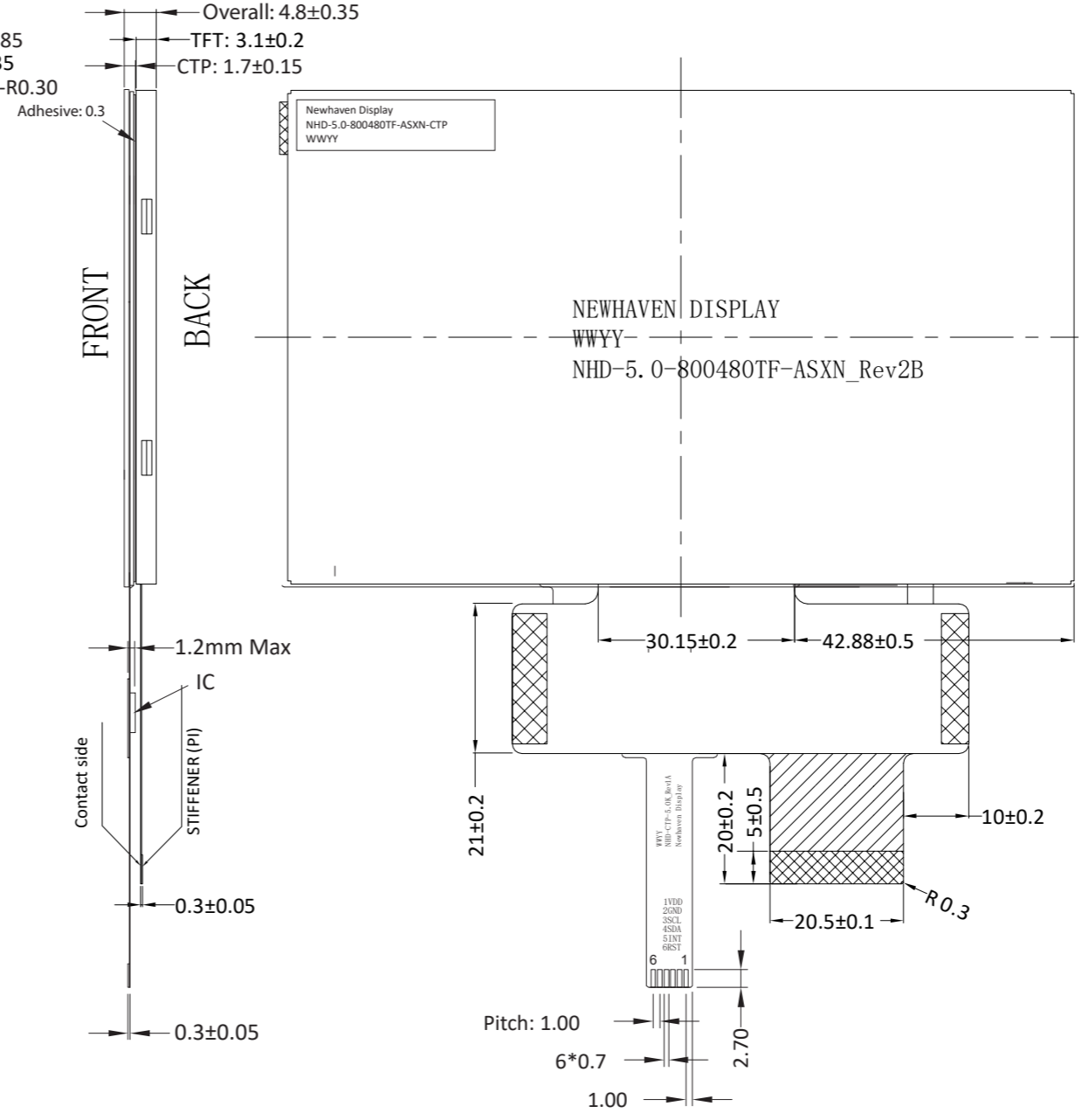
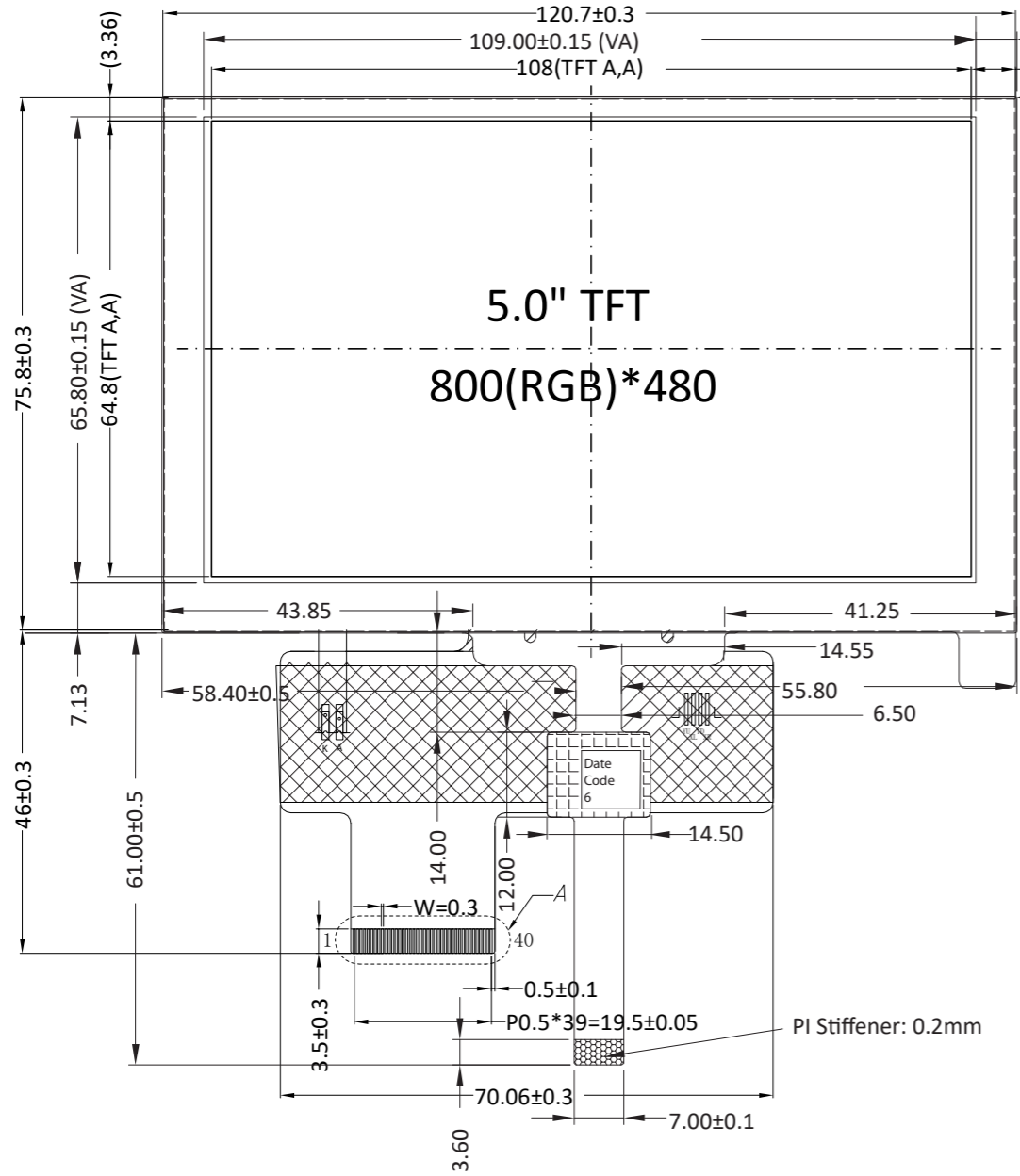

NO.	PIN NAME
1	VLED-
2	VLED+
3	GND
4	VDD
5	R0
6	R1
7	R2
8	R3
9	R4
10	R5
11	R6
12	R7
13	G0
14	G1
15	G2
16	G3
17	G4
18	G5
19	G6
20	G7
21	B0
22	B1
23	B2
24	B3
25	B4
26	B5
27	B6
28	B7
29	GND
30	CLKIN
31	STBYB
32	HSD
33	VSD
34	DEN
35	NC
36	GND
37	XR
38	YD
39	XL
40	YU

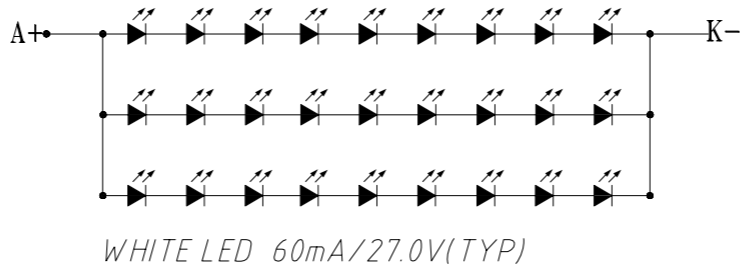

- Notes:
- 1) Display Size: 5" Diagonal, 800 x 480 Pixels
  - 2) Display Mode: MVA / Transmissive / Normally White / Anti-Glare
  - 3) Driver IC: ILI6122
  - 4) LCD Voltage: 3.3V (TYP)
  - 5) Backlight: White LED / 60mA (TYP) / 27V (TYP)
  - 6) Luminance: 820 cd/m<sup>2</sup>
  - 7) Operating Temperature: -20°C to 70°C
  - 8) Storage Temperature: -30°C to 80°C
  - 9) Touch Panel: PCAP

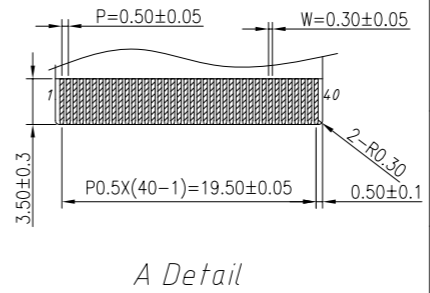

**Standard Tolerance:**  
(Unless otherwise specified)

Linear: ±0.3mm

**Unless otherwise specified:**  
• Dimensions are in Millimeters  
• Third Angle Projection

**NEWHAVEN DISPLAY INTERNATIONAL**

Drawing/Part Number: **NHD-5.0-800480TF-ASXN-CTP**

Revision: **2B**

Size: **A3**

Scale: **NS**

Do Not Scale Drawing

Sheet 1 of 1

This drawing is solely the property of Newhaven Display International, Inc. The information it contains is not to be disclosed, reproduced or copied in whole or part without written approval from Newhaven Display.

## Pin Description

### TFT:

Pin No.	Symbol	External Connection	Function Description
1	LED-	LED Power Supply	Ground for Backlight
2	LED+	LED Power Supply	Backlight Power Supply (60mA @ 27V)
3	GND	Power Supply	Ground
4	V <sub>DD</sub>	Power Supply	Power supply for LCD and logic (3.3V)
5-12	[R0-R7]	MPU	Red Data Signals
13-20	[G0-G7]	MPU	Green Data Signals
21-28	[B0-B7]	MPU	Blue Data Signals
29	GND	Power Supply	Ground
30	CLKIN	MPU	Clock for input data (Rising Edge)
31	STBYB	MPU	1: Normal Operation;0: Standby Mode
32	HSD	MPU	Line synchronization signal
33	VSD	MPU	Frame synchronization signal
34	DEN	MPU	Data Enable signal
35	NC	-	No Connect
36	GND	Power Supply	Ground
37	XR	-	No Connect
38	YD	-	No Connect
39	XL	-	No Connect
40	YU	-	No Connect

**Recommended LCD connector:** 0.5mm pitch 40-Conductor FFC. Molex p/n: 54104-4031 (top contact)

**Backlight connector:** on LCD connector

**Mates with:** ---

### Capacitive Touch Panel:

Pin No.	Symbol	External Connection	Function Description
1	V <sub>CC</sub>	Power Supply	Power supply for logic (3.3V)
2	GND	Power Supply	Ground
3	SCL	MPU	Serial I2C Clock (Requires pull-up resistor)
4	SDA	MPU	Serial I2C Data (Requires pull-up resistor)
5	/INT	MPU	Interrupt signal from touch panel module to host
6	/RESET	MPU	Active LOW Reset signal (Do not tie to V <sub>CC</sub> )

**Recommended connector:** 1.0mm pitch 6-Conductor FFC. Molex p/n: 52271-0679

The ILI6122 driver IC is configured for DE Mode by default which eliminates the need to depend on HSD and VSD timing signals. Using DE mode in place of Sync mode, the display will no longer be affected by changes to the sync timing or porch settings in the event of a driver IC change. This will maintain a consistent display performance for any driver IC changes that may occur in the future.

The ILI6122 driver will treat the data on the Dx[7:0] RGB data bus as active display data while DEN is at “H” level and ignore the data on the Dx[7:0] RGB data bus while DEN is at “L” level.

Sync Mode can still be provided as the default setting but will need to be ordered as a custom option.

## Electrical Characteristics

### TFT:

Item	Symbol	Condition	Min.	Typ.	Max.	Unit
Operating Temperature Range	T <sub>OP</sub>	Absolute Max	-20	-	+70	°C
Storage Temperature Range	T <sub>ST</sub>	Absolute Max	-30	-	+80	°C
Supply Voltage	V <sub>DD</sub>	-	3.0	3.3	3.6	V
Supply Current	I <sub>DD</sub>	V <sub>DD</sub> = 3.3V	43	85	130	mA
"H" Level input	V <sub>IH</sub>	-	0.7 * V <sub>DD</sub>	-	V <sub>DD</sub>	V
"L" Level input	V <sub>IL</sub>	-	GND	-	0.3 * V <sub>DD</sub>	V
"H" Level output	V <sub>OH</sub>	-	V <sub>DD</sub> - 0.4	-	V <sub>DD</sub>	V
"L" Level output	V <sub>OL</sub>	-	-	-	GND + 0.4	V
Backlight Supply Current	I <sub>LED</sub>	-	-	60	75	mA
Backlight Supply Voltage	V <sub>LED</sub>	I <sub>LED</sub> = 60mA T <sub>OP</sub> = 25°C	25.2	27.0	30.6	V
Backlight Lifetime*	-		30,000	-	-	Hrs.

\*Backlight lifetime is rated as Hours until **half-brightness**, under normal operating conditions. The LED of the backlight is driven by current drain; drive voltage is for reference only. Drive voltage must be selected to ensure backlight current drain is below MAX level stated.

### Capacitive Touch Panel:

Item	Symbol	Condition	Min.	Typ.	Max.	Unit
Operating Temperature Range	T <sub>OP</sub>	Absolute Max	-20	-	+70	°C
Storage Temperature Range	T <sub>ST</sub>	Absolute Max	-30	-	+80	°C
Supply Voltage	V <sub>DD</sub>	-	2.8	3.3	3.6	V
Supply Current – Operating	I <sub>DD</sub>	V <sub>DD</sub> = 3.3V T <sub>OP</sub> = 25°C	-	12	20	mA
Supply Current – Hibernate	I <sub>DD</sub>		-	1.0	-	µA
"H" Level Input	V <sub>IH</sub>	-	0.7 * V <sub>DD</sub>	-	V <sub>DD</sub>	V
"L" Level Input	V <sub>IL</sub>	-	V <sub>SS</sub>	-	0.3 * V <sub>DD</sub>	V
"H" Level Output	V <sub>OH</sub>	-	0.7 * V <sub>DD</sub>	-	V <sub>DD</sub>	V
"L" Level Output	V <sub>OL</sub>	-	V <sub>SS</sub>	-	0.3*V <sub>DD</sub>	V

## Optical Characteristics:

Item	Symbol	Condition	Min.	Typ.	Max.	Unit	
Optimal Viewing Angles	Top	CR ≥ 10	-	70	-	°	
	Bottom		-	70	-	°	
	Left		-	70	-	°	
	Right		-	70	-	°	
Contrast Ratio	CR	-	400	500	-	-	
Luminance	L <sub>V</sub>	I <sub>LED</sub> = 60 mA	650	820	-	cd/m <sup>2</sup>	
Response Time (Rise + Fall)	T <sub>R</sub> + T <sub>F</sub>	T <sub>OP</sub> = 25°C	-	30	40	ms	
Chromaticity	Red	X <sub>R</sub>	-	0.530	0.570	0.610	-
		Y <sub>R</sub>	-	0.275	0.315	0.355	-
	Green	X <sub>G</sub>	-	0.321	0.361	0.401	-
		Y <sub>G</sub>	-	0.546	0.586	0.626	-
	Blue	X <sub>B</sub>	-	0.105	0.145	0.185	-
		Y <sub>B</sub>	-	0.054	0.094	0.134	-
	White	X <sub>W</sub>	-	0.275	0.315	0.355	-
		Y <sub>W</sub>	-	0.287	0.327	0.355	-

## Capacitive Touch Panel Material Characteristics:

Property	Requirement	Unit
IC	FT5426	-
ITO Glass thickness	0.55	mm
Surface Hardness	≥6	H
Light transmission	82%	-
Operating Humidity	20~90	RH
Storage Humidity	20~90	RH

## Driver/Controller Information

### TFT:

Built-in ILI6122 Source Driver: <https://www.newhavendisplay.com/appnotes/datasheets/LCDs/ILI6122.pdf>

Built-in ILI5960D Gate Driver: <http://www.newhavendisplay.com/appnotes/datasheets/LCDs/ILI5960D.pdf>

### Capacitive Touch Panel:

Built-in FocalTech FT5426 controller.

Please download specification at <http://www.newhavendisplay.com/appnotes/datasheets/touchpanel/FT5x26.pdf>

## Capacitive Touch Panel Registers

Register No.	Access	Register Name	Bits	Value	Description
01h	RO	Gesture ID	[7:0]	10	Swipe Up
				18h	Swipe Down
				1Ch	Swipe Left
				14h	Swipe Right
				48h	Zoom Out
				49h	Zoom In
				00	No gesture
02h	RO	Touch Points	[7:0]	0-Ah	0: No touch detected A: 10 touch points detected
03h	RO	TOUCH1_Event_Flag	[7:6]	0	Put Down
				1	Put Up
				2	Contact
				3	Reserved
03h	RO	TOUCH1_XH	[3:0]	0-1	Upper 4 bits of X touch coordinate
04h	RO	TOUCH1_XL	[7:0]	00 – FFh	Lower 8 bits of X touch coordinate
05h	RO	TOUCH1_YH	[3:0]	0-1	Upper 4 bits of Y touch coordinate
06h	RO	TOUCH1_YL	[7:0]	00 – FFh	Lower 8 bits of Y touch coordinate
07h	RO	TOUCH1_Weight	[7:0]		Touch Weight
08h	RO	TOUCH1_Misc	[3:0]	00-0Fh	Touch Area
09h	RO	TOUCH2_Event_Flag	[7:6]	0	Put Down
				1	Put Up
				2	Contact
				3	Reserved
09h	RO	TOUCH1_XH	[3:0]	0-1	Upper 4 bits of X touch coordinate
0Ah	RO	TOUCH2_XL	[7:0]	00 – FFh	Lower 8 bits of X touch coordinate
0Bh	RO	TOUCH2_YH	[3:0]	0-1	Upper 4 bits of Y touch coordinate
0Ch	RO	TOUCH2_YL	[7:0]	00 – FFh	Lower 8 bits of Y touch coordinate
0Dh	RO	TOUCH2_Weight	[7:0]		Touch Weight
0Eh	RO	TOUCH2_Misc	[3:0]	00-0Fh	Touch Area
0Fh	RO	TOUCH3_Event_Flag	[7:6]	0	Put Down
				1	Put Up
				2	Contact
				3	Reserved
0Fh	RO	TOUCH3_XH	[3:0]	0-1	Upper 4 bits of X touch coordinate
10	RO	TOUCH3_XL	[7:0]	00 – FFh	Lower 8 bits of X touch coordinate
11h	RO	TOUCH3_YH	[3:0]	0-1	Upper 4 bits of Y touch coordinate
12h	RO	TOUCH3_YL	[7:0]	00 – FFh	Lower 8 bits of Y touch coordinate
13h	RO	TOUCH3_Weight	[7:0]		Touch Weight
14h	RO	TOUCH3_Misc	[3:0]	00-0Fh	Touch Area
15h	RO	TOUCH4_Event_Flag	[7:6]	0	Put Down
				1	Put Up
				2	Contact
				3	Reserved
15h	RO	TOUCH4_XH	[3:0]	0-1	Upper 4 bits of X touch coordinate
16h	RO	TOUCH4_XL	[7:0]	00 – FFh	Lower 8 bits of X touch coordinate
17h	RO	TOUCH4_YH	[3:0]	0-1	Upper 4 bits of Y touch coordinate
18h	RO	TOUCH4_YL	[7:0]	00 – FFh	Lower 8 bits of Y touch coordinate
1Ah	RO	TOUCH4_Misc	[3:0]	00-0Fh	Touch Area
1Bh	RO	TOUCH5_Event_Flag	[7:6]	0	Put Down
				1	Put Up
				2	Contact
				3	Reserved



Register No.	Access	Register Name	Bits	Value	Description
1Bh	RO	TOUCH5_XH	[3:0]	0-1	Upper 4 bits of X touch coordinate
1Ch	RO	TOUCH5_XL	[7:0]	00 – FFh	Lower 8 bits of X touch coordinate
1Dh	RO	TOUCH5_YH	[3:0]	0-1	Upper 4 bits of Y touch coordinate
1Eh	RO	TOUCH5_YL	[7:0]	00 – FFh	Lower 8 bits of Y touch coordinate
1Fh	RO	TOUCH5_Weight	[7:0]		Touch Weight
20	RO	TOUCH5_Misc	[3:0]	00-0Fh	Touch Area
21h	RO	TOUCH6_Event_Flag	[7:6]	0	Put Down
				1	Put Up
				2	Contact
				3	Reserved
21h	RO	TOUCH6_XH	[3:0]	0-1	Upper 4 bits of X touch coordinate
22h	RO	TOUCH6_XL	[7:0]	00 – FFh	Lower 8 bits of X touch coordinate
23h	RO	TOUCH6_YH	[3:0]	0-1	Upper 4 bits of Y touch coordinate
24h	RO	TOUCH6_YL	[7:0]	00 – FFh	Lower 8 bits of Y touch coordinate
25h	RO	TOUCH6_Weight	[7:0]		Touch Weight
26h	RO	TOUCH6_Misc	[3:0]	00-0Fh	Touch Area
27h	RO	TOUCH7_Event_Flag	[7:6]	0	Put Down
				1	Put Up
				2	Contact
				3	Reserved
27h	RO	TOUCH7_XH	[3:0]	0-1	Upper 4 bits of X touch coordinate
28h	RO	TOUCH7_XL	[7:0]	00 – FFh	Lower 8 bits of X touch coordinate
29h	RO	TOUCH7_YH	[3:0]	0 – 1	Upper 4 bits of Y touch coordinate
2Ah	RO	TOUCH7_YL	[7:0]	00 – FFh	Lower 8 bits of Y touch coordinate
2Bh	RO	TOUCH7_Weight	[7:0]		Touch Weight
2Ch	RO	TOUCH7_Misc	[3:0]	00-0Fh	Touch Area
2Dh	RO	TOUCH8_Event_Flag	[7:6]	0	Put Down
				1	Put Up
				2	Contact
				3	Reserved
2Dh	RO	TOUCH8_XH	[3:0]	0 – 1	Upper 4 bits of X touch coordinate
2Eh	RO	TOUCH8_XL	[7:0]	00 – FFh	Lower 8 bits of X touch coordinate
2Fh	RO	TOUCH8_YH	[3:0]	0 – 1	Upper 4 bits of Y touch coordinate
30	RO	TOUCH8_YL	[7:0]	00 – FFh	Lower 8 bits of Y touch coordinate
31h	RO	TOUCH8_Weight	[7:0]		Touch Weight
32h	RO	TOUCH8_Misc	[3:0]	00-0Fh	Touch Area
33h	RO	TOUCH9_Event_Flag	[7:6]	0	Put Down
				1	Put Up
				2	Contact
				3	Reserved
33h	RO	TOUCH9_XH	[3:0]	0 – 1	Upper 4 bits of X touch coordinate
34h	RO	TOUCH9_XL	[7:0]	00 – FFh	Lower 8 bits of X touch coordinate
35h	RO	TOUCH9_YH	[3:0]	0 – 1	Upper 4 bits of Y touch coordinate
36h	RO	TOUCH9_YL	[7:0]	00 – FFh	Lower 8 bits of Y touch coordinate
37h	RO	TOUCH9_Weight	[7:0]		Touch Weight
38h	RO	TOUCH9_Misc	[3:0]	00 – 0Fh	Touch Area
39h	RO	TOUCH10_Event_Flag	[7:6]	0	Put Down
				1	Put Up
				2	Contact
				3	Reserved
39h	RO	TOUCH10_XH	[3:0]	0 – 1	Upper 4 bits of X touch coordinate
3Ah	RO	TOUCH10_XL	[7:0]	00 – FFh	Lower 8 bits of X touch coordinate
3Bh	RO	TOUCH10_YH	[3:0]	0 – 1	Upper 4 bits of Y touch coordinate
3Ch	RO	TOUCH10_YL	[7:0]	00 - FFh	Lower 8 bits of Y touch coordinate



Register No.	Access	Register Name	Bits	Value	Description
3Dh	RO	TOUCH10_Weight	[7:0]	00-FFh	Touch Weight
3Eh	RO	TOUCH10_Misc	[3:0]	00-0Fh	Touch Area
80	RW	ID_G_MC_THGROUP	[7:0]	00-FFh	Mutual-Capacitive touch Threshold / 4 Default: 4Bh
81h	RW	ID_G_MC_THPEAK	[7:0]	00-FFh	Mutual-Capacitive Peak Threshold / 4 Default: 46h
85h	RW	ID_G_THDIFF	[7:0]	00-FFh	Points Filtering Range Threshold / 16 Default: A0
86h	RW	ID_G_CTRL	[1:0]	0-1	Allowed to switch to monitor mode or not (1: Allowed, 0: Not Allowed)
88h	RW	ID_G_PERIODACTIVE	[3:0]	3h-Eh	Period of Active Status
89h	RW	ID_G_PERIODMONITOR	[7:0]	1Eh-FFh	Timer to enter "idle" while in Monitor (ms)
A1h	RO	ID_G_LIB_VERSION_H	[7:0]	00-FFh	App library version high-byte Default: 0
A2h	RO	ID_G_LIB_VERSION_L	[7:0]	00-FFh	App library version low-byte Default: 2h
A3h	RO	ID_G_CHIPER_HIGH	[7:0]	00-FFh	Chip Vendor ID Default: 0x54
A4h	RW	ID_G_MODE	[0]	0 1	INT Trigger Mode INT Polling Mode
A5h	RW	ID_G_PMODE	[1:0]	0 1 3	Active Monitor Sleep
A6h	RO	ID_G_FIRMID	[7:0]	00-FFh	Firmware ID Number Default: 1
A8h	RO	ID_G_VENODRID	[7:0]	00-FFh	CTPM Vendor's Chip ID Default: 79h
C0h	RW	ID_G_GLOVE_MODE_EN	[0]	0 1	Glove Mode Switch Disable Glove Mode Switch Enable
C1h	RW	ID_G_COVER_MODE_EN	[0]	0 1	Cover Mode Switch Disable Cover Mode Switch Enable

## Timing Characteristics – TFT Display

### Horizontal Input Timing

Parameter	Symbol	Value			Unit	Note
Horizontal Display Area	thd	800			MHz	
DCLK Frequency	fclk	Min	Typ	Max	MHz	
		-	33.3	50		
1 Horizontal Line	th	862	1056	1200	DCLK	
HSD Pulse Width	thpw	1	-	40		
HSD Back Porch (Blanking)	thb	46	46	46		
HSD Front Porch	thfp	16	210	354		

### Vertical Input Timing

Parameter	Symbol	Min	Typ	Max	Unit	Note
Vertical Display Area	tvd	480			H	
VSD Period Tim	tv	510	525	650		
VSD Pulse Width	tvpw	1	-	20		
VSD Back Porch (Blanking)	tvb	23	23	23		
VSD Front Porch	tvfp	7	22	147		

### AC Characteristics

Parameter	Symbol	Min	Typ	Max	Unit	Conditions
V <sub>DD</sub> Power ON Slew Rate	T <sub>POR</sub>	-	-	20	ms	From 0V to 90% V <sub>DD</sub>
RSTB Pulse Width	T <sub>RST</sub>	10	-	-	μs	CLKIN = 50MHz
CLKIN cycle time	T <sub>cph</sub>	20	-	-	ns	
CLKIN pulse duty	T <sub>cwh</sub>	40	50	60	%	
VSD setup time	T <sub>vst</sub>	8	-	-	ns	
VSD hold time	T <sub>vhd</sub>	8	-	-	ns	
HSD setup time	T <sub>hst</sub>	8	-	-	ns	
HSD hold time	T <sub>hhd</sub>	8	-	-	ns	
Data set-up time	T <sub>dsu</sub>	8	-	-	ns	D0R[7:0], D1G[7:0], D2B[7:0] to CLKIN
Data hold time	T <sub>dhd</sub>	8	-	-	ns	D0R[7:0], D1G[7:0], D2B[7:0] to CLKIN
DE setup time	T <sub>esu</sub>	8	-	-	ns	
DE hold time	T <sub>ehd</sub>	8	-	-	ns	
Output stable time	T <sub>sst</sub>	-	-	6	μs	10%-90% target voltage C <sub>L</sub> = 120pf, R = 10kΩ

### Parallel 24-Bit RGB Mode Timing

Parameter	Symbol	Min	Typ	Max	Unit	Conditions
CLKIN Frequency	F <sub>clk</sub>	-	40	50	MHz	V <sub>DD</sub> = 3.0V ~ 3.6V
CLKIN time	T <sub>clk</sub>	20	25	-	Ns	
CLKIN Pulse Duty	T <sub>cwh</sub>	40	50	60	%	T <sub>clk</sub>
Time from HSD to Source Output	T <sub>hso</sub>	-	20	-	CLKIN	
Time from HSD to LD	T <sub>hld</sub>	-	20	-	CLKIN	
Time from HSD to STV	T <sub>hstv</sub>	-	2	-	CLKIN	
Time from HSD to CKV	T <sub>hckv</sub>	-	20	-	CLKIN	
Time from HSD to OEV	T <sub>hoev</sub>	-	4	-	CLKIN	
LD Pulse Width	T <sub>wld</sub>	-	10	-	CLKIN	
CKV Pulse Width	T <sub>wckv</sub>	-	66	-	CLKIN	
OEV Pulse Width	T <sub>woev</sub>	-	74	-	CLKIN	

### Vertical Input Timing

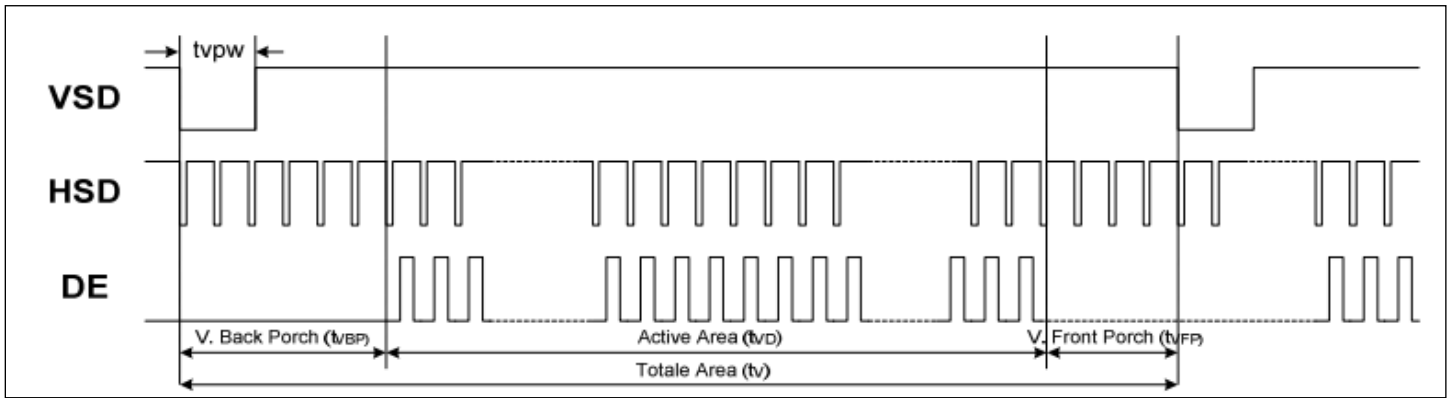

### Horizontal Input Timing

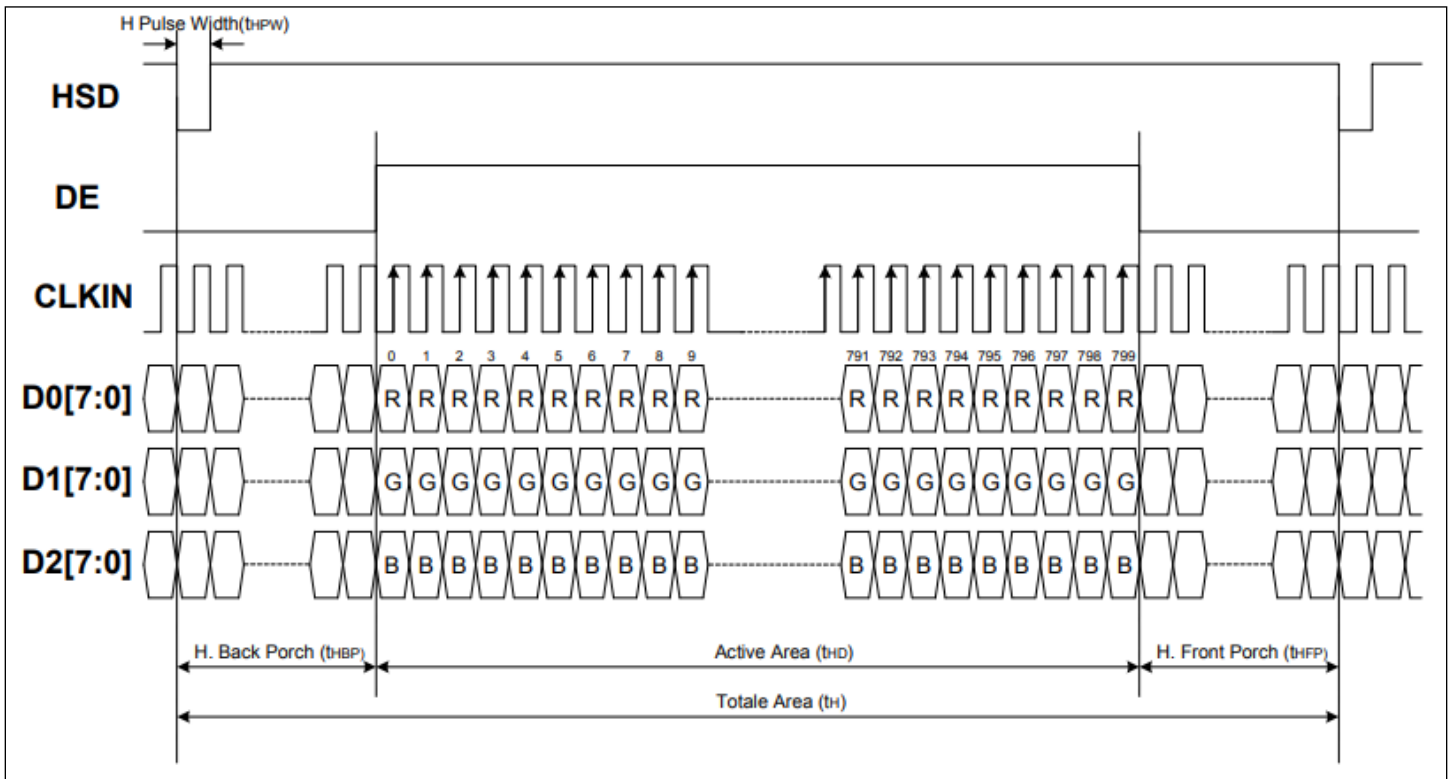

**Input Clock and Data Timing**

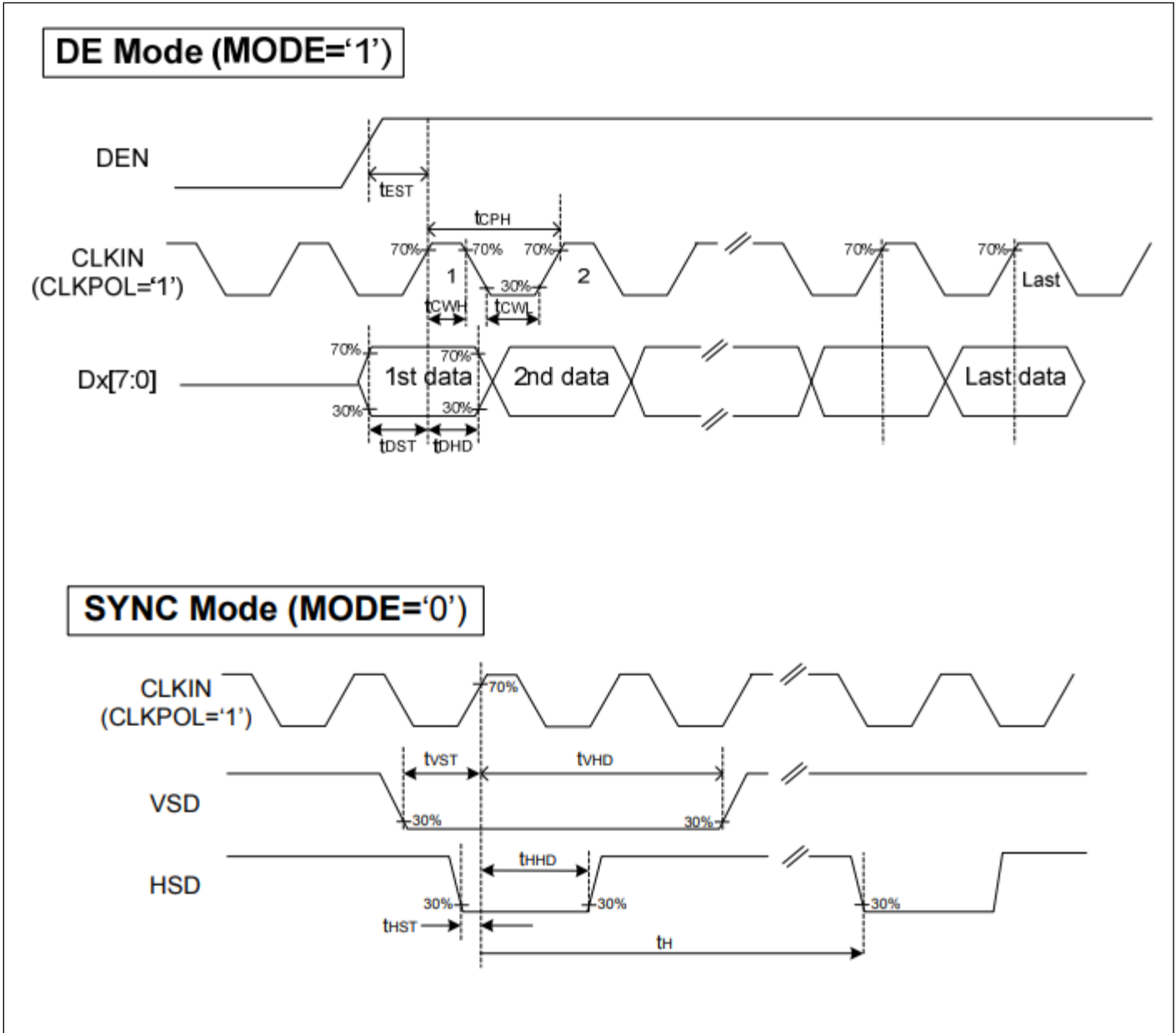

**Source Output Timing**

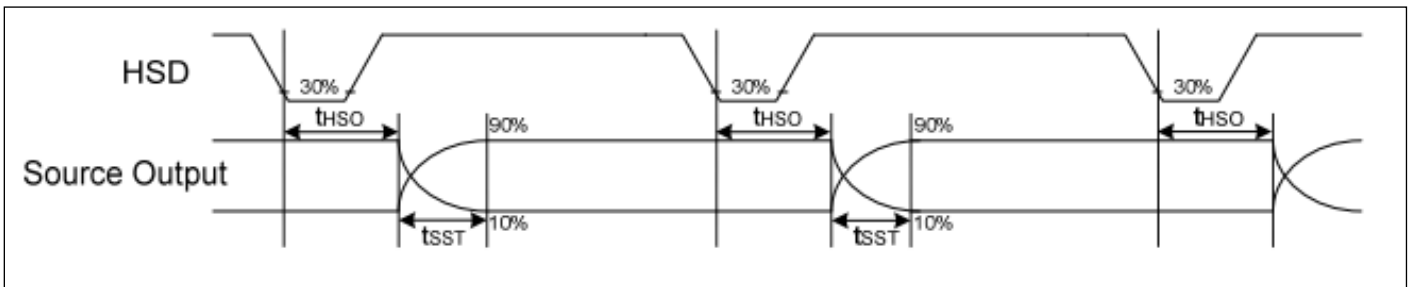

### Power ON/OFF Sequence

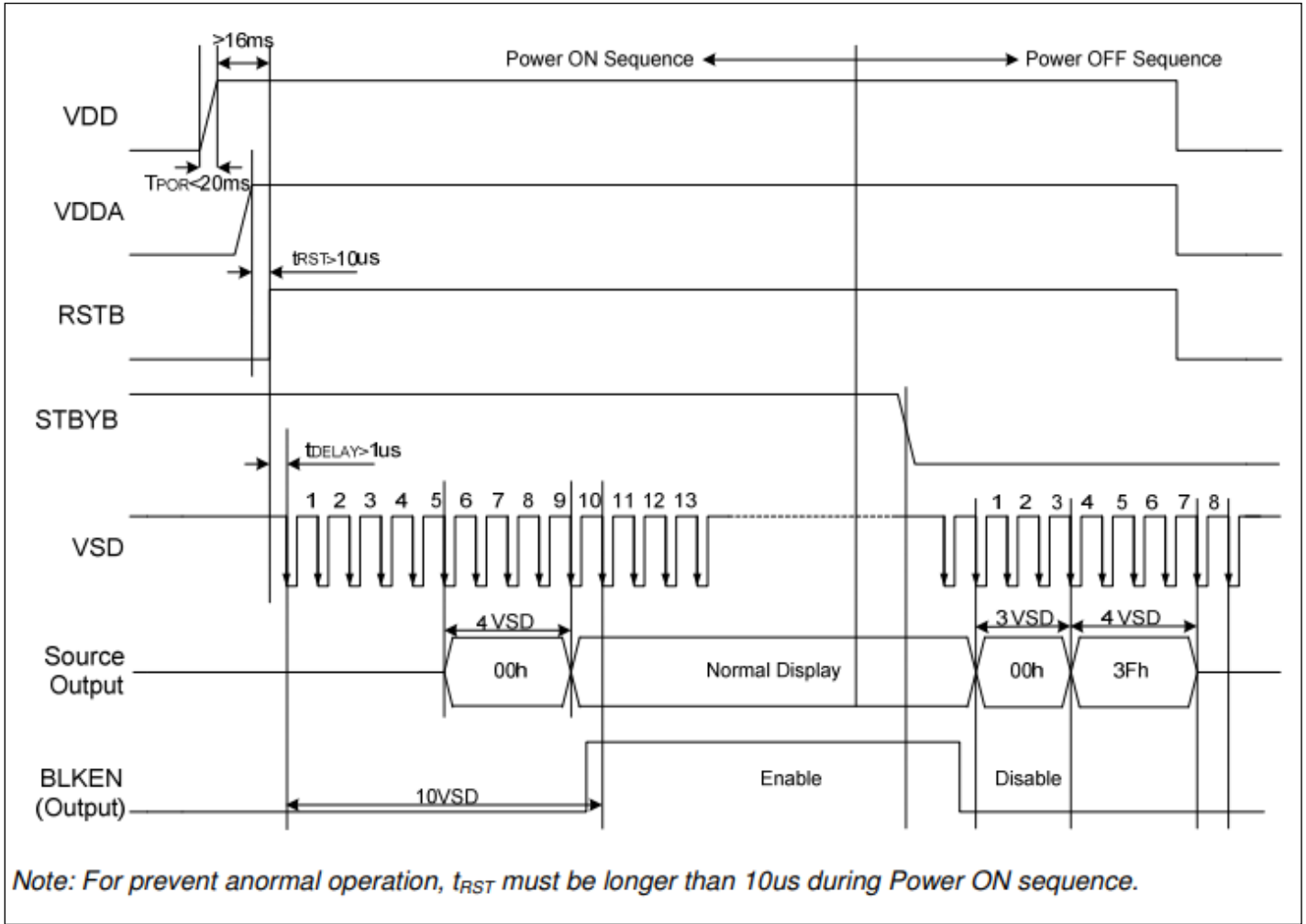

### Enter/Exit Standby Mode Sequence

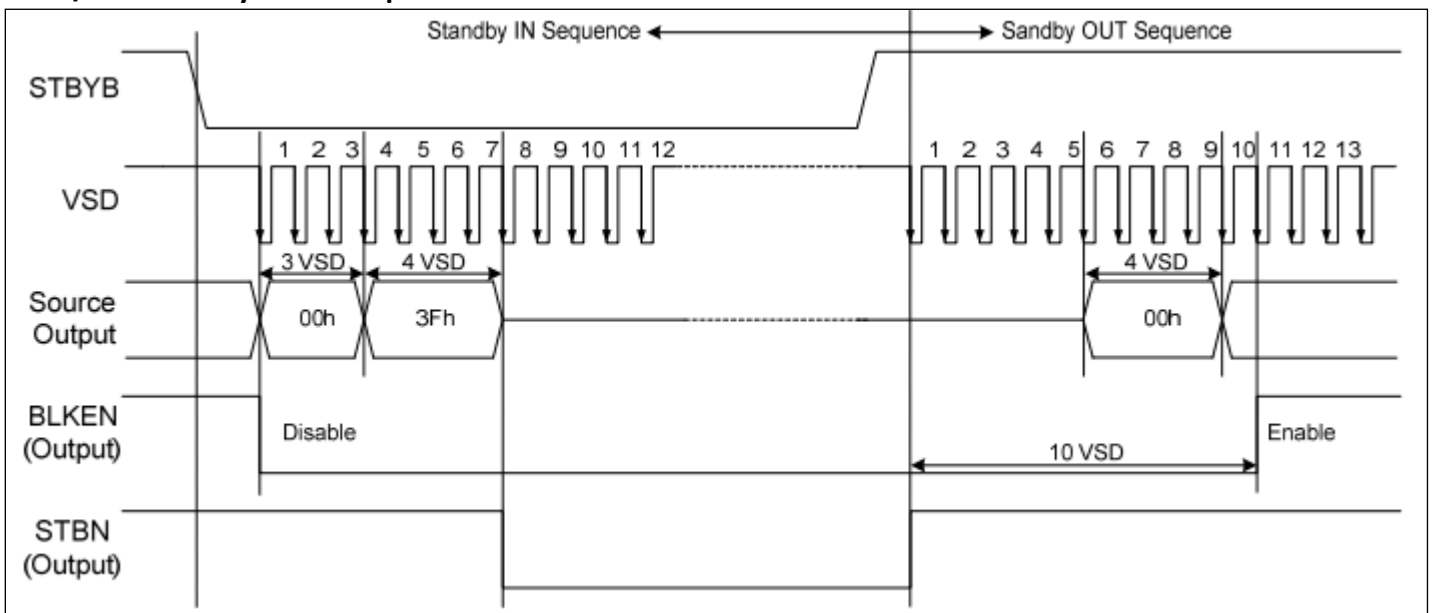

## Timing Characteristics – Capacitive Touch Panel

### Data Transfer Format

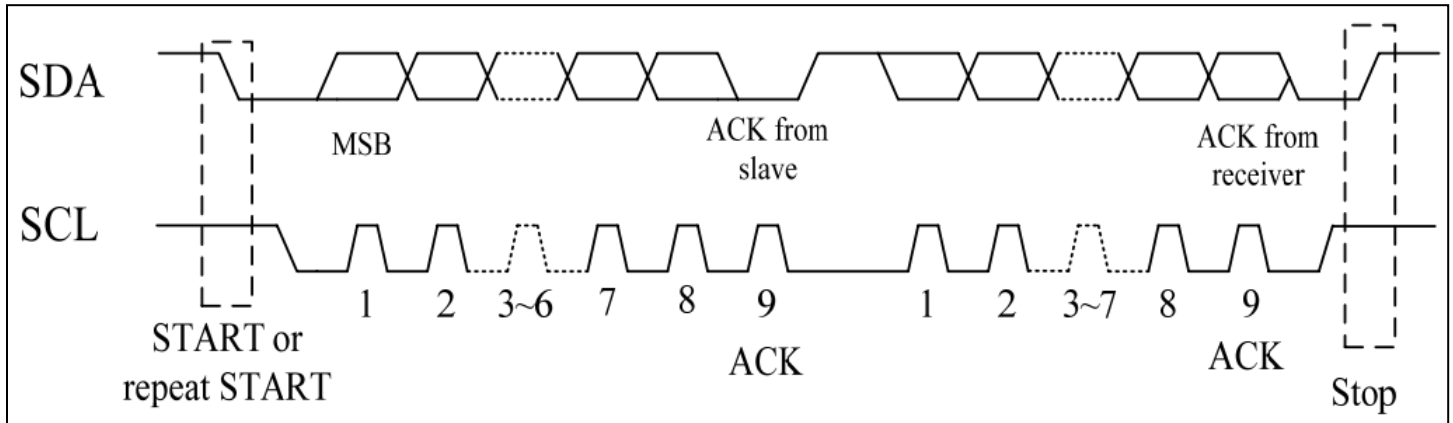

Parameter	Min	Max	Unit
SCL Frequency	0	400	KHz
Bus free time between a STOP & START condition	1.3	-	$\mu$ s
Hold time Repeated START condition	0.6	-	$\mu$ s
Data Setup Time	100	-	ns
Setup time for a repeated START condition	0.6	-	$\mu$ s
Setup time for a STOP condition	0.6	-	$\mu$ s

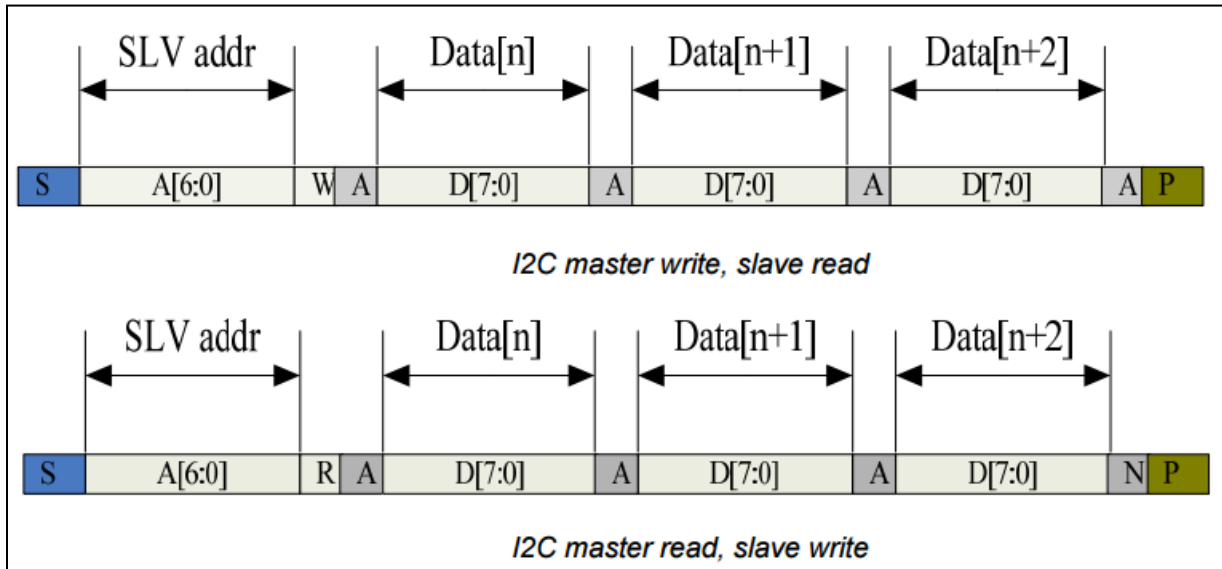

## Power ON/Reset Sequence

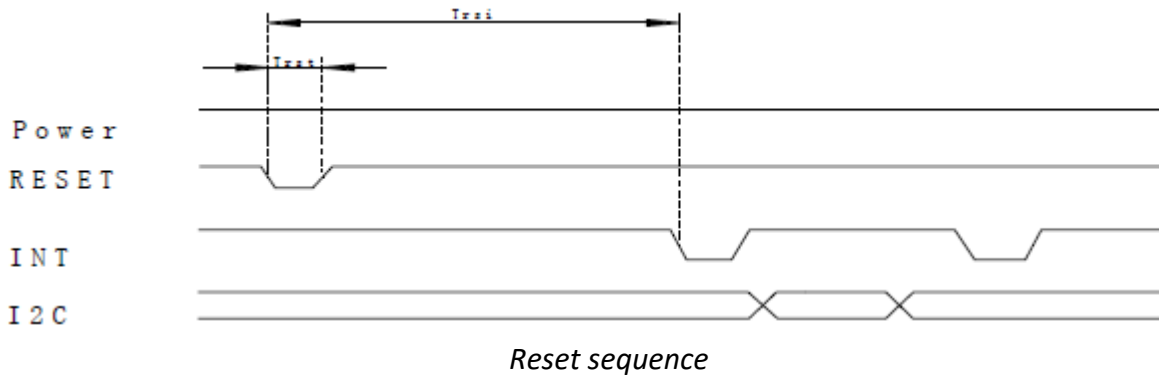
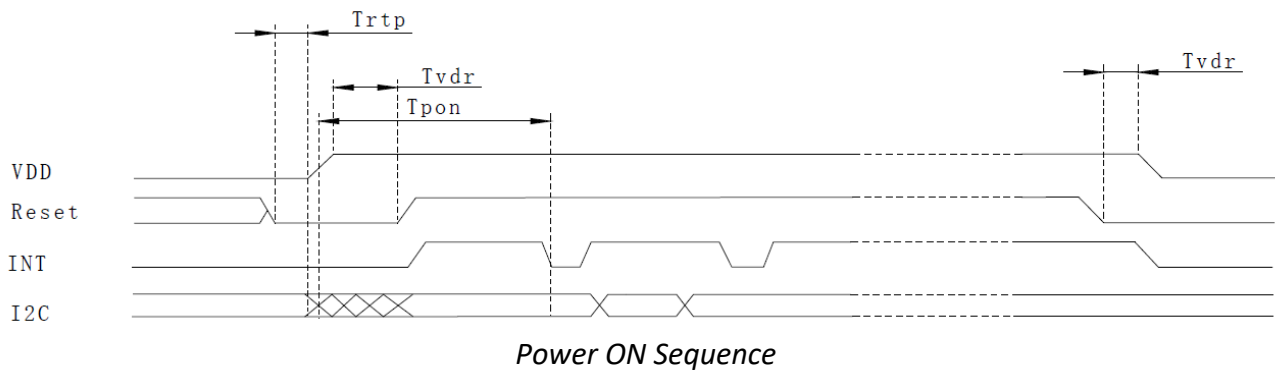
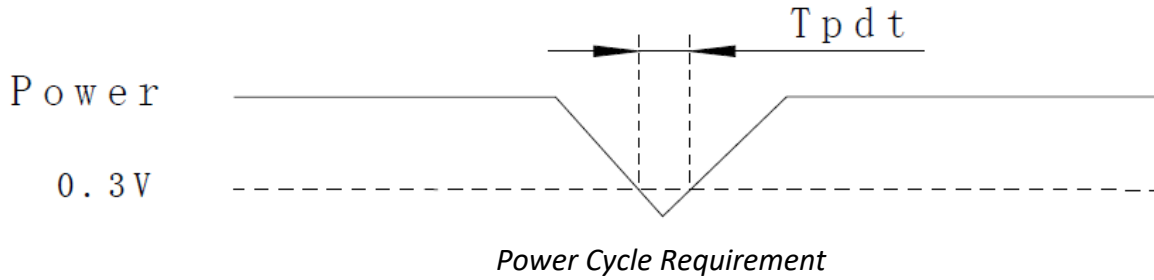
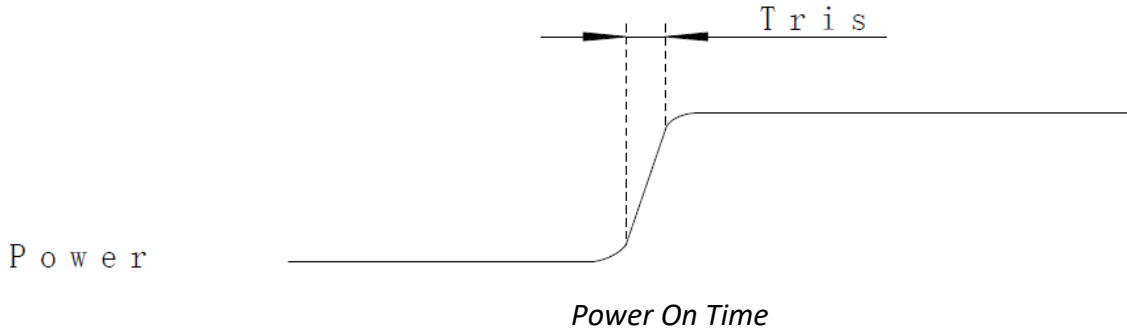

Parameter	Description	Min	Max	Unit
$T_{ris}$	Rise time from $0.1V_{DD}$ to $0.9V_{DD}$	-	5	ms
$T_{pd t}$	Time of the voltage of supply being below 0.3V	5	-	ms
$T_{rtp}$	Time of resetting to be low before powering on	100	-	$\mu s$
$T_{pon}$	Time to start reporting after power on	-	200	ms
$T_{vdr}^*$	Reset time after applying $V_{DD}$	1	-	ms
$T_{rsi}$	Time to start reporting after reset	-	200	ms
$T_{rst}^*$	Reset Time	1	-	ms

\*If Reset is tied to  $V_{CC}$  data corruption can occur.



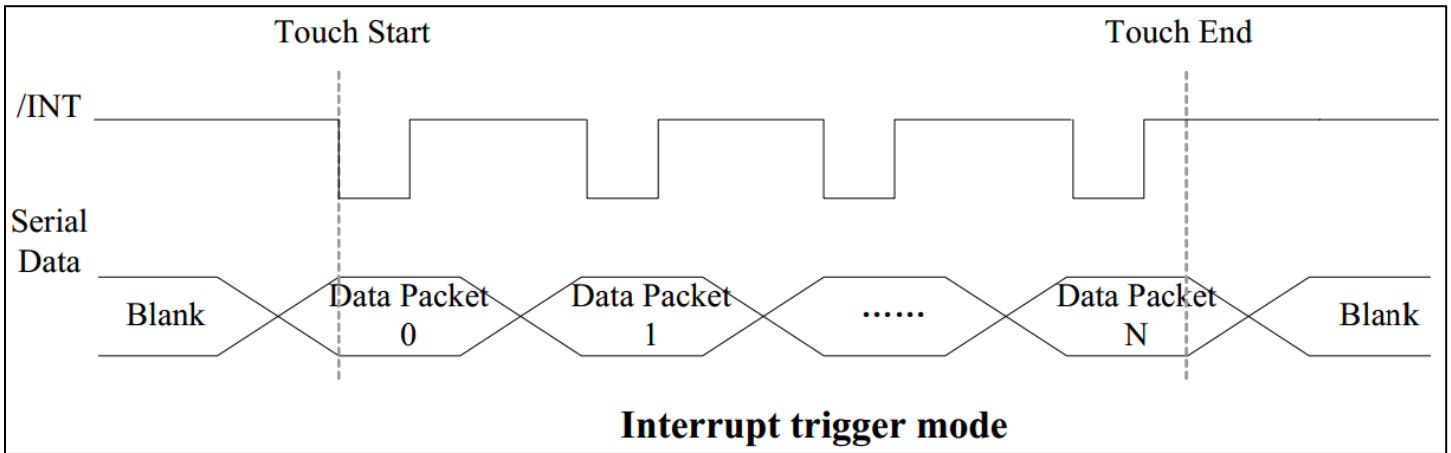

### Sample code to read touch data:

```

i2c_start();
i2c_tx(0x70);    //Slave Address (Write)
i2c_tx(0x00);    //Start reading address
i2c_stop();

i2c_start();
i2c_tx(0x71);    //Slave Address (Read)
for(i=0x00;i<0x1F;i++)
{touchdata_buffer[i] = i2c_rx(1);}
i2c_stop();

```

### Sample code to overwrite default register values:

```

i2c_start();
i2c_tx(0x70);    //Slave Address (Write)
i2c_tx(0xA4);    //ID_G_Mode
i2c_tx(0x01);    //Disable interrupt status to host
i2c_stop();

```

## Quality Information

Test Item	Content of Test	Test Condition	Note
High Temperature storage	Endurance test applying the high storage temperature for a long time.	+80°C , 96hrs	2
Low Temperature storage	Endurance test applying the low storage temperature for a long time.	-30°C , 96hrs	1,2
High Temperature Operation	Endurance test applying the electric stress (voltage & current) and the high thermal stress for a long time.	+70°C 96hrs	2
Low Temperature Operation	Endurance test applying the electric stress (voltage & current) and the low thermal stress for a long time.	-20°C , 96hrs	1,2
High Temperature / Humidity Operation	Endurance test applying the electric stress (voltage & current) and the high thermal with high humidity stress for a long time.	+60°C , 90-95% RH , 96hrs	1,2
Thermal Shock resistance	Endurance test applying the electric stress (voltage & current) during a cycle of low and high thermal stress.	-20°C,30min -> 25°C,5min - >70°C,30min = 1 cycle 10 cycles	
Vibration test	Endurance test applying vibration to simulate transportation and use.	10-55Hz , 1.5mm amplitude, 5G Acceleration, 60 sec in each of 3 directions X,Y,Z for 2 hours	3
Static electricity test	Endurance test applying electric static discharge.	Air: ±8kV ; Contact: ±4kV For 5 times each.	

**Note 1:** No condensation to be observed.

**Note 2:** Conducted after 4 hours of storage at 25°C, 0%RH.

**Note 3:** Test performed on product itself, not inside a container.