

NHD-C0220BiZ-FSW-FBW-3V3M

COG (Chip-On-Glass) Character Liquid Crystal Display Module

NHD-	Newhaven Display
C0220-	COG, 2 Lines x 20 Characters
BiZ-	Model, I ² C interface
F-	Transflective
SW-	Side White LED Backlight
F-	FSTN (+)
B-	6:00 Optimal View
W-	Wide Temperature
3V3-	3.3V LCD
M-	Mounting Holes
	RoHS Compliant

Newhaven Display International, Inc.

2511 Technology Drive, Suite 101

Elgin IL, 60124

Ph: 847-844-8795

Fax: 847-844-8796

www.newhavendisplay.com

nhtech@newhavendisplay.com

nhsales@newhavendisplay.com

Document Revision History

Revision	Date	Description	Changed by
0	7/8/09	Initial Release	
1	10/9/09	Updated Electrical Characteristic	MC
2	11/20/09	Updated backlight supply current	MC
3	5/27/11	Display character address code updated	AK
4	6/23/14	Mechanical Drawing, Electrical & Optical characteristics updated	ML
5	3/18/19	Mechanical Drawing & Electrical Characteristics Updated	SB
6	6/24/19	Added PCB Footprint Drawing	AS
7	9/22/20	Updated Drive Conditions in Electrical Characteristics Table	AS
8	10/23/20	Updated Symbol for LCD Supply Voltage	AS

Functions and Features

- 2 lines x 20 characters
- Built-in ST7036i controller with I²C interface
- 3.3V power supply
- 1/16 duty, 1/5 bias
- Built-in DC supply for VLCD (requires 2 external capacitors)

A
B
C
D
E
F

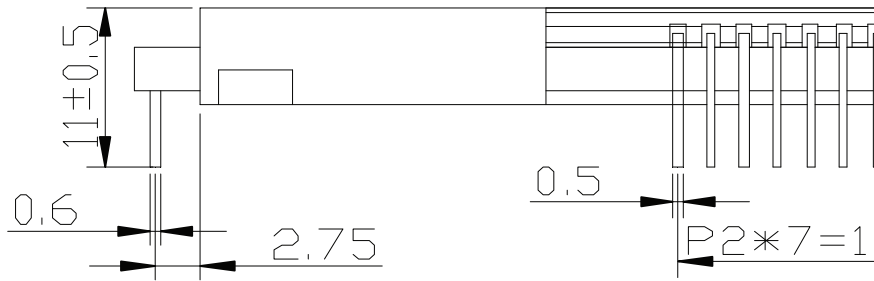
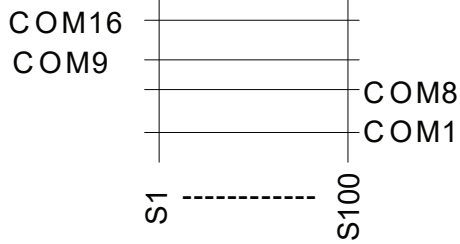
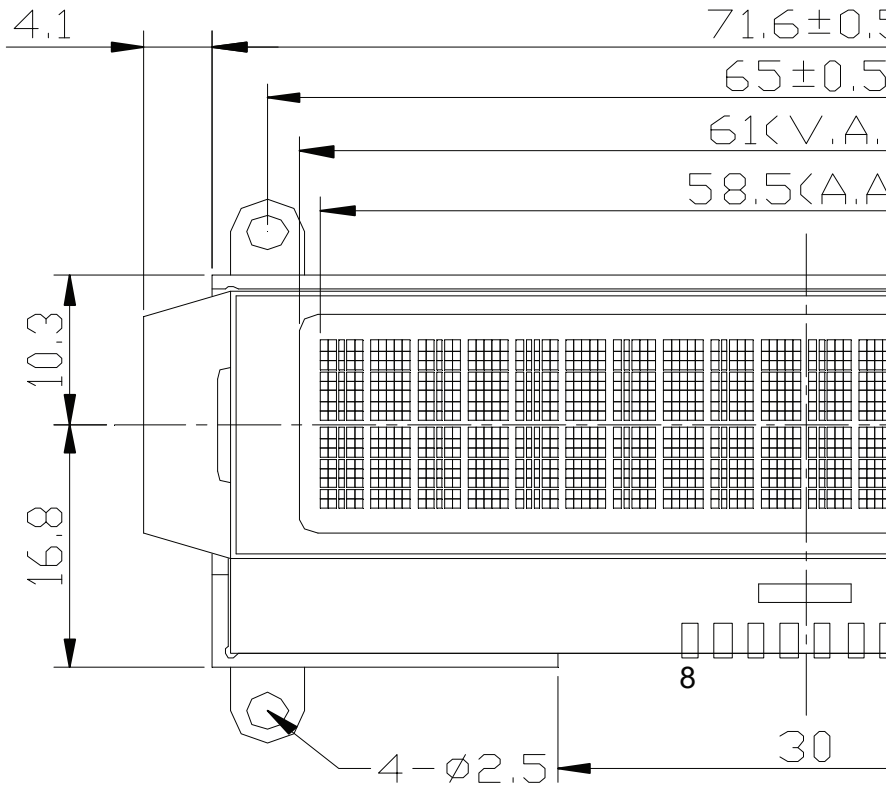
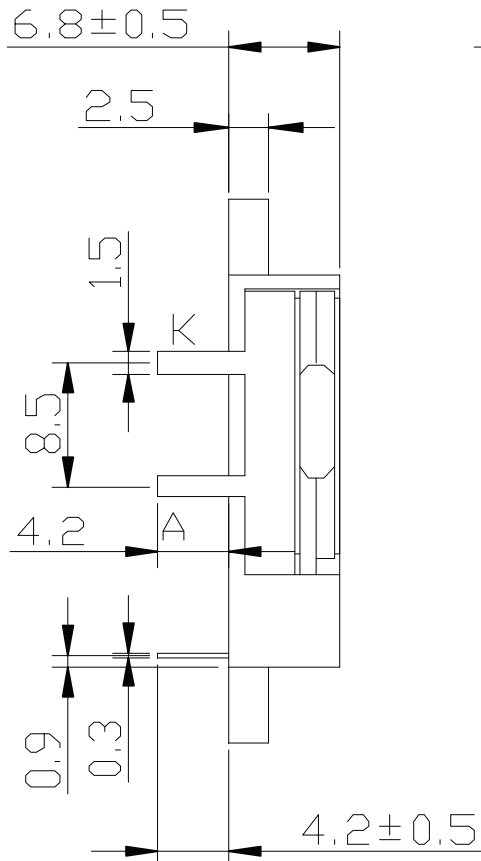

Notes:

- 1. Driver: 1/16 Duty, 1/5 Bias
- 2. Voltage: 3.3V VDD, 5.5V VLCD
- 3. Display Mode: FSTN Positive / Transflective
- 4. Optimal View: 6:00
- 5. Backlight: LED
- 6. Driver IC: ST7036i I2C Interface

A Recommended PCB Footprint

B

C

D

E

F

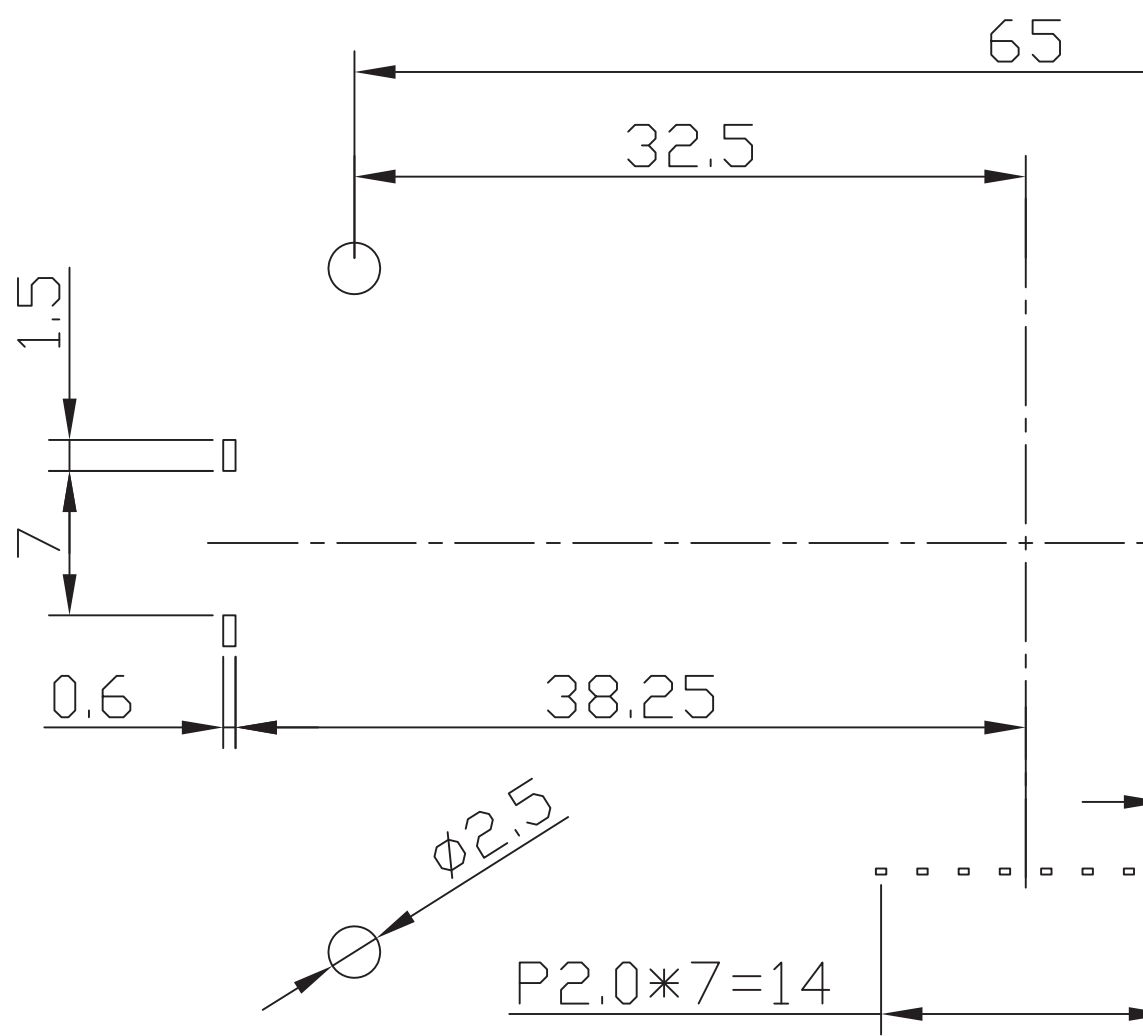

Applicable Displays:
1) NHD-C0220BiZ-FSW-FBW-3V3M

1

2

3

4

↑

Pin Description and Wiring Diagram

Pin No.	Symbol	External Connection	Function Description
1	RST	MPU	Active LOW Reset signal
2	SCL	MPU	Serial Clock signal (requires pull-up resistor)
3	SDA	MPU	Serial Data signal (requires pull-up resistor)
4	V _{SS}	Power Supply	Ground
5	V _{DD}	Power Supply	Supply Voltage for logic (+3.3V)
6	V _{OUT}	CAP	Voltage booster circuit – Connect 0.47μF~2.2μF cap to V _{SS} or V _{DD}
7	C1+	CAP	Connect 1μF cap to PIN8
8	C1-	CAP	Connect 1μF cap to PIN7

Recommended LCD connector: N/A, solder directly into PCB

Backlight connector: 8.5mm pitch pins, solder directly into PCB **Mates with:** ---

Recommended Breakout Board: [NHD-PCB40](#)

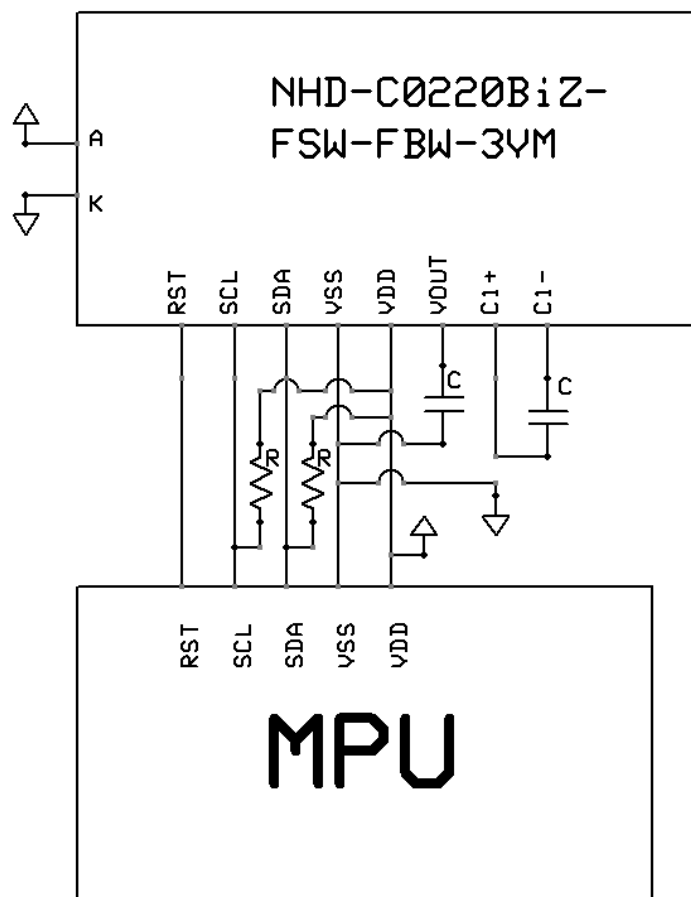

Capacitance 0.47μF~2.2μF

Recommended value = 1μF

Recommended Resistor: 10KΩ

Electrical Characteristics

Item	Symbol	Condition	Min.	Typ.	Max.	Unit
Operating Temperature Range	T _{OP}	Absolute Max	-20	-	+70	°C
Storage Temperature Range	T _{ST}	Absolute Max	-30	-	+80	°C
Supply Voltage	V _{DD}	-	3.0	3.3	3.6	V
Supply Current	I _{DD}	V _{DD} = 3.3V	0.2	0.5	1.5	mA
Supply for LCD (contrast)	V _{LCD}	V ₀ -V _{SS} , T _{OP} = 25°C	5.3	5.5	5.7	V
"H" Level input	V _{IH}	-	0.7 * V _{DD}	-	V _{DD}	V
"L" Level input	V _{IL}	-	V _{SS}	-	0.2 * V _{DD}	V
"H" Level output	V _{OH}	-	0.7 * V _{DD}	-	V _{DD}	V
"L" Level output	V _{OL}	-	V _{SS}	-	0.8	V
Backlight Supply Current – White	I _{LED}	-	-	30	35	mA
Backlight Supply Voltage – White*	V _{LED}	I _{LED} = 30 mA	2.8	3.0	3.3	V

*The LED of the backlight is driven by current drain; drive voltage is for reference only. Drive voltage must be selected to ensure backlight current drain is below MAX level stated.

Optical Characteristics

Item	Symbol	Condition	Min.	Typ.	Max.	Unit
Optimal Viewing Angles	Top	CR ≥ 2	-	40	-	°
	Bottom		-	60	-	°
	Left		-	60	-	°
	Right		-	60	-	°
Contrast Ratio	CR	-	2	5	-	-
Response Time	Rise	T _{OP} = 25°C	-	150	250	ms
	Fall		-	200	300	ms

Controller Information

Built-in ST7036i controller.

Please download specification at http://www.newhavendisplay.com/app_notes/ST7036.pdf

DDRAM Address

1	2	3	4	5	6	7	8	9	10	11	12	13	14	15	16	17	18	19	20
00	01	02	03	04	05	06	07	08	09	0A	0B	0C	0D	0E	0F	10	11	12	13
40	41	42	43	44	45	46	47	48	49	4A	4B	4C	4D	4E	4F	50	51	52	53

Slave Address = 0x78

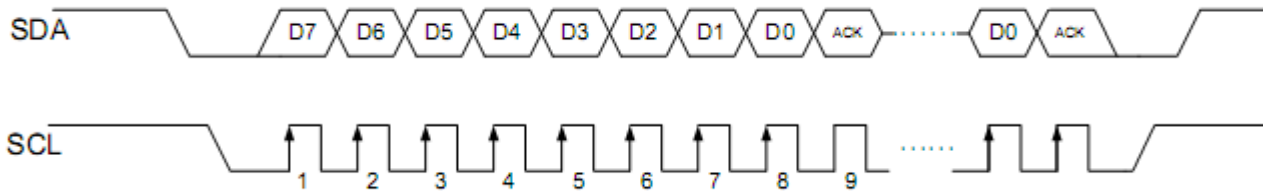
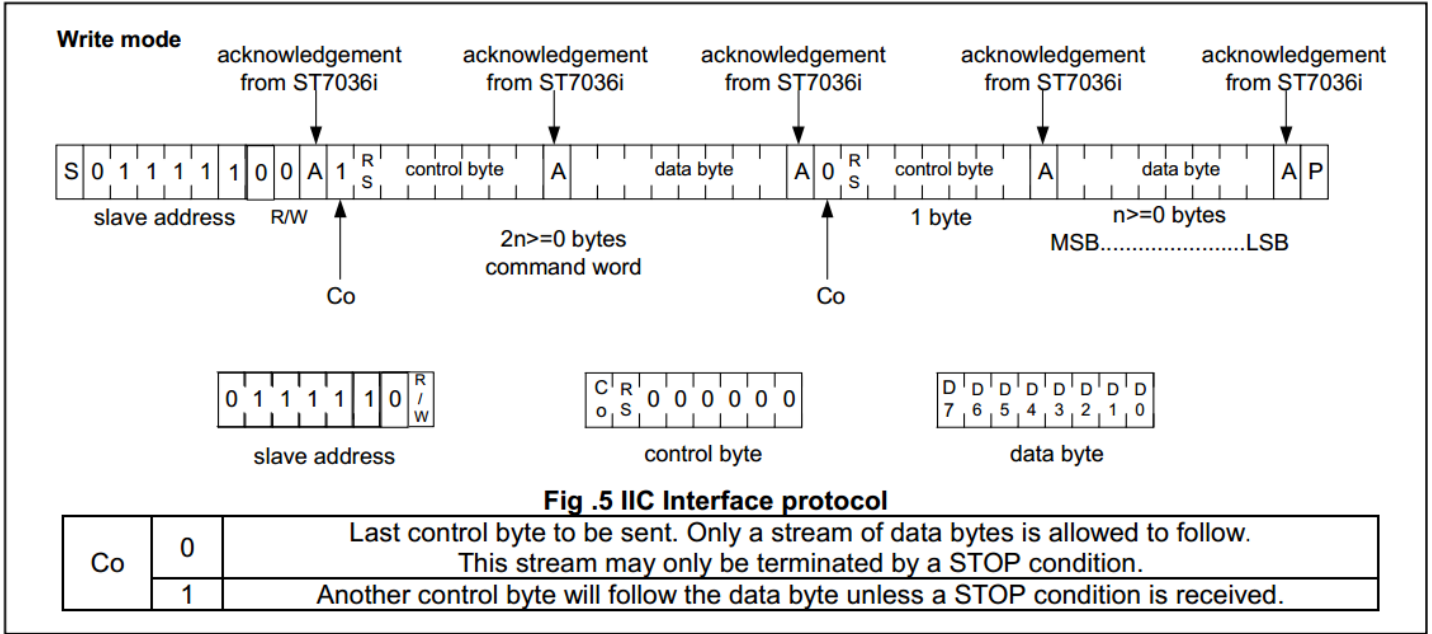

Table of Commands

Instruction	Instruction Code										Description	
	RS	R/W	DB7	DB6	DB5	DB4	DB3	DB2	DB1	DB0		
Clear Display	0	0	0	0	0	0	0	0	0	0	1	Write "20H" to DDRAM. and set DDRAM address to "00H" from AC
Return Home	0	0	0	0	0	0	0	0	0	1	x	Set DDRAM address to "00H" from AC and return cursor to its original position if shifted. The contents of DDRAM are not changed.
Entry Mode Set	0	0	0	0	0	0	0	0	1	I/D	S	Sets cursor move direction and specifies display shift. These operations are performed during data write and read.
Display ON/OFF	0	0	0	0	0	0	0	1	D	C	B	D=1:entire display on C=1:cursor on B=1:cursor position on
Function Set	0	0	0	0	1	DL	N	DH	IS2	IS1		DL: interface data is 8/4 bits N: number of line is 2/1 DH: double height font IS[2:1]: instruction table select
Set DDRAM Address	0	0	1	AC6	AC5	AC4	AC3	AC2	AC1	AC0		Set DDRAM address in address counter
Read Busy Flag and Address	0	1	BF	AC6	AC5	AC4	AC3	AC2	AC1	AC0		Whether during internal operation or not can be known by reading BF. The contents of address counter can also be read.
Write Data to RAM	1	0	D7	D6	D5	D4	D3	D2	D1	D0		Write data into internal RAM (DDRAM/CGRAM/ICONRAM)
Read Data from RAM	1	1	D7	D6	D5	D4	D3	D2	D1	D0		Read data from internal RAM (DDRAM/CGRAM/ICONRAM)

Instruction table 0(IS[2:1]=[0,0])

Cursor or Display Shift	0	0	0	0	0	1	S/C	R/L	X	X	S/C and R/L: Set cursor moving and display shift control bit, and the direction, without changing DDRAM data.
Set CGRAM	0	0	0	1	AC5	AC4	AC3	AC2	AC1	AC0	Set CGRAM address in address counter

Instruction table 1(IS[2:1]=[0,1])

Bias Set	0	0	0	0	0	1	BS	1	0	FX	BS=1:1/4 bias BS=0:1/5 bias FX: fixed on high in 3-line application and fixed on low in other applications.
Set ICON Address	0	0	0	1	0	0	AC3	AC2	AC1	AC0	Set ICON address in address counter.
Power/ICON Control/ Contrast Set	0	0	0	1	0	1	Ion	Bon	C5	C4	Ion: ICON display on/off Bon: set booster circuit on/off C5,C4: Contrast set for internal follower mode.
Follower Control	0	0	0	1	1	0	Fon	Rab2	Rab1	Rab0	Fon: set follower circuit on/off Rab2~0: select follower amplified ratio.
Contrast Set	0	0	0	1	1	1	C3	C2	C1	C0	Contrast set for internal follower mode.

Instruction table 2(IS[2:1]=[1,0])

Double Height Position Select	0	0	0	0	0	1	UD	X	x	x	UD: Double height position select
Reserved	0	0	0	1	X	X	X	X	X	X	Do not use (reserved for test)

Timing Characteristics

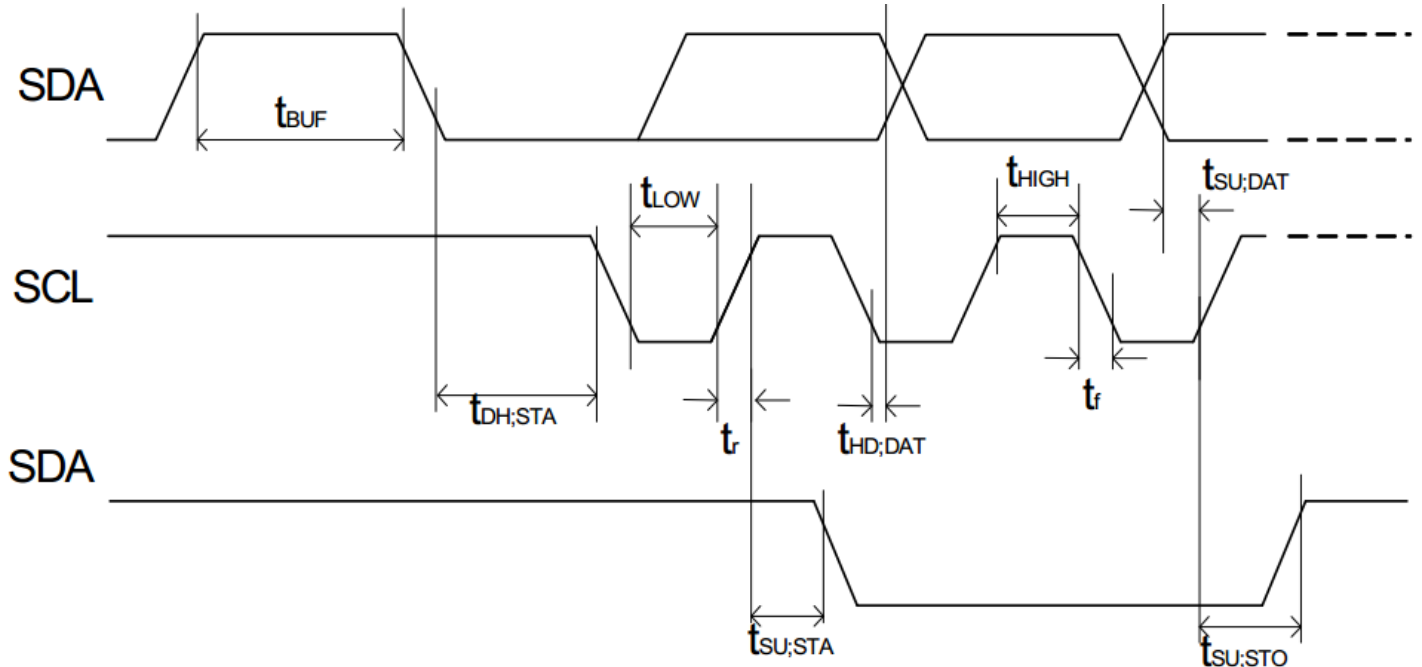

Item	Signal	Symbol	Condition	VDD=2.7 to 4.5V Rating		VDD=4.5 to 5.5V Rating		Units
				Min.	Max.	Min.	Max.	
SCL clock frequency	SCL	f_{SCLK}	—	DC	300K	DC	400	kHz
SCL clock low period		t_{LOW}	—	2.5	—	1.3	—	μ s
SCL clock high period		t_{HIGH}	—	0.6	—	0.6	—	
Data set-up time	SDA	$t_{SU,DAT}$	—	1800	—	700	—	ns
Data hold time		$t_{HD,DAT}$	—	0	—	0	0.5	μ s
SCL,SDA rise time	SCL, SDA	t_r	—	$20+0.1C_b$	300	$20+0.1C_b$	300	ns
SCL,SDA fall time		t_r	—	$20+0.1C_b$	300	$20+0.1C_b$	300	
Capacitive load represent by each bus line		C_b	—	—	400	—	400	pf
Setup time for a repeated START condition	SDA	$t_{SU,STA}$	—	0.6	—	0.6	—	μ s
Start condition hold time		$t_{HD,STA}$	—	1.8	—	1.0	—	μ s
Setup time for STOP condition		$t_{SU,STO}$	—	0.6	—	0.6	—	μ s
Bus free time between a Stop and START condition	SCL	t_{BUF}	—	1.3	—	1.3	—	μ s

Built-in Font Table (OPR1 = 0, OPR2 = 0)

b7-b4 b3-b0	0000	0001	0010	0011	0100	0101	0110	0111	1000	1001	1010	1011	1100	1101	1110	1111
0000	█	█	█	█	█	█	█	█	█	█	█	█	█	█	█	█
0001	█	█	█	█	█	█	█	█	█	█	█	█	█	█	█	█
0010	█	█	█	█	█	█	█	█	█	█	█	█	█	█	█	█
0011	█	█	█	█	█	█	█	█	█	█	█	█	█	█	█	█
0100	█	█	█	█	█	█	█	█	█	█	█	█	█	█	█	█
0101	█	█	█	█	█	█	█	█	█	█	█	█	█	█	█	█
0110	█	█	█	█	█	█	█	█	█	█	█	█	█	█	█	█
0111	█	█	█	█	█	█	█	█	█	█	█	█	█	█	█	█
1000	█	█	█	█	█	█	█	█	█	█	█	█	█	█	█	█
1001	█	█	█	█	█	█	█	█	█	█	█	█	█	█	█	█
1010	█	█	█	█	█	█	█	█	█	█	█	█	█	█	█	█
1011	█	█	█	█	█	█	█	█	█	█	█	█	█	█	█	█
1100	█	█	█	█	█	█	█	█	█	█	█	█	█	█	█	█
1101	█	█	█	█	█	█	█	█	█	█	█	█	█	█	█	█
1110	█	█	█	█	█	█	█	█	█	█	█	█	█	█	█	█
1111	█	█	█	█	█	█	█	█	█	█	█	█	█	█	█	█

Example Initialization Program

```

/*****
*           Initialization For ST7036i           *
*****/
void init_LCD()
{
I2C_Start();
I2C_out(Slave); //Slave=0x78
I2C_out(Comsend); //Comsend = 0x00
I2C_out(0x38);
delay(10);
I2C_out(0x39);
delay(10);
I2C_out(0x14);
I2C_out(0x78);
I2C_out(0x5E);
I2C_out(0x6D);
I2C_out(0x0C);
I2C_out(0x01);
I2C_out(0x06);
delay(10);
I2C_Stop();
}
/*****/

/*****
*           Output command or data via I2C           *
*****/
void I2C_out(unsigned char j) //I2C Output
{
    int n;
    unsigned char d;
    d=j;
    for(n=0;n<8;n++){
        if((d&0x80)==0x80)
            SDA=1;
        else
            SDA=0;
        d=(d<<1);
        SCL = 0;
        SCL = 1;
        SCL = 0;
    }
    SCL = 1;
    while(SDA==1){
        SCL=0;
        SCL=1;
    }
    SCL=0;
}
/*****/

```

```

/*****
*           I2C Start                               *
*****/
void I2C_Start(void)
{
    SCL=1;
    SDA=1;
    SDA=0;
    SCL=0;
}
/*****/

/*****
*           I2C Stop                               *
*****/
void I2C_Stop(void)
{
    SDA=0;
    SCL=0;
    SCL=1;
    SDA=1;
}
/*****/

/*****
*           Send string of ASCII data to LCD       *
*****/
void Show(unsigned char *text)
{
    int n,d;
    d=0x00;
    I2C_Start();
    I2C_out(Slave); //Slave=0x78
    I2C_out(Datasend); //Datasend=0x40
    for(n=0;n<20;n++){
        I2C_out(*text);
        ++text;
    }
    I2C_Stop();
}
/*****/
/*****/
/*****/

```

Quality Information

Test Item	Content of Test	Test Condition	Note
High Temperature storage	Endurance test applying the high storage temperature for a long time.	+80°C, 48hrs	2
Low Temperature storage	Endurance test applying the low storage temperature for a long time.	-30°C, 48hrs	1,2
High Temperature Operation	Endurance test applying the electric stress (voltage & current) and the high thermal stress for a long time.	+70°C, 48hrs	2
Low Temperature Operation	Endurance test applying the electric stress (voltage & current) and the low thermal stress for a long time.	-20°C, 48hrs	1,2
High Temperature / Humidity Operation	Endurance test applying the electric stress (voltage & current) and the high thermal with high humidity stress for a long time.	+60°C, 90% RH, 48hrs	1,2
Thermal Shock resistance	Endurance test applying the electric stress (voltage & current) during a cycle of low and high thermal stress.	-20°C,30min -> 25°C,5min -> 70°C,30min = 1 cycle 10 cycles	
Vibration test	Endurance test applying vibration to simulate transportation and use.	10-55Hz, 15mm Amplitude. 60 sec in each of 3 directions X, Y, Z For 15 minutes	3
Static electricity test	Endurance test applying electric static discharge.	VS=800V, RS=1.5kΩ, CS=100pF One time	

Note 1: No condensation to be observed.

Note 2: Conducted after 4 hours of storage at 25°C, 0%RH.

Note 3: Test performed on product itself, not inside a container.

Precautions for using LCDs/LCMs

See Precautions at www.newhavendisplay.com/specs/precautions.pdf

Warranty Information

See Terms & Conditions at http://www.newhavendisplay.com/index.php?main_page=terms

X-ON Electronics

Largest Supplier of Electrical and Electronic Components

Click to view similar products for [LCD Character Display Modules & Accessories](#) category:

Click to view products by [Newhaven Display](#) manufacturer:

Other Similar products are found below :

[HG9Z-AC501](#) [HG9Z-SCI25B](#) [LCM-S01602DTRA-3](#) [HG9Z-XC213](#) [EA FL-10P](#) [MDLS-161612-G-LV-LED4G](#) [MDLS-81809-LV-GLED4G](#)
[MDLS-20265-LV-GLED4G](#) [NMTC-S16205DFYHSAY-22](#) [NHD-0420AZ-FSW-GBW-33V33-0](#) [CM1644-SGR1](#) [162A BC BW](#) [LCM-](#)
[S02002DSM-Y](#) [162D BA BC](#) [HDM24216H-2-P9XS](#) [DEM 16207 SYH-PY](#) [RC0802A1-LLG-JWVE](#) [RC0802A1-LLR-JWVE](#) [RC0802A-](#)
[TIW-ESV](#) [RC1202A-BIY-CSX](#) [RC1202A-BIY-ESX](#) [RC1602A-BIW-CSV](#) [RC1602A-YHW-CSV](#) [RC1602B-GHY-CSXD](#) [RC1602B-TIW-](#)
[CSV](#) [RC1602B-YHY-CSVD](#) [RC1602D-GHY-ESX](#) [RC2002A2-LLB-JSVE](#) [RC2002A-GHG-CSV](#) [RC2004A-BIW-ESX](#) [RC2004A-GHW-](#)
[CSV](#) [RC2004A-LLB-JSVE](#) [RC2004A-LLH-JSV](#) [RC2004A-LLR-JSVE](#) [DEM 08171 SYH-LY](#) [DEM 08172 SYH-PY](#) [DEM16101SYH-LY](#)
[DEM 16209 SBH-PW-N](#) [DEM 16210 SGH](#) [DEM 16214 FGH-PW](#) [DEM 16216 FDH-P\(RGB\)-N](#) [DEM16216SYH-LY](#) [DEM 16217 SYH-PY](#)
[DEM 16221 SYH](#) [DEM 16221 SYH \(FFCF/TR\)/V](#) [DEM 16227 FGH-PW](#) [DEM 16227 SBH-PW-N](#) [DEM 16227 SYH-LY](#) [DEM 20231 SYH-](#)
[PY-CYR22](#) [DEM 20232 SBH-PW-N](#)