

74AUP1Z125

Low-power X-tal driver with enable and internal resistor;
3-state

Rev. 6 — 11 December 2020

Product data sheet

1. General description

The 74AUP1Z125 is a crystal driver with enable, internal resistor and 3-state output. When not in use the $\overline{\text{EN}}$ input can be driven HIGH, putting the device in a low power disable mode with X1 pulled HIGH via R_{PU} , X2 set LOW and Y in the high impedance OFF-state. In disable mode the output Y assumes the high impedance OFF-state. Schmitt trigger action on the EN input makes the circuit tolerant to slower input rise and fall times across the entire V_{CC} range from 0.8 V to 3.6 V. Schmitt-trigger action at all inputs makes the circuit tolerant of slower input rise and fall times.

2. Features and benefits

- Wide supply voltage range from 0.8 V to 3.6 V
- High noise immunity
- ESD protection:
 - HBM JESD22-A114F Class 3A exceeds 5000 V
 - MM JESD22-A115-A exceeds 200 V
 - CDM JESD22-C101E exceeds 1000 V
- Latch-up performance exceeds 100 mA per JESD78B Class II
- Overvoltage tolerant inputs to 3.6 V
- Low noise overshoot and undershoot < 10 % of V_{CC}
- I_{OFF} circuitry provides partial power-down mode operation at output Y
- Multiple package options
- Specified from -40 °C to +85 °C and -40 °C to +125 °C

3. Ordering information

Table 1. Ordering information

Type number	Package			
	Temperature range	Name	Description	Version
74AUP1Z125GW	-40 °C to +125 °C	SC-88	plastic surface-mounted package; 6 leads	SOT363
74AUP1Z125GM	-40 °C to +125 °C	XSON6	plastic extremely thin small outline package; no leads; 6 terminals; body 1 × 1.45 × 0.5 mm	SOT886
74AUP1Z125GN	-40 °C to +125 °C	XSON6	extremely thin small outline package; no leads; 6 terminals; body 0.9 × 1.0 × 0.35 mm	SOT1115
74AUP1Z125GS	-40 °C to +125 °C	XSON6	extremely thin small outline package; no leads; 6 terminals; body 1.0 × 1.0 × 0.35 mm	SOT1202

4. Marking

Table 2. Marking

Type number	Marking code [1]
74AUP1Z125GW	55
74AUP1Z125GM	55
74AUP1Z125GN	55
74AUP1Z125GS	55

[1] The pin 1 indicator is located on the lower left corner of the device, below the marking code.

5. Functional diagram

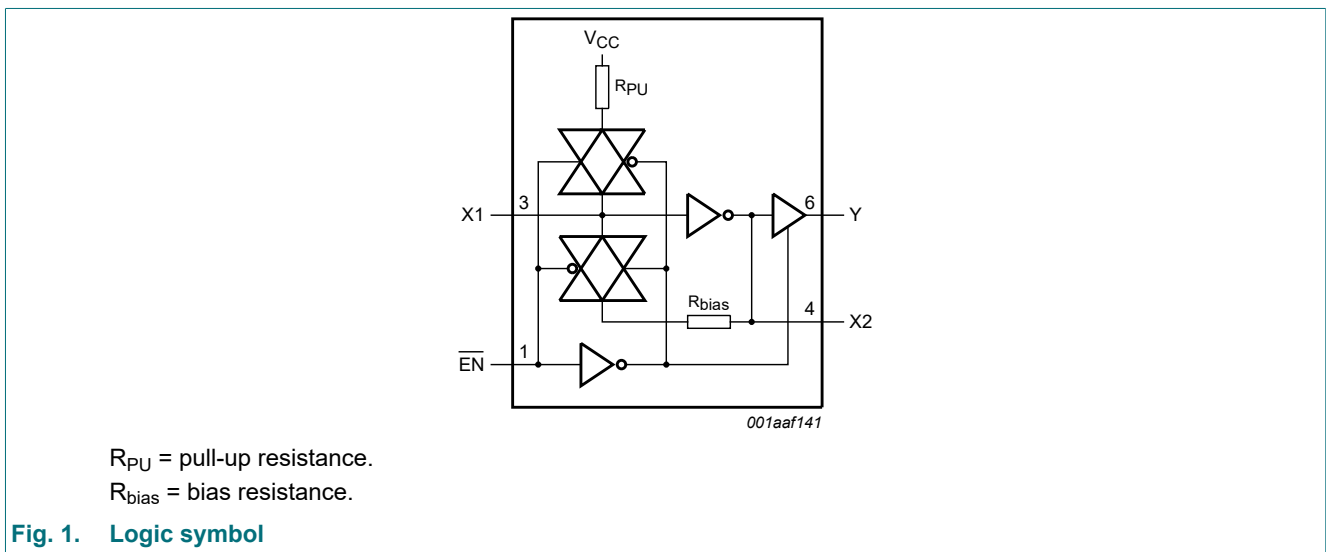

6. Pinning information

6.1. Pinning

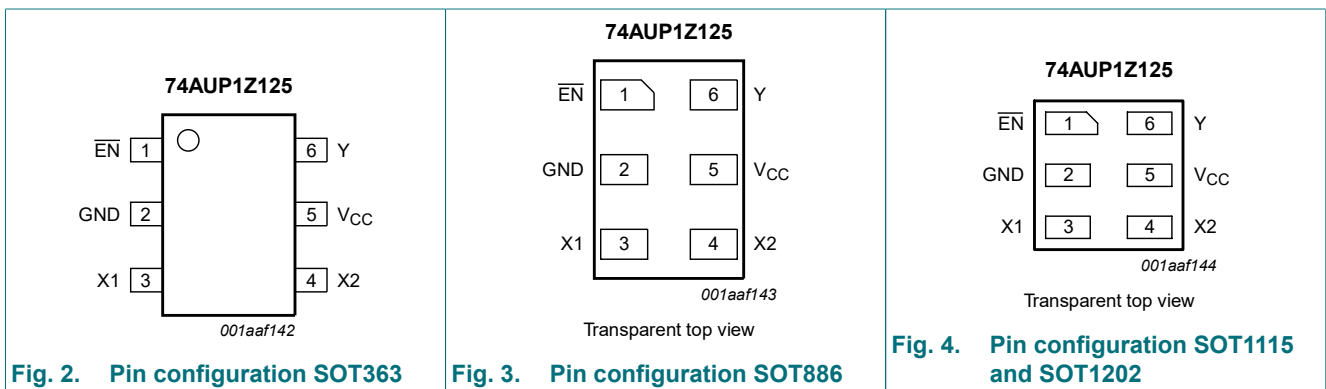

6.2. Pin description

Table 3. Pin description

Symbol	Pin	Description
EN	1	enable input (active LOW)
GND	2	ground (0 V)
X1	3	data input
X2	4	unbuffered output
V _{CC}	5	supply voltage
Y	6	data output

7. Functional description

Table 4. Function table

H = HIGH voltage level; L = LOW voltage level; Z = high-impedance OFF-state.

Input		Output	
EN	X1	X2	Y
L	L	H	H
L	H	L	L
H	L	H	Z
H	H	L	Z

8. Limiting values

Table 5. Limiting values

In accordance with the Absolute Maximum Rating System (IEC 60134). Voltages are referenced to GND (ground = 0 V).

Symbol	Parameter	Conditions	Min	Max	Unit
V _{CC}	supply voltage		-0.5	+4.6	V
I _{IK}	input clamping current	V _I < 0 V	-50	-	mA
V _I	input voltage		-0.5	+4.6	V
I _{OK}	output clamping current	V _O < 0 V	-50	-	mA
V _O	output voltage	Active mode and Power-down mode	-0.5	+4.6	V
I _O	output current	V _O = 0 V to V _{CC}	-	±20	mA
I _{CC}	supply current		-	50	mA
I _{GND}	ground current		-50	-	mA
T _{stg}	storage temperature		-65	+150	°C
P _{tot}	total power dissipation	T _{amb} = -40 °C to +125 °C	-	250	mW

[1] The input and output voltage ratings may be exceeded if the input and output current ratings are observed.

[2] For SOT363 (SC-88) package: P_{tot} derates linearly with 3.7 mW/K above 83 °C.
 For SOT886 (XSON6) package: P_{tot} derates linearly with 3.3 mW/K above 74 °C.
 For SOT1115 (XSON6) package: P_{tot} derates linearly with 3.2 mW/K above 71 °C.
 For SOT1202 (XSON6) package: P_{tot} derates linearly with 3.3 mW/K above 74 °C.

9. Recommended operating conditions

Table 6. Recommended operating conditions

Symbol	Parameter	Conditions
V_{CC}	supply voltage	
V_I	input voltage	
V_O	output voltage	
T_{amb}	ambient temperature	
$\Delta t/\Delta V$	input transition rise and fall rate	$V_{CC} = 0.8\text{ V to }3.6\text{ V}$

10. Static characteristics

Table 7. Static characteristics

At recommended operating conditions; voltages are referenced to GND (ground = 0 V).

Symbol	Parameter	Conditions	$T_{amb} = 25\text{ }^\circ\text{C}$			$T_{amb} = -40\text{ }^\circ\text{C}$
			Min	Typ	Max	Min
V_{IH}	HIGH-level input voltage	X1 input; $V_{CC} = 0.8\text{ V to }3.6\text{ V}$	$0.75V_{CC}$	-	-	$0.75V_{CC}$
		EN input				
		$V_{CC} = 0.8\text{ V}$	$0.70V_{CC}$	-	-	$0.70V_{CC}$
		$V_{CC} = 0.9\text{ V to }1.95\text{ V}$	$0.65V_{CC}$	-	-	$0.65V_{CC}$
		$V_{CC} = 2.3\text{ V to }2.7\text{ V}$	1.6	-	-	1.6
	$V_{CC} = 3.0\text{ V to }3.6\text{ V}$	2.0	-	-	2.0	
V_{IL}	LOW-level input voltage	X1 input; $V_{CC} = 0.8\text{ V to }3.6\text{ V}$	-	-	$0.25V_{CC}$	-
		EN input				
		$V_{CC} = 0.8\text{ V}$	-	-	$0.30V_{CC}$	-
		$V_{CC} = 0.9\text{ V to }1.95\text{ V}$	-	-	$0.35V_{CC}$	-
		$V_{CC} = 2.3\text{ V to }2.7\text{ V}$	-	-	0.7	-
	$V_{CC} = 3.0\text{ V to }3.6\text{ V}$	-	-	0.9	-	

Symbol	Parameter	Conditions	T _{amb} = 25 °C			T _{amb} = -40 °C
			Min	Typ	Max	Min
V _{OH}	HIGH-level output voltage	Y output; V _I at X1 input = V _{IH} or V _{IL}				
		I _O = -20 μA; V _{CC} = 0.8 V to 3.6 V	V _{CC} - 0.1	-	-	V _{CC} - 0.1
		I _O = -1.1 mA; V _{CC} = 1.1 V	0.75V _{CC}	-	-	0.7V _{CC}
		I _O = -1.7 mA; V _{CC} = 1.4 V	1.11	-	-	1.03
		I _O = -1.9 mA; V _{CC} = 1.65 V	1.32	-	-	1.30
		I _O = -2.3 mA; V _{CC} = 2.3 V	2.05	-	-	1.97
		I _O = -3.1 mA; V _{CC} = 2.3 V	1.9	-	-	1.85
		I _O = -2.7 mA; V _{CC} = 3.0 V	2.72	-	-	2.67
		I _O = -4.0 mA; V _{CC} = 3.0 V	2.6	-	-	2.55
		X2 output; V _I = GND or V _{CC}				
		I _O = -20 μA; V _{CC} = 0.8 V to 3.6 V	V _{CC} - 0.1	-	-	V _{CC} - 0.1
		I _O = -1.1 mA; V _{CC} = 1.1 V	0.75V _{CC}	-	-	0.7V _{CC}
		I _O = -1.7 mA; V _{CC} = 1.4 V	1.11	-	-	1.03
		I _O = -1.9 mA; V _{CC} = 1.65 V	1.32	-	-	1.30
		I _O = -2.3 mA; V _{CC} = 2.3 V	2.05	-	-	1.97
		I _O = -3.1 mA; V _{CC} = 2.3 V	1.9	-	-	1.85
		I _O = -2.7 mA; V _{CC} = 3.0 V	2.72	-	-	2.67
		I _O = -4.0 mA; V _{CC} = 3.0 V	2.6	-	-	2.55

Symbol	Parameter	Conditions	T _{amb} = 25 °C			T _{amb} = -40 °C
			Min	Typ	Max	Min
V _{OL}	LOW-level output voltage	Y output; V _I at X1 input = V _{IH} or V _{IL}				
		I _O = 20 μA; V _{CC} = 0.8 V to 3.6 V	-	-	0.1	-
		I _O = 1.1 mA; V _{CC} = 1.1 V	-	-	0.3V _{CC}	-
		I _O = 1.7 mA; V _{CC} = 1.4 V	-	-	0.31	-
		I _O = 1.9 mA; V _{CC} = 1.65 V	-	-	0.31	-
		I _O = 2.3 mA; V _{CC} = 2.3 V	-	-	0.31	-
		I _O = 3.1 mA; V _{CC} = 2.3 V	-	-	0.44	-
		I _O = 2.7 mA; V _{CC} = 3.0 V	-	-	0.31	-
		I _O = 4.0 mA; V _{CC} = 3.0 V	-	-	0.44	-
		X2 output; V _I = GND or V _{CC}				
		I _O = 20 μA; V _{CC} = 0.8 V to 3.6 V	-	-	0.1	-
		I _O = 1.1 mA; V _{CC} = 1.1 V	-	-	0.3V _{CC}	-
		I _O = 1.7 mA; V _{CC} = 1.4 V	-	-	0.31	-
		I _O = 1.9 mA; V _{CC} = 1.65 V	-	-	0.31	-
		I _O = 2.3 mA; V _{CC} = 2.3 V	-	-	0.31	-
		I _O = 3.1 mA; V _{CC} = 2.3 V	-	-	0.44	-
		I _O = 2.7 mA; V _{CC} = 3.0 V	-	-	0.31	-
		I _O = 4.0 mA; V _{CC} = 3.0 V	-	-	0.44	-
I _I	input leakage current	X1 input; V _I = $\overline{\text{EN}}$ = V _{CC} ; V _{CC} = 0 V to 3.6 V	-	-	±0.1	-
		$\overline{\text{EN}}$ input; V _I = GND to 3.6 V; V _{CC} = 0 V to 3.6 V	-	-	±0.1	-
I _{pu}	pull-up current	X1 input; $\overline{\text{EN}}$ = V _{CC} ; V _I = GND; V _{CC} = 0.8 V to 3.6 V	-	-	15	-
I _{OZ}	OFF-state output current	Y output; V _O = 0 V to 3.6 V; V _{CC} = 0 V to 3.6 V; $\overline{\text{EN}}$ = V _{CC}	-	-	±0.1	-
I _{OFF}	power-off leakage current	Only for output Y and input $\overline{\text{EN}}$. V _I or V _O = 0 V to 3.6 V; V _{CC} = 0 V	-	-	±0.2	-
ΔI _{OFF}	additional power-off leakage current	Only for output Y and input $\overline{\text{EN}}$. V _I or V _O = 0 V to 3.6 V; V _{CC} = 0 V to 0.2 V	-	-	±0.2	-

Symbol	Parameter	Conditions	T _{amb} = 25 °C			T _{amb} = -40 °C
			Min	Typ	Max	Min
I _{CC}	supply current	V _I = GND or V _{CC} ; I _O = 0 A; V _{CC} = 0.8 V to 3.6 V	-	-	75	-
ΔI _{CC}	additional supply current	$\overline{\text{EN}}$ input; V _I = V _{CC} - 0.6 V; I _O = 0 A; V _{CC} = 3.3 V	-	-	40	-
C _I	input capacitance	X1 input; V _{CC} = 0 V to 3.6 V; V _I = GND or V _{CC}	-	1.3	-	-
		$\overline{\text{EN}}$ input; V _{CC} = 0 V to 3.6 V; V _I = GND or V _{CC}	-	0.8	-	-
C _O	output capacitance	X2 output; V _O = GND; V _{CC} = 0 V	-	1.5	-	-
		Y output; V _O = GND; V _{CC} = 0 V	-	1.7	-	-
g _{fs}	forward transconductance	see Fig. 5 and Fig. 6				
		V _{CC} = 0.8 V	-	-	-	-
		V _{CC} = 1.1 V to 1.3 V	0.2	-	9.9	-
		V _{CC} = 1.4 V to 1.6 V	3.9	-	17.7	1.8
		V _{CC} = 1.65 V to 1.95 V	7.9	-	24.3	7.5
		V _{CC} = 2.3 V to 2.7 V	18	-	30.7	15.0
	V _{CC} = 3.0 V to 3.6 V	20.5	-	32.4	17.8	
R _{bias}	bias resistance	$\overline{\text{EN}}$ = GND; f _i = 0 Hz; V _I = 0 V or V _{CC} ; see Fig. 7 ; for frequency behavior see Fig. 8	1.08	1.62	3.08	1.07

11. Test circuits and graphs

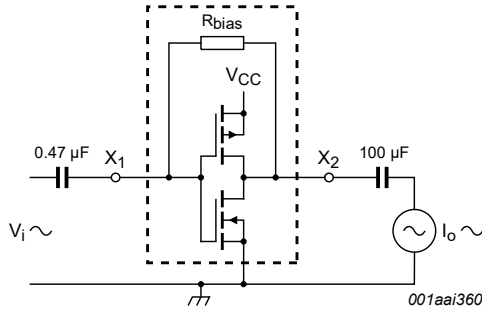

$$g_{fs} = \frac{\Delta I_O}{\Delta V_I}$$

$f_i = 1$ kHz.
 V_O is constant.

Fig. 5. Test set-up for measuring forward transconductance

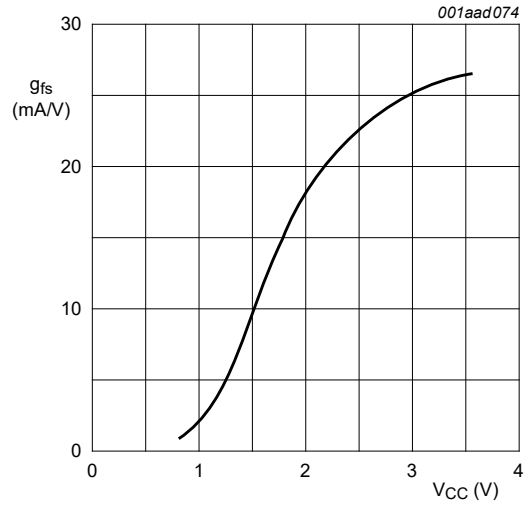

$T_{amb} = 25$ °C.

Fig. 6. Typical forward transconductance as a function of supply voltage

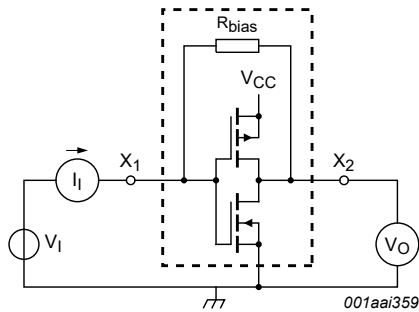

$$R_{bias} = \left| \frac{V_O - V_I}{I_I} \right|$$

Fig. 7. Test circuit for measuring bias resistance

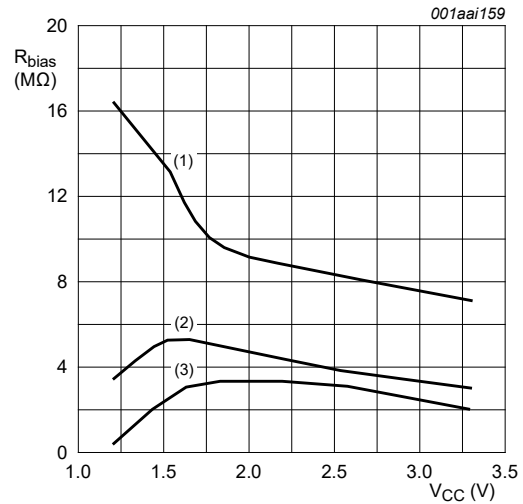

(1) $f_i = 30$ kHz.
 (2) $f_i = 1$ MHz
 (3) $f_i = 10$ MHz

Fig. 8. Typical bias resistance versus supply voltage

12. Dynamic characteristics

Table 8. Dynamic characteristics

Voltages are referenced to GND (ground = 0 V); for test circuit see Fig. 11.

Symbol	Parameter	Conditions	25 °C			-40 °C to +85 °C		-40 °C to +125 °C		Unit
			Min	Typ[1]	Max	Min	Max	Min	Max	
C_L = 5 pF										
t _{pd}	propagation delay	X1 to X2; see Fig. 9 [2]								
		V _{CC} = 0.8 V	-	6.2	-	-	-	-	-	ns
		V _{CC} = 1.1 V to 1.3 V	0.9	2.3	4.4	0.9	4.8	0.9	5.3	ns
		V _{CC} = 1.4 V to 1.6 V	0.7	1.7	3.1	0.6	3.4	0.6	3.8	ns
		V _{CC} = 1.65 V to 1.95 V	0.5	1.4	2.6	0.5	2.9	0.5	3.2	ns
		V _{CC} = 2.3 V to 2.7 V	0.4	1.1	2.0	0.4	2.3	0.4	2.6	ns
		V _{CC} = 3.0 V to 3.6 V	0.3	1.0	1.8	0.3	2.1	0.3	2.4	ns
		X1 to Y; see Fig. 9 [2]								
		V _{CC} = 0.8 V	-	18.5	-	-	-	-	-	ns
		V _{CC} = 1.1 V to 1.3 V	2.8	5.9	12.5	3.2	14.8	3.2	16.3	ns
		V _{CC} = 1.4 V to 1.6 V	2.2	4.2	7.7	2.6	9.1	2.6	10.1	ns
		V _{CC} = 1.65 V to 1.95 V	1.9	3.5	6.2	2.2	7.8	2.2	8.6	ns
		V _{CC} = 2.3 V to 2.7 V	1.6	2.9	4.8	1.9	6.2	1.9	6.9	ns
		V _{CC} = 3.0 V to 3.6 V	1.4	2.6	4.1	1.7	4.7	1.7	5.2	ns
t _{en}	enable time	EN to Y; see Fig. 10 [3]								
		V _{CC} = 0.8 V	-	31.2	-	-	-	-	-	ns
		V _{CC} = 1.1 V to 1.3 V	3.1	6.1	13.8	2.9	16.3	2.9	18.0	ns
		V _{CC} = 1.4 V to 1.6 V	2.5	4.3	8.2	2.3	9.7	2.3	10.7	ns
		V _{CC} = 1.65 V to 1.95 V	2.1	3.6	6.5	2.0	7.6	2.0	8.4	ns
		V _{CC} = 2.3 V to 2.7 V	1.8	2.9	4.8	1.7	5.8	1.7	6.4	ns
		V _{CC} = 3.0 V to 3.6 V	1.7	2.6	4.1	1.7	4.7	1.7	5.2	ns
t _{dis}	disable time	EN to Y; see Fig. 10 [4]								
		V _{CC} = 0.8 V	-	11.1	-	-	-	-	-	ns
		V _{CC} = 1.1 V to 1.3 V	2.5	4.5	9.0	2.9	9.4	2.9	10.4	ns
		V _{CC} = 1.4 V to 1.6 V	2.0	3.3	6.4	2.3	6.7	2.3	7.4	ns
		V _{CC} = 1.65 V to 1.95 V	1.9	3.2	6.0	2.0	6.4	2.0	7.1	ns
		V _{CC} = 2.3 V to 2.7 V	1.4	2.3	4.4	1.7	4.7	1.7	5.2	ns
		V _{CC} = 3.0 V to 3.6 V	1.7	2.6	4.4	1.7	4.9	1.7	5.4	ns

Low-power X-tal driver with enable and internal resistor; 3-state

Symbol	Parameter	Conditions	25 °C			-40 °C to +85 °C		-40 °C to +125 °C		Unit
			Min	Typ[1]	Max	Min	Max	Min	Max	
C_L = 10 pF										
t _{pd}	propagation delay	X1 to X2; see Fig. 9 [2]								
		V _{CC} = 0.8 V	-	9.6	-	-	-	-	-	ns
		V _{CC} = 1.1 V to 1.3 V	1.2	3.1	6.1	1.2	6.8	1.2	7.5	ns
		V _{CC} = 1.4 V to 1.6 V	1.0	2.3	4.0	0.9	4.6	0.9	5.1	ns
		V _{CC} = 1.65 V to 1.95 V	0.8	1.9	3.3	0.7	3.8	0.7	4.2	ns
		V _{CC} = 2.3 V to 2.7 V	0.6	1.5	2.7	0.6	3.1	0.6	3.5	ns
		V _{CC} = 3.0 V to 3.6 V	0.5	1.3	2.4	0.5	2.7	0.5	3.0	ns
		X1 to Y; see Fig. 9 [2]								
		V _{CC} = 0.8 V	-	21.4	-	-	-	-	-	ns
		V _{CC} = 1.1 V to 1.3 V	3.2	6.7	14.3	3.6	16.2	3.6	17.9	ns
		V _{CC} = 1.4 V to 1.6 V	2.1	4.9	8.9	3.0	10.1	3.0	11.2	ns
		V _{CC} = 1.65 V to 1.95 V	1.9	4.1	6.9	2.6	8.0	2.6	8.8	ns
V _{CC} = 2.3 V to 2.7 V	2.1	3.4	5.4	2.3	6.6	2.3	7.3	ns		
V _{CC} = 3.0 V to 3.6 V	1.8	3.1	4.8	2.1	5.6	2.1	6.2	ns		
t _{en}	enable time	$\overline{\text{EN}}$ to Y; see Fig. 10 [3]								
		V _{CC} = 0.8 V	-	34.4	-	-	-	-	ns	
		V _{CC} = 1.1 V to 1.3 V	3.6	6.9	15.5	3.4	16.0	3.4	17.6	ns
		V _{CC} = 1.4 V to 1.6 V	2.3	5.0	9.3	2.2	9.6	2.2	10.6	ns
		V _{CC} = 1.65 V to 1.95 V	2.0	4.2	7.2	1.9	7.9	1.9	8.7	ns
		V _{CC} = 2.3 V to 2.7 V	1.8	3.4	5.5	1.7	6.4	1.7	7.1	ns
V _{CC} = 3.0 V to 3.6 V	1.7	3.2	4.9	1.7	5.5	1.7	6.1	ns		
t _{dis}	disable time	$\overline{\text{EN}}$ to Y; see Fig. 10 [4]								
		V _{CC} = 0.8 V	-	13.0	-	-	-	-	ns	
		V _{CC} = 1.1 V to 1.3 V	3.4	5.7	10.4	3.4	10.8	3.4	11.9	ns
		V _{CC} = 1.4 V to 1.6 V	2.1	4.2	7.6	2.2	8.0	2.2	8.8	ns
		V _{CC} = 1.65 V to 1.95 V	2.2	4.3	7.3	1.9	7.6	1.9	8.4	ns
		V _{CC} = 2.3 V to 2.7 V	1.6	3.1	5.3	1.7	5.5	1.7	6.1	ns
V _{CC} = 3.0 V to 3.6 V	2.1	3.8	6.0	1.7	6.5	1.7	7.2	ns		

Low-power X-tal driver with enable and internal resistor; 3-state

Symbol	Parameter	Conditions	25 °C			-40 °C to +85 °C		-40 °C to +125 °C		Unit
			Min	Typ[1]	Max	Min	Max	Min	Max	
C_L = 15 pF										
t _{pd}	propagation delay	X1 to X2; see Fig. 9 [2]								
		V _{CC} = 0.8 V	-	13.0	-	-	-	-	-	ns
		V _{CC} = 1.1 V to 1.3 V	1.6	3.8	7.9	1.4	8.8	1.4	9.7	ns
		V _{CC} = 1.4 V to 1.6 V	1.3	2.8	4.9	1.1	5.7	1.1	6.3	ns
		V _{CC} = 1.65 V to 1.95 V	1.0	2.3	4.0	0.9	4.7	0.9	5.2	ns
		V _{CC} = 2.3 V to 2.7 V	0.8	1.9	3.2	0.8	3.7	0.8	4.1	ns
		V _{CC} = 3.0 V to 3.6 V	0.7	1.6	2.9	0.7	3.3	0.7	3.7	ns
		X1 to Y; see Fig. 9 [2]								
		V _{CC} = 0.8 V	-	24.2	-	-	-	-	-	ns
		V _{CC} = 1.1 V to 1.3 V	3.6	7.5	16.1	4.0	17.6	4.0	19.4	ns
		V _{CC} = 1.4 V to 1.6 V	3.0	5.4	9.7	3.3	10.6	3.3	11.7	ns
		V _{CC} = 1.65 V to 1.95 V	2.2	4.6	7.7	2.9	9.0	2.9	9.9	ns
		V _{CC} = 2.3 V to 2.7 V	2.0	3.9	6.1	2.6	7.3	2.6	8.1	ns
		V _{CC} = 3.0 V to 3.6 V	2.0	3.6	5.4	2.3	5.9	2.3	6.5	ns
t _{en}	enable time	$\overline{\text{EN}}$ to Y; see Fig. 10 [3]								
		V _{CC} = 0.8 V	-	37.5	-	-	-	-	ns	
		V _{CC} = 1.1 V to 1.3 V	4.0	7.7	17.2	3.7	17.5	3.7	19.3	ns
		V _{CC} = 1.4 V to 1.6 V	3.0	5.5	10.0	2.5	10.2	2.5	11.3	ns
		V _{CC} = 1.65 V to 1.95 V	2.3	4.7	7.9	2.1	9.2	2.1	10.2	ns
		V _{CC} = 2.3 V to 2.7 V	2.0	3.9	6.2	2.0	7.4	2.0	8.2	ns
		V _{CC} = 3.0 V to 3.6 V	2.0	3.6	5.5	1.9	6.0	1.9	6.6	ns

Low-power X-tal driver with enable and internal resistor; 3-state

Symbol	Parameter	Conditions	25 °C			-40 °C to +85 °C		-40 °C to +125 °C		Unit
			Min	Typ[1]	Max	Min	Max	Min	Max	
t _{dis}	disable time	\overline{EN} to Y; see Fig. 10 [4]								
		V _{CC} = 0.8 V	-	14.8	-	-	-	-	-	ns
		V _{CC} = 1.1 V to 1.3 V	4.3	6.8	11.2	3.7	12.4	3.7	13.7	ns
		V _{CC} = 1.4 V to 1.6 V	3.0	5.1	8.1	2.5	8.9	2.5	9.8	ns
		V _{CC} = 1.65 V to 1.95 V	3.0	5.4	8.0	2.1	9.3	2.1	10.3	ns
		V _{CC} = 2.3 V to 2.7 V	2.1	3.9	6.1	2.0	7.3	2.0	8.1	ns
		V _{CC} = 3.0 V to 3.6 V	2.9	5.1	7.2	1.9	7.9	1.9	8.7	ns
C_L = 30 pF										
t _{pd}	propagation delay	X1 to X2; see Fig. 9 [2]								
		V _{CC} = 0.8 V	-	23.2	-	-	-	-	-	ns
		V _{CC} = 1.1 V to 1.3 V	2.4	6.0	13.1	2.2	14.8	2.2	16.3	ns
		V _{CC} = 1.4 V to 1.6 V	2.0	4.2	7.6	1.8	9.0	1.8	9.9	ns
		V _{CC} = 1.65 V to 1.95 V	1.7	3.6	6.1	1.5	7.2	1.5	8.0	ns
		V _{CC} = 2.3 V to 2.7 V	1.4	2.9	4.8	1.3	5.7	1.3	6.3	ns
		V _{CC} = 3.0 V to 3.6 V	1.2	2.5	4.3	1.1	5.1	1.1	5.7	ns
		X1 to Y; see Fig. 9 [2]								
		V _{CC} = 0.8 V	-	32.6	-	-	-	-	-	ns
		V _{CC} = 1.1 V to 1.3 V	4.8	9.6	21.0	5.0	21.7	5.0	23.9	ns
		V _{CC} = 1.4 V to 1.6 V	4.0	6.9	12.4	4.3	13.5	4.3	14.9	ns
		V _{CC} = 1.65 V to 1.95 V	2.9	5.9	9.8	3.8	10.7	3.8	11.8	ns
		V _{CC} = 2.3 V to 2.7 V	2.7	5.0	7.5	3.3	8.2	3.3	9.1	ns
		V _{CC} = 3.0 V to 3.6 V	2.7	4.7	6.8	3.1	7.7	3.1	8.5	ns
t _{en}	enable time	\overline{EN} to Y; see Fig. 10 [3]								
		V _{CC} = 0.8 V	-	47.1	-	-	-	-	-	ns
		V _{CC} = 1.1 V to 1.3 V	5.2	9.9	21.0	4.8	21.7	4.8	23.9	ns
		V _{CC} = 1.4 V to 1.6 V	4.0	7.1	12.4	3.1	13.5	3.1	14.9	ns
		V _{CC} = 1.65 V to 1.95 V	3.0	6.0	9.9	2.8	10.7	2.8	11.8	ns
		V _{CC} = 2.3 V to 2.7 V	2.7	5.0	7.7	2.6	8.1	2.6	9.0	ns
		V _{CC} = 3.0 V to 3.6 V	2.7	4.8	6.8	2.6	7.7	2.6	8.5	ns
t _{dis}	disable time	\overline{EN} to Y; see Fig. 10 [4]								
		V _{CC} = 0.8 V	-	20.3	-	-	-	-	-	ns
		V _{CC} = 1.1 V to 1.3 V	6.0	10.2	15.3	4.8	16.5	4.8	18.2	ns
		V _{CC} = 1.4 V to 1.6 V	4.4	7.8	11.2	3.1	12.3	3.1	13.6	ns
		V _{CC} = 1.65 V to 1.95 V	5.1	8.8	12.5	2.8	13.3	2.8	14.7	ns
		V _{CC} = 2.3 V to 2.7 V	3.6	6.3	8.6	2.6	9.5	2.6	10.5	ns
		V _{CC} = 3.0 V to 3.6 V	5.2	8.8	11.5	2.6	13.0	2.6	14.3	ns

Low-power X-tal driver with enable and internal resistor; 3-state

Symbol	Parameter	Conditions	25 °C			-40 °C to +85 °C		-40 °C to +125 °C		Unit
			Min	Typ[1]	Max	Min	Max	Min	Max	
C_L = 5 pF, 10 pF, 15 pF and 30 pF										
C _{PD}	power dissipation capacitance	f _i = 1 MHz; \overline{EN} = GND; V _I = GND to V _{CC} [5] [6]								
		V _{CC} = 0.8 V	-	7.1	-	-	-	-	-	pF
		V _{CC} = 1.1 V to 1.3 V	-	12.9	-	-	-	-	-	pF
		V _{CC} = 1.4 V to 1.6 V	-	19.2	-	-	-	-	-	pF
		V _{CC} = 1.65 V to 1.95 V	-	19.9	-	-	-	-	-	pF
		V _{CC} = 2.3 V to 2.7 V	-	21.6	-	-	-	-	-	pF
		V _{CC} = 3.0 V to 3.6 V	-	24.3	-	-	-	-	-	pF

- [1] All typical values are measured at nominal V_{CC}.
- [2] t_{pd} is the same as t_{PLH} and t_{PHL}.
- [3] t_{en} is the same as t_{PZH} and t_{PZL}.
- [4] t_{dis} is the same as t_{PHZ} and t_{PLZ}.
- [5] C_{PD} is used to determine the dynamic power dissipation (P_D in μW).
 $P_D = C_{PD} \times V_{CC}^2 \times f_i \times N + \Sigma(C_L \times V_{CC}^2 \times f_o)$ where:
 f_i = input frequency in MHz;
 f_o = output frequency in MHz;
 C_L = output load capacitance in pF;
 V_{CC} = supply voltage in V;
 N = number of inputs switching;
 Σ(C_L × V_{CC}² × f_o) = sum of the outputs.
- [6] Feedback current is included in C_{PD}.

12.1. Waveforms and test circuit

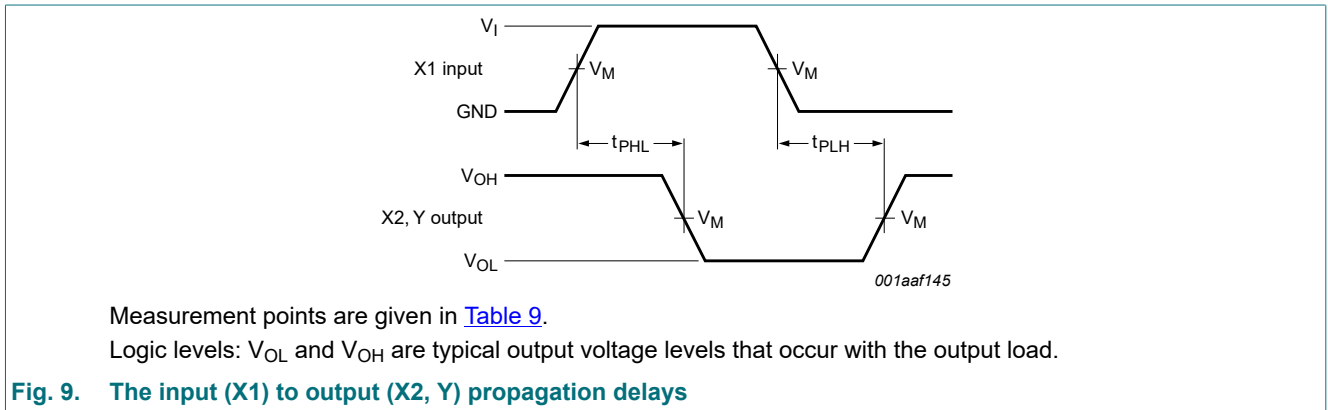
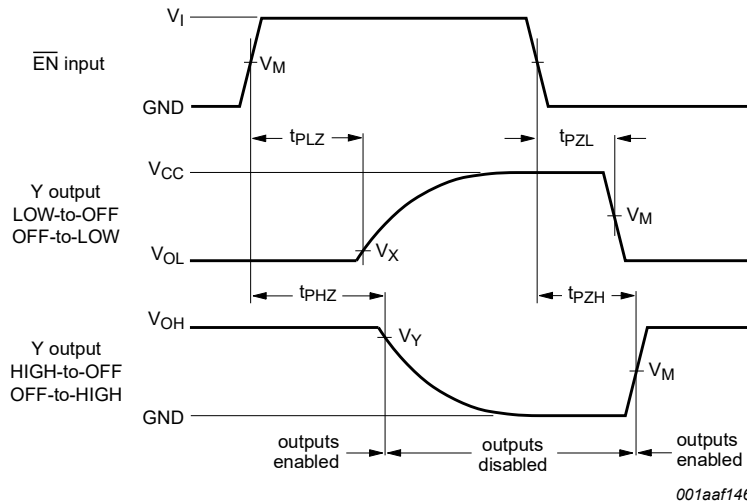

Table 9. Measurement points

Supply voltage	Output	Input		
V _{CC}	V _M	V _M	V _I	t _r = t _f
0.8 V to 3.6 V	0.5 × V _{CC}	0.5 × V _{CC}	V _{CC}	≤ 3.0 ns

Low-power X-tal driver with enable and internal resistor; 3-state



Measurement points are given in [Table 10](#).

Logic levels: V_{OL} and V_{OH} are typical output voltage levels that occur with the output load.

Fig. 10. Enable and disable times

Table 10. Measurement points

Supply voltage	Input	Output		
V_{CC}	V_M	V_M	V_X	V_Y
0.8 V to 1.6 V	$0.5 \times V_{CC}$	$0.5 \times V_{CC}$	$V_{OL} + 0.1 \text{ V}$	$V_{OH} - 0.1 \text{ V}$
1.65 V to 2.7 V	$0.5 \times V_{CC}$	$0.5 \times V_{CC}$	$V_{OL} + 0.15 \text{ V}$	$V_{OH} - 0.15 \text{ V}$
3.0 V to 3.6 V	$0.5 \times V_{CC}$	$0.5 \times V_{CC}$	$V_{OL} + 0.3 \text{ V}$	$V_{OH} - 0.3 \text{ V}$

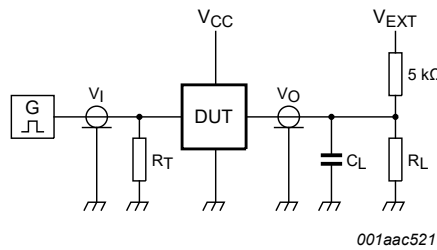

Test data is given in [Table 11](#).

Definitions for test circuit:

R_L = Load resistance.

C_L = Load capacitance including jig and probe capacitance.

R_T = Termination resistance should be equal to the output impedance Z_o of the pulse generator.

V_{EXT} = External voltage for measuring switching times.

Fig. 11. Test circuit for measuring switching times

Table 11. Test data

Supply voltage	Load		V_{EXT}		
V_{CC}	C_L	R_L [1]	t_{PLH} , t_{PHL}	t_{PZH} , t_{PHZ}	t_{PZL} , t_{PLZ}
0.8 V to 3.6 V	5 pF, 10 pF, 15 pF and 30 pF	5 kΩ or 1 MΩ	open	GND	$2 \times V_{CC}$

[1] For measuring enable and disable times $R_L = 5 \text{ k}\Omega$.

For measuring propagation delays, setup and hold times and pulse width $R_L = 1 \text{ M}\Omega$.

13. Application information

Crystal controlled oscillator circuits are widely used in clock pulse generators because of their excellent frequency stability and wide operating frequency range. The use of the 74AUP1Z125 provides the additional advantages of low power dissipation, stable operation over a wide range of frequency and temperature and a very small footprint. This application information describes crystal characteristics, design and testing of crystal oscillator circuits based on the 74AUP1Z125.

13.1. Crystal characteristics

Fig. 12 is the equivalent circuit of a quartz crystal.

The reactive and resistive components of the impedance of the crystal alone, and the crystal with a series and a parallel capacitance, is shown in Fig. 13.

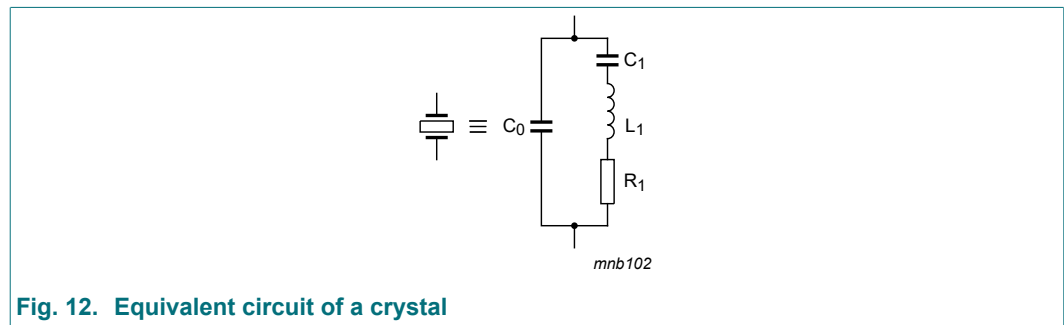

Fig. 12. Equivalent circuit of a crystal

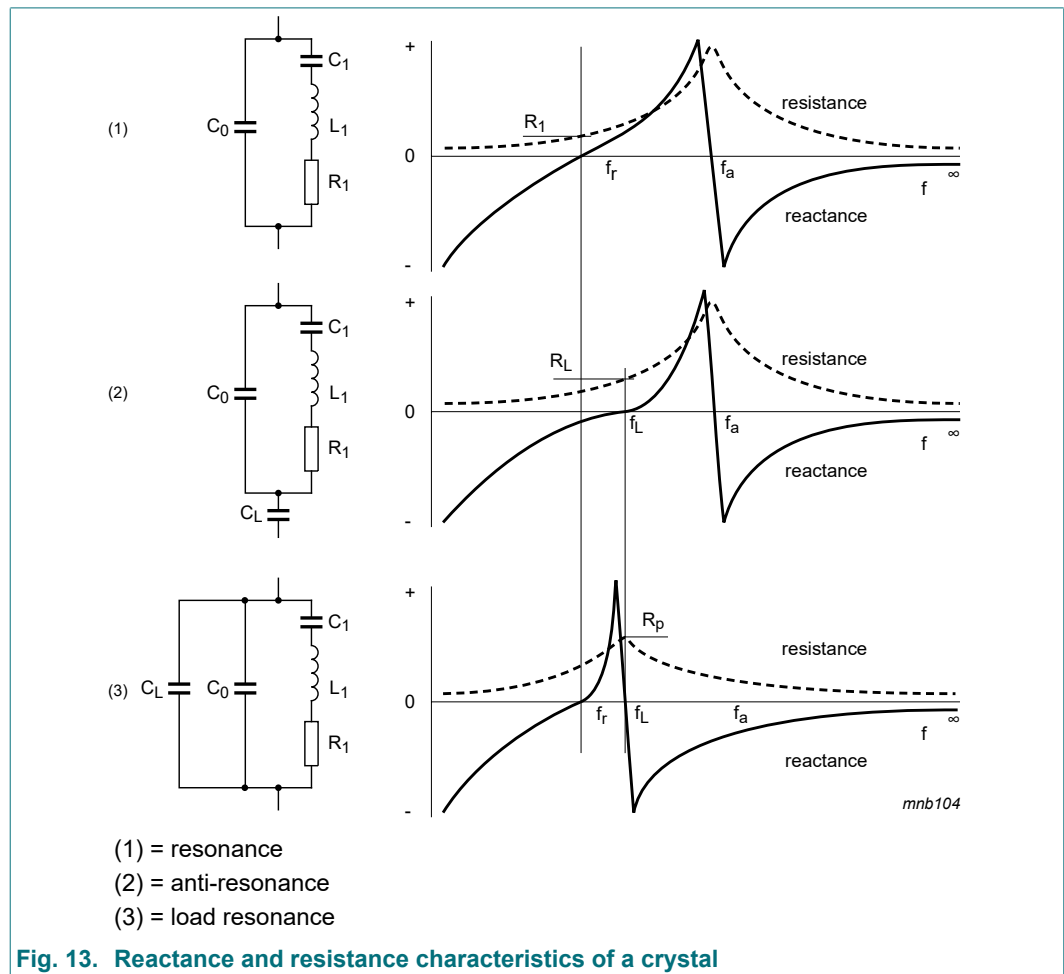

Fig. 13. Reactance and resistance characteristics of a crystal

13.1.1. Design

Fig. 14 shows the recommended way to connect a crystal to the 74AUP1Z125. This circuit is basically a Pierce oscillator circuit in which the crystal is operating at its fundamental frequency and tuned by the parallel load capacitance of C_1 and C_2 . C_1 and C_2 are in series with the crystal. They should be approximately equal. R_1 is the drive-limiting resistor and is set to approximately the same value as the reactance of C_1 at the crystal frequency ($R_1 = X_{C1}$). This results in an input to the crystal of 50 % of the rail-to-rail output of X2. This keeps the drive level into the crystal within drive specifications (the designer should verify this). Overdriving the crystal can cause damage.

The internal bias resistor provides negative feedback and sets a bias point of the inverter near mid-supply, operating the 74AUP1GU04 in the high gain linear region.

To calculate the values of C_1 and C_2 , the designer can use the formula:

$$C_L = \frac{C_1 \times C_2}{C_1 + C_2} + C_s$$

C_L is the load capacitance as specified by the crystal manufacturer. C_s is the stray capacitance of the circuit and for 74AUP1Z125, C_s is equal to an input capacitance of 1.5 pF.

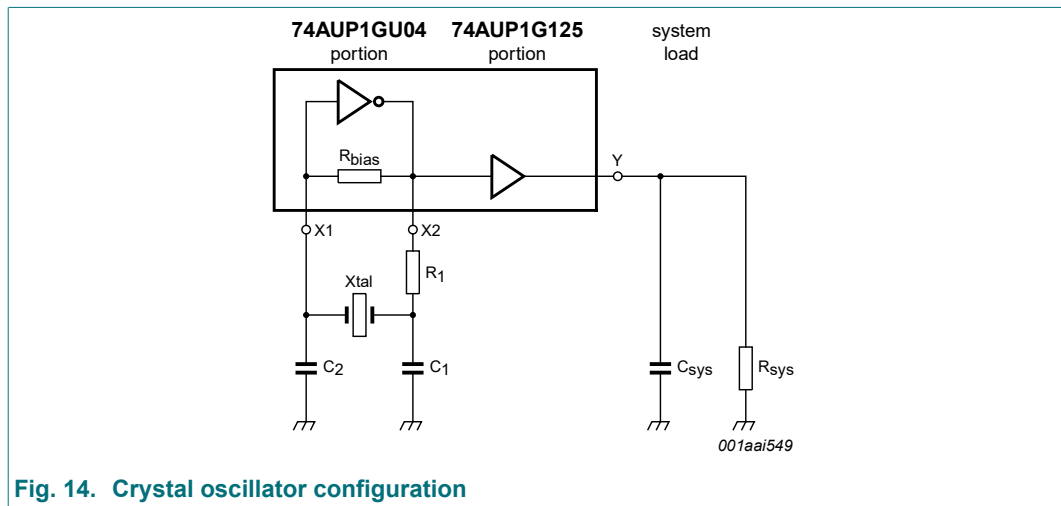

Fig. 14. Crystal oscillator configuration

13.1.2. Testing

After the calculations are performed for a particular crystal, the oscillator circuit should be tested. The following simple checks verify the prototype design of a crystal controlled oscillator circuit. Perform the checks after laying out the board:

- Test the oscillator over worst-case conditions (lowest supply voltage, worst-case crystal and highest operating temperature). Adding series and parallel resistors can simulate a worse case crystal.
- Insure that the circuit does not oscillate without the crystal.
- Check the frequency stability over a supply range greater than that which is likely to occur during normal operation.
- Check that the start-up time is within system requirements.

As the 74AUP1Z125 isolates the system loading, once the design is optimized, the single layout may work in multiple applications for any given crystal.

14. Package outline

Plastic surface-mounted package; 6 leads

SOT363

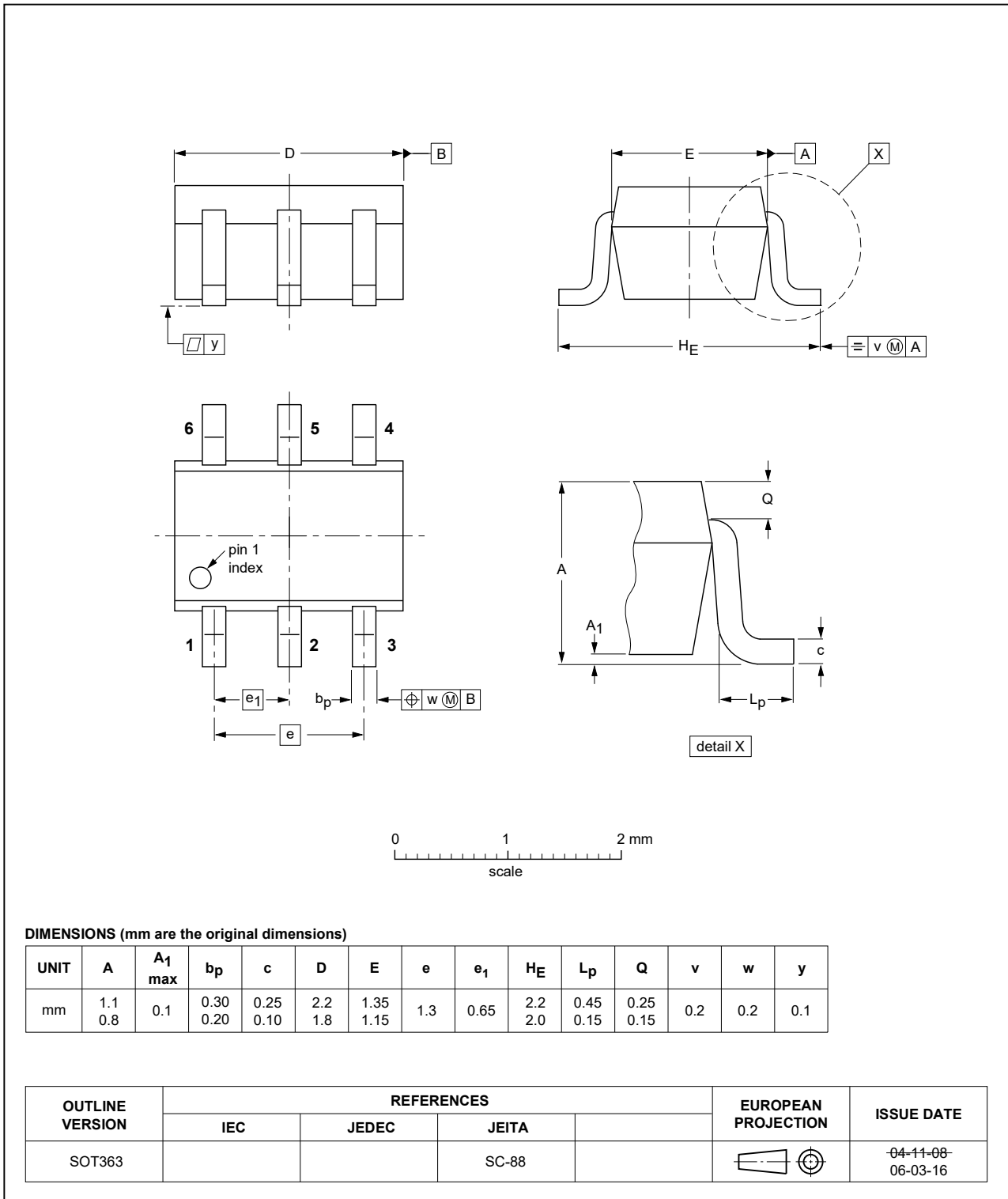

Fig. 15. Package outline SOT363 (SC-88)

XSON6: plastic extremely thin small outline package; no leads; 6 terminals; body 1 x 1.45 x 0.5 mm

SOT886

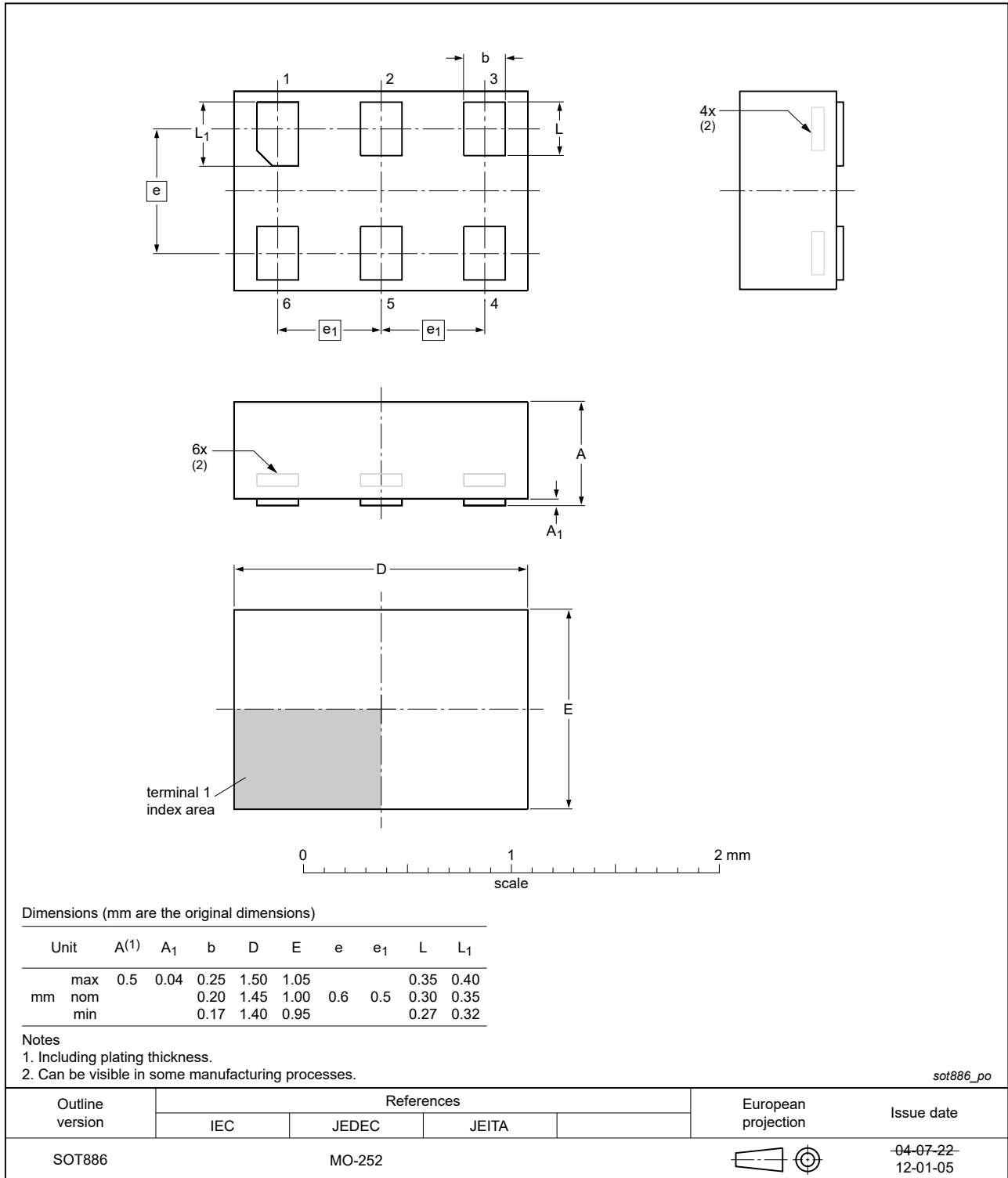

Fig. 16. Package outline SOT886 (XSON6)

XSON6: extremely thin small outline package; no leads;
6 terminals; body 0.9 x 1.0 x 0.35 mm

SOT1115

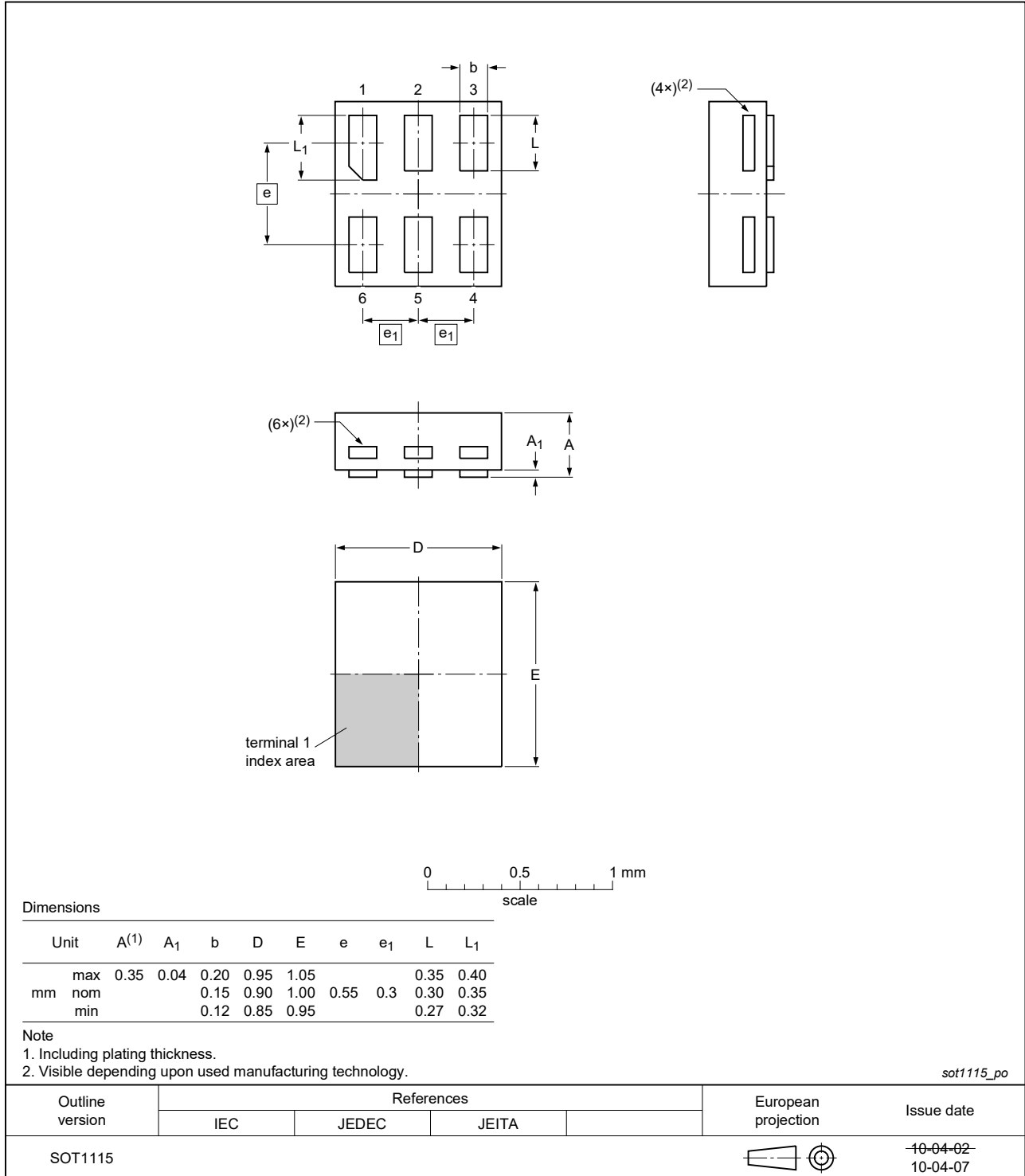

Fig. 17. Package outline SOT1115 (XSON6)

XSON6: extremely thin small outline package; no leads;
6 terminals; body 1.0 x 1.0 x 0.35 mm

SOT1202

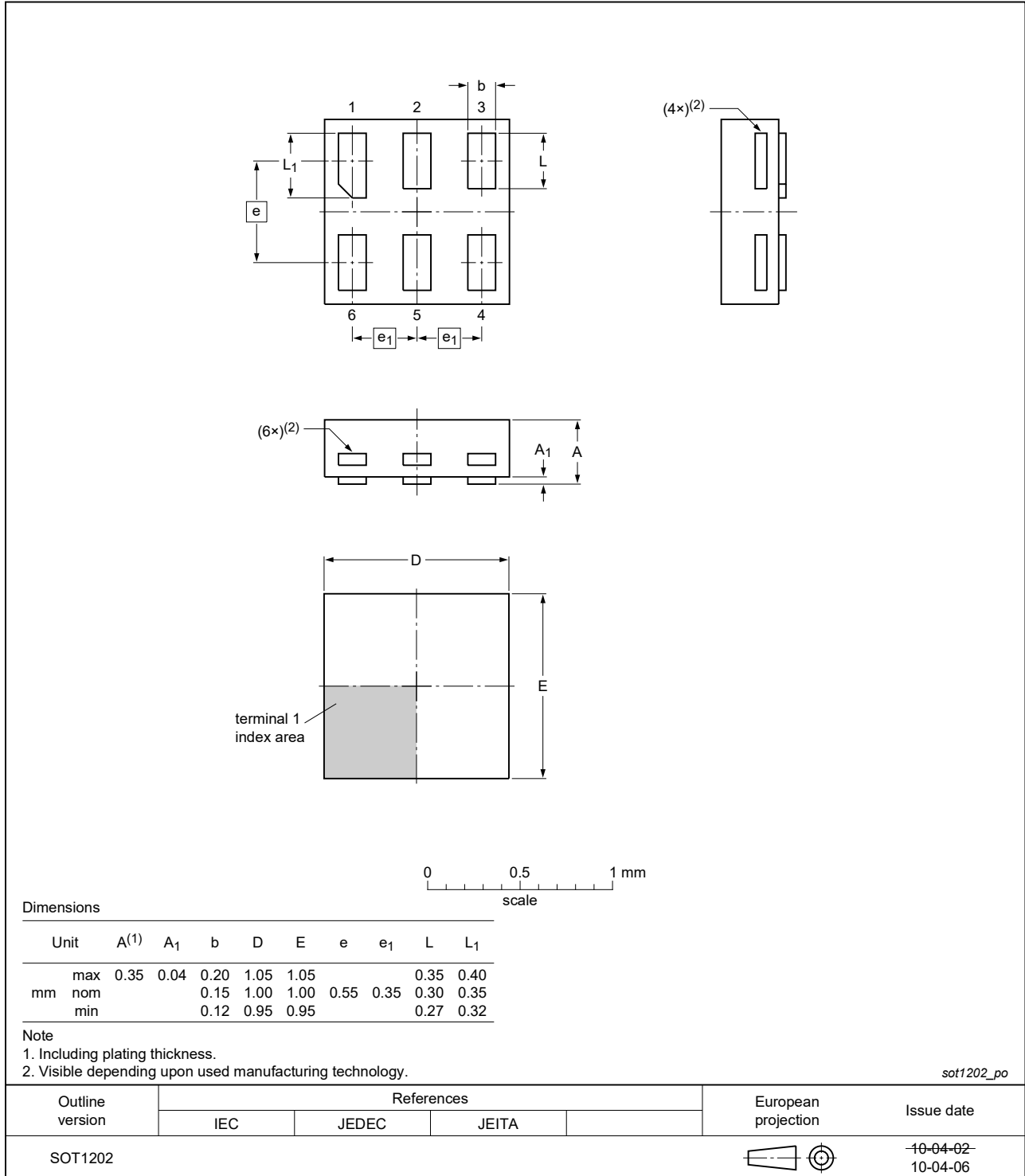

Fig. 18. Package outline SOT1202 (XSON6)

15. Abbreviations

Table 12. Abbreviations

Acronym	Description
CDM	Charged Device Model
DUT	Device Under Test
ESD	ElectroStatic Discharge
HBM	Human Body Model
MM	Machine Model

16. Revision history

Table 13. Revision history

Document ID	Release date	Data sheet status	Change notice	Supersedes
74AUP1Z125 v.6	20201211	Product data sheet	-	74AUP1Z125 v.5
Modifications:	<ul style="list-style-type: none"> The format of this data sheet has been redesigned to comply with the identity guidelines of Nexperia. Legal texts have been adapted to the new company name where appropriate. Type number 74AUP1Z125GF (SOT891 / XSON6) removed. Section 1 updated. Table 5: Derating values for P_{tot} total power dissipation updated. 			
74AUP1Z125 v.5	20120808	Product data sheet	-	74AUP1Z125 v.4
Modifications:	<ul style="list-style-type: none"> Package outline drawing of SOT886 (Fig. 16) modified. 			
74AUP1Z125 v.4	20111201	Product data sheet	-	74AUP1Z125 v.3
Modifications:	<ul style="list-style-type: none"> Legal pages updated. 			
74AUP1Z125 v.3	20100909	Product data sheet	-	74AUP1Z125 v.2
74AUP1Z125 v.2	20080807	Product data sheet	-	74AUP1Z125 v.1
74AUP1Z125 v.1	20060803	Product data sheet	-	-

17. Legal information

Data sheet status

Document status [1][2]	Product status [3]	Definition
Objective [short] data sheet	Development	This document contains data from the objective specification for product development.
Preliminary [short] data sheet	Qualification	This document contains data from the preliminary specification.
Product [short] data sheet	Production	This document contains the product specification.

- [1] Please consult the most recently issued document before initiating or completing a design.
- [2] The term 'short data sheet' is explained in section "Definitions".
- [3] The product status of device(s) described in this document may have changed since this document was published and may differ in case of multiple devices. The latest product status information is available on the internet at <https://www.nexperia.com>.

Definitions

Draft — The document is a draft version only. The content is still under internal review and subject to formal approval, which may result in modifications or additions. Nexperia does not give any representations or warranties as to the accuracy or completeness of information included herein and shall have no liability for the consequences of use of such information.

Short data sheet — A short data sheet is an extract from a full data sheet with the same product type number(s) and title. A short data sheet is intended for quick reference only and should not be relied upon to contain detailed and full information. For detailed and full information see the relevant full data sheet, which is available on request via the local Nexperia sales office. In case of any inconsistency or conflict with the short data sheet, the full data sheet shall prevail.

Product specification — The information and data provided in a Product data sheet shall define the specification of the product as agreed between Nexperia and its customer, unless Nexperia and customer have explicitly agreed otherwise in writing. In no event however, shall an agreement be valid in which the Nexperia product is deemed to offer functions and qualities beyond those described in the Product data sheet.

Disclaimers

Limited warranty and liability — Information in this document is believed to be accurate and reliable. However, Nexperia does not give any representations or warranties, expressed or implied, as to the accuracy or completeness of such information and shall have no liability for the consequences of use of such information. Nexperia takes no responsibility for the content in this document if provided by an information source outside of Nexperia.

In no event shall Nexperia be liable for any indirect, incidental, punitive, special or consequential damages (including - without limitation - lost profits, lost savings, business interruption, costs related to the removal or replacement of any products or rework charges) whether or not such damages are based on tort (including negligence), warranty, breach of contract or any other legal theory.

Notwithstanding any damages that customer might incur for any reason whatsoever, Nexperia's aggregate and cumulative liability towards customer for the products described herein shall be limited in accordance with the Terms and conditions of commercial sale of Nexperia.

Right to make changes — Nexperia reserves the right to make changes to information published in this document, including without limitation specifications and product descriptions, at any time and without notice. This document supersedes and replaces all information supplied prior to the publication hereof.

Suitability for use — Nexperia products are not designed, authorized or warranted to be suitable for use in life support, life-critical or safety-critical systems or equipment, nor in applications where failure or malfunction of an Nexperia product can reasonably be expected to result in personal

injury, death or severe property or environmental damage. Nexperia and its suppliers accept no liability for inclusion and/or use of Nexperia products in such equipment or applications and therefore such inclusion and/or use is at the customer's own risk.

Quick reference data — The Quick reference data is an extract of the product data given in the Limiting values and Characteristics sections of this document, and as such is not complete, exhaustive or legally binding.

Applications — Applications that are described herein for any of these products are for illustrative purposes only. Nexperia makes no representation or warranty that such applications will be suitable for the specified use without further testing or modification.

Customers are responsible for the design and operation of their applications and products using Nexperia products, and Nexperia accepts no liability for any assistance with applications or customer product design. It is customer's sole responsibility to determine whether the Nexperia product is suitable and fit for the customer's applications and products planned, as well as for the planned application and use of customer's third party customer(s). Customers should provide appropriate design and operating safeguards to minimize the risks associated with their applications and products.

Nexperia does not accept any liability related to any default, damage, costs or problem which is based on any weakness or default in the customer's applications or products, or the application or use by customer's third party customer(s). Customer is responsible for doing all necessary testing for the customer's applications and products using Nexperia products in order to avoid a default of the applications and the products or of the application or use by customer's third party customer(s). Nexperia does not accept any liability in this respect.

Limiting values — Stress above one or more limiting values (as defined in the Absolute Maximum Ratings System of IEC 60134) will cause permanent damage to the device. Limiting values are stress ratings only and (proper) operation of the device at these or any other conditions above those given in the Recommended operating conditions section (if present) or the Characteristics sections of this document is not warranted. Constant or repeated exposure to limiting values will permanently and irreversibly affect the quality and reliability of the device.

Terms and conditions of commercial sale — Nexperia products are sold subject to the general terms and conditions of commercial sale, as published at <http://www.nexperia.com/profile/terms>, unless otherwise agreed in a valid written individual agreement. In case an individual agreement is concluded only the terms and conditions of the respective agreement shall apply. Nexperia hereby expressly objects to applying the customer's general terms and conditions with regard to the purchase of Nexperia products by customer.

No offer to sell or license — Nothing in this document may be interpreted or construed as an offer to sell products that is open for acceptance or the grant, conveyance or implication of any license under any copyrights, patents or other industrial or intellectual property rights.

Export control — This document as well as the item(s) described herein may be subject to export control regulations. Export might require a prior authorization from competent authorities.

Non-automotive qualified products — Unless this data sheet expressly states that this specific Nexperia product is automotive qualified, the product is not suitable for automotive use. It is neither qualified nor tested in accordance with automotive testing or application requirements. Nexperia accepts no liability for inclusion and/or use of non-automotive qualified products in automotive equipment or applications.

In the event that customer uses the product for design-in and use in automotive applications to automotive specifications and standards, customer (a) shall use the product without Nexperia's warranty of the product for such automotive applications, use and specifications, and (b) whenever customer uses the product for automotive applications beyond Nexperia's specifications such use shall be solely at customer's own risk, and (c) customer fully indemnifies Nexperia for any liability, damages or failed product claims resulting from customer design and use of the product for automotive applications beyond Nexperia's standard warranty and Nexperia's product specifications.

Translations — A non-English (translated) version of a document is for reference only. The English version shall prevail in case of any discrepancy between the translated and English versions.

Trademarks

Notice: All referenced brands, product names, service names and trademarks are the property of their respective owners.

Contents

1. General description	1
2. Features and benefits	1
3. Ordering information	1
4. Marking	2
5. Functional diagram	2
6. Pinning information	2
6.1. Pinning.....	2
6.2. Pin description.....	3
7. Functional description	3
8. Limiting values	3
9. Recommended operating conditions	4
10. Static characteristics	4
11. Test circuits and graphs	8
12. Dynamic characteristics	9
12.1. Waveforms and test circuit.....	13
13. Application information	15
13.1. Crystal characteristics.....	15
13.1.1. Design.....	16
13.1.2. Testing.....	16
14. Package outline	17
15. Abbreviations	21
16. Revision history	21
17. Legal information	22

© Nexperia B.V. 2020. All rights reserved

For more information, please visit: <http://www.nexperia.com>

For sales office addresses, please send an email to: salesaddresses@nexperia.com

Date of release: 11 December 2020

X-ON Electronics

Largest Supplier of Electrical and Electronic Components

Click to view similar products for [Buffers & Line Drivers](#) category:

Click to view products by [Nexperia](#) manufacturer:

Other Similar products are found below :

[LXV200-024SW](#) [74AUP2G34FW3-7](#) [HEF4043BP](#) [NLU1GT126CMUTCG](#) [PI74FCT3244L](#) [MC74HCT365ADTR2G](#) [Le87401NQC](#)
[Le87402MQC](#) [028192B](#) [042140C](#) [051117G](#) [070519XB](#) [NL17SZ07P5T5G](#) [NLU1GT126AMUTCG](#) [74AUP1G17FW5-7](#) [74LVC2G17FW4-7](#)
[CD4502BE](#) [5962-8982101PA](#) [5962-9052201PA](#) [74LVC1G125FW4-7](#) [NL17SH17P5T5G](#) [74HCT126T14-13](#) [NL17SH125P5T5G](#)
[NLV37WZ07USG](#) [RHRXH162244K1](#) [74AUP1G34FW5-7](#) [74AUP1G07FW5-7](#) [74LVC2G126RA3-7](#) [NLX2G17CMUTCG](#)
[74LVCE1G125FZ4-7](#) [Le87501NQC](#) [74AUP1G126FW5-7](#) [TC74HC4050AP\(F\)](#) [74LVCE1G07FZ4-7](#) [NLX3G16DMUTCG](#)
[NLX2G06AMUTCG](#) [NLU2G17AMUTCG](#) [LE87100NQC](#) [LE87100NQCT](#) [LE87285NQC](#) [LE87285NQCT](#) [LE87290YQC](#) [LE87290YQCT](#)
[LE87511NQC](#) [LE87511NQCT](#) [LE87557NQC](#) [LE87557NQCT](#) [LE87614MQC](#) [LE87614MQCT](#) [LE87286NQCT](#)