

74HC4066-Q100; 74HCT4066-Q100

Quad single-pole single-throw analog switch

Rev. 4 — 14 April 2020

Product data sheet

1. General description

The 74HC4066-Q100; 74HCT4066-Q100 is a quad single pole, single throw analog switch. Each switch features two input/output terminals (nY and nZ) and an active HIGH enable input (nE). When nE is LOW, the analog switch is turned off. Inputs include clamp diodes. This enables the use of current limiting resistors to interface inputs to voltages in excess of V_{CC} .

This product has been qualified to the Automotive Electronics Council (AEC) standard Q100 (Grade 1) and is suitable for use in automotive applications.

2. Features and benefits

- Automotive product qualification in accordance with AEC-Q100 (Grade 1)
 - Specified from -40 °C to +85 °C and from -40 °C to +125 °C
- Input levels nE inputs:
 - For 74HC4066-Q100: CMOS level
 - For 74HCT4066-Q100: TTL level
- Low ON resistance:
 - 50 Ω (typical) at $V_{CC} = 4.5$ V
 - 45 Ω (typical) at $V_{CC} = 6.0$ V
 - 35 Ω (typical) at $V_{CC} = 9.0$ V
- Specified in compliance with JEDEC standard no. 7A
- ESD protection:
 - MIL-STD-883, method 3015 exceeds 2000 V
 - HBM JESD22-A114F exceeds 2000 V
 - MM JESD22-A115-A exceeds 200 V (C = 200 pF, R = 0 Ω)
- Multiple package options
- DHVQFN package with Side-Wettable Flanks enabling Automatic Optical Inspection (AOI) of solder joints

3. Ordering information

Table 1. Ordering information

Type number	Package			Version
	Temperature range	Name	Description	
74HC4066D-Q100	-40 °C to +125 °C	SO14	plastic small outline package; 14 leads; body width 3.9 mm	SOT108-1
74HCT4066D-Q100				
74HC4066PW-Q100	-40 °C to +125 °C	TSSOP14	plastic thin shrink small outline package; 14 leads; body width 4.4 mm	SOT402-1
74HCT4066PW-Q100				
74HC4066BQ-Q100	-40 °C to +125 °C	DHVQFN14	plastic dual in-line compatible thermal enhanced very thin quad flat package; no leads; 14 terminals; body 2.5 × 3 × 0.85 mm	SOT762-1
74HCT4066BQ-Q100				

4. Functional diagram

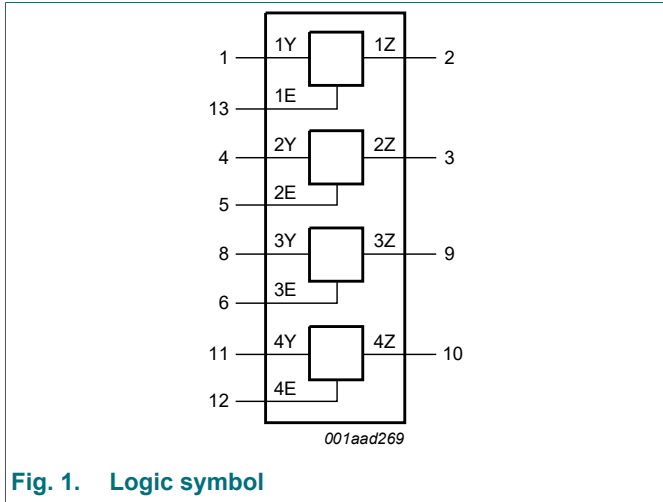

Fig. 1. Logic symbol

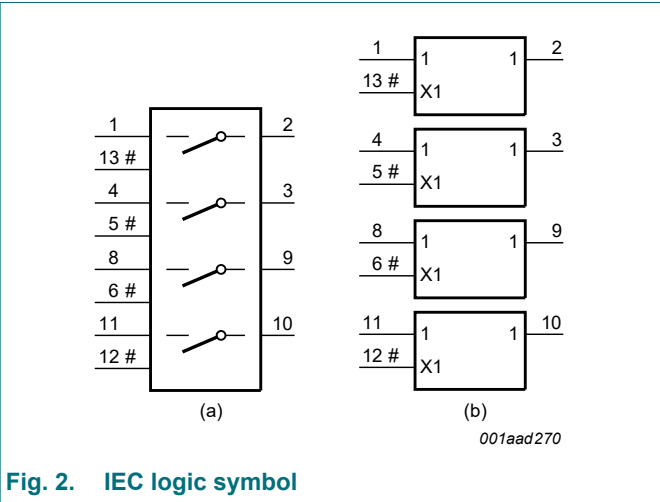

Fig. 2. IEC logic symbol

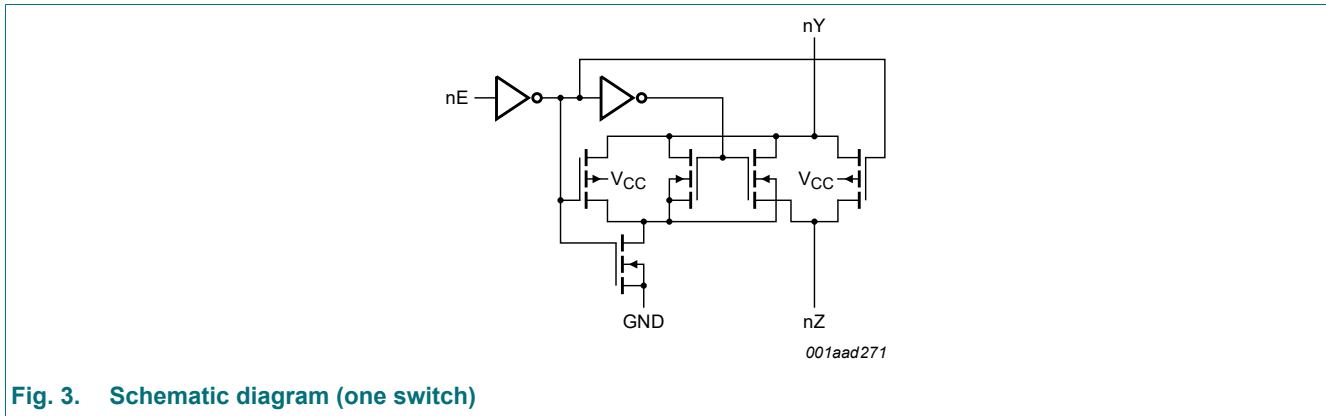

Fig. 3. Schematic diagram (one switch)

5. Pinning information

5.1. Pinning

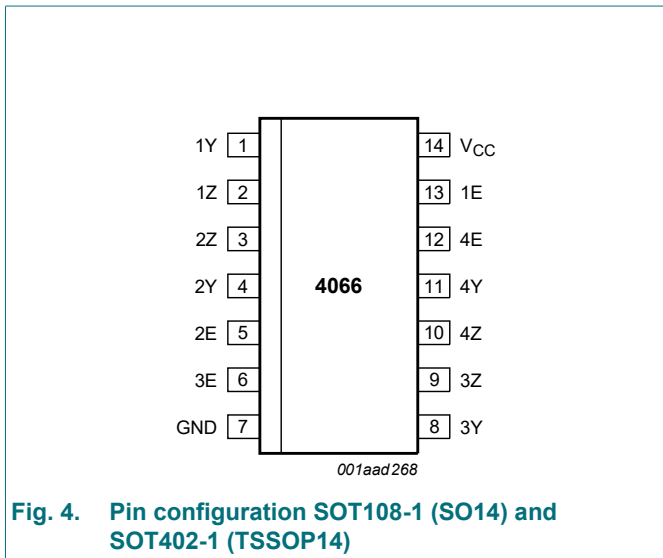

Fig. 4. Pin configuration SOT108-1 (SO14) and SOT402-1 (TSSOP14)

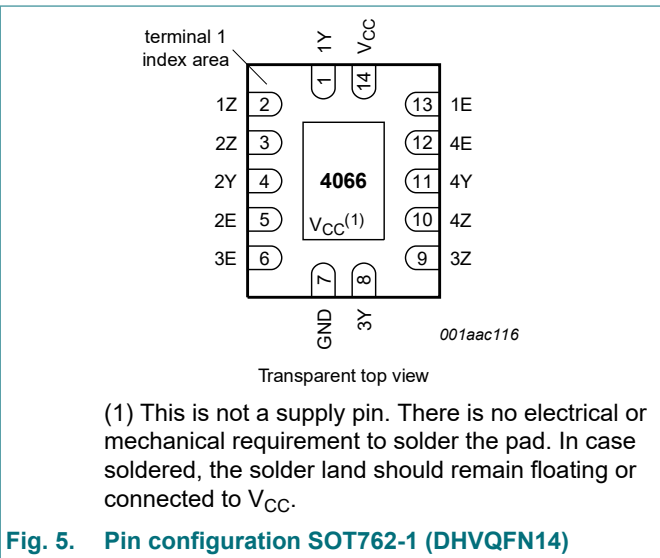

Fig. 5. Pin configuration SOT762-1 (DHVQFN14)

5.2. Pin description

Table 2. Pin description

Symbol	Pin	Description
1Z, 2Z, 3Z, 4Z	2, 3, 9, 10	independent input or output
1Y, 2Y, 3Y, 4Y	1, 4, 8, 11	independent input or output
GND	7	ground (0 V)
1E, 2E, 3E, 4E	13, 5, 6, 12	enable input (active HIGH)
V _{CC}	14	supply voltage

6. Functional description

Table 3. Function table

H = HIGH voltage level; L = LOW voltage level.

Input nE	Switch
L	OFF
H	ON

7. Limiting values

Table 4. Limiting values

In accordance with the Absolute Maximum Rating System (IEC 60134). Voltages are referenced to GND (ground = 0 V).

Symbol	Parameter	Conditions	Min	Max	Unit
V _{CC}	supply voltage		-0.5	+11.0	V
I _{IK}	input clamping current	V _I < -0.5 V or V _I > V _{CC} + 0.5 V	-	±20	mA
I _{SK}	switch clamping current	V _{SW} < -0.5 V or V _{SW} > V _{CC} + 0.5 V	-	±20	mA
I _{SW}	switch current	V _{SW} = -0.5 V to V _{CC} + 0.5 V [1]	-	±25	mA
I _{CC}	supply current		-	50	mA
I _{GND}	ground current		-	-50	mA
T _{stg}	storage temperature		-65	+150	°C
P _{tot}	total power dissipation	T _{amb} = -40 °C to +125 °C [2]	-	500	mW
P	power dissipation	per switch	-	100	mW

- [1] To avoid drawing V_{CC} current out of terminal Z, when switch current flows in terminals Y_n, the voltage drop across the bidirectional switch must not exceed 0.4 V. If the switch current flows into terminal Z, no V_{CC} current will flow out of terminals Y_n. In this case there is no limit for the voltage drop across the switch, but the voltages at Y_n and Z may not exceed V_{CC} or GND.
- [2] For SOT108-1 (SO14) package: P_{tot} derates linearly with 10.1 mW/K above 100 °C.
 For SOT402-1 (TSSOP14) package: P_{tot} derates linearly with 7.3 mW/K above 81 °C.
 For SOT762-1 (DHVQFN14) package: P_{tot} derates linearly with 9.6 mW/K above 98 °C.

8. Recommended operating conditions

Table 5. Recommended operating conditions

Symbol	Parameter	Conditions	74HC4066-Q100			74HCT4066-Q100			Unit
			Min	Typ	Max	Min	Typ	Max	
V _{CC}	supply voltage		2.0	5.0	10.0	4.5	5.0	5.5	V
V _I	input voltage		GND	-	V _{CC}	GND	-	V _{CC}	V
V _{SW}	switch voltage		GND	-	V _{CC}	GND	-	V _{CC}	V
T _{amb}	ambient temperature		-40	+25	+125	-40	+25	+125	°C
Δt/ΔV	input transition rise and fall rate	V _{CC} = 2.0 V	-	-	625	-	-	-	ns/V
		V _{CC} = 4.5 V	-	1.67	139	-	1.67	139	ns/V
		V _{CC} = 6.0 V	-	-	83	-	-	-	ns/V
		V _{CC} = 10.0 V	-	-	35	-	-	-	ns/V

9. Static characteristics

Table 6. R_{ON} resistance per switch for types 74HC4066-Q100 and 74HCT4066-Q100

V_I = V_{IH} or V_{IL}; for test circuit see Fig. 6.

V_{is} is the input voltage at a Yn or Z terminal, whichever is assigned as an input.

V_{os} is the output voltage at a Yn or Z terminal, whichever is assigned as an output.

For 74HC4066-Q100: V_{CC} - GND = 2.0 V, 4.5 V, 6.0 V and 9.0 V.

For 74HCT4066-Q100: V_{CC} - GND = 4.5 V.

Symbol	Parameter	Conditions	-40 °C to +85 °C			-40 °C to +125 °C		Unit
			Min	Typ[1]	Max	Min	Max	
R _{ON(peak)}	ON resistance (peak)	V _{is} = V _{CC} to GND						
		V _{CC} = 2.0 V; I _{SW} = 100 μA [2]	-	-	-	-	-	Ω
		V _{CC} = 4.5 V; I _{SW} = 1000 μA	-	54	-	118	142	Ω
		V _{CC} = 6.0 V; I _{SW} = 1000 μA	-	42	-	105	126	Ω
		V _{CC} = 9.0 V; I _{SW} = 1000 μA	-	32	-	88	105	Ω
R _{ON(rail)}	ON resistance (rail)	V _{is} = GND						
		V _{CC} = 2.0 V; I _{SW} = 100 μA [2]	-	80	-	-	-	Ω
		V _{CC} = 4.5 V; I _{SW} = 1000 μA	-	35	-	95	115	Ω
		V _{CC} = 6.0 V; I _{SW} = 1000 μA	-	27	-	82	100	Ω
		V _{CC} = 9.0 V; I _{SW} = 1000 μA	-	20	-	70	85	Ω
		V _{is} = V _{CC}						
		V _{CC} = 2.0 V; I _{SW} = 100 μA [2]	-	100	-	-	-	Ω
		V _{CC} = 4.5 V; I _{SW} = 1000 μA	-	42	-	106	128	Ω
		V _{CC} = 6.0 V; I _{SW} = 1000 μA	-	35	-	94	113	Ω
		V _{CC} = 9.0 V; I _{SW} = 1000 μA	-	20	-	78	95	Ω

Symbol	Parameter	Conditions	-40 °C to +85 °C			-40 °C to +125 °C		Unit
			Min	Typ[1]	Max	Min	Max	
ΔR_{ON}	ON resistance mismatch between channels	$V_{is} = V_{CC}$ to GND						
		$V_{CC} = 2.0$ V	[2]	-	-	-	-	Ω
		$V_{CC} = 4.5$ V		-	5	-	-	Ω
		$V_{CC} = 6.0$ V		-	4	-	-	Ω
		$V_{CC} = 9.0$ V		-	3	-	-	Ω

[1] Typical values are measured at $T_{amb} = 25$ °C.

[2] At supply voltages ($V_{CC} - GND$) approaching 2 V, the analog switch ON resistance becomes extremely non-linear. Therefore it is recommended that these devices be used to transmit digital signals only, when using these supply voltages.

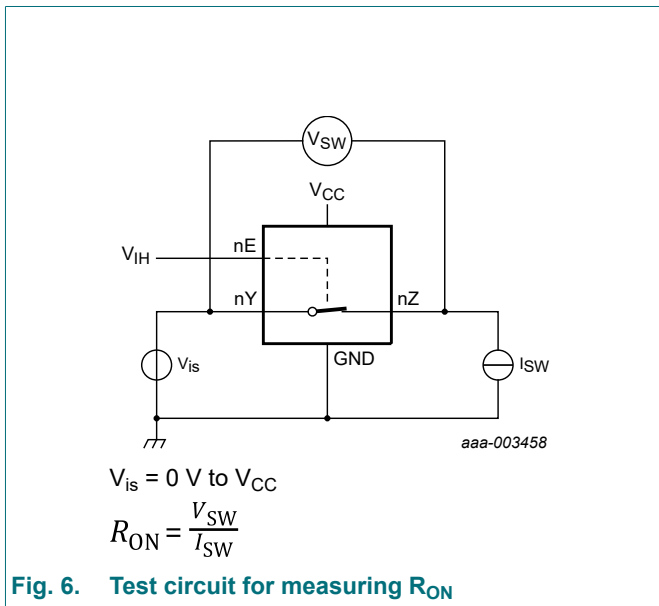

Fig. 6. Test circuit for measuring R_{ON}

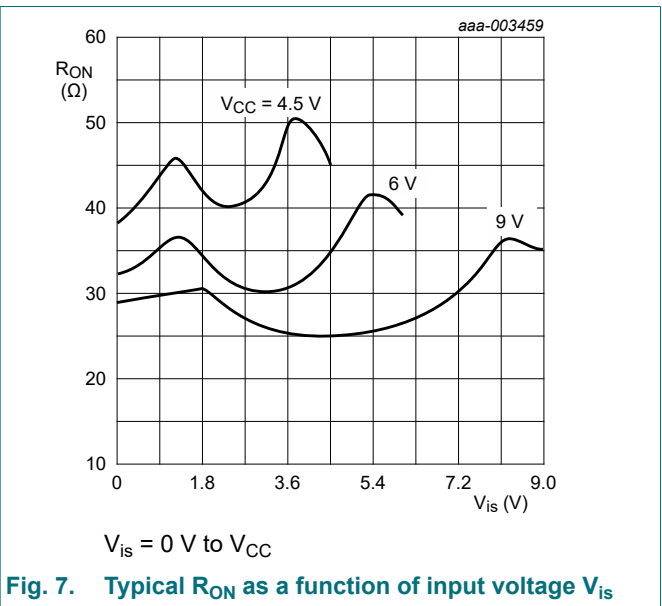

Fig. 7. Typical R_{ON} as a function of input voltage V_{is}

Table 7. Static characteristics 74HC4066-Q100

At recommended operating conditions; voltages are referenced to GND (ground = 0 V).

V_{is} is the input voltage at a Yn or Z terminal, whichever is assigned as an input.

V_{os} is the output voltage at a Yn or Z terminal, whichever is assigned as an output.

Symbol	Parameter	Conditions	Min	Typ[1]	Max	Unit
$T_{amb} = -40$ °C to $+85$ °C						
V_{IH}	HIGH-level input voltage	$V_{CC} = 2.0$ V	1.5	1.2	-	V
		$V_{CC} = 4.5$ V	3.15	2.4	-	V
		$V_{CC} = 6.0$ V	4.2	3.2	-	V
		$V_{CC} = 9.0$ V	6.3	4.7	-	V
V_{IL}	LOW-level input voltage	$V_{CC} = 2.0$ V	-	0.8	0.5	V
		$V_{CC} = 4.5$ V	-	2.1	1.35	V
		$V_{CC} = 6.0$ V	-	2.8	1.80	V
		$V_{CC} = 9.0$ V	-	4.3	2.70	V
I_I	input leakage current	$V_I = V_{CC}$ or GND				
		$V_{CC} = 6.0$ V	-	-	± 1.0	μA
		$V_{CC} = 10.0$ V	-	-	± 2.0	μA
$I_{S(OFF)}$	OFF-state leakage current	$V_{CC} = 10.0$ V; $V_I = V_{IH}$ or V_{IL} ; $ V_{SW} = V_{CC} - GND$; see Fig. 8				
		per channel	-	-	± 1.0	μA

Symbol	Parameter	Conditions	Min	Typ[1]	Max	Unit
$I_{S(ON)}$	ON-state leakage current	$V_{CC} = 10.0\text{ V}$; $V_I = V_{IH}$ or V_{IL} ; $ V_{SW} = V_{CC} - \text{GND}$; see Fig. 9	-	-	± 1.0	μA
I_{CC}	supply current	$V_I = V_{CC}$ or GND; $V_{is} = \text{GND}$ or V_{CC} ; $V_{os} = V_{CC}$ or GND				
		$V_{CC} = 6.0\text{ V}$	-	-	20.0	μA
		$V_{CC} = 10.0\text{ V}$	-	-	40.0	μA
C_I	input capacitance		-	3.5	-	pF
C_{SW}	switch capacitance		-	8	-	pF
$T_{amb} = -40\text{ }^\circ\text{C}$ to $+125\text{ }^\circ\text{C}$						
V_{IH}	HIGH-level input voltage	$V_{CC} = 2.0\text{ V}$	1.5	-	-	V
		$V_{CC} = 4.5\text{ V}$	3.15	-	-	V
		$V_{CC} = 6.0\text{ V}$	4.2	-	-	V
		$V_{CC} = 9.0\text{ V}$	6.3	-	-	V
V_{IL}	LOW-level input voltage	$V_{CC} = 2.0\text{ V}$	-	-	0.50	V
		$V_{CC} = 4.5\text{ V}$	-	-	1.35	V
		$V_{CC} = 6.0\text{ V}$	-	-	1.80	V
		$V_{CC} = 9.0\text{ V}$	-	-	2.70	V
I_I	input leakage current	$V_I = V_{CC}$ or GND				
		$V_{CC} = 6.0\text{ V}$	-	-	± 1.0	μA
		$V_{CC} = 10.0\text{ V}$	-	-	± 2.0	μA
$I_{S(OFF)}$	OFF-state leakage current	$V_{CC} = 10.0\text{ V}$; $V_I = V_{IH}$ or V_{IL} ; $ V_{SW} = V_{CC} - \text{GND}$; see Fig. 8				
		per channel	-	-	± 1.0	μA
$I_{S(ON)}$	ON-state leakage current	$V_{CC} = 10.0\text{ V}$; $V_I = V_{IH}$ or V_{IL} ; $ V_{SW} = V_{CC} - \text{GND}$; see Fig. 9	-	-	± 1.0	μA
I_{CC}	supply current	$V_I = V_{CC}$ or GND; $V_{is} = \text{GND}$ or V_{CC} ; $V_{os} = V_{CC}$ or GND				
		$V_{CC} = 6.0\text{ V}$	-	-	40	μA
		$V_{CC} = 10.0\text{ V}$	-	-	80	μA

[1] Typical values are measured at $T_{amb} = 25\text{ }^\circ\text{C}$.

Table 8. Static characteristics 74HCT4066-Q100

At recommended operating conditions; voltages are referenced to GND (ground = 0 V).

V_{is} is the input voltage at a Yn or Z terminal, whichever is assigned as an input.

V_{os} is the output voltage at a Yn or Z terminal, whichever is assigned as an output.

Symbol	Parameter	Conditions	Min	Typ[1]	Max	Unit
$T_{amb} = -40\text{ }^{\circ}\text{C to }+85\text{ }^{\circ}\text{C}$						
V_{IH}	HIGH-level input voltage	$V_{CC} = 4.5\text{ V to }5.5\text{ V}$	2.0	1.6	-	V
V_{IL}	LOW-level input voltage	$V_{CC} = 4.5\text{ V to }5.5\text{ V}$	-	1.2	0.8	V
I_I	input leakage current	$V_I = V_{CC}$ or GND; $V_{CC} = 5.5\text{ V}$	-	-	± 1.0	μA
$I_{S(OFF)}$	OFF-state leakage current	$V_{CC} = 5.5\text{ V}$; $V_I = V_{IH}$ or V_{IL} ; $ V_{SW} = V_{CC} - \text{GND}$; see Fig. 8				
		per channel	-	-	± 1.0	μA
$I_{S(ON)}$	ON-state leakage current	$V_{CC} = 5.5\text{ V}$; $V_I = V_{IH}$ or V_{IL} ; $ V_{SW} = V_{CC} - \text{GND}$; see Fig. 9	-	-	± 1.0	μA
I_{CC}	supply current	$V_I = V_{CC}$ or GND; $V_{is} = \text{GND}$ or V_{CC} ; $V_{os} = V_{CC}$ or GND; $V_{CC} = 4.5\text{ V to }5.5\text{ V}$	-	-	20.0	μA
ΔI_{CC}	additional supply current	per input pin; $V_I = V_{CC} - 2.1\text{ V}$; other inputs at V_{CC} or GND; $V_{CC} = 4.5\text{ V to }5.5\text{ V}$	-	100	450	μA
C_I	input capacitance		-	3.5	-	pF
C_{SW}	switch capacitance		-	8	-	pF
$T_{amb} = -40\text{ }^{\circ}\text{C to }+125\text{ }^{\circ}\text{C}$						
V_{IH}	HIGH-level input voltage	$V_{CC} = 4.5\text{ V to }5.5\text{ V}$	2.0	-	-	V
V_{IL}	LOW-level input voltage	$V_{CC} = 4.5\text{ V to }5.5\text{ V}$	-	-	0.8	V
I_I	input leakage current	$V_I = V_{CC}$ or GND; $V_{CC} = 5.5\text{ V}$	-	-	± 1.0	μA
$I_{S(OFF)}$	OFF-state leakage current	$V_{CC} = 5.5\text{ V}$; $V_I = V_{IH}$ or V_{IL} ; $ V_{SW} = V_{CC} - \text{GND}$; see Fig. 8				
		per channel	-	-	± 1.0	μA
$I_{S(ON)}$	ON-state leakage current	$V_{CC} = 5.5\text{ V}$; $V_I = V_{IH}$ or V_{IL} ; $ V_{SW} = V_{CC} - \text{GND}$; see Fig. 9	-	-	± 1.0	μA
I_{CC}	supply current	$V_I = V_{CC}$ or GND; $V_{is} = \text{GND}$ or V_{CC} ; $V_{os} = V_{CC}$ or GND; $V_{CC} = 4.5\text{ V to }5.5\text{ V}$	-	-	40	μA
ΔI_{CC}	additional supply current	per input pin; $V_I = V_{CC} - 2.1\text{ V}$; other inputs at V_{CC} or GND; $V_{CC} = 4.5\text{ V to }5.5\text{ V}$	-	-	490	μA

[1] Typical values are measured at $T_{amb} = 25\text{ }^{\circ}\text{C}$.

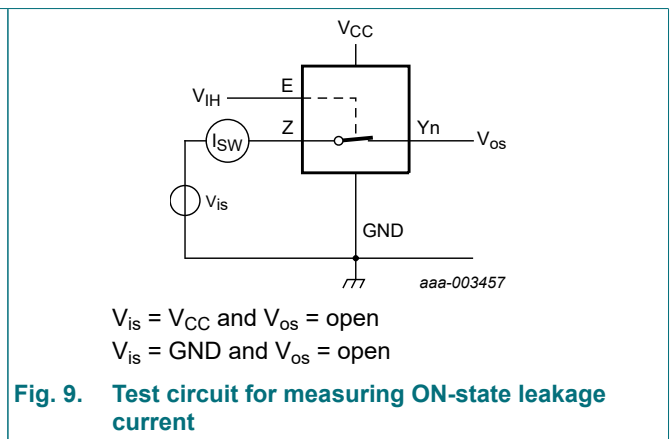
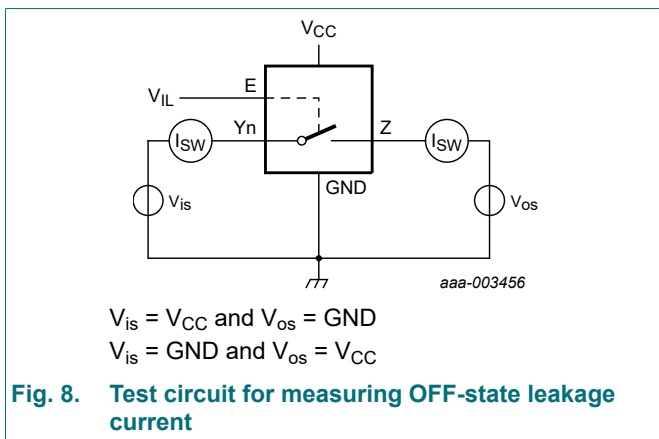

10. Dynamic characteristics

Table 9. Dynamic characteristics 74HC4066-Q100

$GND = 0\text{ V}$; $t_r = t_f = 6\text{ ns}$; $C_L = 50\text{ pF}$ unless specified otherwise; for test circuit see Fig. 12.

V_{is} is the input voltage at a Yn or Z terminal, whichever is assigned as an input.

V_{os} is the output voltage at a Yn or Z terminal, whichever is assigned as an output.

Symbol	Parameter	Conditions	-40 °C to +85 °C			-40 °C to +125 °C		Unit
			Min	Typ[1]	Max	Min	Max	
t_{pd}	propagation delay	nY to nZ or nZ to nY; $R_L = \infty\ \Omega$; see Fig. 10 [2]						
		$V_{CC} = 2.0\text{ V}$	-	8	75	-	90	ns
		$V_{CC} = 4.5\text{ V}$	-	3	15	-	18	ns
		$V_{CC} = 6.0\text{ V}$	-	2	13	-	15	ns
		$V_{CC} = 9.0\text{ V}$	-	2	10	-	12	ns
t_{off}	turn-off time	nE to nY or nZ; see Fig. 11 [3]						
		$V_{CC} = 2.0\text{ V}$	-	44	190	-	225	ns
		$V_{CC} = 4.5\text{ V}$	-	16	38	-	45	ns
		$V_{CC} = 5.0\text{ V}$; $C_L = 15\text{ pF}$	-	13	-	-	-	ns
		$V_{CC} = 6.0\text{ V}$	-	13	33	-	38	ns
		$V_{CC} = 9.0\text{ V}$	-	16	26	-	30	ns
t_{on}	turn-on time	nE to nY or nZ; see Fig. 11 [4]						
		$V_{CC} = 2.0\text{ V}$	-	36	125	-	150	ns
		$V_{CC} = 4.5\text{ V}$	-	13	25	-	30	ns
		$V_{CC} = 5.0\text{ V}$; $C_L = 15\text{ pF}$	-	11	-	-	-	ns
		$V_{CC} = 6.0\text{ V}$	-	10	21	-	26	ns
		$V_{CC} = 9.0\text{ V}$	-	8	16	-	20	ns
C_{PD}	power dissipation capacitance	per switch; $V_I = GND$ to V_{CC} [5]	-	11	-	-	-	pF

[1] Typical values are measured at $T_{amb} = 25\text{ °C}$.

[2] t_{pd} is the same as t_{PHL} and t_{PLH} .

[3] t_{off} is the same as t_{PZH} and t_{PZL} .

[4] t_{on} is the same as t_{PHZ} and t_{PLZ} .

[5] C_{PD} is used to determine the dynamic power dissipation (P_D in μW).

$$P_D = C_{PD} \times V_{CC}^2 \times f_i + \sum\{(C_L + C_{sw}) \times V_{CC}^2 \times f_o\} \text{ where:}$$

f_i = input frequency in MHz;

f_o = output frequency in MHz;

$\sum\{(C_L + C_{sw}) \times V_{CC}^2 \times f_o\}$ = sum of outputs;

C_L = output load capacitance in pF;

C_{sw} = switch capacitance in pF;

V_{CC} = supply voltage in V.

Table 10. Dynamic characteristics 74HCT4066-Q100

$GND = 0\text{ V}$; $t_r = t_f = 6\text{ ns}$; $C_L = 50\text{ pF}$ unless specified otherwise; for test circuit see Fig. 12.

V_{is} is the input voltage at a Yn or Z terminal, whichever is assigned as an input.

V_{os} is the output voltage at a Yn or Z terminal, whichever is assigned as an output.

Symbol	Parameter	Conditions	-40 °C to +85 °C			-40 °C to +125 °C		Unit
			Min	Typ[1]	Max	Min	Max	
t_{pd}	propagation delay	nY to nZ or nZ to nY; $R_L = \infty\ \Omega$; see Fig. 10 [2]						
		$V_{CC} = 4.5\text{ V}$	-	3	15	-	18	ns
t_{off}	turn-off time	nE to nY or nZ; see Fig. 11 [3]						
		$V_{CC} = 4.5\text{ V}$	-	20	44	-	53	ns
		$V_{CC} = 5.0\text{ V}$; $C_L = 15\text{ pF}$	-	16	-	-	-	ns
t_{on}	turn-on time	nE to nY or nZ; see Fig. 11 [4]						
		$V_{CC} = 4.5\text{ V}$	-	12	30	-	36	ns
		$V_{CC} = 5.0\text{ V}$; $C_L = 15\text{ pF}$	-	12	-	-	-	ns
C_{PD}	power dissipation capacitance	per switch; $V_I = GND$ to $(V_{CC} - 1.5\text{ V})$ [5]	-	12	-	-	-	pF

- [1] Typical values are measured at $T_{amb} = 25\text{ °C}$.
- [2] t_{pd} is the same as t_{PHL} and t_{PLH} .
- [3] t_{off} is the same as t_{PZH} and t_{PZL} .
- [4] t_{on} is the same as t_{PHZ} and t_{PLZ} .
- [5] C_{PD} is used to determine the dynamic power dissipation (P_D in μW).
 $P_D = C_{PD} \times V_{CC}^2 \times f_i + \sum\{(C_L + C_{sw}) \times V_{CC}^2 \times f_o\}$ where:
 f_i = input frequency in MHz;
 f_o = output frequency in MHz;
 $\sum\{(C_L + C_{sw}) \times V_{CC}^2 \times f_o\}$ = sum of outputs;
 C_L = output load capacitance in pF;
 C_{sw} = switch capacitance in pF;
 V_{CC} = supply voltage in V.

10.1. Waveforms and test circuit

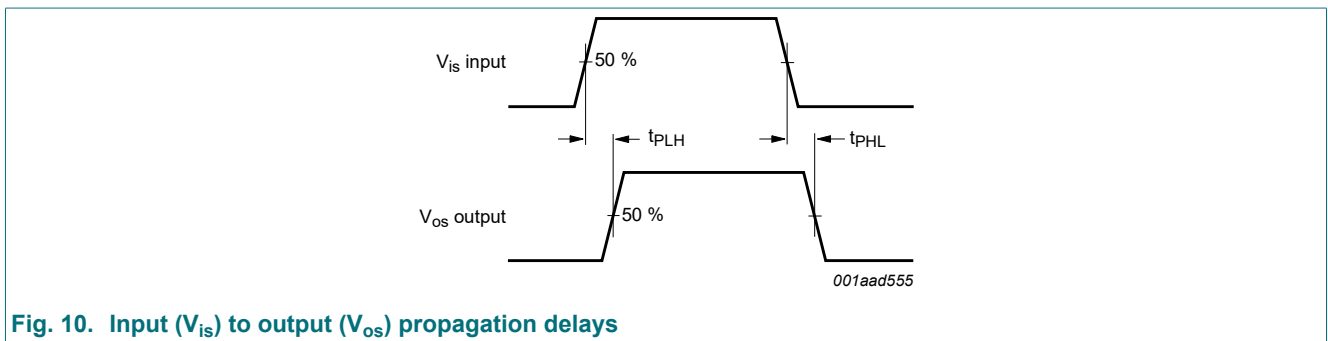

Fig. 10. Input (V_{is}) to output (V_{os}) propagation delays

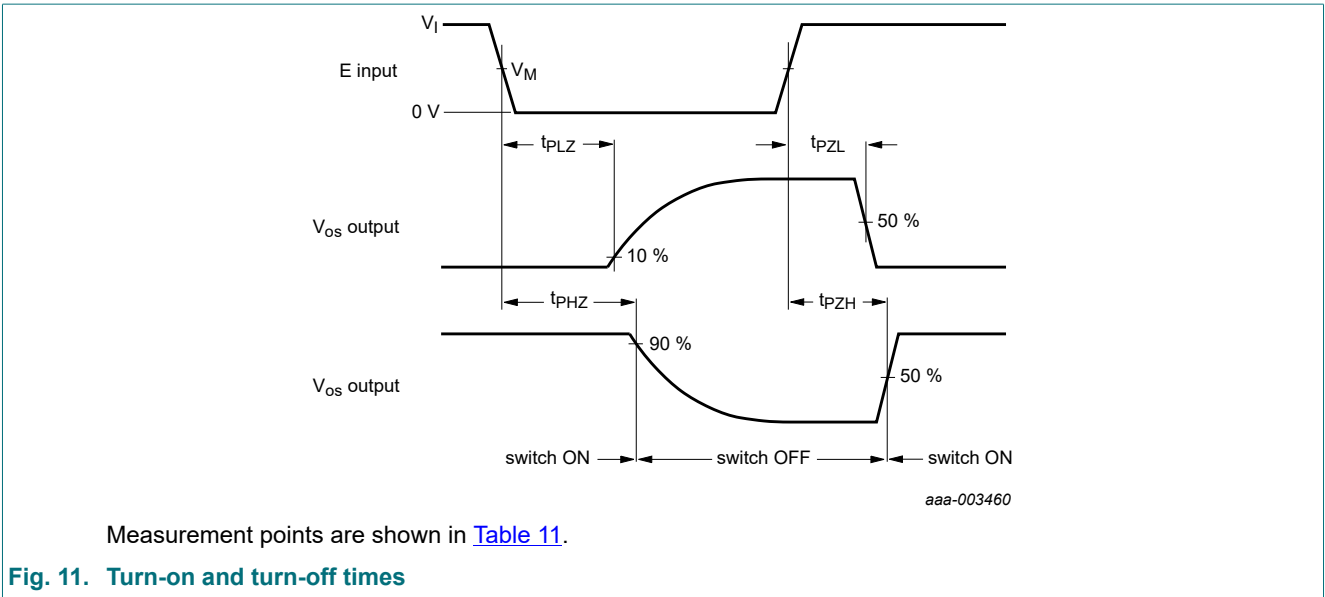

Table 11. Measurement points

Type	V _I	V _M
74HC4066-Q100	V _{CC}	0.5V _{CC}
74HCT4066-Q100	3.0 V	1.3 V

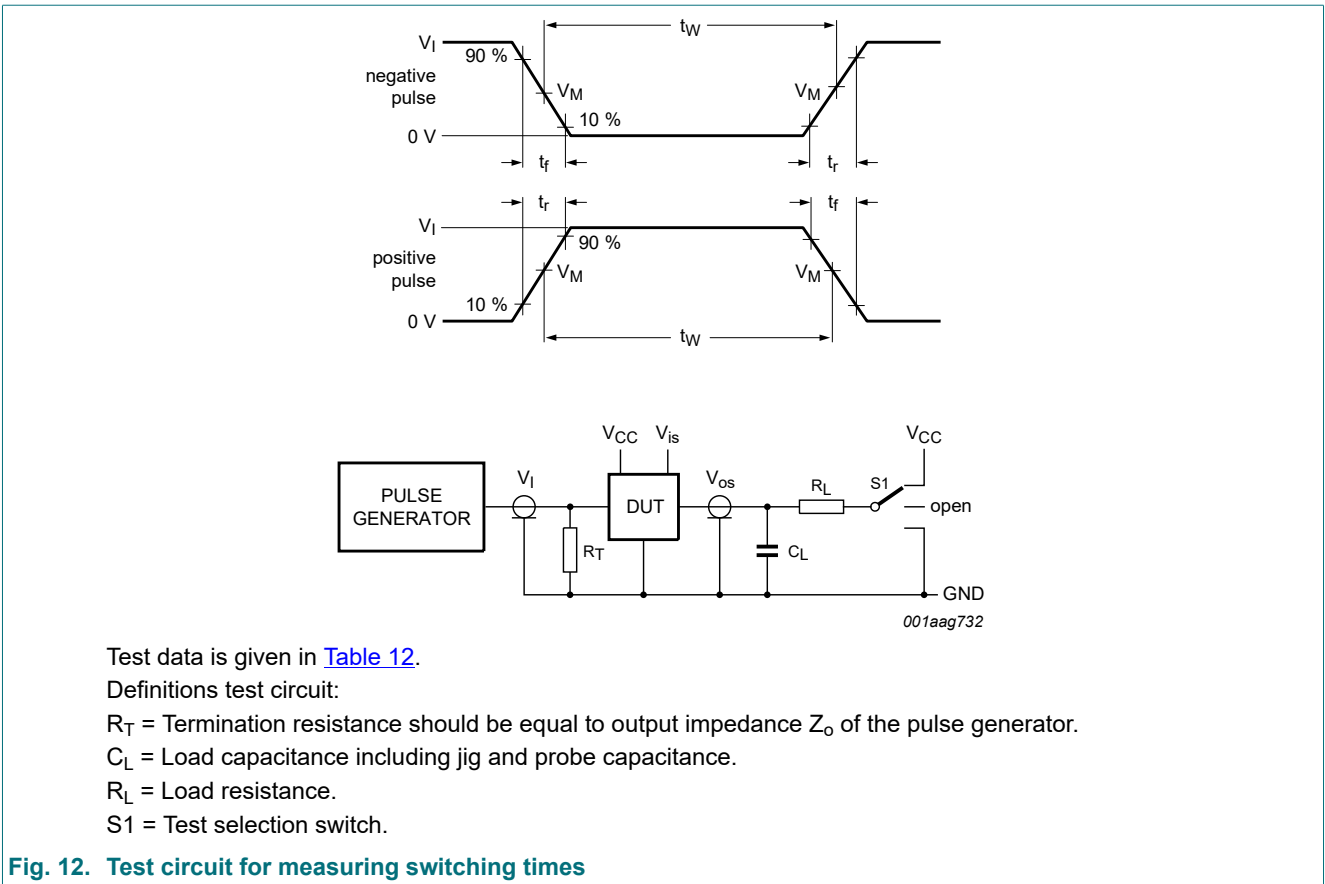

Table 12. Test data

Test	Input			Output		S1 position
	Control E	Switch Yn (Z)	t_r, t_f	Switch Z (Yn)		
	V_i [1]	V_{is}		C_L	R_L	
t_{PHL}, t_{PLH}	GND	GND to V_{CC}	6 ns	50 pF	-	open
t_{PHZ}, t_{PZH}	GND to V_{CC}	V_{CC}	6 ns	50 pF, 15 pF	1 k Ω	GND
t_{PLZ}, t_{PZL}	GND to V_{CC}	GND	6 ns	50 pF, 15 pF	1 k Ω	V_{CC}

[1] For 74HCT4066-Q100: maximum input voltage $V_i = 3.0$ V.

11. Additional dynamic characteristics

Table 13. Additional dynamic characteristics

Recommended conditions and typical values; GND = 0 V; $T_{amb} = 25$ °C.

V_{is} is the input voltage at a Yn or Z terminal, whichever is assigned as an input.

V_{os} is the output voltage at a Yn or Z terminal, whichever is assigned as an output.

Symbol	Parameter	Conditions	Min	Typ	Max	Unit
THD	total harmonic distortion	$f_i = 1$ kHz; $R_L = 10$ k Ω ; $C_L = 50$ pF; see Fig. 13				%
		$V_{CC} = 4.5$ V; $V_i = 4.0$ V (p-p)	-	0.04	-	%
		$V_{CC} = 9.0$ V; $V_i = 8.0$ V (p-p)	-	0.02	-	%
		$f_i = 10$ kHz; $R_L = 10$ k Ω ; $C_L = 50$ pF; see Fig. 13				
		$V_{CC} = 4.5$ V; $V_i = 4.0$ V (p-p)	-	0.12	-	%
		$V_{CC} = 9.0$ V; $V_i = 8.0$ V (p-p)	-	0.06	-	%
$f_{(-3dB)}$	-3 dB frequency response	$R_L = 50$ Ω ; $C_L = 10$ pF; see Fig. 14 [1]				
		$V_{CC} = 4.5$ V	-	180	-	MHz
		$V_{CC} = 9.0$ V	-	200	-	MHz
α_{iso}	isolation (OFF-state)	$R_L = 600$ Ω ; $C_L = 50$ pF; $f_i = 1$ MHz; see Fig. 15 [2]				
		$V_{CC} = 4.5$ V	-	-50	-	dB
		$V_{CC} = 9.0$ V	-	-50	-	dB
V_{ct}	crosstalk voltage	between digital input and switch (peak to peak value); $R_L = 600$ Ω ; $C_L = 50$ pF; $f_i = 1$ MHz; see Fig. 16				
		$V_{CC} = 4.5$ V	-	110	-	mV
		$V_{CC} = 9.0$ V	-	220	-	mV
Xtalk	crosstalk	between switches; $R_L = 600$ Ω ; $C_L = 50$ pF; $f_i = 1$ MHz; see Fig. 17 [2]				
		$V_{CC} = 4.5$ V	-	-60	-	dB
		$V_{CC} = 9.0$ V	-	-60	-	dB

[1] Adjust input voltage V_{is} to 0 dBm level at V_{os} for $f_i = 1$ MHz (0 dBm = 1 mW into 50 Ω). After set-up, f_i is increased to obtain a reading of -3 dB at V_{os} .

[2] Adjust input voltage V_{is} to 0 dBm level (0 dBm = 1 mW into 600 Ω).

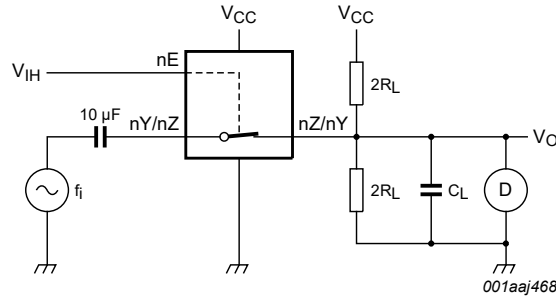
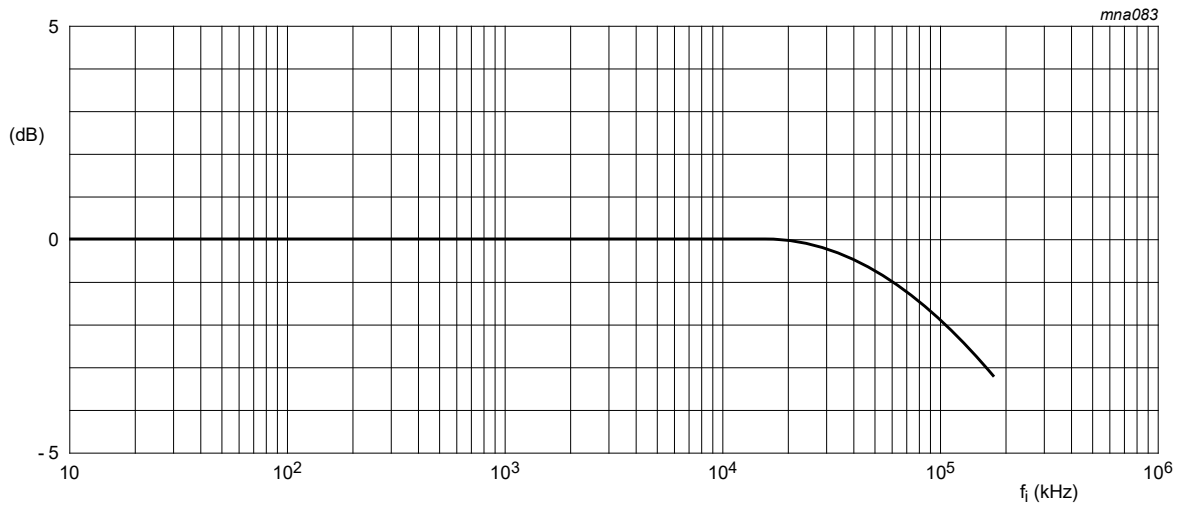
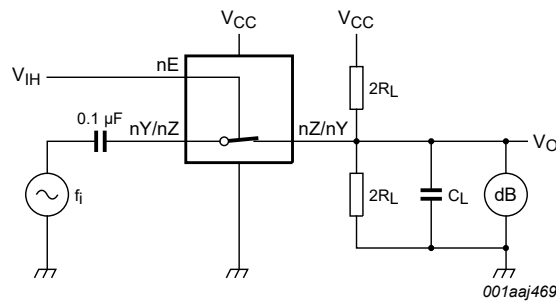

Fig. 13. Test circuit for measuring total harmonic distortion



a. Typical -3 dB frequency response



b. Test circuit

$V_{CC} = 4.5 \text{ V}$; $GND = 0 \text{ V}$; $R_L = 50 \text{ } \Omega$; $R_{source} = 1 \text{ k}\Omega$.

Fig. 14. -3 dB frequency response as a function of frequency

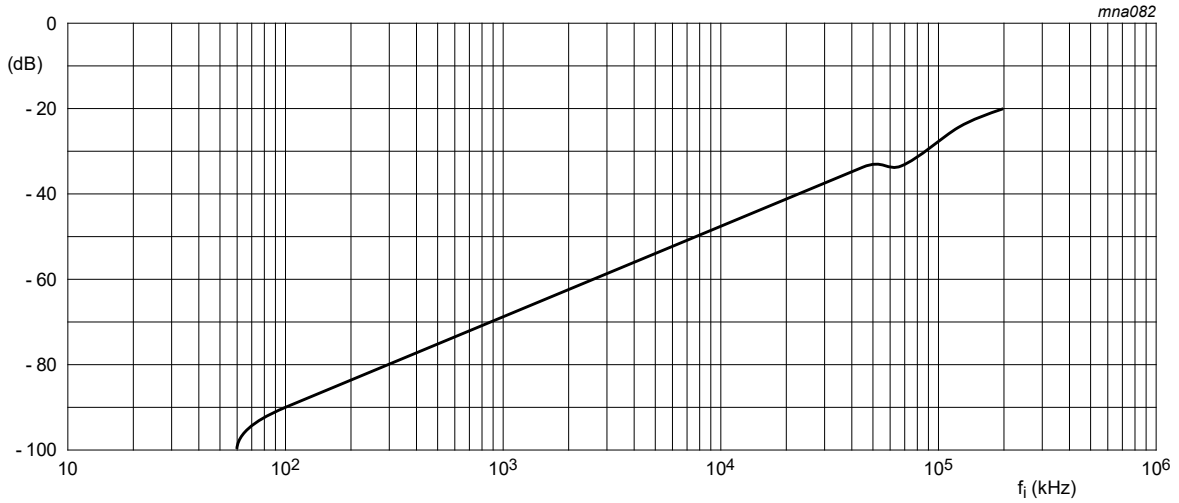

a. Isolation (OFF-state)

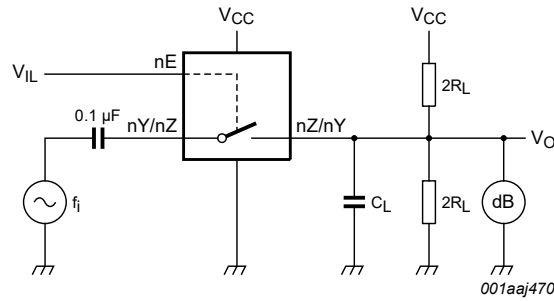

b. Test circuit

$V_{CC} = 4.5\text{ V}$; $GND = 0\text{ V}$; $R_L = 600\ \Omega$; $R_{source} = 1\text{ k}\Omega$.

Fig. 15. Isolation (OFF-state) as a function of frequency

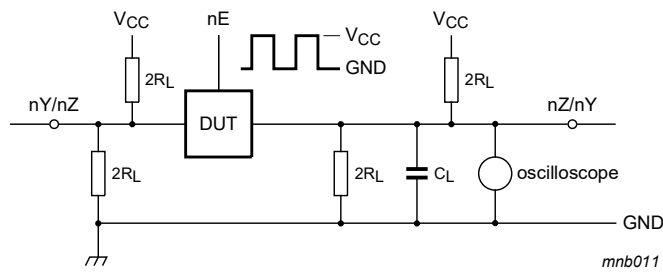

a. Test circuit

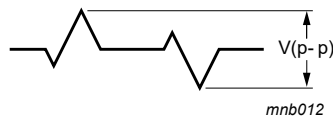

b. Crosstalk voltage

Fig. 16. Test circuit for measuring crosstalk voltage (between the digital input and the switch)

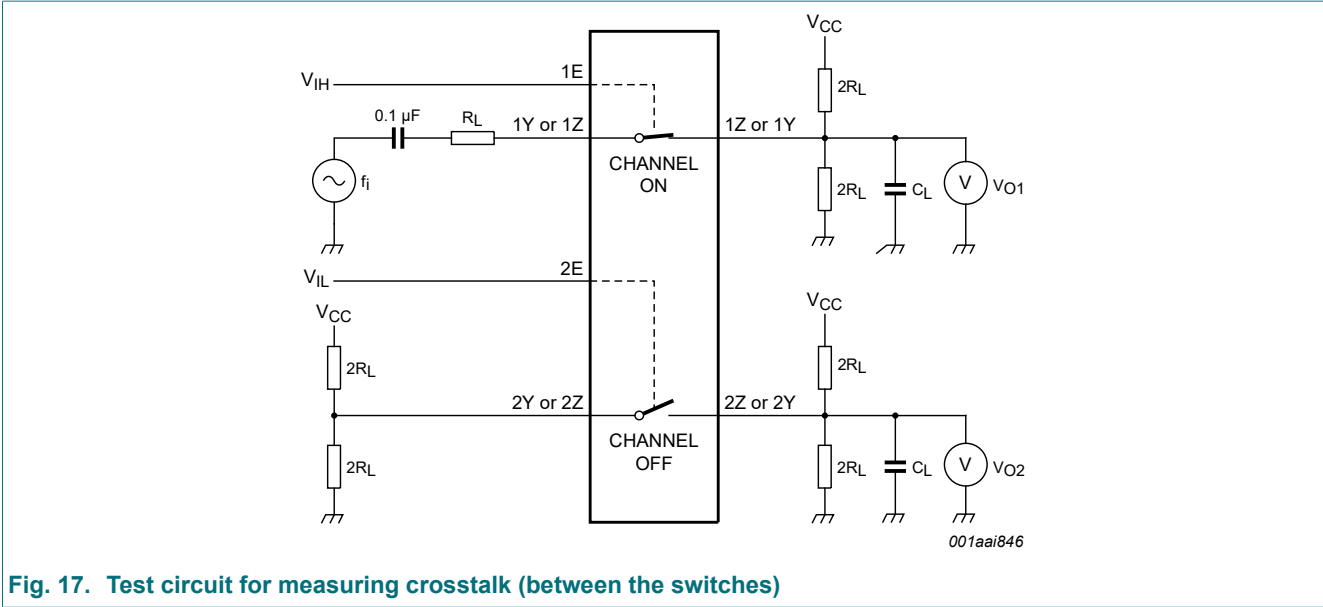

Fig. 17. Test circuit for measuring crosstalk (between the switches)

12. Package outline

SO14: plastic small outline package; 14 leads; body width 3.9 mm

SOT108-1

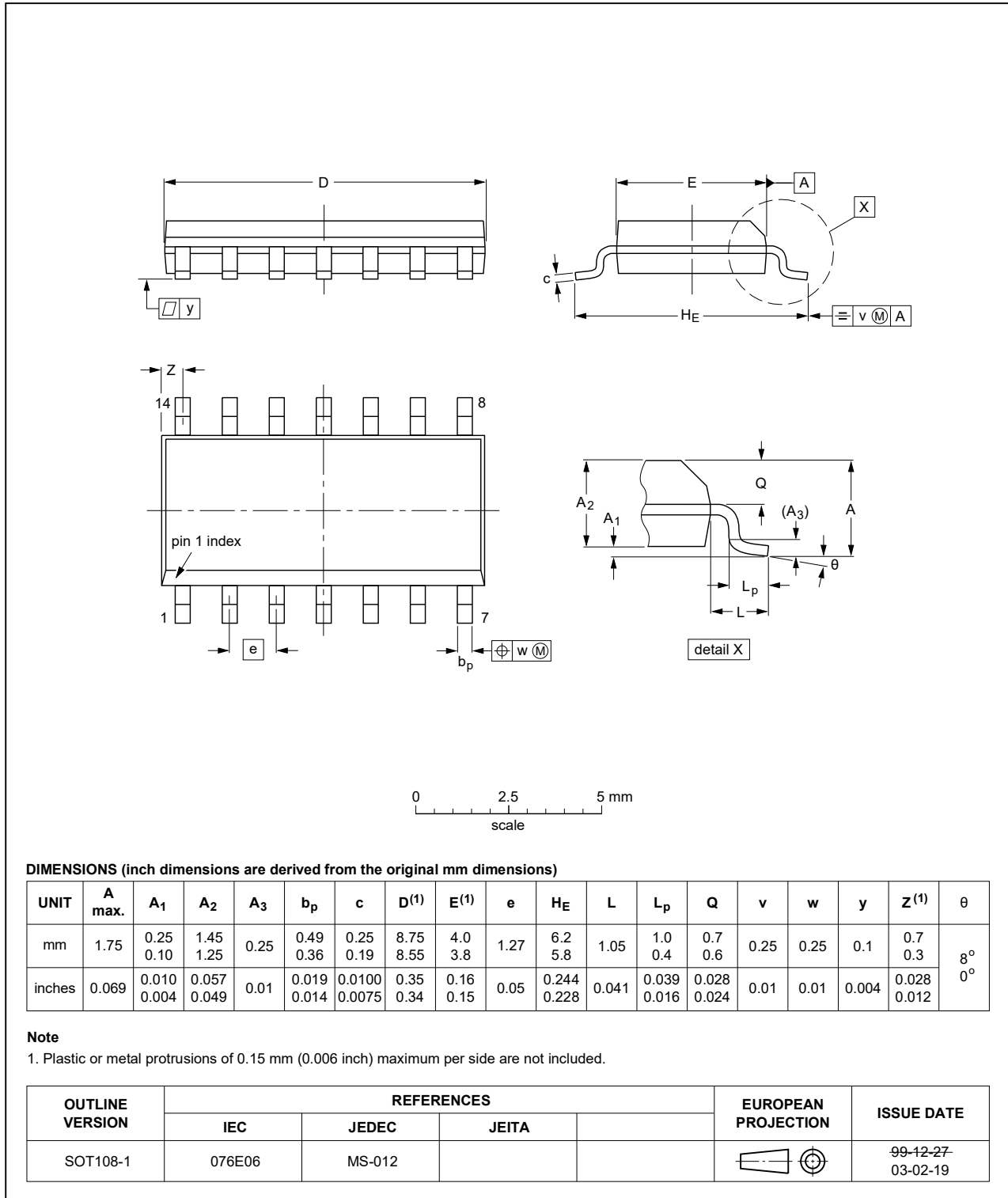

Fig. 18. Package outline SOT108-1 (SO14)

TSSOP14: plastic thin shrink small outline package; 14 leads; body width 4.4 mm

SOT402-1

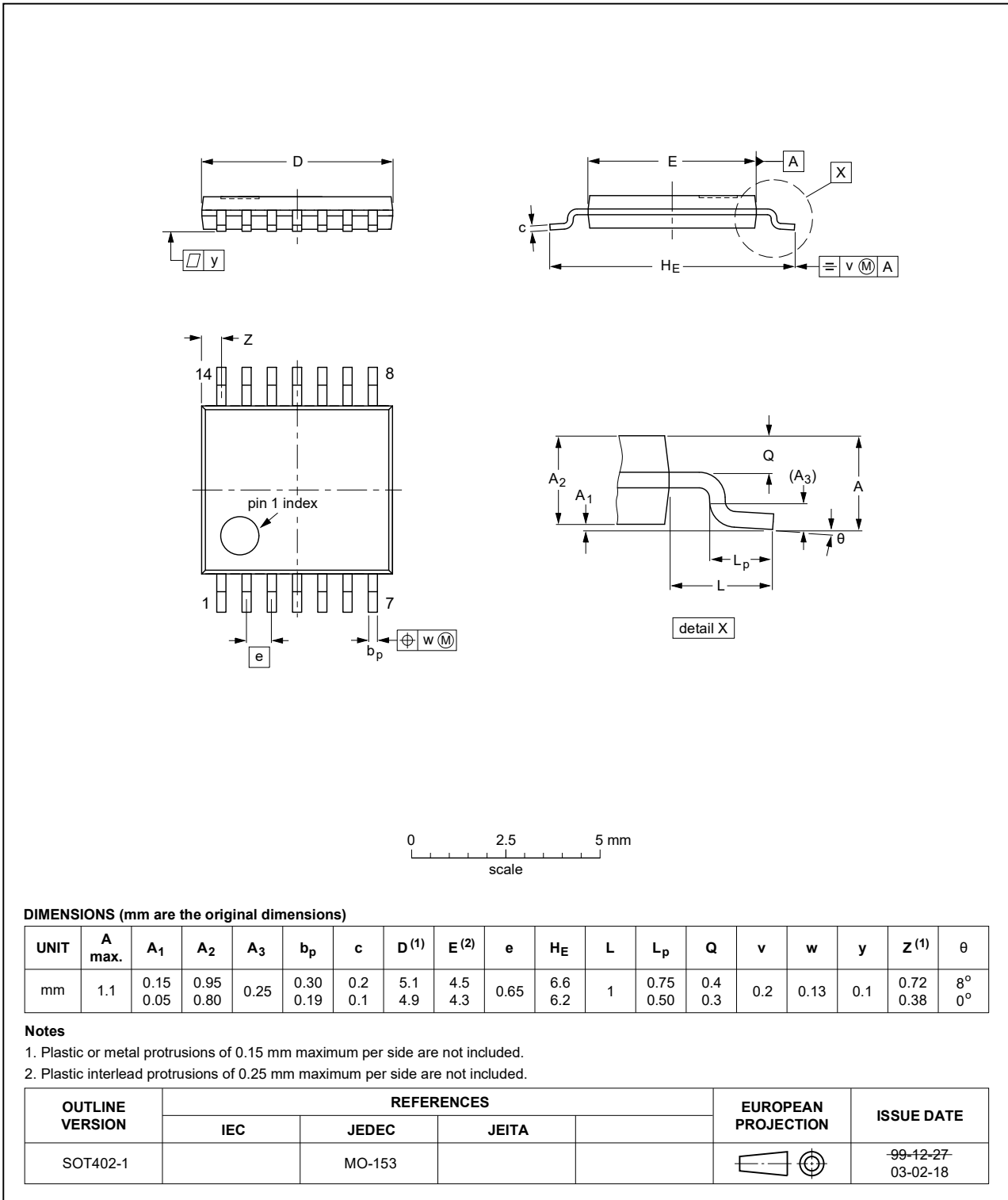

Fig. 19. Package outline SOT402-1 (TSSOP14)

DHVQFN14: plastic dual in-line compatible thermal enhanced very thin quad flat package; no leads;
14 terminals; body 2.5 x 3 x 0.85 mm

SOT762-1

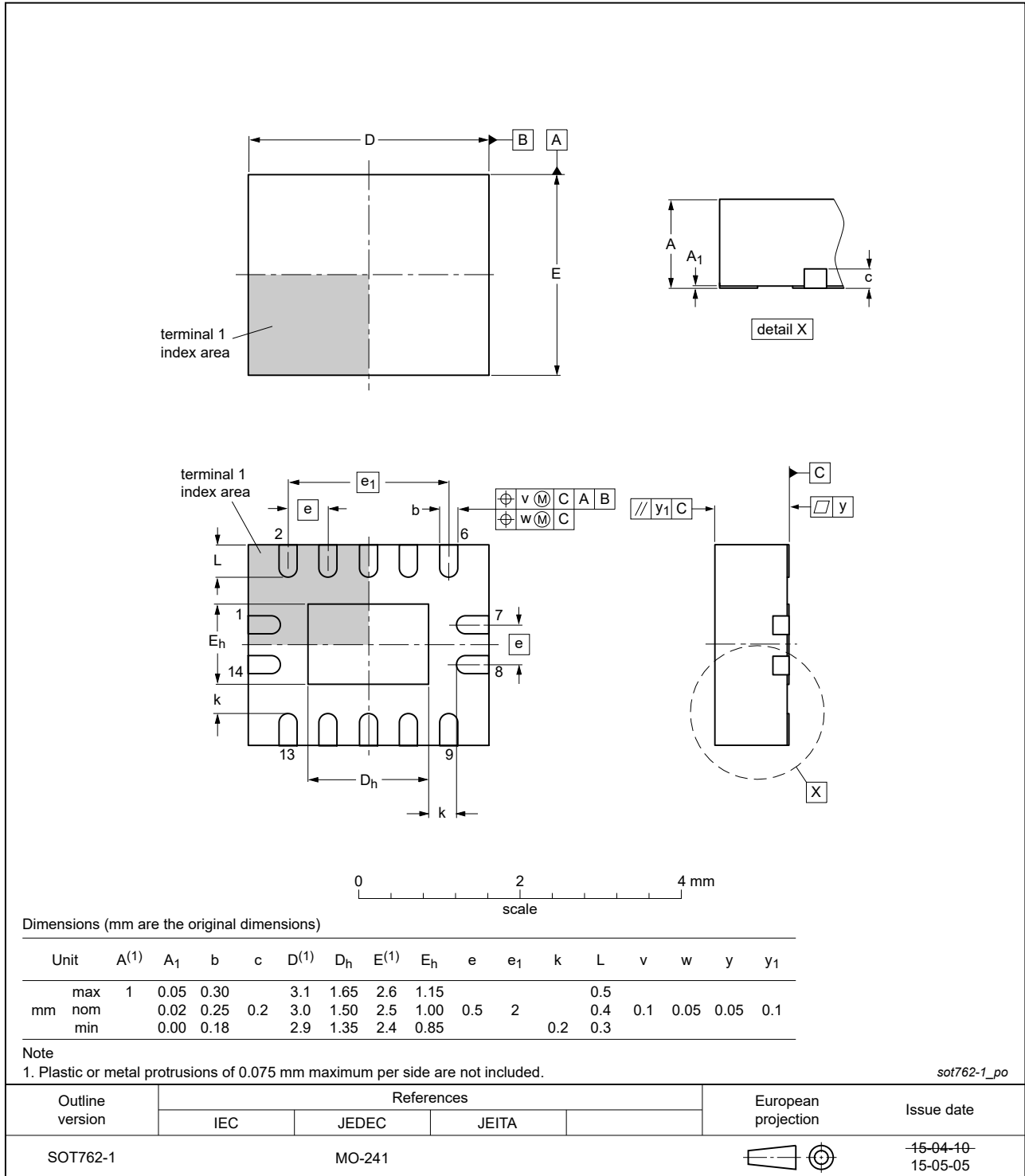

Fig. 20. Package outline SOT762-1 (DHVQFN14)

13. Abbreviations

Table 14. Abbreviations

Acronym	Description
CMOS	Complementary Metal-Oxide Semiconductor
DUT	Device Under Test
ESD	ElectroStatic Discharge
HBM	Human Body Model
MIL	Military
MM	Machine Model
TTL	Transistor-Transistor Logic

14. Revision history

Table 15. Revision history

Document ID	Release date	Data sheet status	Change notice	Supersedes
74HC_HCT4066_Q100 v.4	20200414	Product data sheet	-	74HC_HCT4066_Q100 v.3
Modifications:	<ul style="list-style-type: none"> The format of this data sheet has been redesigned to comply with the identity guidelines of Nexperia. Legal texts have been adapted to the new company name where appropriate. Table 4: Derating values for P_{tot} total power dissipation have been updated. Table 9: C_{PD} value of 74HC4066-Q100 moved to typical column. Package outline drawing of SOT762-1 (Fig. 20) updated. 			
74HC_HCT4066_Q100 v.3	20131216	Product data sheet	-	74HC_HCT4066_Q100 v.2
Modifications:	<ul style="list-style-type: none"> Features and benefits updated (errata). 			
74HC_HCT4066_Q100 v.2	20130404	Product data sheet	-	74HC_HCT4066_Q100 v.1
Modifications:	<ul style="list-style-type: none"> Descriptive title corrected (errata). New general description (errata). 			
74HC_HCT4066_Q100 v.1	20120712	Product data sheet	-	-

15. Legal information

Data sheet status

Document status [1][2]	Product status [3]	Definition
Objective [short] data sheet	Development	This document contains data from the objective specification for product development.
Preliminary [short] data sheet	Qualification	This document contains data from the preliminary specification.
Product [short] data sheet	Production	This document contains the product specification.

- [1] Please consult the most recently issued document before initiating or completing a design.
- [2] The term 'short data sheet' is explained in section "Definitions".
- [3] The product status of device(s) described in this document may have changed since this document was published and may differ in case of multiple devices. The latest product status information is available on the internet at <https://www.nexperia.com>.

Definitions

Draft — The document is a draft version only. The content is still under internal review and subject to formal approval, which may result in modifications or additions. Nexperia does not give any representations or warranties as to the accuracy or completeness of information included herein and shall have no liability for the consequences of use of such information.

Short data sheet — A short data sheet is an extract from a full data sheet with the same product type number(s) and title. A short data sheet is intended for quick reference only and should not be relied upon to contain detailed and full information. For detailed and full information see the relevant full data sheet, which is available on request via the local Nexperia sales office. In case of any inconsistency or conflict with the short data sheet, the full data sheet shall prevail.

Product specification — The information and data provided in a Product data sheet shall define the specification of the product as agreed between Nexperia and its customer, unless Nexperia and customer have explicitly agreed otherwise in writing. In no event however, shall an agreement be valid in which the Nexperia product is deemed to offer functions and qualities beyond those described in the Product data sheet.

Disclaimers

Limited warranty and liability — Information in this document is believed to be accurate and reliable. However, Nexperia does not give any representations or warranties, expressed or implied, as to the accuracy or completeness of such information and shall have no liability for the consequences of use of such information. Nexperia takes no responsibility for the content in this document if provided by an information source outside of Nexperia.

In no event shall Nexperia be liable for any indirect, incidental, punitive, special or consequential damages (including - without limitation - lost profits, lost savings, business interruption, costs related to the removal or replacement of any products or rework charges) whether or not such damages are based on tort (including negligence), warranty, breach of contract or any other legal theory.

Notwithstanding any damages that customer might incur for any reason whatsoever, Nexperia's aggregate and cumulative liability towards customer for the products described herein shall be limited in accordance with the Terms and conditions of commercial sale of Nexperia.

Right to make changes — Nexperia reserves the right to make changes to information published in this document, including without limitation specifications and product descriptions, at any time and without notice. This document supersedes and replaces all information supplied prior to the publication hereof.

Suitability for use in automotive applications — This Nexperia product has been qualified for use in automotive applications. Unless otherwise agreed in writing, the product is not designed, authorized or warranted to be suitable for use in life support, life-critical or safety-critical systems or

equipment, nor in applications where failure or malfunction of an Nexperia product can reasonably be expected to result in personal injury, death or severe property or environmental damage. Nexperia and its suppliers accept no liability for inclusion and/or use of Nexperia products in such equipment or applications and therefore such inclusion and/or use is at the customer's own risk.

Quick reference data — The Quick reference data is an extract of the product data given in the Limiting values and Characteristics sections of this document, and as such is not complete, exhaustive or legally binding.

Applications — Applications that are described herein for any of these products are for illustrative purposes only. Nexperia makes no representation or warranty that such applications will be suitable for the specified use without further testing or modification.

Customers are responsible for the design and operation of their applications and products using Nexperia products, and Nexperia accepts no liability for any assistance with applications or customer product design. It is customer's sole responsibility to determine whether the Nexperia product is suitable and fit for the customer's applications and products planned, as well as for the planned application and use of customer's third party customer(s). Customers should provide appropriate design and operating safeguards to minimize the risks associated with their applications and products.

Nexperia does not accept any liability related to any default, damage, costs or problem which is based on any weakness or default in the customer's applications or products, or the application or use by customer's third party customer(s). Customer is responsible for doing all necessary testing for the customer's applications and products using Nexperia products in order to avoid a default of the applications and the products or of the application or use by customer's third party customer(s). Nexperia does not accept any liability in this respect.

Limiting values — Stress above one or more limiting values (as defined in the Absolute Maximum Ratings System of IEC 60134) will cause permanent damage to the device. Limiting values are stress ratings only and (proper) operation of the device at these or any other conditions above those given in the Recommended operating conditions section (if present) or the Characteristics sections of this document is not warranted. Constant or repeated exposure to limiting values will permanently and irreversibly affect the quality and reliability of the device.

Terms and conditions of commercial sale — Nexperia products are sold subject to the general terms and conditions of commercial sale, as published at <http://www.nexperia.com/profile/terms>, unless otherwise agreed in a valid written individual agreement. In case an individual agreement is concluded only the terms and conditions of the respective agreement shall apply. Nexperia hereby expressly objects to applying the customer's general terms and conditions with regard to the purchase of Nexperia products by customer.

No offer to sell or license — Nothing in this document may be interpreted or construed as an offer to sell products that is open for acceptance or the grant, conveyance or implication of any license under any copyrights, patents or other industrial or intellectual property rights.

Export control — This document as well as the item(s) described herein may be subject to export control regulations. Export might require a prior authorization from competent authorities.

Translations — A non-English (translated) version of a document is for reference only. The English version shall prevail in case of any discrepancy between the translated and English versions.

Trademarks

Notice: All referenced brands, product names, service names and trademarks are the property of their respective owners.

Contents

1. General description	1
2. Features and benefits	1
3. Ordering information	1
4. Functional diagram	2
5. Pinning information	2
5.1. Pinning.....	2
5.2. Pin description.....	3
6. Functional description	3
7. Limiting values	3
8. Recommended operating conditions	4
9. Static characteristics	4
10. Dynamic characteristics	8
10.1. Waveforms and test circuit.....	9
11. Additional dynamic characteristics	11
12. Package outline	15
13. Abbreviations	17
14. Revision history	18
15. Legal information	19

© Nexperia B.V. 2020. All rights reserved

For more information, please visit: <http://www.nexperia.com>

For sales office addresses, please send an email to: salesaddresses@nexperia.com

Date of release: 14 April 2020

X-ON Electronics

Largest Supplier of Electrical and Electronic Components

Click to view similar products for [Analogue Switch ICs](#) category:

Click to view products by [Nexperia](#) manufacturer:

Other Similar products are found below :

[FSA3051TMX](#) [NLAS4684FCTCG](#) [NLAS5223BLMNR2G](#) [NLVAS4599DTT1G](#) [NLX2G66DMUTCG](#) [425541DB](#) [425528R](#) [099044FB](#)
[NLAS5123MNR2G](#) [PI5A4157CEX](#) [PI5A4599BCEX](#) [NLAS4717EPFCT1G](#) [PI5A3167CCEX](#) [SLAS3158MNR2G](#) [PI5A392AQE](#)
[PI5A4157ZUEX](#) [PI5A3166TAEX](#) [FSA634UCX](#) [TC4066BP\(N,F\)](#) [DG302BDJ-E3](#) [PI5A100QEX](#) [HV2605FG-G](#) [HV2301FG-G](#)
[RS2117YUTQK10](#) [RS2118YUTQK10](#) [RS2227XUTQK10](#) [ADG452BRZ-REEL7](#) [MAX4066ESD+](#) [MAX391CPE+](#) [MAX4730EXT+T](#)
[MAX314CPE+](#) [BU4066BCFV-E2](#) [MAX313CPE+](#) [BU4S66G2-TR](#) [NLAS3158MNR2G](#) [NLASB3157MTR2G](#) [TS3A4751PWR](#)
[NLAS4157DFT2G](#) [NLAS4599DFT2G](#) [NLASB3157DFT2G](#) [NLAST4599DFT2G](#) [NLAST4599DTT1G](#) [DG300BDJ-E3](#) [DG2503DB-T2-GE1](#)
[DG2502DB-T2-GE1](#) [TC4W53FU\(TE12L,F\)](#) [74HC2G66DC.125](#) [ADG619BRMZ-REEL](#) [ADG1611BRUZ-REEL7](#) [LTC201ACN#PBF](#)