

HEF4007UB

Dual complementary pair and inverter

Rev. 4 — 31 August 2017

Product data sheet

1 General description

The HEF4007UB is a dual complementary pair and an inverter with access to each device. It has three n-channel and three p-channel enhancement mode MOS transistors.

It operates over a recommended V_{DD} power supply range of 3 V to 15 V referenced to V_{SS} (usually ground). Unused inputs must be connected to V_{DD} , V_{SS} , or another input.

2 Features and benefits

- Fully static operation
- 5 V, 10 V, and 15 V parametric ratings
- Standardized symmetrical output characteristics
- Specified from $-40\text{ }^{\circ}\text{C}$ to $+85\text{ }^{\circ}\text{C}$
- Complies with JEDEC standard JESD 13-B
- Inputs and outputs are protected against electrostatic effects

3 Ordering information

Table 1. Ordering information

Type number	Package	Temperature range	Name	Description	Version
HEF4007UBT		$-40\text{ }^{\circ}\text{C}$ to $+85\text{ }^{\circ}\text{C}$	SO14	plastic small outline package; 14 leads; body width 3.9 mm	SOT108-1

4 Functional diagram

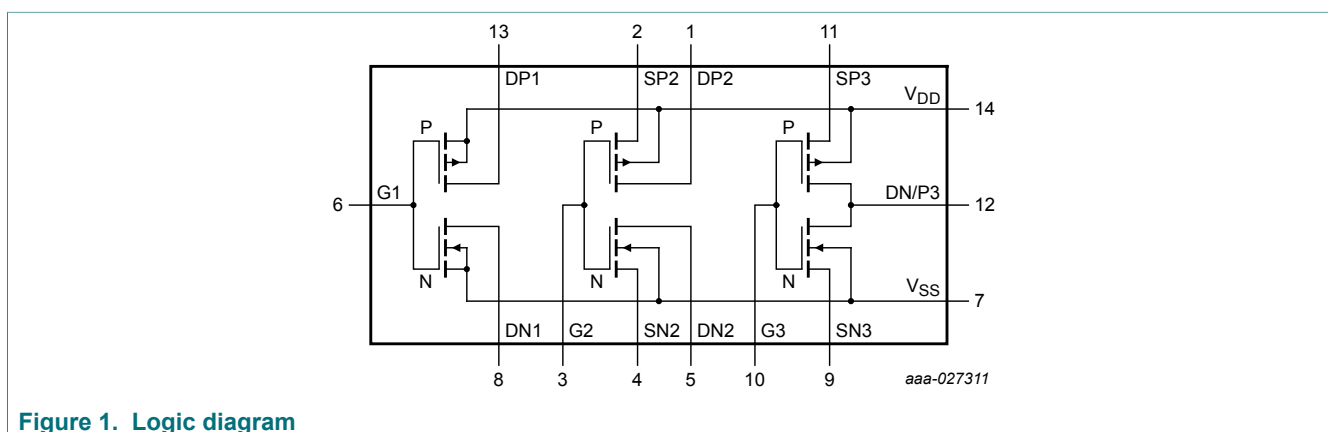
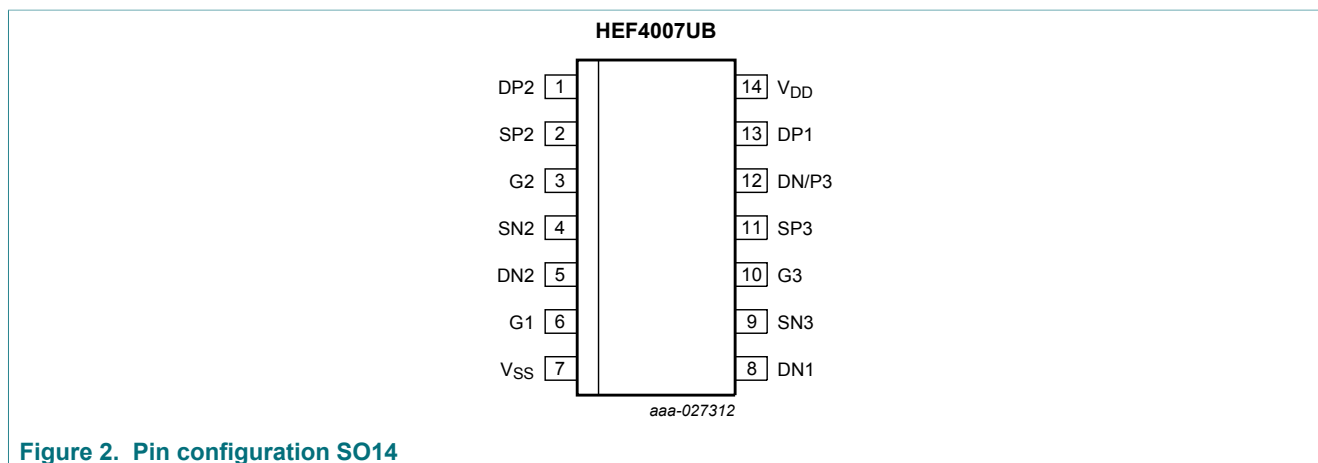

Figure 1. Logic diagram

5 Pinning information

5.1 Pinning



5.2 Pin description

Table 2. Pin description

Symbol	Pin	Description
DP1, DP2	13, 1	drain connections from the 1st and 2nd p-channel transistors
SP2, SP3	2, 11	source connections to 2nd and 3rd p-channel transistors
G1, G2, G3	6, 3, 10	gate connections to n-channel and p-channel of the three transistor pairs
SN2, SN3	4, 9	source connections to the 2nd and 3rd n-channel transistors
DN1, DN2	8, 5	drain connection from the 1st and 2nd n-channel transistors
DN/P3	12	common connection to the 3rd p-channel and n-channel transistor drains
V _{SS}	7	ground (0 V)
V _{DD}	14	supply voltage

6 Limiting values

Table 3. Limiting values

In accordance with the Absolute Maximum Rating System (IEC 60134). Voltages are referenced to $V_{SS} = 0\text{ V}$ (ground).

Symbol	Parameter	Conditions	Min	Max	Unit
V_{DD}	supply voltage		-0.5	+18	V
I_{IK}	input clamping current		-	± 10	mA
V_I	input voltage		-0.5	$V_{DD} + 0.5$	V
I_{OK}	output clamping current		-	± 10	mA
$I_{I/O}$	input/output current		-	± 10	mA
I_{DD}	supply current		-	50	mA
T_{stg}	storage temperature		-65	+150	°C
T_{amb}	ambient temperature		-40	+85	°C
P_{tot}	total power dissipation	$T_{amb} = -40\text{ °C to } +85\text{ °C}$			
		SO14 [1]	-	500	mW
P	power dissipation	per output	-	100	mW

[1] For SO14 packages: above $T_{amb} = 70\text{ °C}$, P_{tot} derates linearly with 8 mW/K.

7 Recommended operating conditions

Table 4. Recommended operating conditions

Symbol	Parameter	Conditions	Min	Typ	Max	Unit
V_{DD}	supply voltage		3	-	15	V
V_I	input voltage		0	-	V_{DD}	V
T_{amb}	ambient temperature	in free air	-40	-	+85	°C
$\Delta t/\Delta V$	input transition rise and fall rate	$V_{DD} = 5\text{ V}$	-	-	3.75	$\mu\text{s/V}$
		$V_{DD} = 10\text{ V}$	-	-	0.5	$\mu\text{s/V}$
		$V_{DD} = 15\text{ V}$	-	-	0.08	$\mu\text{s/V}$

8 Static characteristics

Table 5. Static characteristics
 $V_{SS} = 0\text{ V}$; $V_I = V_{SS}$ or V_{DD} ; unless otherwise specified.

Symbol	Parameter	Conditions	V_{DD}	$T_{amb} = -40\text{ °C}$		$T_{amb} = +25\text{ °C}$		$T_{amb} = +85\text{ °C}$		Unit
				Min	Max	Min	Max	Min	Max	
V_{IH}	HIGH-level input voltage	$V_O = 0.5\text{ V}$ or 4.5 V ; $ I_O < 1\text{ }\mu\text{A}$	5 V	4	-	4	-	4	-	V
		$V_O = 1.0\text{ V}$ or 9.0 V ; $ I_O < 1\text{ }\mu\text{A}$	10 V	8	-	8	-	8	-	V
		$V_O = 1.5\text{ V}$ or 13.5 V ; $ I_O < 1\text{ }\mu\text{A}$	15 V	12.5	-	12.5	-	12.5	-	V
V_{IL}	LOW-level input voltage	$V_O = 0.5\text{ V}$ or 4.5 V ; $ I_O < 1\text{ }\mu\text{A}$	5 V	-	1	-	1	-	1	V
		$V_O = 1.0\text{ V}$ or 9.0 V ; $ I_O < 1\text{ }\mu\text{A}$	10 V	-	2	-	2	-	2	V
		$V_O = 1.5\text{ V}$ or 13.5 V ; $ I_O < 1\text{ }\mu\text{A}$	15 V	-	2.5	-	2.5	-	2.5	V
V_{OH}	HIGH-level output voltage	$V_I = V_{SS}$ or V_{DD} ; $ I_O < 1\text{ }\mu\text{A}$	5 V	4.95	-	4.95	-	4.95	-	V
			10 V	9.95	-	9.95	-	9.95	-	V
			15 V	14.95	-	14.95	-	14.95	-	V
V_{OL}	LOW-level output voltage	$V_I = V_{SS}$ or V_{DD} ; $ I_O < 1\text{ }\mu\text{A}$	5 V	-	0.05	-	0.05	-	0.05	V
			10 V	-	0.05	-	0.05	-	0.05	V
			15 V	-	0.05	-	0.05	-	0.05	V
I_{OH}	HIGH-level output (source) current	$V_O = 2.5\text{ V}$; $V_I = 0\text{ V}$	5 V	-	-1.7	-	-1.4	-	-1.1	mA
		$V_O = 4.6\text{ V}$; $V_I = 0\text{ V}$	5 V	-	-0.52	-	-0.44	-	-0.36	mA
		$V_O = 9.5\text{ V}$; $V_I = 0\text{ V}$	10 V	-	-1.3	-	-1.1	-	-0.9	mA
		$V_O = 13.5\text{ V}$; $V_I = 0\text{ V}$	15 V	-	-3.6	-	-3.0	-	-2.4	mA
I_{OL}	LOW-level output (sink) current	$V_O = 0.4\text{ V}$; $V_I = 5\text{ V}$	5 V	0.52	-	0.44	-	0.36	-	mA
		$V_O = 0.5\text{ V}$; $V_I = 10\text{ V}$	10 V	1.3	-	1.1	-	0.9	-	mA
		$V_O = 1.5\text{ V}$; $V_I = 15\text{ V}$	15 V	3.6	-	3.0	-	2.4	-	mA
I_I	input leakage current	$V_I = 0\text{ V}$ to 15 V	15 V	-	± 0.3	-	± 0.3	-	± 1.0	μA
I_{DD}	supply current	all valid input combinations; $V_I = V_{SS}$ or V_{DD} ; $I_O = 0\text{ A}$	5 V	-	1.0	-	1.0	-	7.5	μA
			10 V	-	2.0	-	2.0	-	15.0	μA
			15 V	-	4.0	-	4.0	-	30.0	μA

9 Dynamic characteristics

Table 6. Dynamic characteristics

$T_{amb} = 25\text{ }^{\circ}\text{C}$; for waveforms see [Figure 3](#); for test circuit see [Figure 4](#); unless otherwise specified.

Symbol	Parameter	Conditions	Extrapolation formula ^[1]	V _{DD}	Min	Typ	Max	Unit
t _{PHL}	HIGH to LOW propagation delay	Gn to Dn or DP	$13 + 0.55 \times C_L$	5 V	-	40	80	ns
			$9 + 0.23 \times C_L$	10 V	-	20	40	ns
			$7 + 0.16 \times C_L$	15 V	-	15	30	ns
t _{PLH}	LOW to HIGH propagation delay	Gn to Dn or DP	$13 + 0.55 \times C_L$	5 V	-	40	75	ns
			$9 + 0.23 \times C_L$	10 V	-	20	40	ns
			$7 + 0.16 \times C_L$	15 V	-	15	30	ns
t _t	output transition time ^[2]		$10 + 1.0 \times C_L$	5 V	-	60	120	ns
			$9 + 0.42 \times C_L$	10 V	-	30	60	ns
			$6 + 0.28 \times C_L$	15 V	-	20	40	ns

[1] The typical value of the propagation delay and output transition time can be calculated with the extrapolation formula (C_L in pF).

[2] t_t is the same as t_{T_{HL}} and t_{T_{LH}}.

Table 7. Dynamic power dissipation

$V_{SS} = 0\text{ V}$; $t_r = t_f \leq 20\text{ ns}$; $T_{amb} = 25\text{ }^{\circ}\text{C}$.

Symbol	Parameter	V _{DD}	Typical formula	Where
P _D	dynamic power dissipation	5 V	$P_D = 4500 \times f_i + \Sigma(f_o \times C_L) \times V_{DD}^2$ (μW)	f _i = input frequency in MHz; f _o = output frequency in MHz; C _L = output load capacitance in pF; Σ(f _o × C _L) = sum of the outputs; V _{DD} = supply voltage in V.
		10 V	$P_D = 20000 \times f_i + \Sigma(f_o \times C_L) \times V_{DD}^2$ (μW)	
		15 V	$P_D = 50000 \times f_i + \Sigma(f_o \times C_L) \times V_{DD}^2$ (μW)	

9.1 Waveforms and test circuit

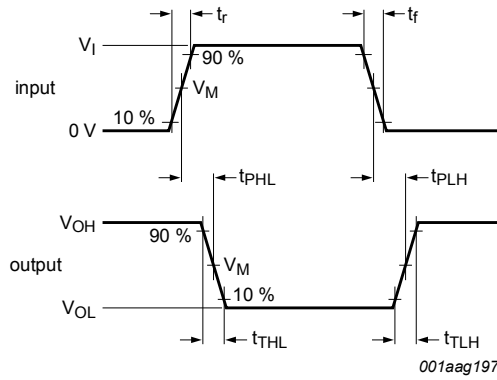

Measurement points are given in [Table 8](#).

Logic levels: V_{OL} and V_{OH} are typical output voltage levels that occur with the output load.

Figure 3. Propagation delay, output transition time

Table 8. Measurement points

Supply voltage	Input	Output
V_{DD}	V_M	V_M
5 V to 15 V	$0.5V_{DD}$	$0.5V_{DD}$

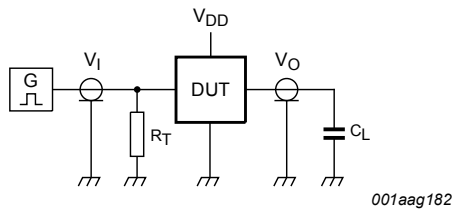

Test data is given in [Table 9](#).

Definitions for test circuit:

C_L = load capacitance including jig and probe capacitance.

R_T = termination resistance should be equal to the output impedance Z_o of the pulse generator.

Figure 4. Test circuit for measuring switching times

Table 9. Test data

Supply voltage	Input	Load
V_{DD}	V_I	C_L
5 V to 15 V	V_{SS} or V_{DD}	≤ 20 ns
		50 pF

9.2 Characteristics

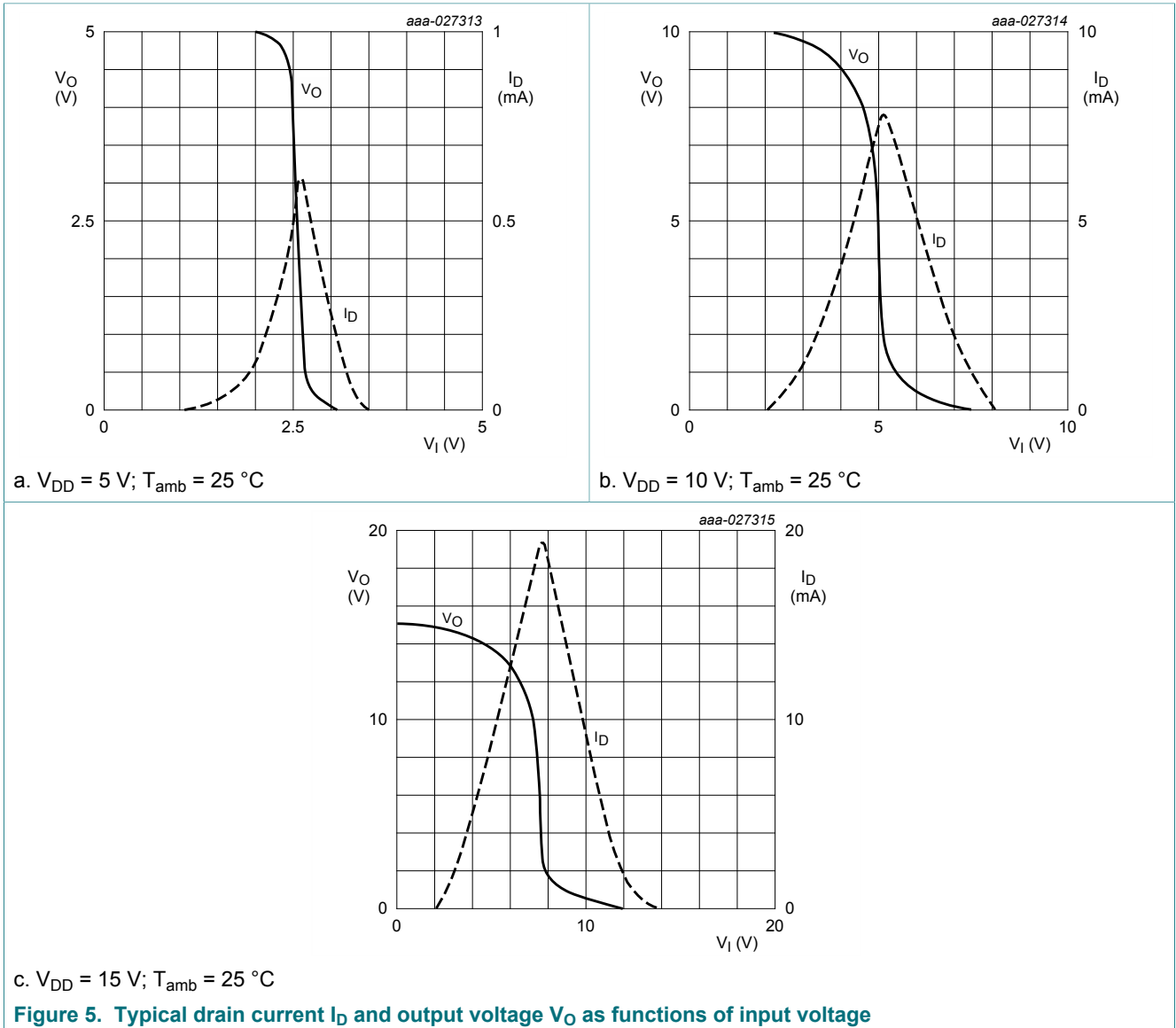

10 Application information

Some examples of applications for the HEF4007UB are:

- High input impedance amplifiers
- Linear amplifiers
- (Crystal) oscillators
- High-current sink and source drivers
- High impedance buffers

Note:

Rules for maintaining electrical isolation between transistors and monolithic substrate:

- The V_{DD} supply pin (Pin 14) must be maintained at the most positive (or equally positive) potential with respect to any other pin of the HEF4007UB.
- The V_{SS} ground pin (Pin 7) must be maintained at the most positive (or equally positive) potential with respect to any other pin of the HEF4007UB.

Violation of these rules will result in improper transistor operation and/or possible permanent damage to the HEF4007UB.

Figure 6 and Figure 7 show voltage gain and supply current. Figure 8 shows the test set-up and an example of an analog amplifier using one HEF4007UB.

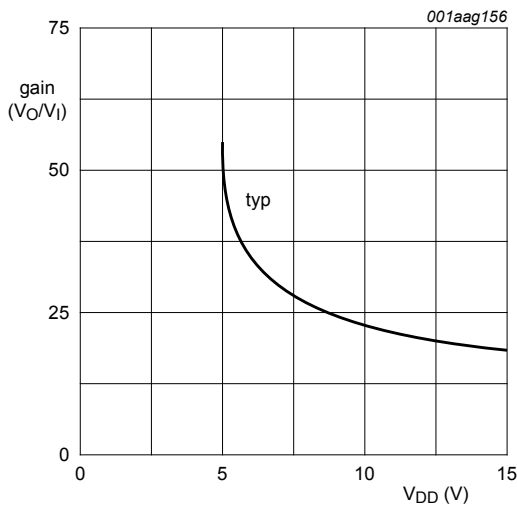

Figure 6. Typical voltage gain as a function of supply voltage

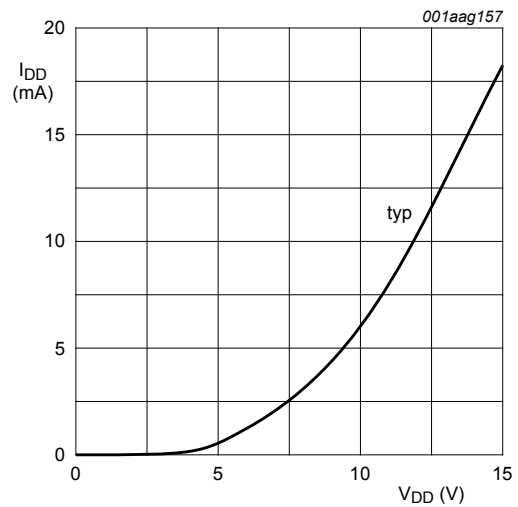

Figure 7. Typical supply current as a function of supply voltage

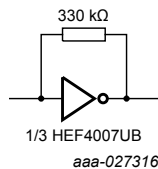

Figure 8. Test set-up

Figure 9 shows typical forward transconductance and Figure 10 shows the test set-up.

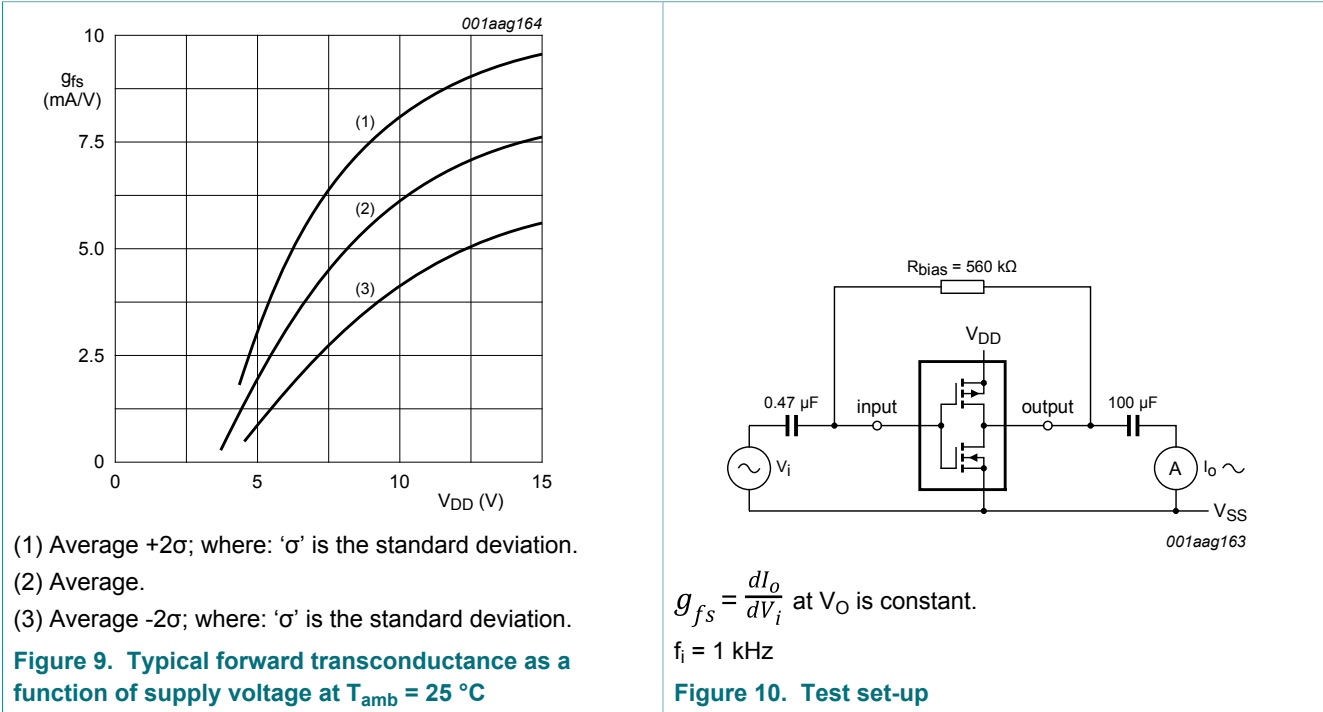
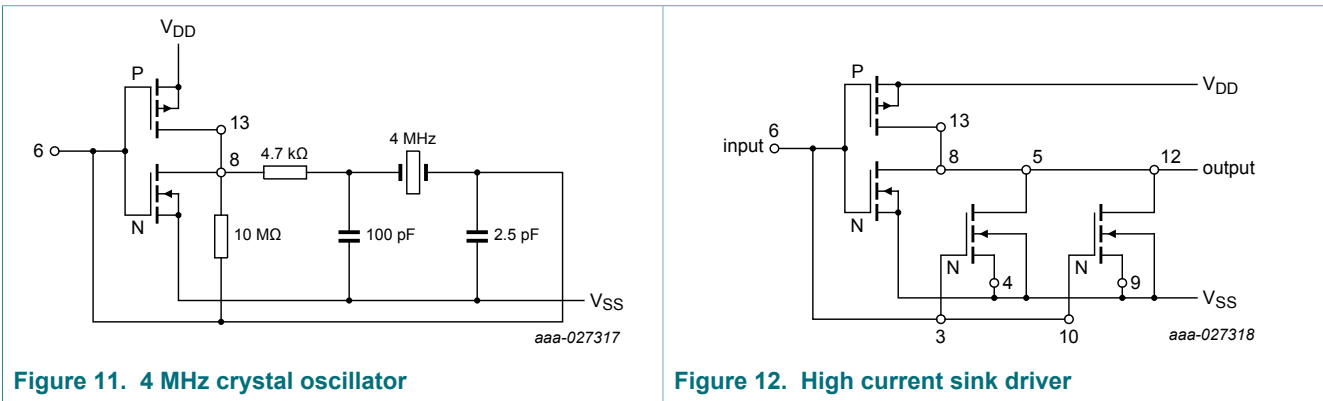

Figure 11, Figure 12, Figure 13 and Figure 14 show some applications in which the HEF4007UB is used.



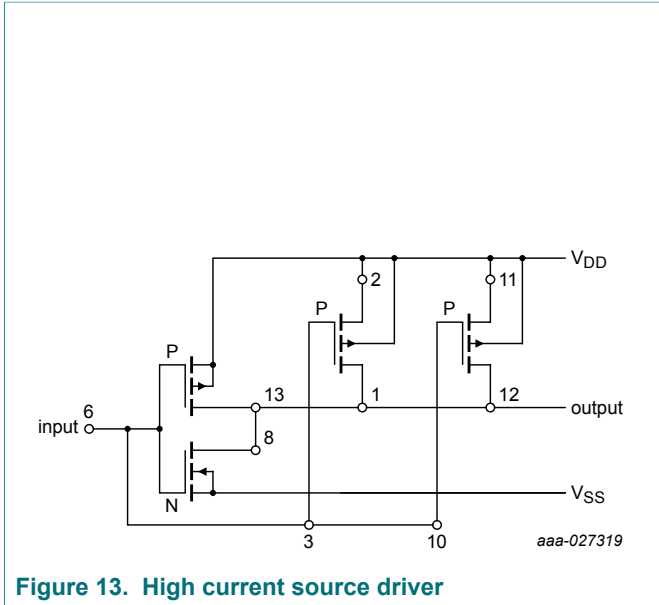

Figure 13. High current source driver

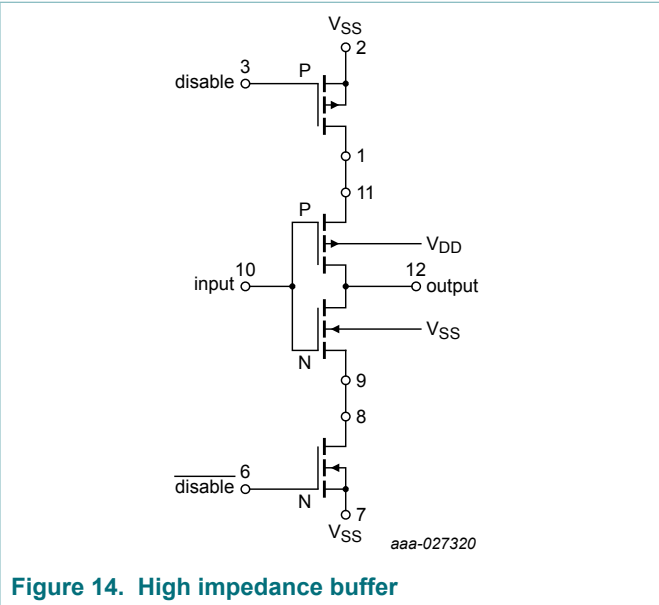

Figure 14. High impedance buffer

Table 10. Function table [1]

For Figure 14. High impedance buffer

Input	Disable	Output
H	L	L
L	L	H
X	H	Z

[1] H = HIGH state (the more positive voltage);
 L = LOW state (the less positive voltage);
 X = state is immaterial
 Z = HIGH-impedance OFF-state

11 Package outline

SO14: plastic small outline package; 14 leads; body width 3.9 mm

SOT108-1

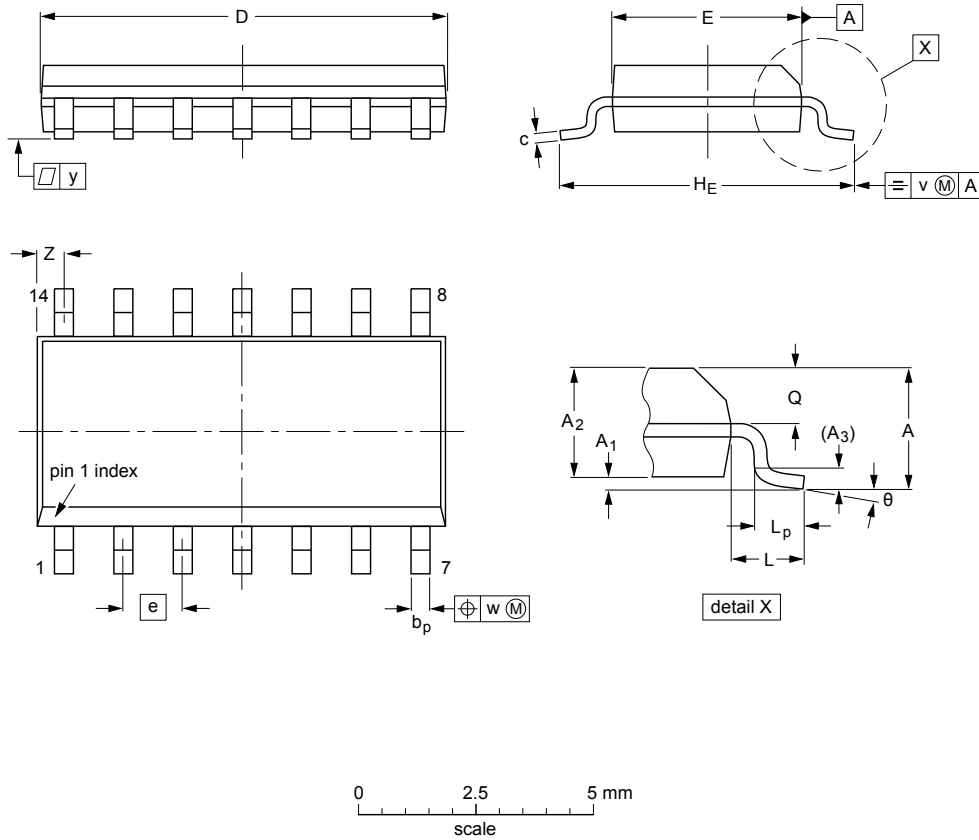

DIMENSIONS (inch dimensions are derived from the original mm dimensions)

UNIT	A max.	A ₁	A ₂	A ₃	b _p	c	D ⁽¹⁾	E ⁽¹⁾	e	H _E	L	L _p	Q	v	w	y	z ⁽¹⁾	θ
mm	1.75	0.25 0.10	1.45 1.25	0.25	0.49 0.36	0.25 0.19	8.75 8.55	4.0 3.8	1.27	6.2 5.8	1.05	1.0 0.4	0.7 0.6	0.25	0.25	0.1	0.7 0.3	8° 0°
inches	0.069	0.010 0.004	0.057 0.049	0.01	0.019 0.014	0.0100 0.0075	0.35 0.34	0.16 0.15	0.05	0.244 0.228	0.041	0.039 0.016	0.028 0.024	0.01	0.01	0.004	0.028 0.012	

Note

1. Plastic or metal protrusions of 0.15 mm (0.006 inch) maximum per side are not included.

OUTLINE VERSION	REFERENCES			EUROPEAN PROJECTION	ISSUE DATE
	IEC	JEDEC	JEITA		
SOT108-1	076E06	MS-012			99-12-27 03-02-19

Figure 15. Package outline SOT108-1 (SO14)

12 Abbreviations

Table 11. Abbreviations

Acronym	Description
DUT	Device Under Test
MOS	Metal Oxide Semiconductor

13 Revision history

Table 12. Revision history

Document ID	Release date	Data sheet status	Change notice	Supersedes
HEF4007UB v.4	20170831	Product data sheet	-	HEF4007UB v.3
Modifications:	<ul style="list-style-type: none">• The format of this data sheet has been redesigned to comply with the identity guidelines of Nexperia.• Legal texts have been adapted to the new company name where appropriate.• Type number HEF4007UBP and HEF4007UBD removed.			
HEF4007UB v.3	19951201	Product specification	-	-

14 Legal information

14.1 Data sheet status

Document status ^{[1][2]}	Product status ^[3]	Definition
Objective [short] data sheet	Development	This document contains data from the objective specification for product development.
Preliminary [short] data sheet	Qualification	This document contains data from the preliminary specification.
Product [short] data sheet	Production	This document contains the product specification.

[1] Please consult the most recently issued document before initiating or completing a design.

[2] The term 'short data sheet' is explained in section "Definitions".

[3] The product status of device(s) described in this document may have changed since this document was published and may differ in case of multiple devices. The latest product status information is available on the Internet at URL <http://www.nexperia.com>.

14.2 Definitions

Draft — The document is a draft version only. The content is still under internal review and subject to formal approval, which may result in modifications or additions. Nexperia does not give any representations or warranties as to the accuracy or completeness of information included herein and shall have no liability for the consequences of use of such information.

Short data sheet — A short data sheet is an extract from a full data sheet with the same product type number(s) and title. A short data sheet is intended for quick reference only and should not be relied upon to contain detailed and full information. For detailed and full information see the relevant full data sheet, which is available on request via the local Nexperia sales office. In case of any inconsistency or conflict with the short data sheet, the full data sheet shall prevail.

Product specification — The information and data provided in a Product data sheet shall define the specification of the product as agreed between Nexperia and its customer, unless Nexperia and customer have explicitly agreed otherwise in writing. In no event however, shall an agreement be valid in which the Nexperia product is deemed to offer functions and qualities beyond those described in the Product data sheet.

14.3 Disclaimers

Limited warranty and liability — Information in this document is believed to be accurate and reliable. However, Nexperia does not give any representations or warranties, expressed or implied, as to the accuracy or completeness of such information and shall have no liability for the consequences of use of such information. Nexperia takes no responsibility for the content in this document if provided by an information source outside of Nexperia. In no event shall Nexperia be liable for any indirect, incidental, punitive, special or consequential damages (including - without limitation - lost profits, lost savings, business interruption, costs related to the removal or replacement of any products or rework charges) whether or not such damages are based on tort (including negligence), warranty, breach of contract or any other legal theory. Notwithstanding any damages that customer might incur for any reason whatsoever, Nexperia's aggregate and cumulative liability towards customer for the products described herein shall be limited in accordance with the Terms and conditions of commercial sale of Nexperia.

Right to make changes — Nexperia reserves the right to make changes to information published in this document, including without limitation specifications and product descriptions, at any time and without notice. This document supersedes and replaces all information supplied prior to the publication hereof.

Suitability for use — Nexperia products are not designed, authorized or warranted to be suitable for use in life support, life-critical or safety-critical

systems or equipment, nor in applications where failure or malfunction of an Nexperia product can reasonably be expected to result in personal injury, death or severe property or environmental damage. Nexperia and its suppliers accept no liability for inclusion and/or use of Nexperia products in such equipment or applications and therefore such inclusion and/or use is at the customer's own risk.

Applications — Applications that are described herein for any of these products are for illustrative purposes only. Nexperia makes no representation or warranty that such applications will be suitable for the specified use without further testing or modification. Customers are responsible for the design and operation of their applications and products using Nexperia products, and Nexperia accepts no liability for any assistance with applications or customer product design. It is customer's sole responsibility to determine whether the Nexperia product is suitable and fit for the customer's applications and products planned, as well as for the planned application and use of customer's third party customer(s). Customers should provide appropriate design and operating safeguards to minimize the risks associated with their applications and products. Nexperia does not accept any liability related to any default, damage, costs or problem which is based on any weakness or default in the customer's applications or products, or the application or use by customer's third party customer(s). Customer is responsible for doing all necessary testing for the customer's applications and products using Nexperia products in order to avoid a default of the applications and the products or of the application or use by customer's third party customer(s). Nexperia does not accept any liability in this respect.

Limiting values — Stress above one or more limiting values (as defined in the Absolute Maximum Ratings System of IEC 60134) will cause permanent damage to the device. Limiting values are stress ratings only and (proper) operation of the device at these or any other conditions above those given in the Recommended operating conditions section (if present) or the Characteristics sections of this document is not warranted. Constant or repeated exposure to limiting values will permanently and irreversibly affect the quality and reliability of the device.

Terms and conditions of commercial sale — Nexperia products are sold subject to the general terms and conditions of commercial sale, as published at <http://www.nexperia.com/profile/terms>, unless otherwise agreed in a valid written individual agreement. In case an individual agreement is concluded only the terms and conditions of the respective agreement shall apply. Nexperia hereby expressly objects to applying the customer's general terms and conditions with regard to the purchase of Nexperia products by customer.

No offer to sell or license — Nothing in this document may be interpreted or construed as an offer to sell products that is open for acceptance or the grant, conveyance or implication of any license under any copyrights, patents or other industrial or intellectual property rights.

Export control — This document as well as the item(s) described herein may be subject to export control regulations. Export might require a prior authorization from competent authorities.

Non-automotive qualified products — Unless this data sheet expressly states that this specific Nexperia product is automotive qualified, the product is not suitable for automotive use. It is neither qualified nor tested in accordance with automotive testing or application requirements. Nexperia accepts no liability for inclusion and/or use of non-automotive qualified products in automotive equipment or applications. In the event that customer uses the product for design-in and use in automotive applications to automotive specifications and standards, customer (a) shall use the product without Nexperia's warranty of the product for such automotive applications, use and specifications, and (b) whenever customer uses the product for automotive applications beyond Nexperia's specifications such use shall be solely at customer's own risk, and (c) customer fully indemnifies Nexperia for any liability, damages or failed product claims resulting from customer

design and use of the product for automotive applications beyond Nexperia's standard warranty and Nexperia's product specifications.

Translations — A non-English (translated) version of a document is for reference only. The English version shall prevail in case of any discrepancy between the translated and English versions.

14.4 Trademarks

Notice: All referenced brands, product names, service names and trademarks are the property of their respective owners.

Contents

1	General description	1
2	Features and benefits	1
3	Ordering information	1
4	Functional diagram	1
5	Pinning information	2
5.1	Pinning	2
5.2	Pin description	2
6	Limiting values	3
7	Recommended operating conditions	3
8	Static characteristics	4
9	Dynamic characteristics	5
9.1	Waveforms and test circuit	6
9.2	Characteristics	7
10	Application information	8
11	Package outline	11
12	Abbreviations	12
13	Revision history	12
14	Legal information	13

Please be aware that important notices concerning this document and the product(s) described herein, have been included in section 'Legal information'.

© Nexperia B.V. 2017.

All rights reserved.

For more information, please visit: <http://www.nexperia.com>

For sales office addresses, please send an email to: salesaddresses@nexperia.com

Date of release: 31 August 2017
Document identifier: HEF4007UB

X-ON Electronics

Largest Supplier of Electrical and Electronic Components

Click to view similar products for [Buffers & Line Drivers](#) category:

Click to view products by [Nexperia](#) manufacturer:

Other Similar products are found below :

[LXV200-024SW](#) [74AUP2G34FW3-7](#) [HEF4043BP](#) [NLU1GT126CMUTCG](#) [PI74FCT3244L](#) [MC74HCT365ADTR2G](#) [Le87401NQC](#)
[Le87402MQC](#) [028192B](#) [042140C](#) [051117G](#) [070519XB](#) [NL17SZ07P5T5G](#) [NLU1GT126AMUTCG](#) [74AUP1G17FW5-7](#) [74LVC2G17FW4-7](#)
[CD4502BE](#) [5962-8982101PA](#) [5962-9052201PA](#) [74LVC1G125FW4-7](#) [NL17SH17P5T5G](#) [74HCT126T14-13](#) [NL17SH125P5T5G](#)
[NLV37WZ07USG](#) [RHRXH162244K1](#) [74AUP1G34FW5-7](#) [74AUP1G07FW5-7](#) [74LVC2G126RA3-7](#) [NLX2G17CMUTCG](#)
[74LVCE1G125FZ4-7](#) [Le87501NQC](#) [74AUP1G126FW5-7](#) [TC74HC4050AP\(F\)](#) [74LVCE1G07FZ4-7](#) [NLX3G16DMUTCG](#)
[NLX2G06AMUTCG](#) [NLU2G17AMUTCG](#) [LE87100NQC](#) [LE87100NQCT](#) [LE87285NQC](#) [LE87285NQCT](#) [LE87290YQC](#) [LE87290YQCT](#)
[LE87511NQC](#) [LE87511NQCT](#) [LE87557NQC](#) [LE87557NQCT](#) [LE87614MQC](#) [LE87614MQCT](#) [LE87286NQCT](#)