

LSF0101

1-bit bidirectional multi-voltage level translator; open-drain;
push-pull

Rev. 2 — 23 September 2020

Product data sheet

1. General description

The LSF0101 is an 1 channel bidirectional multi-voltage level translator for open-drain and push-pull applications. It supports up to 100 MHz up translation and ≥ 100 MHz down translation at ≤ 30 pF capacitive load. There is no need for a direction pin which minimizes system effort. The LSF0101 supports 5 V tolerant I/O pins for compatibility with TTL levels in a variety of applications. The ability to set up different voltage translation levels on each channel makes the device very flexible and suitable for a lot of different applications.

2. Features and benefits

- Bidirectional voltage translation with no direction pin
- Up translation
 - ≤ 100 MHz; $C_L = 30$ pF
 - ≤ 40 MHz; $C_L = 50$ pF
- Down translation
 - ≥ 100 MHz; $C_L = 30$ pF
 - ≤ 40 MHz; $C_L = 50$ pF
- Hot insertion
- Bidirectional voltage level translation between:
 - 0.95 V and 1.8 V, 2.5 V, 3.3 V and 5.0 V
 - 1.2 V and 1.8 V, 2.5 V, 3.3 V and 5.0 V
 - 1.8 V and 2.5 V, 3.3 V and 5.0 V
 - 2.5 V and 3.3 V and 5.0 V
 - 3.3 V and 5.0 V
- Low standby current
- 5 V tolerant I/O pins to support TTL
- Low R_{ON} provides less signal distortion
- High-impedance I/O pins for $EN = Low$.
- Flow-through pinout for easy PCB trace routing.
- Latch-up performance exceeds 100 mA per JESD78 class II level A
- ESD protection:
 - HBM ANSI/ESDA/JEDEC JS-001 exceeds 2000 V
 - CDM ANSI/ESDA/JEDEC JS-002 exceeds 1000 V
- Multiple package options
- Specified from -40 °C to $+125$ °C

3. Applications

- GPIO, MDIO, PMBus, SMBus, SDIO, UART, I²C, and other interfaces in Telecom infrastructure
- Industrial
- Personal computing

4. Ordering information

Table 1. Ordering information

Type number	Package			
	Temperature range	Name	Description	Version
LSF0101GW	-40 °C to +125 °C	SC-88	plastic surface-mounted package; 6 leads	SOT363
LSF0101GM	-40 °C to +125 °C	XSON6	plastic extremely thin small outline package; no leads; 6 terminals; body 1 × 1.45 × 0.5 mm	SOT886
LSF0101GX	-40 °C to +125 °C	X2SON6	plastic thermal enhanced extremely thin small outline package; no leads; 6 terminals; body 1.0 × 0.8 × 0.32 mm	SOT1255-2

5. Marking

Table 2. Marking

Type number	Marking code ^[1]
LSF0101GW	h1
LSF0101GM	h1
LSF0101GX	h1

[1] The pin 1 indicator is located on the lower left corner of the device, below the marking code.

6. Functional diagram

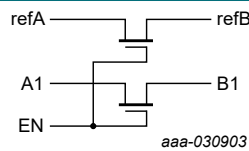

Fig. 1. Logic symbol

7. Pinning information

7.1. Pinning

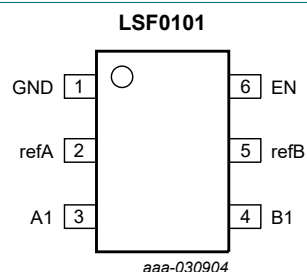

Fig. 2. Pin configuration SOT363 (SC-88)

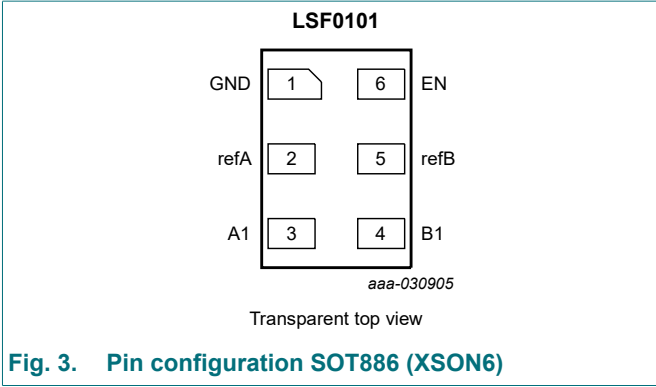

Fig. 3. Pin configuration SOT886 (XSON6)

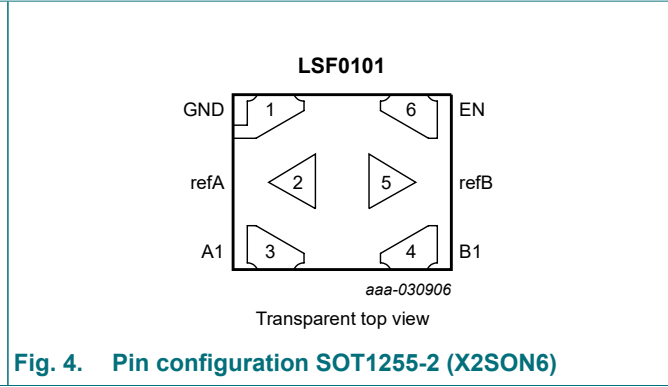

Fig. 4. Pin configuration SOT1255-2 (X2SON6)

7.2. Pin description

Table 3. Pin description

Symbol	Pin	Description
GND	1	ground (0 V)
refA	2	reference voltage A
A1	3	data input/output A
B1	4	data input/output B
refB	5	reference voltage B
EN	6	enable input (active HIGH)

8. Functional description

Table 4. Function table

H = HIGH voltage level; L = LOW voltage level; Z = high-impedance OFF-state.

Input	input/output
EN	A1, B1 channel
H	A1 = B1
L	Z

9. Limiting values

Table 5. Limiting values

In accordance with the Absolute Maximum Rating System (IEC 60134). Voltages are referenced to GND (ground = 0 V).

Symbol	Parameter	Conditions	Min	Max	Unit
V_I	input voltage	pins refA, refB, A1, B1 and EN [1]	-0.5	+7.0	V
$I_{I/O}$	input/output current	pins refA, refB, A1 and B1; continuous channel current	-	+128	mA
I_{IK}	input clamping current	$V_I < 0$ V	-50	-	mA
T_{stg}	storage temperature		-65	+150	°C
P_{tot}	total power dissipation	$T_{amb} = -40$ °C to +125 °C [2]	-	250	mW

[1] The minimum input voltage rating may be exceeded if the input current rating is observed.

[2] For SOT363 (SC-88) package: P_{tot} derates linearly with 3.7 mW/K above 83 °C.
 For SOT886 (XSON6) package: P_{tot} derates linearly with 3.3 mW/K above 74 °C.
 For SOT1255-2 (X2SON6) package: P_{tot} derates linearly with 3.3 mW/K above 75 °C.

10. Recommended operating conditions

Table 6. Recommended operating conditions

Symbol	Parameter	Conditions	Min	Max	Unit
V_I	input voltage	pins refA, refB, A1, B1 and EN	0.0	5.0	V
$I_{I/O}$	input/output current	pins refA, refB, A1 and B1; continuous channel current	-	+64	mA
T_{amb}	ambient temperature		-40	+125	°C

11. Static characteristics

Table 7. Static characteristics

At recommended operating conditions. Voltages are referenced to GND (ground = 0 V).

Symbol	Parameter	Conditions	$T_{amb} = -40\text{ °C to }+125\text{ °C}$			Unit
			Min	Typ[1]	Max	
V_{IK}	input clamping voltage	$V_{EN} = 0\text{ V}; I_I = -18\text{ mA}$	-1.2	-	-	V
I_I	leakage current	pins A1, B1, refA, refB and EN; $V_I = \text{GND to } 5.0\text{ V}$	-	1	5	μA
C_I	input capacitance	pins refA, refB and EN; $V_I = 0\text{ V or } 3\text{ V}$	-	6	-	pF
$C_{iO(off)}$	OFF-state input/output capacitance	pins A1, B1; $V_O = 0\text{ V or } 3\text{ V}; V_{EN} = 0.0\text{ V}$	-	3.7	6.0	pF
$C_{iO(on)}$	ON-state input/output capacitance	pins A1, B1; $V_O = 0\text{ V or } 3\text{ V}; V_{EN} = 3.0\text{ V}$	-	6.0	12.5	pF
R_{ON}	ON resistance	see Fig. 5 [2]				
		$V_I = 0\text{ V}; V_{pu} = 5.0\text{ V}; I_O = 64\text{ mA}$				
		$V_{refA} = 3.3\text{ V}$	-	3	-	Ω
		$V_{refA} = 1.8\text{ V}$	-	4	-	Ω
		$V_{refA} = 1.0\text{ V}$	-	7	-	Ω
		$V_I = 0\text{ V}; V_{pu} = 5.0\text{ V}; I_O = 32\text{ mA}$				
		$V_{refA} = 1.8\text{ V}$	-	4	-	Ω
		$V_{refA} = 2.5\text{ V}$	-	3	-	Ω
		$V_I = 1.8\text{ V}; V_{pu} = 5.0\text{ V}; I_O = 15\text{ mA}$				
		$V_{refA} = 3.3\text{ V}$	-	4	-	Ω
		$V_I = 1.0\text{ V}; V_{pu} = 3.3\text{ V}; I_O = 10\text{ mA}$				
		$V_{refA} = 1.8\text{ V}$	-	7	-	Ω
		$V_I = 0\text{ V}; V_{pu} = 3.3\text{ V}; I_O = 10\text{ mA}$				
		$V_{refA} = 1.0\text{ V}$	-	5	-	Ω
$V_I = 0\text{ V}; V_{pu} = 1.8\text{ V}; I_O = 10\text{ mA}$						
$V_{refA} = 1.0\text{ V}$	-	6	-	Ω		

[1] All typical values are measured at $T_{amb} = 25\text{ °C}$.

[2] Measured by the voltage drop between the An and Bn pins at the indicated current through the switch. ON resistance is determined by the lowest voltage of the two (An or Bn) pins.

1-bit bidirectional multi-voltage level translator; open-drain; push-pull

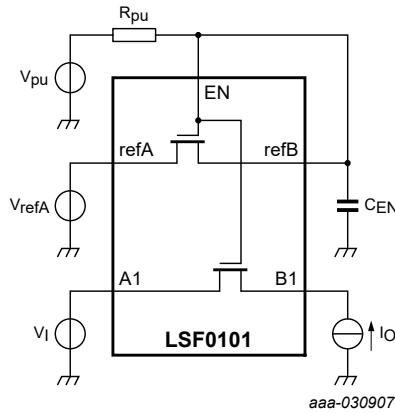

The A1 and B1 pins may be exchanged.
 $R_{pu} = 200 \text{ k}\Omega$
 $C_{EN} = 100 \text{ nF}$

Fig. 5. Test circuit for measuring R_{ON}

12. Dynamic characteristics

Table 8. Switching characteristics

$GND = 0 \text{ V}$; for waveform see Fig. 6; for test circuit see Fig. 7

Symbol	Parameter	Conditions	$T_{amb} = -40 \text{ }^\circ\text{C to } +125 \text{ }^\circ\text{C}$			Unit
			Min	Typ[1]	Max	
Translating down						
t_{PLH}	LOW to HIGH propagation delay	A1 to B1 or B1 to A1; $V_{IH} = V_{pu} = V_{refA} + 1 \text{ V}$				
		$V_{refA} = 1.5 \text{ V}; C_L = 15 \text{ pF}$	-	0.35	-	ns
		$V_{refA} = 1.5 \text{ V}; C_L = 30 \text{ pF}$	-	0.8	-	ns
		$V_{refA} = 1.5 \text{ V}; C_L = 50 \text{ pF}$	-	1.2	-	ns
		$V_{refA} = 2.3 \text{ V}; C_L = 15 \text{ pF}$	-	0.3	-	ns
		$V_{refA} = 2.3 \text{ V}; C_L = 30 \text{ pF}$	-	0.7	-	ns
		$V_{refA} = 2.3 \text{ V}; C_L = 50 \text{ pF}$	-	1.1	-	ns
t_{PHL}	HIGH to LOW propagation delay	A1 to B1 or B1 to A1; $V_{IH} = V_{pu} = V_{refA} + 1 \text{ V}$				
		$V_{refA} = 1.5 \text{ V}; C_L = 15 \text{ pF}$	-	0.5	-	ns
		$V_{refA} = 1.5 \text{ V}; C_L = 30 \text{ pF}$	-	1.0	-	ns
		$V_{refA} = 1.5 \text{ V}; C_L = 50 \text{ pF}$	-	1.3	-	ns
		$V_{refA} = 2.3 \text{ V}; C_L = 15 \text{ pF}$	-	0.4	-	ns
		$V_{refA} = 2.3 \text{ V}; C_L = 30 \text{ pF}$	-	0.8	-	ns
		$V_{refA} = 2.3 \text{ V}; C_L = 50 \text{ pF}$	-	1.2	-	ns

1-bit bidirectional multi-voltage level translator; open-drain; push-pull

Symbol	Parameter	Conditions	T _{amb} = -40 °C to +125 °C			Unit
			Min	Typ[1]	Max	
Translating up						
t _{PLH}	LOW to HIGH propagation delay	A1 to B1 or B1 to A1; V _{IH} = V _{refA} ; V _{EXT} = V _{pu} = V _{refA} + 1 V				
		V _{refA} = 1.5 V; C _L = 15 pF	-	0.5	-	ns
		V _{refA} = 1.5 V; C _L = 30 pF	-	0.9	-	ns
		V _{refA} = 1.5 V; C _L = 50 pF	-	1.1	-	ns
		V _{refA} = 2.3 V; C _L = 15 pF	-	0.4	-	ns
		V _{refA} = 2.3 V; C _L = 30 pF	-	0.8	-	ns
		V _{refA} = 2.3 V; C _L = 50 pF	-	1.0	-	ns
t _{PHL}	HIGH to LOW propagation delay	A1 to B1 or B1 to A1; V _{IH} = V _{refA} ; V _{EXT} = V _{pu} = V _{refA} + 1 V				
		V _{refA} = 1.5 V; C _L = 15 pF	-	0.6	-	ns
		V _{refA} = 1.5 V; C _L = 30 pF	-	1.1	-	ns
		V _{refA} = 1.5 V; C _L = 50 pF	-	1.3	-	ns
		V _{refA} = 2.3 V; C _L = 15 pF	-	0.4	-	ns
		V _{refA} = 2.3 V; C _L = 30 pF	-	0.9	-	ns
		V _{refA} = 2.3 V; C _L = 50 pF	-	1.0	-	ns

[1] All typical values are measured at T_{amb} = 25 °C.

12.1. Waveforms and test circuit

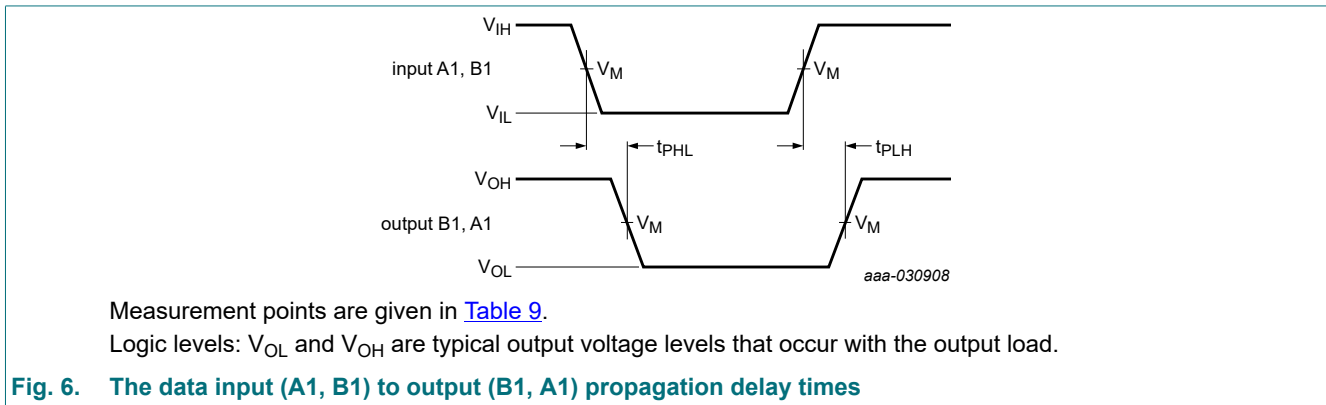

1-bit bidirectional multi-voltage level translator; open-drain; push-pull

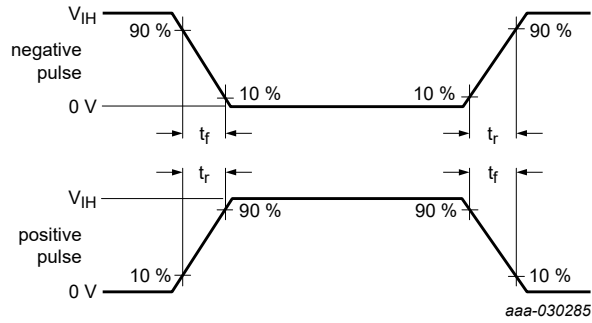

a. V_I source waveform

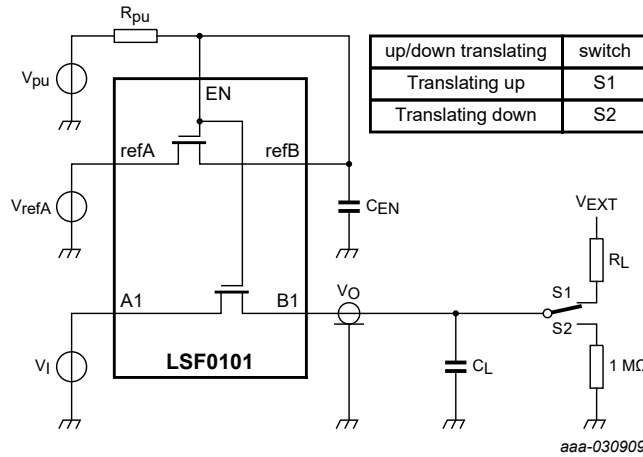

b. Test circuit

Test data is given in [Table 9](#).

The A1 and B1 pins may be exchanged.

All input pulses are supplied by generators having the following characteristics: PRR \leq 10 MHz; $Z_O = 50 \Omega$.

Definitions test circuit:

C_L = Load capacitance including jig and probe capacitance

C_{EN} = Decoupling capacitance

R_{pu} = Pull-up resistance

R_L = Load resistance

S1/S2 = Test selection switch

Fig. 7. Test circuit for measuring switching times

Table 9. Test data

Input		Output	Load			
t_r, t_f	V_M	V_M	C_L	C_{EN} [1]	R_L [1]	R_{pu}
≤ 2 ns	$0.5V_{refA}$	$0.5V_{refA}$	15 pF, 30 pF, 50 pF	100 nF	300 Ω	200 k Ω

[1] All typical values are measured at $T_{amb} = 25 \text{ }^\circ\text{C}$.

13. Package outline

Plastic surface-mounted package; 6 leads

SOT363

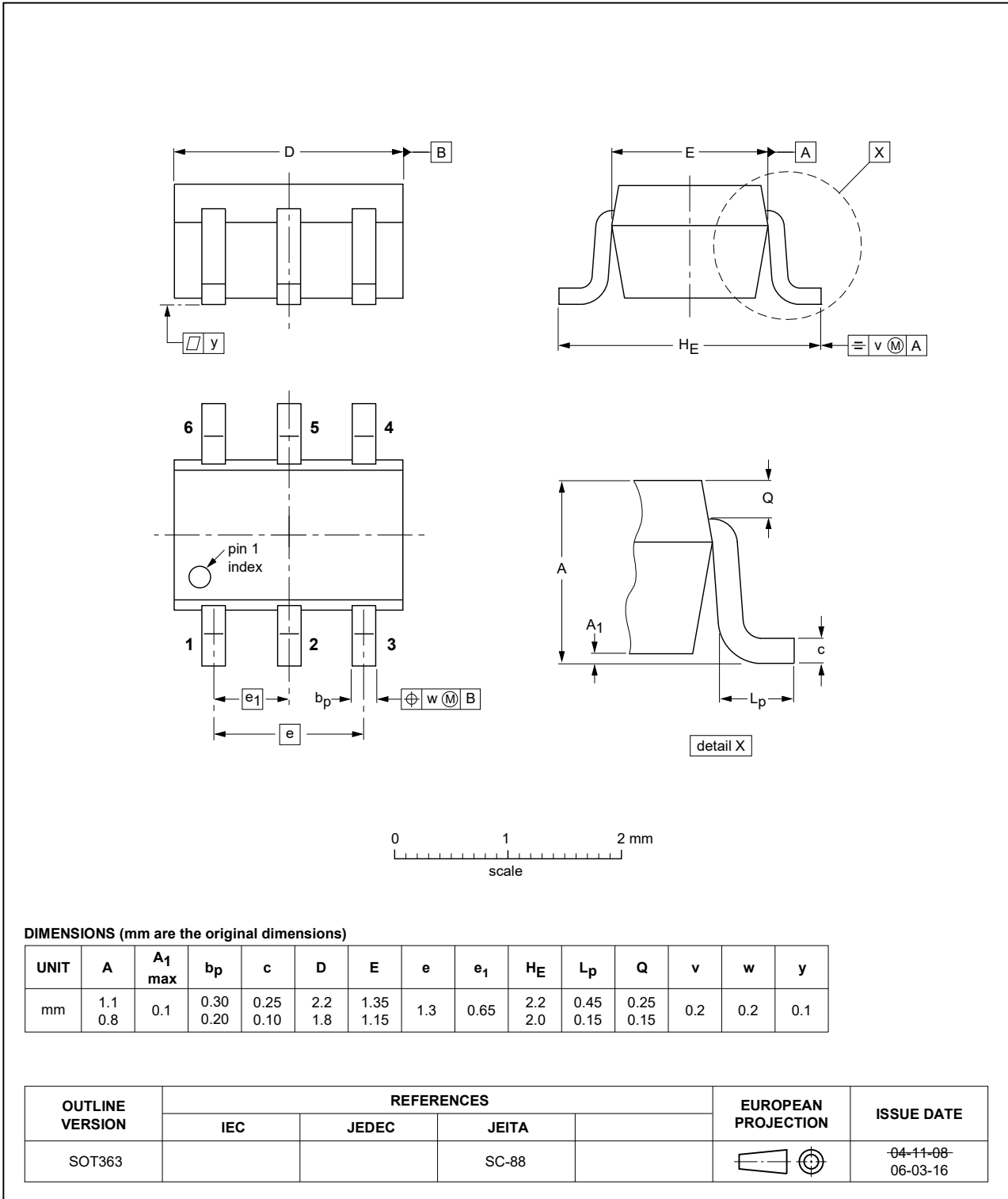

Fig. 8. Package outline SOT363 (SC-88)

1-bit bidirectional multi-voltage level translator; open-drain; push-pull

XSON6: plastic extremely thin small outline package; no leads; 6 terminals; body 1 x 1.45 x 0.5 mm

SOT886

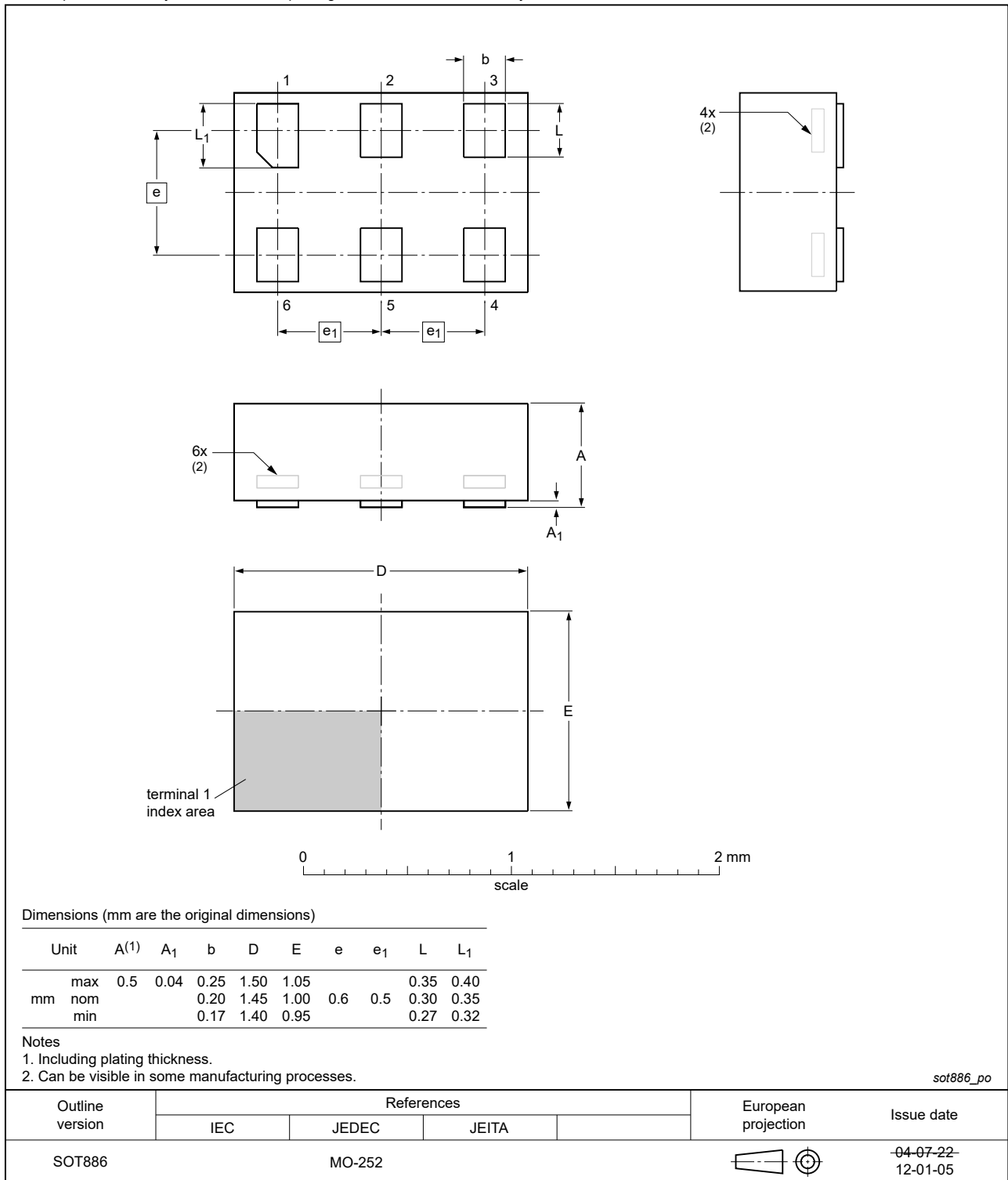

Fig. 9. Package outline SOT886 (XSON6)

1-bit bidirectional multi-voltage level translator; open-drain; push-pull

X2SON6: plastic thermal enhanced extremely thin small outline package; no leads; 6 terminals; body 1.0 x 0.8 x 0.32 mm

SOT1255-2

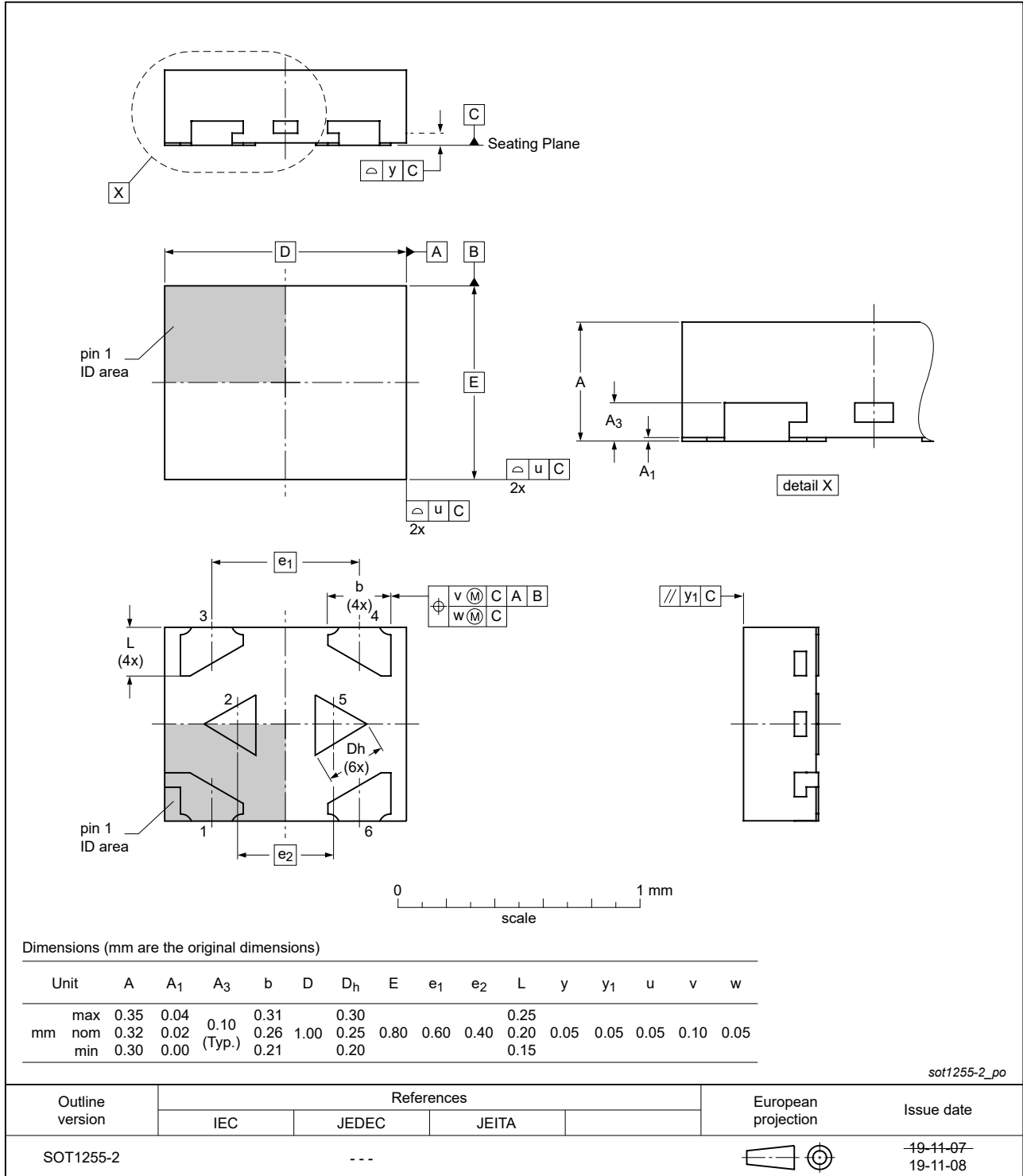

Fig. 10. Package outline SOT1255-2 (X2SON6)

14. Abbreviations

Table 10. Abbreviations

Acronym	Description
CMOS	Complementary Metal Oxide Semiconductor
ESD	ElectroStatic Discharge
HBM	Human Body Model
MM	Machine Model
PRR	Pulse Rate Repetition
TTL	Transistor-Transistor Logic

15. Revision history

Table 11. Revision history

Document ID	Release date	Data sheet status	Change notice	Supersedes
LSF0101 v.2	20200923	Product data sheet	-	LSF0101 v.1.1
Modifications:	<ul style="list-style-type: none"> Type number LSF0101GW (SOT363/SC-88) added. 			
LSF0101 v.1.1	20200626	Product data sheet	-	LSF0101 v.1
Modifications:	<ul style="list-style-type: none"> Type number LSF0101GW (SOT363/SC-88) is in development and removed from this product data sheet. Preliminary data sheet is available upon request. 			
LSF0101 v.1	20200414	Product data sheet	-	-

16. Legal information

Data sheet status

Document status [1][2]	Product status [3]	Definition
Objective [short] data sheet	Development	This document contains data from the objective specification for product development.
Preliminary [short] data sheet	Qualification	This document contains data from the preliminary specification.
Product [short] data sheet	Production	This document contains the product specification.

- [1] Please consult the most recently issued document before initiating or completing a design.
- [2] The term 'short data sheet' is explained in section "Definitions".
- [3] The product status of device(s) described in this document may have changed since this document was published and may differ in case of multiple devices. The latest product status information is available on the internet at <https://www.nexperia.com>.

Definitions

Draft — The document is a draft version only. The content is still under internal review and subject to formal approval, which may result in modifications or additions. Nexperia does not give any representations or warranties as to the accuracy or completeness of information included herein and shall have no liability for the consequences of use of such information.

Short data sheet — A short data sheet is an extract from a full data sheet with the same product type number(s) and title. A short data sheet is intended for quick reference only and should not be relied upon to contain detailed and full information. For detailed and full information see the relevant full data sheet, which is available on request via the local Nexperia sales office. In case of any inconsistency or conflict with the short data sheet, the full data sheet shall prevail.

Product specification — The information and data provided in a Product data sheet shall define the specification of the product as agreed between Nexperia and its customer, unless Nexperia and customer have explicitly agreed otherwise in writing. In no event however, shall an agreement be valid in which the Nexperia product is deemed to offer functions and qualities beyond those described in the Product data sheet.

Disclaimers

Limited warranty and liability — Information in this document is believed to be accurate and reliable. However, Nexperia does not give any representations or warranties, expressed or implied, as to the accuracy or completeness of such information and shall have no liability for the consequences of use of such information. Nexperia takes no responsibility for the content in this document if provided by an information source outside of Nexperia.

In no event shall Nexperia be liable for any indirect, incidental, punitive, special or consequential damages (including - without limitation - lost profits, lost savings, business interruption, costs related to the removal or replacement of any products or rework charges) whether or not such damages are based on tort (including negligence), warranty, breach of contract or any other legal theory.

Notwithstanding any damages that customer might incur for any reason whatsoever, Nexperia's aggregate and cumulative liability towards customer for the products described herein shall be limited in accordance with the Terms and conditions of commercial sale of Nexperia.

Right to make changes — Nexperia reserves the right to make changes to information published in this document, including without limitation specifications and product descriptions, at any time and without notice. This document supersedes and replaces all information supplied prior to the publication hereof.

Suitability for use — Nexperia products are not designed, authorized or warranted to be suitable for use in life support, life-critical or safety-critical systems or equipment, nor in applications where failure or malfunction of an Nexperia product can reasonably be expected to result in personal

injury, death or severe property or environmental damage. Nexperia and its suppliers accept no liability for inclusion and/or use of Nexperia products in such equipment or applications and therefore such inclusion and/or use is at the customer's own risk.

Quick reference data — The Quick reference data is an extract of the product data given in the Limiting values and Characteristics sections of this document, and as such is not complete, exhaustive or legally binding.

Applications — Applications that are described herein for any of these products are for illustrative purposes only. Nexperia makes no representation or warranty that such applications will be suitable for the specified use without further testing or modification.

Customers are responsible for the design and operation of their applications and products using Nexperia products, and Nexperia accepts no liability for any assistance with applications or customer product design. It is customer's sole responsibility to determine whether the Nexperia product is suitable and fit for the customer's applications and products planned, as well as for the planned application and use of customer's third party customer(s). Customers should provide appropriate design and operating safeguards to minimize the risks associated with their applications and products.

Nexperia does not accept any liability related to any default, damage, costs or problem which is based on any weakness or default in the customer's applications or products, or the application or use by customer's third party customer(s). Customer is responsible for doing all necessary testing for the customer's applications and products using Nexperia products in order to avoid a default of the applications and the products or of the application or use by customer's third party customer(s). Nexperia does not accept any liability in this respect.

Limiting values — Stress above one or more limiting values (as defined in the Absolute Maximum Ratings System of IEC 60134) will cause permanent damage to the device. Limiting values are stress ratings only and (proper) operation of the device at these or any other conditions above those given in the Recommended operating conditions section (if present) or the Characteristics sections of this document is not warranted. Constant or repeated exposure to limiting values will permanently and irreversibly affect the quality and reliability of the device.

Terms and conditions of commercial sale — Nexperia products are sold subject to the general terms and conditions of commercial sale, as published at <http://www.nexperia.com/profile/terms>, unless otherwise agreed in a valid written individual agreement. In case an individual agreement is concluded only the terms and conditions of the respective agreement shall apply. Nexperia hereby expressly objects to applying the customer's general terms and conditions with regard to the purchase of Nexperia products by customer.

No offer to sell or license — Nothing in this document may be interpreted or construed as an offer to sell products that is open for acceptance or the grant, conveyance or implication of any license under any copyrights, patents or other industrial or intellectual property rights.

Export control — This document as well as the item(s) described herein may be subject to export control regulations. Export might require a prior authorization from competent authorities.

Non-automotive qualified products — Unless this data sheet expressly states that this specific Nexperia product is automotive qualified, the product is not suitable for automotive use. It is neither qualified nor tested in accordance with automotive testing or application requirements. Nexperia accepts no liability for inclusion and/or use of non-automotive qualified products in automotive equipment or applications.

In the event that customer uses the product for design-in and use in automotive applications to automotive specifications and standards, customer (a) shall use the product without Nexperia's warranty of the product for such automotive applications, use and specifications, and (b) whenever customer uses the product for automotive applications beyond Nexperia's specifications such use shall be solely at customer's own risk, and (c) customer fully indemnifies Nexperia for any liability, damages or failed product claims resulting from customer design and use of the product for automotive applications beyond Nexperia's standard warranty and Nexperia's product specifications.

Translations — A non-English (translated) version of a document is for reference only. The English version shall prevail in case of any discrepancy between the translated and English versions.

Trademarks

Notice: All referenced brands, product names, service names and trademarks are the property of their respective owners.

Contents

1. General description	1
2. Features and benefits	1
3. Applications	1
4. Ordering information	2
5. Marking	2
6. Functional diagram	2
7. Pinning information	2
7.1. Pinning.....	2
7.2. Pin description.....	3
8. Functional description	3
9. Limiting values	3
10. Recommended operating conditions	4
11. Static characteristics	4
12. Dynamic characteristics	5
12.1. Waveforms and test circuit.....	6
13. Package outline	8
14. Abbreviations	11
15. Revision history	11
16. Legal information	12

© Nexperia B.V. 2020. All rights reserved

For more information, please visit: <http://www.nexperia.com>
For sales office addresses, please send an email to: salesaddresses@nexperia.com
Date of release: 23 September 2020

X-ON Electronics

Largest Supplier of Electrical and Electronic Components

Click to view similar products for [Translation - Voltage Levels](#) category:

Click to view products by [Nexperia](#) manufacturer:

Other Similar products are found below :

[NLSX4373DMR2G](#) [NLSX5012MUTAG](#) [NLSX0102FCT2G](#) [NLSX4302EBMUTCG](#) [PCA9306FMUTAG](#) [MC100EPT622MNG](#)
[NLSX3014MUTAG](#) [NLSV4T244EMUTAG](#) [NLSX5011MUTCG](#) [NLV9306USG](#) [NLV SX4014MUTAG](#) [NLSV4T3144MUTAG](#)
[NLV SX4373MUTAG](#) [MAX3371ELT+T](#) [NLSX3013BFCT1G](#) [NLV7WBD3125USG](#) [NLSX3012DMR2G](#) [74AVCH1T45FZ4-7](#)
[NLVSV1T244MUTBG](#) [74AVC1T45GS-Q100H](#) [CLVC16T245MDGGREP](#) [MC10H124FNG](#) [CAVCB164245MDGGREP](#) [CD40109BPWR](#)
[MC10H350FNG](#) [MC10H125FNG](#) [MC100EPT21MNR4G](#) [MC100EP91DWG](#) [NLSV2T244MUTAG](#) [NLSX3013FCT1G](#)
[NLSX5011AMX1TCG](#) [PCA9306USG](#) [SN74AVCA406LZQSR](#) [NLSX4014DTR2G](#) [NLSX3018DTR2G](#) [LTC1045CSW#PBF](#)
[LTC1045CN#PBF](#) [SY100EL92ZG](#) [74AXP1T34GMH](#) [74AXP1T34GNH](#) [PI4ULS3V204LE](#) [ADG3245BRUZ-REEL7](#) [ADG3123BRUZ](#)
[ADG3245BRUZ](#) [ADG3246BCPZ](#) [ADG3308BCPZ-REEL](#) [ADG3233BRJZ-REEL7](#) [ADG3233BRMZ](#) [ADG3241BKSZ-500RL7](#)
[ADG3242BRJZ-REEL7](#)