

Important notice

Dear Customer,

On 7 February 2017 the former NXP Standard Product business became a new company with the tradename **Nexperia**. Nexperia is an industry leading supplier of Discrete, Logic and PowerMOS semiconductors with its focus on the automotive, industrial, computing, consumer and wearable application markets

In data sheets and application notes which still contain NXP or Philips Semiconductors references, use the references to Nexperia, as shown below.

Instead of <http://www.nxp.com>, <http://www.philips.com/> or <http://www.semiconductors.philips.com/>, use <http://www.nexperia.com>

Instead of sales.addresses@www.nxp.com or sales.addresses@www.semiconductors.philips.com, use salesaddresses@nexperia.com (email)

Replace the copyright notice at the bottom of each page or elsewhere in the document, depending on the version, as shown below:

- © NXP N.V. (year). All rights reserved or © Koninklijke Philips Electronics N.V. (year). All rights reserved

Should be replaced with:

- © **Nexperia B.V. (year). All rights reserved.**

If you have any questions related to the data sheet, please contact our nearest sales office via e-mail or telephone (details via salesaddresses@nexperia.com). Thank you for your cooperation and understanding,

Kind regards,

Team Nexperia

DATA SHEET

PDTC115E series

NPN resistor-equipped transistors;

R1 = 100 k Ω , R2 = 100 k Ω

Product data sheet
Supersedes data of 2004 Apr 06

2004 Aug 06

NPN resistor-equipped transistors; R1 = 100 k Ω , R2 = 100 k Ω

PDTC115E series

FEATURES

- Built-in bias resistors
- Simplified circuit design
- Reduction of component count
- Reduced pick and place costs.

APPLICATIONS

- General purpose switching and amplification
- Inverter and interface circuits
- Circuit driver.

QUICK REFERENCE DATA

SYMBOL	PARAMETER	TYP.	MAX.	UNIT
V _{CEO}	collector-emitter voltage	–	50	V
I _O	output current (DC)	–	20	mA
R1	bias resistor	100	–	k Ω
R2	bias resistor	100	–	k Ω

DESCRIPTION

NPN resistor equipped transistor (see “Simplified outline, symbol and pinning” for package details).

PRODUCT OVERVIEW

TYPE NUMBER	PACKAGE		MARKING CODE	PNP COMPLEMENT
	PHILIPS	EIAJ		
PDTC115EE	SOT416	SC-75	46	PDTA115EE
PDTC115EEF	SOT490	SC-89	49	PDTA115EEF
PDTC115EK	SOT346	SC-59	56	PDTA115EK
PDTC115EM	SOT883	SC-101	DV	PDTA115EM
PDTC115ES	SOT54 (TO-92)	SC-43	TC115E	PDTA115ES
PDTC115ET	SOT23	–	*44 ⁽¹⁾	PDTA115ET
PDTC115EU	SOT323	SC-70	*15 ⁽¹⁾	PDTA115EU

Note

- * = p: Made in Hong Kong.
* = t: Made in Malaysia.
* = W: Made in China.

NPN resistor-equipped transistors;
 R1 = 100 kΩ, R2 = 100 kΩ

PDTC115E series

SIMPLIFIED OUTLINE, SYMBOL AND PINNING

TYPE NUMBER	SIMPLIFIED OUTLINE AND SYMBOL	PINNING	
		PIN	DESCRIPTION
PDTC115ES		1 2 3	base collector emitter
PDTC115EE PDTC115EEF PDTC115EK PDTC115ET PDTC115EU		1 2 3	base emitter collector
PDTC115EM		1 2 3	base emitter collector

NPN resistor-equipped transistors;
R1 = 100 k Ω , R2 = 100 k Ω

PDTC115E series

ORDERING INFORMATION

TYPE NUMBER	PACKAGE		
	NAME	DESCRIPTION	VERSION
PDTC115EE	–	plastic surface mounted package; 3 leads	SOT416
PDTC115EEF	–	plastic surface mounted package; 3 leads	SOT490
PDTC115EK	–	plastic surface mounted package; 3 leads	SOT346
PDTC115EM	–	leadless ultra small plastic package; 3 solder lands; body 1.0 × 0.6 × 0.5 mm	SOT883
PDTC115ES	–	plastic single-ended leaded (through hole) package; 3 leads	SOT54
PDTC115ET	–	plastic surface mounted package; 3 leads	SOT23
PDTC115EU	–	plastic surface mounted package; 3 leads	SOT323

LIMITING VALUES

In accordance with the Absolute Maximum Rating System (IEC 60134).

SYMBOL	PARAMETER	CONDITIONS	MIN.	MAX.	UNIT
V _{CB0}	collector-base voltage	open emitter	–	50	V
V _{CE0}	collector-emitter voltage	open base	–	50	V
V _{EB0}	emitter-base voltage	open collector	–	10	V
V _I	input voltage positive negative		–	+40	V
			–	–10	V
I _O	output current (DC)		–	20	mA
I _{CM}	peak collector current		–	100	mA
P _{tot}	total power dissipation SOT54 SOT23 SOT346 SOT323 SOT416 SOT883 SOT490	T _{amb} ≤ 25 °C			
		note 1	–	500	mW
		note 1	–	250	mW
		note 1	–	250	mW
		note 1	–	200	mW
		note 1	–	150	mW
		notes 2 and 3	–	250	mW
notes 1 and 2	–	250	mW		
T _{stg}	storage temperature		–65	+150	°C
T _j	junction temperature		–	150	°C
T _{amb}	operating ambient temperature		–65	+150	°C

Notes

1. Refer to standard mounting conditions.
2. Reflow soldering is the only recommended soldering method.
3. Refer to SOT883 standard mounting conditions; FR4 with 60 μ m copper strip line.

NPN resistor-equipped transistors;
R1 = 100 k Ω , R2 = 100 k Ω

PDTC115E series

THERMAL CHARACTERISTICS

SYMBOL	PARAMETER	CONDITIONS	VALUE	UNIT
R _{th(j-a)}	thermal resistance from junction to ambient	in free air		
	SOT54	note 1	250	K/W
	SOT23	note 1	500	K/W
	SOT346	note 1	500	K/W
	SOT323	note 1	625	K/W
	SOT416	note 1	833	K/W
	SOT833	notes 2 and 3	500	K/W
	SOT490	notes 1 and 2	500	K/W

Notes

1. Refer to standard mounting conditions.
2. Reflow soldering is the only recommended soldering method.
3. Refer to SOT883 standard mounting conditions; FR4 with 60 μ m copper strip line.

CHARACTERISTICS

T_{amb} = 25 °C unless otherwise specified.

SYMBOL	PARAMETER	CONDITIONS	MIN.	TYP.	MAX.	UNIT
I _{CBO}	collector-base cut-off current	V _{CB} = 50 V; I _E = 0 A	–	–	100	nA
I _{CEO}	collector-emitter cut-off current	V _{CE} = 30 V; I _B = 0 A	–	–	1	μ A
		V _{CE} = 30 V; I _B = 0 A; T _j = 150 °C	–	–	50	μ A
I _{EBO}	emitter-base cut-off current	V _{EB} = 5 V; I _C = 0 A	–	–	50	μ A
h _{FE}	DC current gain	V _{CE} = 5 V; I _C = 5 mA	80	–	–	
V _{CEsat}	collector-emitter saturation voltage	I _C = 5 mA; I _B = 0.25 mA	–	–	150	mV
V _{i(off)}	input-off voltage	I _C = 100 μ A; V _{CE} = 5 V	–	1.1	0.5	V
V _{i(on)}	input-on voltage	I _C = 1 mA; V _{CE} = 0.3 V	3	1.5	–	V
R1	input resistor		70	100	130	k Ω
$\frac{R2}{R1}$	resistor ratio		0.8	1	1.2	
C _c	collector capacitance	I _E = i _e = 0 A; V _{CB} = 10 V; f = 1 MHz	–	–	2.5	pF

NPN resistor-equipped transistors;
R1 = 100 kΩ, R2 = 100 kΩ

PDTC115E series

PACKAGE OUTLINES

Plastic surface-mounted package; 3 leads

SOT416

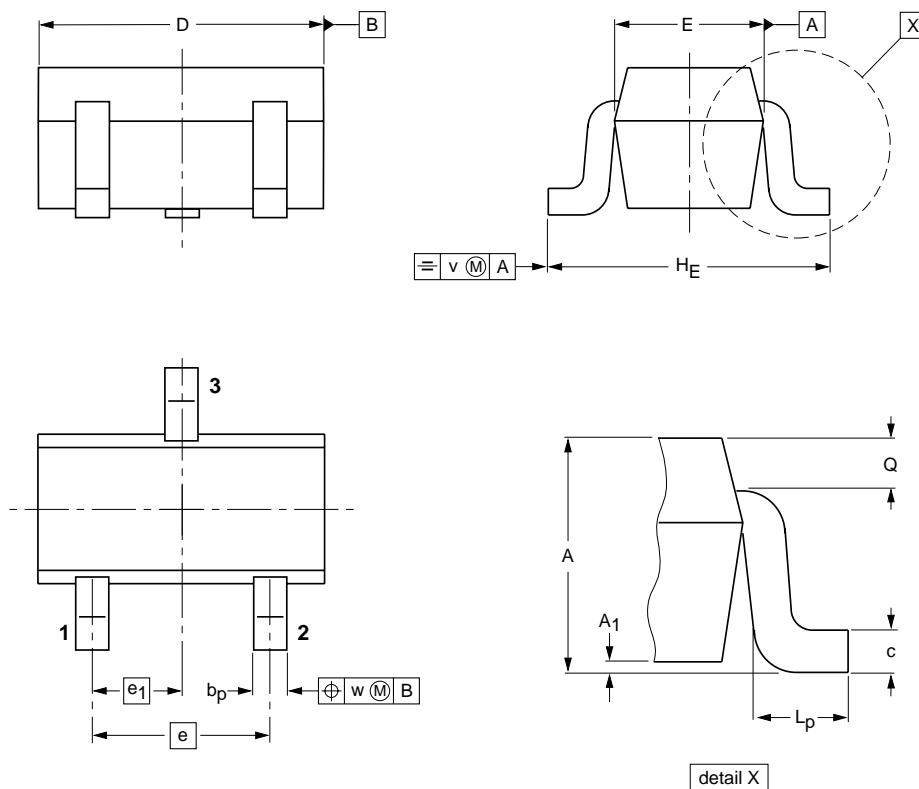

DIMENSIONS (mm are the original dimensions)

UNIT	A	A ₁ max	b _p	c	D	E	e	e ₁	H _E	L _p	Q	v	w
mm	0.95 0.60	0.1	0.30 0.15	0.25 0.10	1.8 1.4	0.9 0.7	1	0.5	1.75 1.45	0.45 0.15	0.23 0.13	0.2	0.2

OUTLINE VERSION	REFERENCES			EUROPEAN PROJECTION	ISSUE DATE
	IEC	JEDEC	JEITA		
SOT416			SC-75		04-11-04 06-03-16

NPN resistor-equipped transistors;
R1 = 100 kΩ, R2 = 100 kΩ

PDTC115E series

Plastic surface-mounted package; 3 leads

SOT346

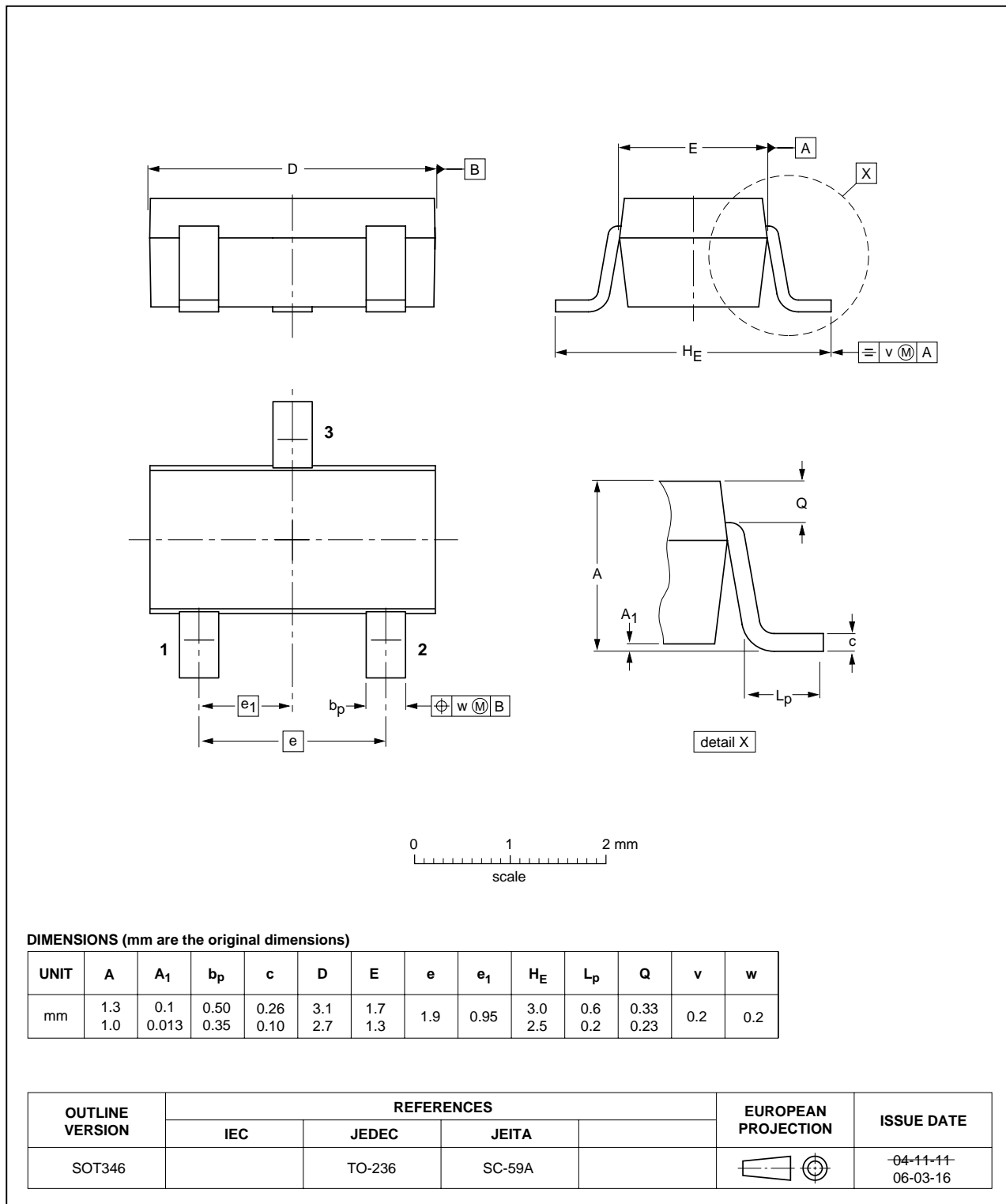

NPN resistor-equipped transistors;
R1 = 100 kΩ, R2 = 100 kΩ

PDTC115E series

Leadless ultra small plastic package; 3 solder lands; body 1.0 x 0.6 x 0.5 mm

SOT883

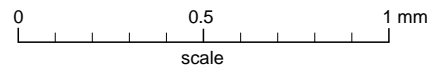
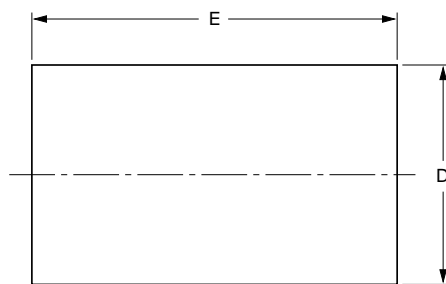
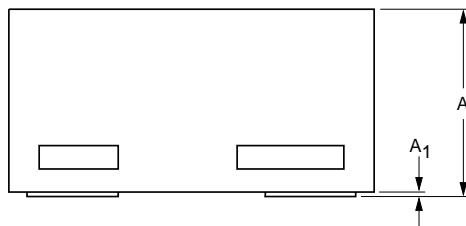

DIMENSIONS (mm are the original dimensions)

UNIT	A ⁽¹⁾	A ₁ max.	b	b ₁	D	E	e	e ₁	L	L ₁
mm	0.50 0.46	0.03	0.20 0.12	0.55 0.47	0.62 0.55	1.02 0.95	0.35	0.65	0.30 0.22	0.30 0.22

Note

1. Including plating thickness

OUTLINE VERSION	REFERENCES			EUROPEAN PROJECTION	ISSUE DATE
	IEC	JEDEC	JEITA		
SOT883			SC-101		03-02-05 03-04-03

NPN resistor-equipped transistors;
R1 = 100 kΩ, R2 = 100 kΩ

PDTC115E series

Plastic single-ended leaded (through hole) package; 3 leads

SOT54

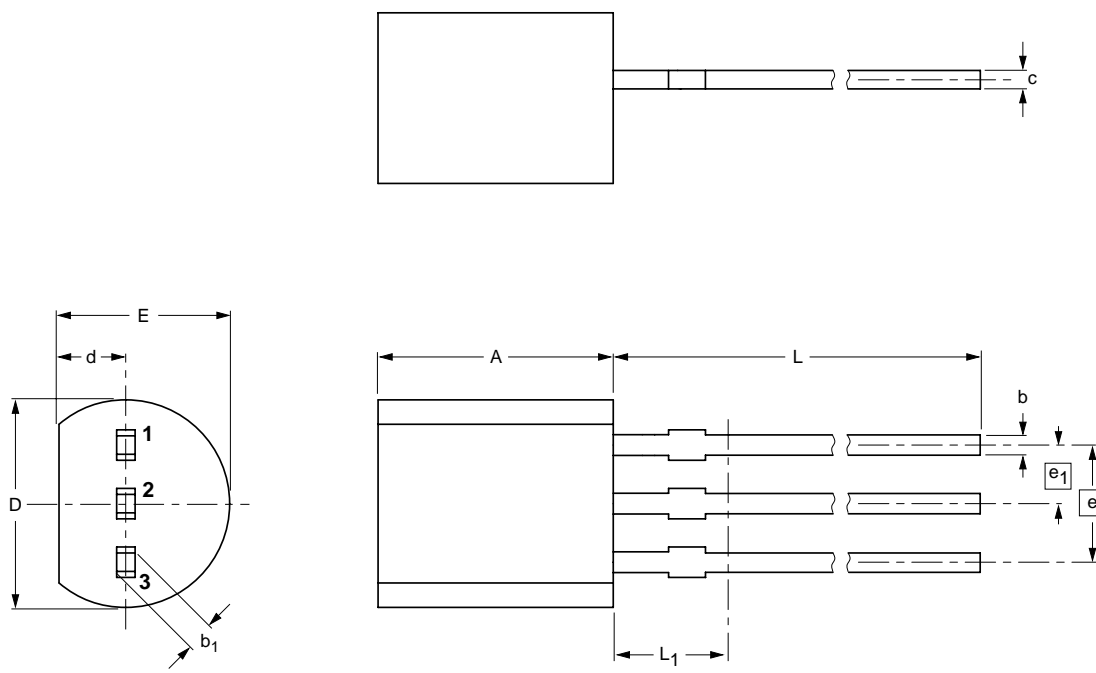

DIMENSIONS (mm are the original dimensions)

UNIT	A	b	b ₁	c	D	d	E	e	e ₁	L	L ₁ ⁽¹⁾ max.
mm	5.2 5.0	0.48 0.40	0.66 0.55	0.45 0.38	4.8 4.4	1.7 1.4	4.2 3.6	2.54	1.27	14.5 12.7	2.5

Note

1. Terminal dimensions within this zone are uncontrolled to allow for flow of plastic and terminal irregularities.

OUTLINE VERSION	REFERENCES			EUROPEAN PROJECTION	ISSUE DATE
	IEC	JEDEC	JEITA		
SOT54		TO-92	SC-43A		04-06-28 04-11-16

NPN resistor-equipped transistors;
R1 = 100 kΩ, R2 = 100 kΩ

PDTC115E series

Plastic surface-mounted package; 3 leads

SOT23



DIMENSIONS (mm are the original dimensions)

UNIT	A	A ₁ max.	b _p	c	D	E	e	e ₁	H _E	L _p	Q	v	w
mm	1.1 0.9	0.1	0.48 0.38	0.15 0.09	3.0 2.8	1.4 1.2	1.9	0.95	2.5 2.1	0.45 0.15	0.55 0.45	0.2	0.1

OUTLINE VERSION	REFERENCES				EUROPEAN PROJECTION	ISSUE DATE
	IEC	JEDEC	JEITA			
SOT23		TO-236AB				04-11-04 06-03-16

NPN resistor-equipped transistors;
R1 = 100 kΩ, R2 = 100 kΩ

PDTC115E series

Plastic surface-mounted package; 3 leads

SOT323



DIMENSIONS (mm are the original dimensions)

UNIT	A	A ₁ max	b _p	c	D	E	e	e ₁	H _E	L _p	Q	v	w
mm	1.1 0.8	0.1	0.4 0.3	0.25 0.10	2.2 1.8	1.35 1.15	1.3	0.65	2.2 2.0	0.45 0.15	0.23 0.13	0.2	0.2

OUTLINE VERSION	REFERENCES				EUROPEAN PROJECTION	ISSUE DATE
	IEC	JEDEC	JEITA			
SOT323			SC-70			04-11-04 06-03-16

NPN resistor-equipped transistors;
R1 = 100 kΩ, R2 = 100 kΩ

PDTC115E series

Plastic surface-mounted package; 3 leads

SOT490

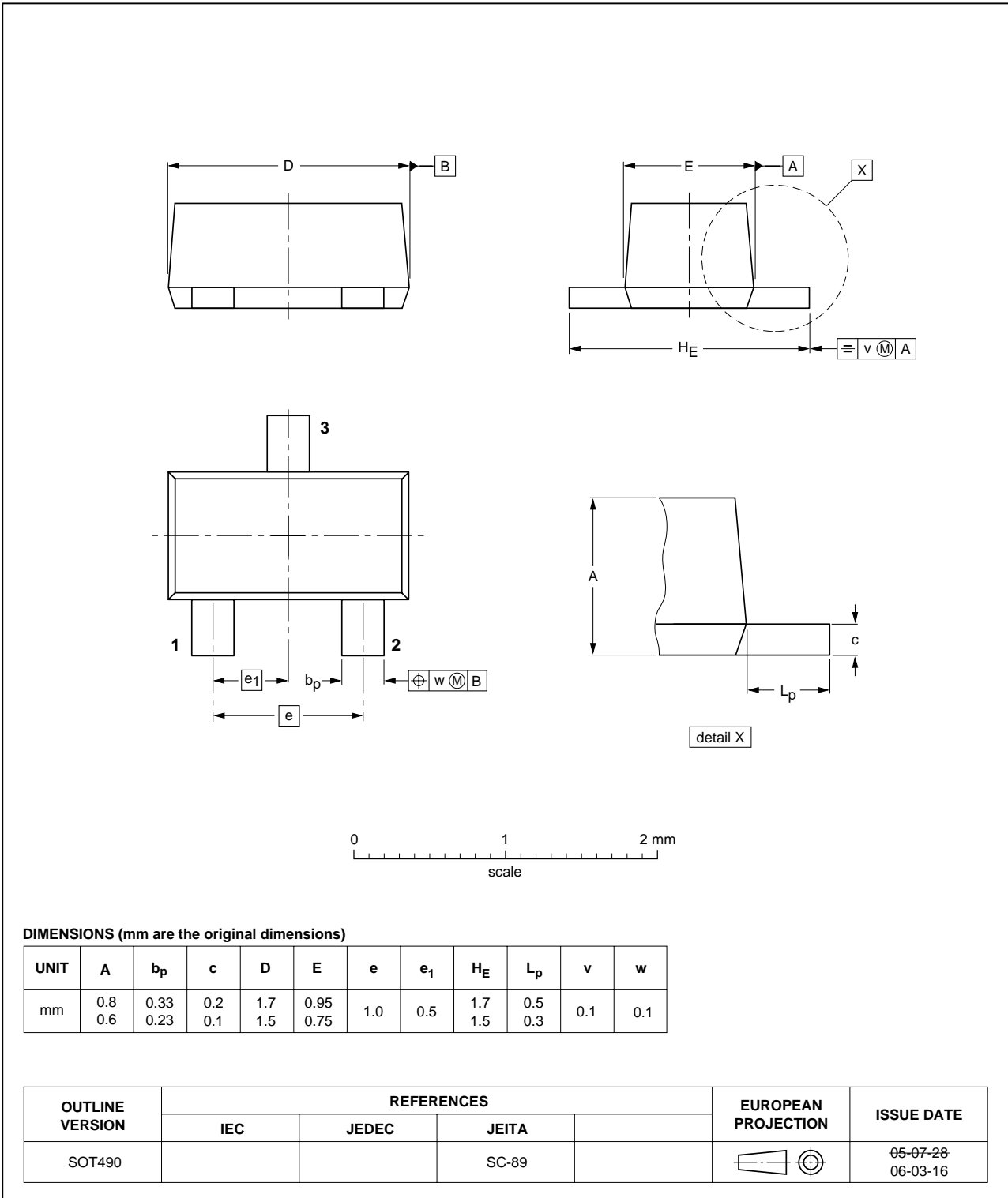

NPN resistor-equipped transistors;
R1 = 100 kΩ, R2 = 100 kΩ

PDTC115E series

DATA SHEET STATUS

DOCUMENT STATUS⁽¹⁾	PRODUCT STATUS⁽²⁾	DEFINITION
Objective data sheet	Development	This document contains data from the objective specification for product development.
Preliminary data sheet	Qualification	This document contains data from the preliminary specification.
Product data sheet	Production	This document contains the product specification.

Notes

1. Please consult the most recently issued document before initiating or completing a design.
2. The product status of device(s) described in this document may have changed since this document was published and may differ in case of multiple devices. The latest product status information is available on the Internet at URL <http://www.nxp.com>.

DISCLAIMERS

General — Information in this document is believed to be accurate and reliable. However, NXP Semiconductors does not give any representations or warranties, expressed or implied, as to the accuracy or completeness of such information and shall have no liability for the consequences of use of such information.

Right to make changes — NXP Semiconductors reserves the right to make changes to information published in this document, including without limitation specifications and product descriptions, at any time and without notice. This document supersedes and replaces all information supplied prior to the publication hereof.

Suitability for use — NXP Semiconductors products are not designed, authorized or warranted to be suitable for use in medical, military, aircraft, space or life support equipment, nor in applications where failure or malfunction of an NXP Semiconductors product can reasonably be expected to result in personal injury, death or severe property or environmental damage. NXP Semiconductors accepts no liability for inclusion and/or use of NXP Semiconductors products in such equipment or applications and therefore such inclusion and/or use is at the customer's own risk.

Applications — Applications that are described herein for any of these products are for illustrative purposes only. NXP Semiconductors makes no representation or warranty that such applications will be suitable for the specified use without further testing or modification.

Limiting values — Stress above one or more limiting values (as defined in the Absolute Maximum Ratings System of IEC 60134) may cause permanent damage to the device. Limiting values are stress ratings only and operation of the device at these or any other conditions

above those given in the Characteristics sections of this document is not implied. Exposure to limiting values for extended periods may affect device reliability.

Terms and conditions of sale — NXP Semiconductors products are sold subject to the general terms and conditions of commercial sale, as published at <http://www.nxp.com/profile/terms>, including those pertaining to warranty, intellectual property rights infringement and limitation of liability, unless explicitly otherwise agreed to in writing by NXP Semiconductors. In case of any inconsistency or conflict between information in this document and such terms and conditions, the latter will prevail.

No offer to sell or license — Nothing in this document may be interpreted or construed as an offer to sell products that is open for acceptance or the grant, conveyance or implication of any license under any copyrights, patents or other industrial or intellectual property rights.

Export control — This document as well as the item(s) described herein may be subject to export control regulations. Export might require a prior authorization from national authorities.

Quick reference data — The Quick reference data is an extract of the product data given in the Limiting values and Characteristics sections of this document, and as such is not complete, exhaustive or legally binding.

NXP Semiconductors

Customer notification

This data sheet was changed to reflect the new company name NXP Semiconductors, including new legal definitions and disclaimers. No changes were made to the technical content, except for package outline drawings which were updated to the latest version.

Contact information

For additional information please visit: <http://www.nxp.com>

For sales offices addresses send e-mail to: salesaddresses@nxp.com

© NXP B.V. 2009

All rights are reserved. Reproduction in whole or in part is prohibited without the prior written consent of the copyright owner.

The information presented in this document does not form part of any quotation or contract, is believed to be accurate and reliable and may be changed without notice. No liability will be accepted by the publisher for any consequence of its use. Publication thereof does not convey nor imply any license under patent- or other industrial or intellectual property rights.

Printed in The Netherlands

R75/05/pp14

Date of release: 2004 Aug 06

Document order number: 9397 750 13666



X-ON Electronics

Largest Supplier of Electrical and Electronic Components

Click to view similar products for [Bipolar Transistors - Pre-Biased](#) category:

Click to view products by [Nexperia](#) manufacturer:

Other Similar products are found below :

[RN1607\(TE85L,F\)](#) [DRC9A14E0L](#) [DTA124GKAT146](#) [DTA144WETL](#) [DTA144WKAT146](#) [DTC113EET1G](#) [DTC115TETL](#)
[DTC115TKAT146](#) [DTC124TETL](#) [DTC144VUAT106](#) [MUN5241T1G](#) [BCR158WH6327XTSA1](#) [NSBA114TDP6T5G](#) [NSBA123EF3T5G](#)
[NSBA143TF3T5G](#) [NSBA144TF3T5G](#) [NSBC113EF3T5G](#) [NSBC124XF3T5G](#) [SMUN5330DW1T1G](#) [SSVMUN5312DW1T2G](#)
[RN1303\(TE85L,F\)](#) [RN1306\(TE85L,F\)](#) [RN4605\(TE85L,F\)](#) [TTEPROTOTYPE79](#) [UMC3NTR](#) [EMH15T2R](#) [SMUN2214T3G](#)
[SMUN5113DW1T1G](#) [SMUN5335DW1T1G](#) [NSBA124XF3T5G](#) [NSBC123EF3T5G](#) [NSBC143ZPDP6T5G](#) [NSBC144TF3T5G](#)
[NSVMUN5113DW1T3G](#) [SMUN5230DW1T1G](#) [SMUN2214T1G](#) [FMA7AT148](#) [DTC123TKAT146](#) [DTC114EUA-TP](#) [NSVDTA114EET1G](#)
[SMUN5237DW1T1G](#) [SMUN5213DW1T1G](#) [SMUN5114DW1T1G](#) [SMUN2111T1G](#) [DTC124ECA-TP](#) [DTC123TM3T5G](#) [DTA114ECA-TP](#)
[DTA113EM3T5G](#) [DTC113EM3T5G](#) [NSVMUN5135DW1T1G](#)