



CIRP SERIES (MIL-C-5015 STYLE)

Modular Bayonet Lock Connector



CIRP

MODULAR BAYONET LOCK CONNECTOR

The CIR (Connector for Industrial Range) series is derived from the American Mil-C-5015 & VG95234 specifications and is approved to the French rail specification NF F 61 030.

The connectors are intermateable and interchangeable with corresponding types, but feature a low fire hazard thermoplastic insulator which is removable for repositioning at an alternative orientation.

Contacts are retained in the insulator by means of a unique beryllium copper spring clip.

Connector sealing features a stepped wire seal grommet which removes the need to populate unused cavities with filler plugs.

Crimp tooling is industry standard and contacts are inserted and removed using simple hand tools.

Benefits include:

- CIRP connectors qualified to NF F 61 030 norm.
- Approved for use on railway equipment by SNCF, RATP, Alstom Transport, Bombardier and LUL.
- Compatible with existing MS 5015 reverse bayonet types.
- Low fire hazard/low halogen insulator material tested to French NF F 16-101 norm and BS 6853.
- Cadmium free surface plating. Black Zinc Cobalt – Not RoHS Compliant; Silver Zinc Cobalt – RoHS Compliant.
- Removable insulator.
- Positive location of insulator shell.
- Pin insulators feature with or without bonded resilient rubber face seal.
- Rear individual wire seal grommet with webbed holes.
- Mated connector assemblies sealed to IP67.
- Part populated insulators achieve sealing without the fitting of grommet fillers.
- Contacts retained by high performance metal spring clip.
- Comprehensive range of screened/unscreened, sealed/unsealed backshells & accessories.
- 3D Models available to download from our website.

Tested to and meets the specifications of the Fire Barrier Testing: EN1363. BS476



Technical Information 3-4

Part Number Explanation 5

Basic Assembly 6

Shell Assemblies 7

Insulators 8

Individual Wire Seal Grommet 9

Crimp Contacts 10-11

Insert Arrangements 12

Insert Arrangement Selector 13

Insulator Orientations 14

Additional Alignment/Polarising Device 15

Rear Panel Mounted Receptacle 16

Front Panel Mounted Receptacle 17

Plug Connector (style 'T' less accessories) 18

Single Hole Mounting 19

Plug Connector with Protective Rubber Ring (style 'T' less accessories) 20

Locking Backnut for Grommet Sealing only - LBN 21

Straight Conduit Heatshrink Screen Adaptor - SCHSA (locking) 22

90° Elbow Conduit Heatshrink Screen Adaptor - ECHSA (locking) 23

Shell Heatshrink Extender - SHE (PG/METRIC inner thread - imperial outer thread) (locking) 24

Step-Up Adapters - SUA (PG/METRIC inner thread - Imperial outer thread) (locking) 25

Step-Down Adapters - SDA (PG/METRIC inner thread - Imperial outer thread) 26

Cable Gland Adapters (fitting on SCHSA & ECHSA accessory with PG/METRIC thread) 27

Shell Extender with Screening - SPTAS (non locking) 28

Adapters - CRA (2 piece adaptor to terminate cable screen braid to connector with conduit outer) 29

Waterproof Clamp for Jacketed Cable - CIRMSP3057C 30

Cable Clamp - CIRMSP3057A 31

Telescopic Bushing - SBMSH554 (use with CIRMSP3057A clamp) 32

Panel Gasket, Non-Conductive/Conductive Front & Rear Mounted Connectors - RPG/S & FPG/S 33

Connector Fixing Nut Plates 34

Receptacle Mounting Detail 35

Metal Protective Caps 36

RFI Braid Sock, Bandit Strap & Knitmesh Braid 37

Tooling for crimp contacts 38

Notes 39

Notes 40

Notes 41

Please note all images are for reference only.

Materials

Shell:	Aluminium Alloy
Insulator:	Low fire hazard thermoplastic qualified to NFF 16101 and to meet BS 6853
Grommet & bushing:	Low fire hazard rubber tested to NFF 16101 norm and to meet BS 6853
Contacts:	Copper alloy
Contact retaining clip:	Beryllium copper
Accessory hardware:	Aluminium alloy

Standard Plating Finishes

Aluminium parts:	Black chromate over zinc cobalt and silver passivate RoHS compliant
Contacts:	Gold over silver (#16 gold only)

* Consult TE for alternative finishes

Environmental Ratings

Operating temperature range:	-55 °C to +125 °C
Shock severity:	75g
Vibration:	5-500Hz long endurance. 30 hours at 10g
Acceleration:	50g

Mechanical Features

Coupling:	3 pin reverse bayonet. 120° coupling nut rotation
Number of contacts:	7 to 60
Contact termination:	Crimp & PCB
Minimum retention force of the contact in the insulator:	Beryllium copper spring clip 70N for contacts #16 (1.6 mm) 90N for contacts #12 (2.4 mm) 110N for contacts #8 (3.6 mm)
Sealing:	IP67 rated when connectors are mated and used with appropriate sealed backshell
Matings:	2000 minimum mating and unmating
Max Coupling Torque:	8NM

CIRPO3 receptacle connectors feature stainless steel pins at critical wear points of the cam tracks. This feature is incorporated to protect against excessive wear inflicted by continuous mating/de-mating and heavy vibration.

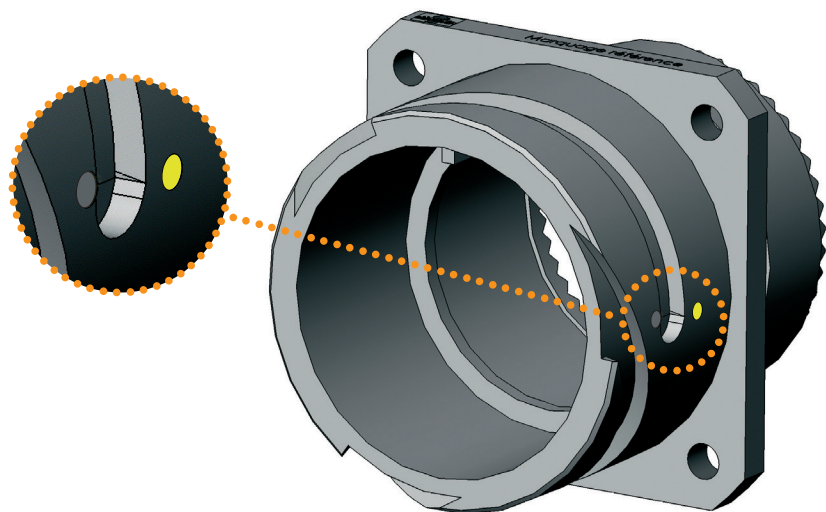

Contact Size AWG	*Maximum Current @ 20 °C	* Rated Current @ 85 °C	** De-rated Current @ 85 °C
16	22A	13A	10A
12	41A	23A	20A
8	73A	46A	42A

* Single contact in isolation
 ** Grouped contacts

Contact Arrangement Service Rating

Service Rating	Sea Level	
	A	D
Working voltage DC or AC Peak	700 V	1,250 V
Voltage Proof AC RMS	2,000 V	2,800 V
Minimum Flashover AC RMS	2,800 V	3,600 V

Contact Current De-rating

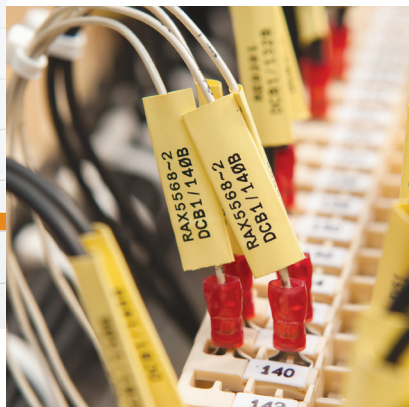
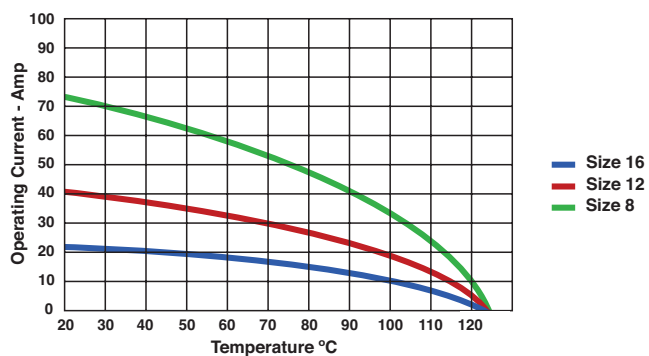

PART NUMBER EXPLANATION

CIRP	03	LBN	22	14	GPS	P	FS	****	**	*
Series Prefix		Accessory Type		Contact Arrangement		Contact Type P=Pin S=Socket		Modification Code		Insulator Orientation
	Shell Style		Shell Size		Grommet Type		Face Seal		Contact Supply	

Series Prefix:	CIRP	
Shell Style:	00	4 Hole Square flange receptacle, front panel mounted.
	03	4 Hole Square flange receptacle, rear panel mounted.
	SE06	Plug with RFI grounding
	09	Single hole mounted receptacle
	PSE06T	Plug with RFI grounding and rubber covered coupling nut
Accessory Type:	A	No rear threads and no accommodation for accessories Shell styles 00 & 03
	T	Rear threads for accessory accommodation
	LBN	Locking Back Nut
	SCHSA	Straight Conduit Heatshrink Adaptor
	ECHSA	90°Conduit Heatshrink Adaptor
	SHE#	Shell Extender M - Metric thread P - PG thread
	SUA#	Step up adapter M - Metric thread P - PG thread
	SDA#	Step down adapter M - Metric thread P - PG thread
Shell Size:	18 - 40	
Contact Arrangement:	See page 12	
Grommet Type:	As there is a choice of Wire Seal Grommet to suit varying cable diameters, this component may be omitted from the part number and ordered as a separate item if required.	
Contact Type:	P = Pin S = Socket	
Face Seal:	Pin insulator only. When face seal is required, add 'FS' to part number.	
Modification Code:	Issued for connector with non-standard feature. Consult TE for detail.	
Contact Supply:	Leave blank for connectors supplied with silver contacts Add 'P3' for gold contacts. Add 'VO' for connectors supplied without contacts.	
Insulator Orientation:	Leave blank for connectors supplied in sub-assembly form. Add applicable orientation letter (see page 14) if connectors are to be supplied factory assembled.	

Rear Panel Mounted Connector Basic Assembly

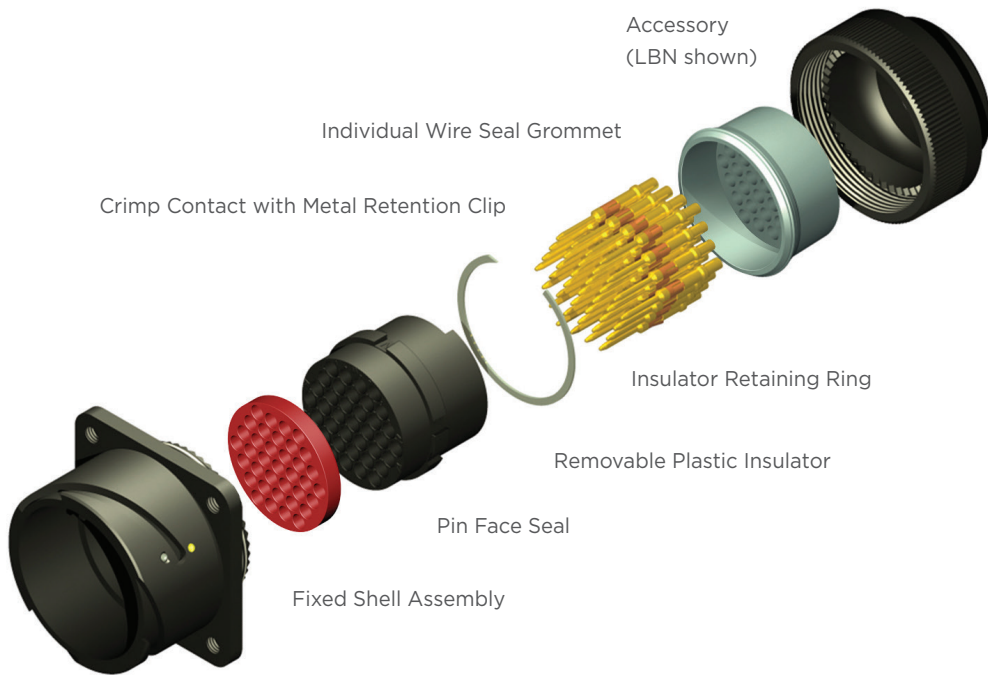

Plug Connector Basic Assembly

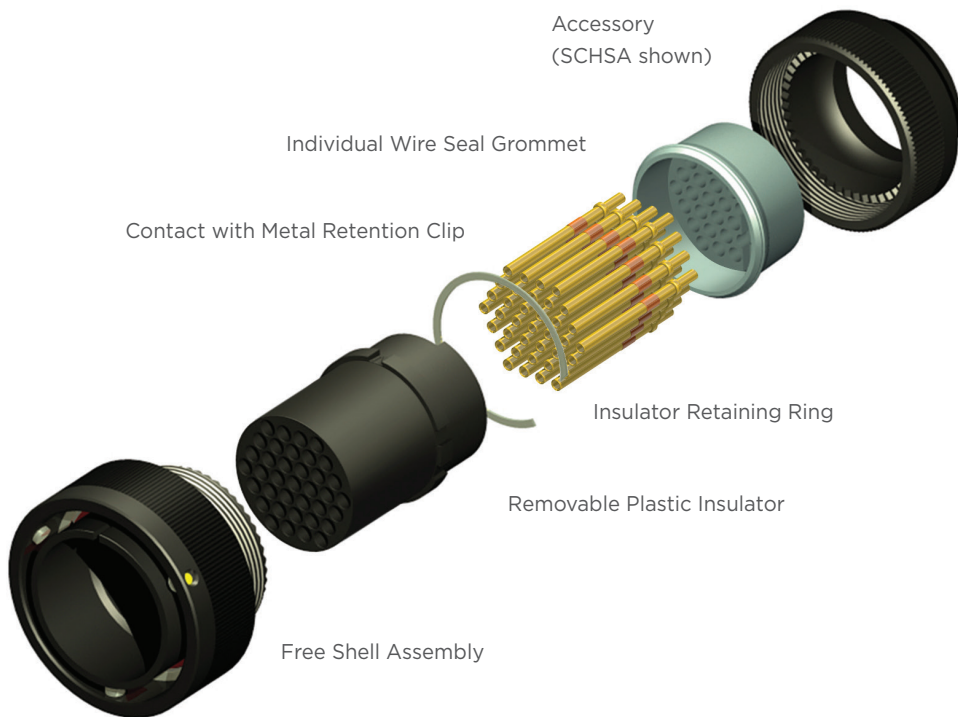

Front or Rear Mounting Fixed Receptacle



Shell Size	Part Number Rear Mount	Part Number Front Mount
18	CIRP18XR	CIRP18XF
20	CIRP20XR	CIRP20XF
22	CIRP22XR	CIRP22XF
24	CIRP24XR	CIRP24XF
28	CIRP28XR	CIRP28XF
32	CIRP32XR	CIRP32XF
36	CIRP36XR	CIRP36XF
40	CIRP40XR	CIRP40XF

Free Plug Assembly with EMI/RFI Grounding



Shell Size	Part Number
18	CIRPSE18FS
20	CIRPSE20FS
22	CIRPSE22FS
24	CIRPSE24FS
28	CIRPSE28FS
32	CIRPSE32FS
36	CIRPSE36FS
40	CIRPSE40FS

Note: Both the fixed and free shell assembly is supplied with an insulator retaining circlip.

Pin Insulator with Face Seal

Delete 'FS' if seal is not required

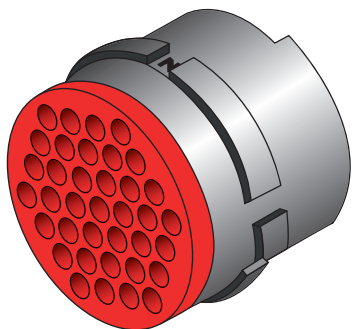

Shell Size	Contact Arrangement	Part Number
18	18-19	CIRP18-19PFS
20	20-15	CIRP20-15PFS
22	22-14	CIRP22-14PFS
24	24-10	CIRP24-10PFS
28	28-21	CIRP28-21PFS
32	32-A13	CIRP32-A13PFS
36	36-A22	CIRP36-A22PFS
40	40-A35	CIRP40-A35PFS
40	40-A60	CIRP40-A60PFS

Socket Insulator

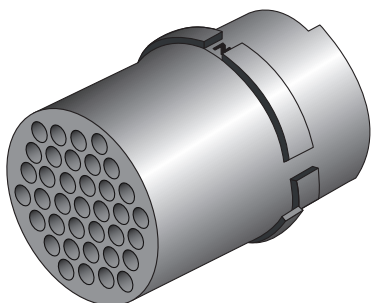

Shell Size	Contact Arrangement	Part Number
18	18-19	CIRP18-19S
20	20-15	CIRP20-15S
22	22-14	CIRP22-14S
24	24-10	CIRP24-10S
28	28-21	CIRP28-21S
32	32-A13	CIRP32-A13S
36	36-A22	CIRP36-A22S
40	40-A35	CIRP40-A35S
40	40-A60	CIRP40-A60S

Insulator Retaining Ring

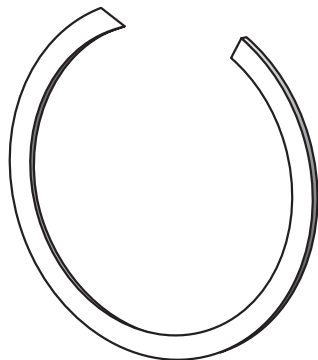

Shell Size	Part Number
18	CIRP18IC
20	CIRP20IC
22	CIRP22IC
24	CIRP24IC
28	CIRP28IC
32	CIRP32IC
36	CIRP36IC
40	CIRP40IC

Individual Wire Seal Grommets - Size 16 Contacts

Grommet Type	Contact Arrangement	Wire Insulation Min O/D mm	Wire Insulation Max O/D mm	Part Number
Pin, Small Bore	18-19	0.8	2.30	CIRP18-19GPS
	22-14			CIRP22-14GPS
	28-21			CIRP28-21GPS
	40-A60			CIRP40-A60GPS
Socket, Small Bore	18-19	0.8	2.30	CIRP18-19GSS
	22-14			CIRP22-14GSS
	28-21			CIRP28-21GSS
	40-A60			CIRP40-A60GSS
Pin, Large Bore	18-19	1.5	3.30	CIRP18-19GPL
	22-14			CIRP22-14GPL
	29-21			CIRP28-21GPL
	40-A60			CIRP40-A60GPL
Socket, Large Bore	18-19	1.5	3.30	CIRP18-19GSL
	22-14			CIRP22-14GSL
	28-21			CIRP28-21GSL
	40-A60			CIRP40-A60GSL

Individual Wire Seal Grommets - Size 12 Contacts

Grommet Type	Contact Arrangement	Wire Insulation Min O/D mm	Wire Insulation Max O/D mm	Part Number
Pin, Small Bore	20-15	0.8	2.30	CIRP20-15GPS
	32-A13			CIRP32-A13GPS
	36-A22			CIRP36-A22GPS
	40-A35			CIRP40-A35GPS
Socket, Small Bore	20-15	0.8	2.30	CIRP20-15GSS
	32-A13			CIRP32-A13GSS
	36-A22			CIRP36-A22GSS
	40-A35			CIRP40-A35GSS
Pin, Large Bore	20-15	2.35	5.20	CIRP20-15GPL
	32-A13			CIRP32-A13GPL
	36-A22			CIRP36-A22GPL
	40-A35			CIRP40-A35GPL
Socket, Large Bore	20-15	2.35	5.20	CIRP20-15GSL
	32-A13			CIRP32-A13GSL
	36-A22			CIRP36-A22GSL
	40-A35			CIRP40-A35GSL

Individual Wire Seal Grommets - Size 8 Contacts

Grommet Type	Contact Arrangement	Wire Insulation Min O/D mm	Wire Insulation Max O/D mm	Part Number
Pin, Small Bore	24-10	1.86	4.90	CIRP24-10GPS
Socket, Small Bore				CIRP24-10GSS
Pin, Large Bore		3.00	7.20	CIRP24-10GPL
Socket, Large Bore				CIRP24-10GSL

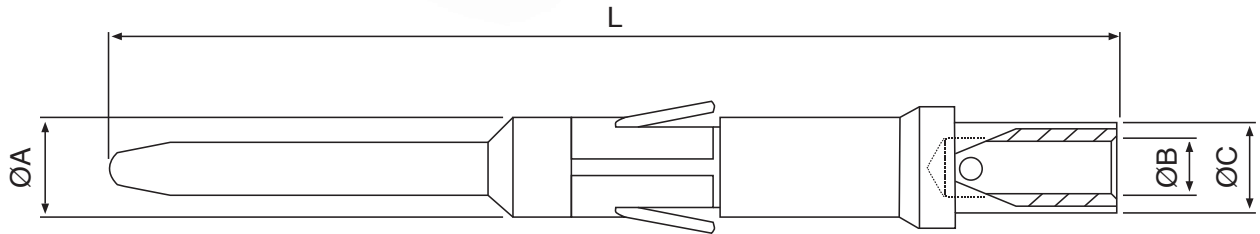

Pin

Contact Size AWG	Part Number	A	B	C	Conductor CSA mm ²	L
CIRP**/**KPKP3						
16/22	16/22	3.20	0.90	2.30	0.25/0.34	31.75
16/20	16/20		1.10	2.65	0.50/0.60	
16/18	16/18		1.25	2.30	0.75/0.93	
16	16		1.75	2.75	0.93/1.50	
16/14	16/14		1.80	2.90	1.68	
CIRP**/**KPK						
12/20	12/20	4.80	1.10	2.65	0.50/0.60	37.50
12/18	12/18		1.25	2.30	0.75/0.93	
12/16	12/16		1.75	2.75	0.93/1.50	
12/14	12/14		1.80	2.90	1.68	
12	12		2.50	3.80	2.50/3.00	
12/10	12/10		3.00	4.00	5.53	
12/(40)	12/40		2.70	4.00	4.00	
CIRBP**/**KPKP80						
8/16	8/16	7.80	1.75	2.75	0.93/1.50	40.70
8/(40)	8/40		2.90	5.20	4.00	
8/12	8/12		2.50	3.80	2.50	
8	8		4.55	6.80	9.00	
(100)	100		4.40	7.00	10.00	
(100/60)	100/60		3.40	5.50	6.00	

() = metric

Note: Size 16 contacts – gold plating only. Size 12, 8 & 100, silver or gold plating. For gold, add 'P3' to part number.

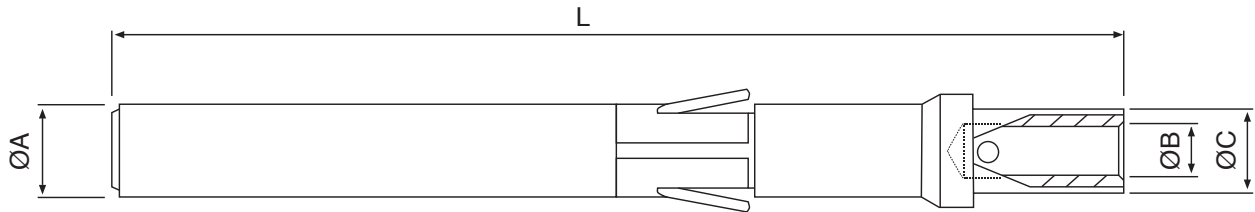

Socket

Contact Size AWG	Part Number	A	B	C	Conductor CSA mm ²	L
CIRP**/**KLKP3						
16/22	16/22	3.20	0.90	2.30	0.25/0.34	36.50
16/20	16/20		1.10	2.65	0.50/0.60	
16/18	16/18		1.25	2.30	0.75/0.93	
16	16		1.75	2.75	0.93/1.50	
16/14	16/14		1.80	2.90	1.68	
CIRP**/**KLK						
12/20	12/20	4.80	1.10	2.65	0.50/0.60	37.50
12/18	12/18		1.25	2.30	0.75/0.93	
12/16	12/16		1.75	2.75	0.93/1.50	
12/14	12/14		1.80	2.90	1.68	
12	12		2.50	3.80	2.50/3.00	
12/10	12/10		3.00	4.00	5.53	
12/(40)	12/40		2.70	4.00	4.00	
CIRBP**/**KSKP80						
8/16	8/16	7.80	1.75	2.75	0.93/1.50	40.70
8/(40)	8/40		2.90	5.20	4.00	
8/12	8/12		2.50	3.80	2.50	
8	8		4.55	6.80	9.00	
(100)	100		4.40	7.00	10.00	
(100/60)	100/60		3.40	5.50	6.00	

() = metric

Note: Size 16 contacts - gold plating only. Size 12, 8 & 100, silver or gold plating. For gold, add 'P3' to part number.

INSERT ARRANGEMENTS

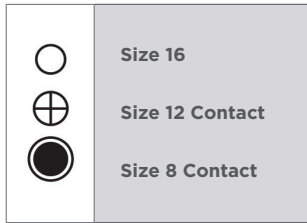

7 Contacts

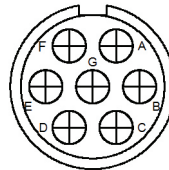

20-15
Service A
7 Contacts,
Size #12 (25)

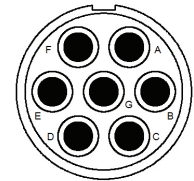

24-10
Service A
7 Contacts,
Size #8 (100)

10 Contacts

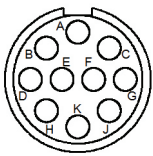

18-19
Service A
10 Contacts,
Size #16 (15)

13 Contacts

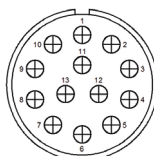

32-A13
Service D
13 Contacts,
Size #12 (25)

19 Contacts

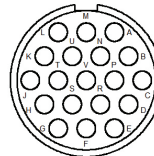

22-14
Service A
19 Contacts,
Size #16 (15)

22 Contacts

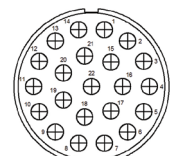

36-A22
Service D
22 Contacts,
Size #12 (25)

35 Contacts

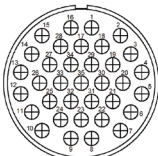

40-A35
Service D
35 Contacts,
Size #12 (25)

37 Contacts

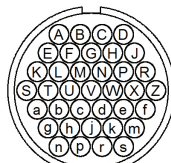

28-21
Service A
37 Contacts,
Size #16 (15)

60 Contacts

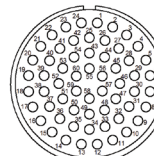

40-A60
Service A
60 Contacts,
Size #16 (15)

Note: Views from front face of pin insert

Position of Orientation Identifier on Insulator Moulding

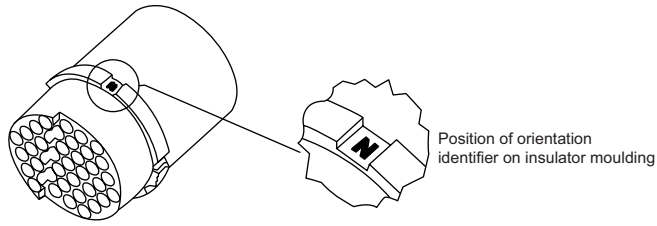

View of Mating Face of Pin Inserts

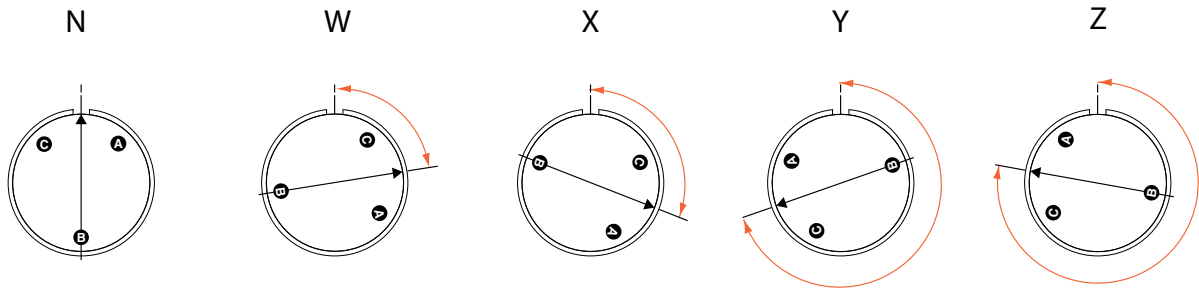

Contact Arrangement	Angular Displacement of Inserts				
	N YELLOW	W BLUE	X GREEN	Y PURPLE	Z WHITE
18-19	0	-	120	240	-
20-15		80	-	-	280
22-14			110	250	
24-10			-	-	
28-21		110	250		
32-A13		65	130	230	295
36-A22		80	110	250	280
40-A35		70	130	230	290
40-A60		80	110	250	280



Contact Arrangement	Insulator Orientation	Alignment / Polarising Pin Position
18-19	ALL	Any one hole
20-15		Any one hole apart from G
22-14		Holes K & R
24-10		Any one hole apart from G
28-21		Holes E & e
32-A13		Hole 10
36-A22		Holes 14 & 17
40-A35		Holes 1 & 24
40-A60	N	Holes 3 & 51
	W, X, Y & Z	Holes 26 & 59

How to Order:
CIRP ** FAP
** Contact

Note: Consult TE for all other positions.

CIRP03T

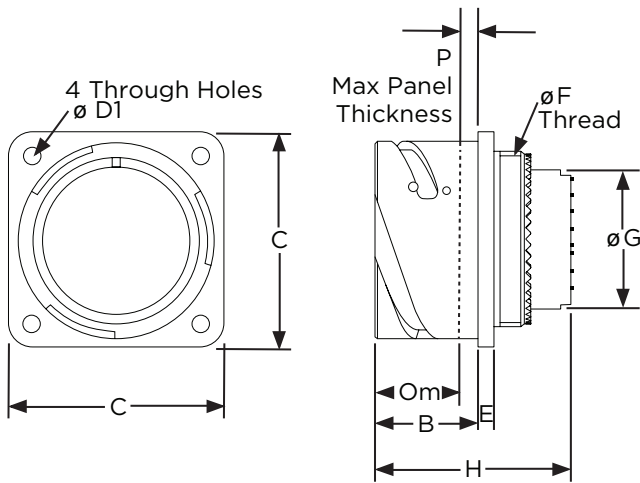

Shell Size	ϕF Thread Class 2A	B Max	C Max	$\phi d1$ +0,2-0	Threaded Holes (MOD CODE M6)	E Max	ϕG	H	P see note	Om Min Overlap Mated
18	1" x 20 UNEF	23.45	35.30	3.20	M3	4.20	18.30	46.25	3.30	15.85
20	1 1/8" x 18 UNEF		38.30				20.50			
22	1 1/4" x 18 UNEF		41.30				24.60			
24	1 3/8" x 18 UNEF	44.80	27.00							
28	1 5/8" x 18 UNEF	24.45	51.10	4.30	M5		32.50			15.75
32	1 7/8" x 16 UN		57.30				35.80			
36	2 1/16" x 16 UNS		63.80				42.50			
40	2 5/16" x 16 UN		70.20				48.50			

Note: Maximum panel thickness when using cap head screws.
When using countersunk screws, maximum panel thickness = 7.5mm.

See page 35 for panel mounting details

CIRP00T

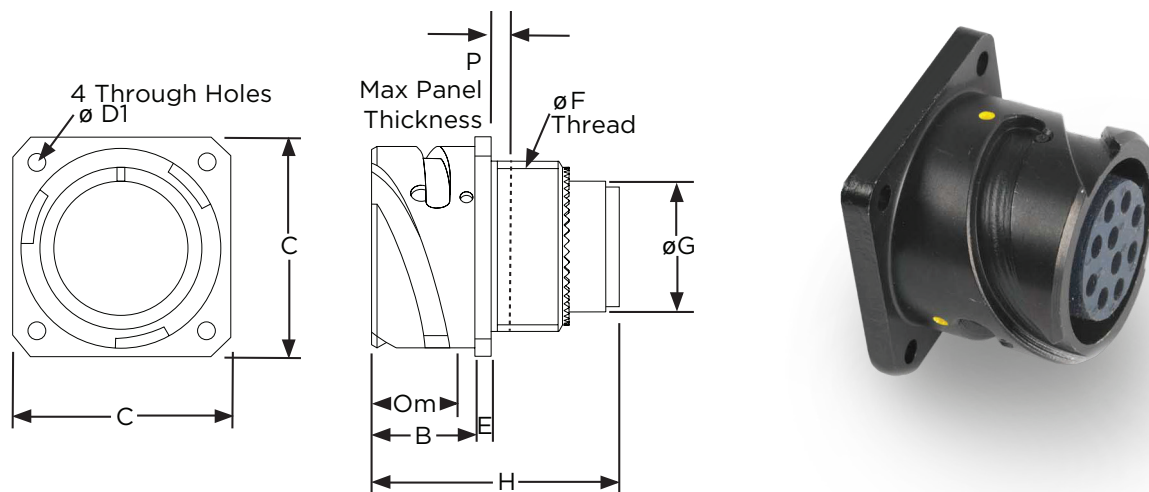

Shell Size	ØF Thread Class 2A	B Max	C Max	Ød1 +0,2-0	Threaded Holes (MOD CODE M6)	E Max	ØG	H	P see note	Om Min Overlap Mated
18	1" x 20 UNEF	23.60	35.30	3.20	M3	4.20	18.30	46.25	3.30	15.85
20	1 1/8" x 18 UNEF		38.30				20.50			
22	1 1/4" x 18 UNEF		41.30				24.60			
24	1 3/8" x 18 UNEF	44.80	27.00							
28	1 5/8" x 18 UNEF	25.20	51.10	4.30	M5		32.50			15.75
32	1 7/8" x 16 UN		57.30				35.80			
36	2 1/16" x 16 UNS		63.80				42.50			
40	2 5/16" x 16 UN		70.20				48.50			

Note: Maximum panel thickness when using cap head screws.
 When using countersunk screws, maximum panel thickness = 7.5mm.

See page 35 for panel mounting details

CIRPSE06T****

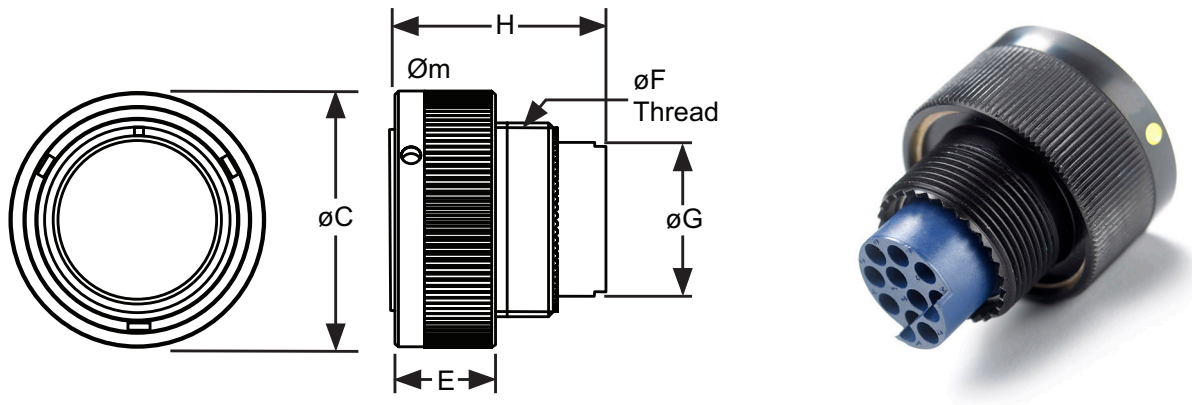

Shell Size	C Max	E Max	$\varnothing F$ Thread Class 2A	$\varnothing G$	H	Om Min Overlap Mated
18	37.30	24.00	1" x 20 UNEF	18.30	46.25	15.85
20	40.70		1 1/8" x 18 UNEF	20.50		
22	44.20		1 1/4" x 18 UNEF	24.60		
24	47.70		1 3/8" x 18 UNEF	27.00		
28	54.50		1 5/8" x 18 UNEF	32.50		
32	61.40	27.00	1 7/8" x 16 UN	35.80	15.75	
36	68.00		2 1/16" x 16 UNS	42.50		
40	74.00		2 5/16" x 16 UN	48.50		

Note: All plug connectors are EMI/RFI versions.

CIRP09T

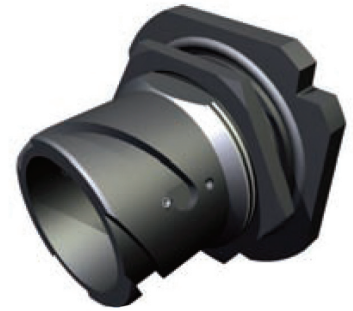
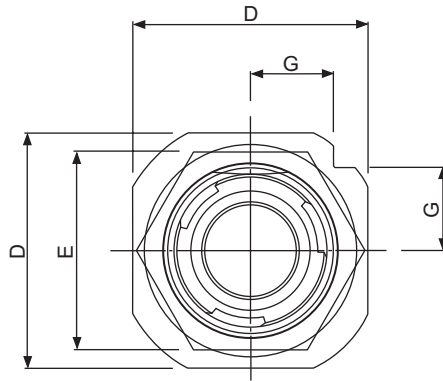
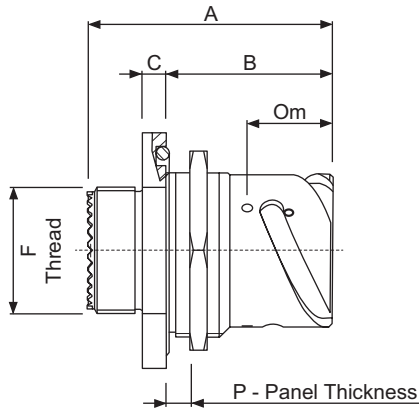

Shell Size	A Max	B	C	D Max	E	ØF Thread Class 2A	ØG	P		Om Min Overlap Mated
								Min	Max	
18	49.55	33.70	4.80	47.85	39.70	1" x 20 UNEF	16.80	2.40	9.00	15.85
20				51.05	44.00	1 1/8" x 18 UNEF	18.00			
22				54.45	46.00	1 1/4" x 18 UNEF	20.20		9.10	
24				57.45	50.80	1 3/8" x 18 UNEF	20.20			
28	52.15	35.20	5.60	63.75	55.00	1 5/8" x 18 UNEF	22.50		8.50	15.75
32				70.05	62.00	1 7/8" x 18 UNEF	24.70			
36				76.45	71.00	2 1/16" x 18 UNS	26.90		8.30	
40				83.75	75.00	2 5/16" x 18 UN	29.60			

PLUG CONNECTOR WITH PROTECTIVE RUBBER RING (STYLE 'T' LESS ACCESSORIES)

CIRPPSE06T****

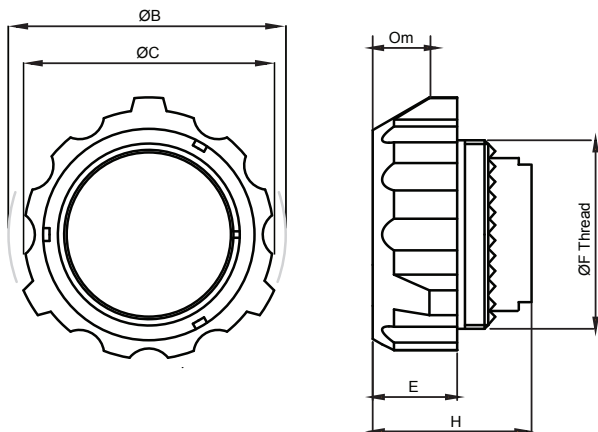

Shell Size	B Max	C Max	E Max	ØF Thread Class 2A	H Max	Om Min Overlap Mated
18	49.00	43.50	27.10	1" x 20 UNEF	46.82	17.85
20	51.50	46.00		1 1/8" x 18 UNEF		
22	56.00	50.50		1 1/4" x 18 UNEF		
24	60.00	54.00		1 3/8" x 18 UNEF		17.75
28	67.00	61.00		1 5/8" x 18 UNEF		
32	76.00	67.60		1 7/8" x 16 UN		
36	82.30	74.30		2 1/16" x 16 UNS		
40	88.00	80.00		2 5/16" x 16 UN		

Note: All plug connectors are EMI/RFI versions.

LOCKING BACKNUT FOR GROMMET SEALING ONLY - LBN

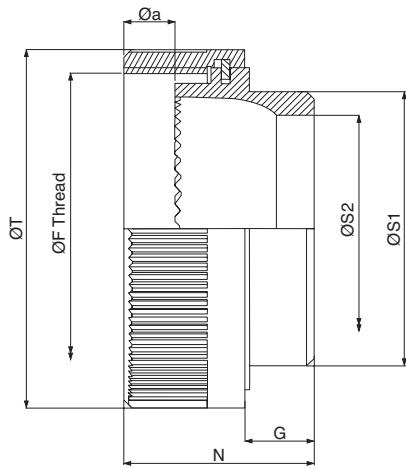

Shell Size	ØF Thread Class 2A	G Max	N Max	ØS1 Max	ØS2 Max	ØT Max	Oa Min Overlap Accessory
18	1" x 20 UNEF	8.70	25.65	25.50	16.70	31.00	7.00
20	1 1/8" x 18 UNEF			30.20	19.80	35.00	
22	1 1/4" x 18 UNEF					38.00	
24	1 3/8" x 18 UNEF		24.65	36.60	25.40	41.00	
28	1 5/8" x 18 UNEF				27.00	48.00	
32	1 7/8" x 16 UN			44.50	32.50	54.00	
36	2 1/16" x 16 UNS			50.90	35.70	61.00	
40	2 5/16" x 16 UN			57.20	45.00	67.00	

How to Order:
 CIRBP ** LBN
 ** Shell Size

STRAIGHT CONDUIT HEATSHRINK SCREEN ADAPTER – SCHSA (LOCKING)

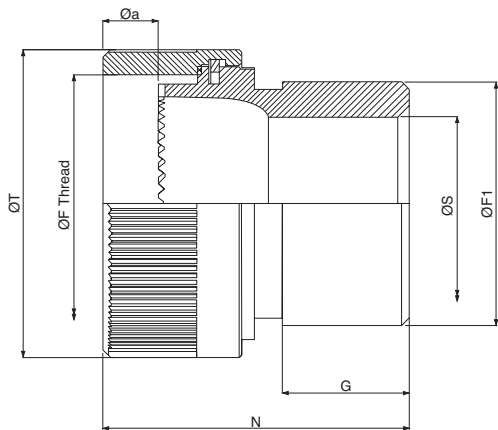

Shell Size	ØF Thread Class 2B	ØF1 Thread Class 2A	G Max	N Max	ØS Min	ØT Max	Oa Min Overlap Accessory
18	1" x 20 UNEF	1" x 20 UNEF	12.40	36.06	16.70	31.00	7.00
20	1 1/8" x 18 UNEF	1 3/16" x 18 UNEF		38.60	19.80	35.00	
22	1 1/4" x 18 UNEF				21.34	38.00	
24	1 3/8" x 18 UNEF	1 7/16" x 18 UNEF		38.56	25.40	41.00	
28	1 5/8" x 18 UNEF				30.13	48.00	
32	1 7/8" x 16 UN	1 3/4" x 18 UNS	12.10	38.26	36.73	54.00	
36	2 1/16" x 16 UNS	2" x 18 UNS		39.26	41.00	61.00	
40	2 5/16" x 16 UN	2 1/4" x 16 UN		38.30	48.10	67.00	

How to Order:

CIRBP ** SCHSA

** Shell Size

90° ELBOW CONDUIT HEATSHRINK SCREEN ADAPTER - ECHSA (LOCKING)

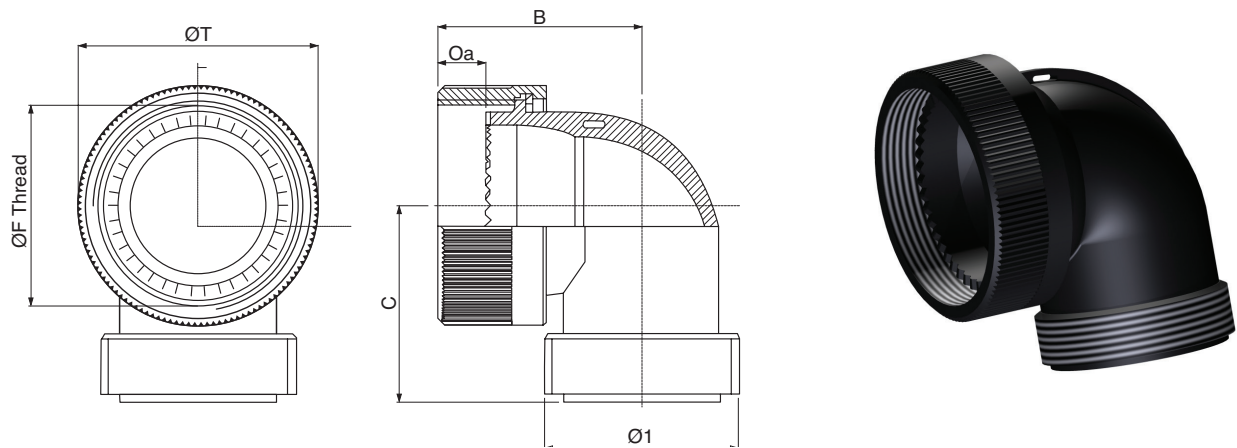

Shell Size	ØF Thread Class 2B	Ø1 Original Thread Class 2B	B Max	C Max	ØT Max	Oa Min Overlap Accessory
18	1" x 20 UNEF	1" x 20 UNEF	31.10	35.00	31.00	7.00
20	1 1/8" x 18 UNEF	1 3/16" x 18 UNEF	33.00		35.00	
22	1 1/4" x 18 UNEF		33.10		38.00	
24	1 3/8" x 18 UNEF	1 7/16" x 18 UNEF	37.90	40.00	41.00	
28	1 5/8" x 18 UNEF		37.10		48.00	
32	1 7/8" x 16 UN	1 3/4" x 18 UNS	43.10	45.00	54.00	
36	2 1/16" x 16 UNS	2" x 18 UNS	45.90	50.00	61.00	
40	2 5/16" x 16 UN	2 1/4" x 16 UN	49.00	54.60	67.00	

How to Order:

CIRBP ** ECHSA

** Shell Size

Note: ECHSA can be locked in multiple angles / positions.

**SHELL HEATSHRINK EXTENDER - SHE (PG / METRIC
INNER THREAD - IMPERIAL OUTER THREAD) (LOCKING)**

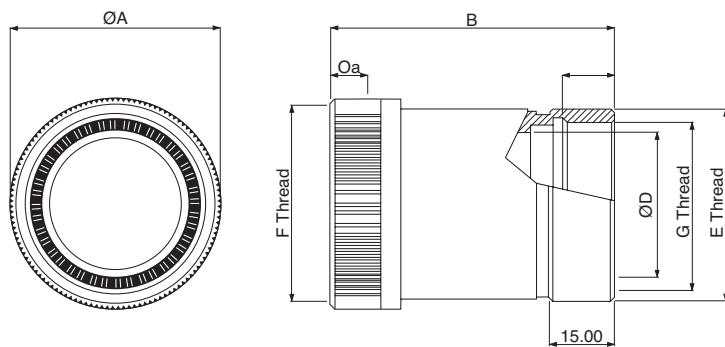

Shell Size	F Thread Class 2B	E Thread Class 2A	G Thread PG/METRIC	ØA Max	B	Overlap Oa Min
18	1" x 20 UNEF	1" x 20 UNEF	PG 13.5 M20x1.5	31.00	58.8	7.00
20	1 1/8" x 18 UNEF	1 3/16" x 18 UNEF	PG 16 M25x1.5	35.00		
22	1 1/4" x 18 UNEF			38.00		
24	1 3/8" x 18 UNEF	1 7/16" x 18 UNEF	PG 21 M32x1.5	41.00	65.8	
28	1 5/8" x 18 UNEF			48.00		
32	1 7/8" x 16 UN	1 3/4" x 18 UNS	PG 29 M40x1.5	54.00		
36	2 1/16" x 16 UNS			61.00		
40	2 5/16" x 16 UN	2 1/4" x 16 UN	PG 36 M50x1.5	67.00		

How to Order:

CIRBP *** SHE #

** Shell Size & Planform
M = Metric, P = PG

**STEP-UP ADAPTERS - SUA (PG / METRIC INNER
THREAD - IMPERIAL OUTER THREAD) (LOCKING)**

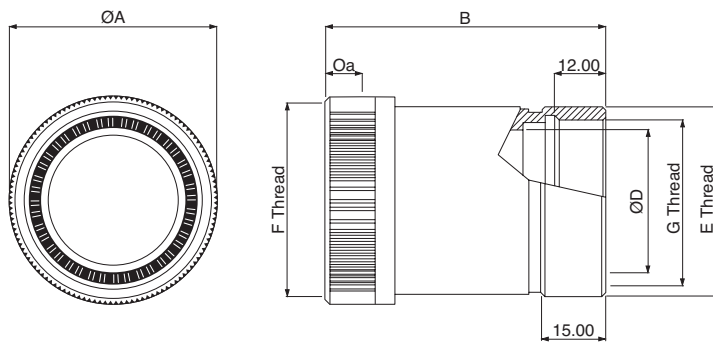

Shell Size	F Thread Class 2B	E Thread Class 2A	G Thread PG/METRIC	ØA Max	B	ØD Bore	Overlap Oa Min
18	1" x 20 UNEF	1 3/16" x 18 UNEF	PG 16 M25x1.5	31.00	58.8	16.7	7.0
20	1 1/8" x 18 UNEF	1 7/16" x 18 UNEF	PG 21 M32x1.5	35.00		19.8	
22	1 1/4" x 18 UNEF			38.00		25.4	
24	1 3/8" x 18 UNEF	1 3/4" x 18 UNS	PG 29 M40x1.5	41.00	65.8	27.0	
28	1 5/8" x 18 UNEF			48.00		32.5	
32	1 7/8" x 16 UN			54.00		35.7	
36	2 1/16" x 16 UNS			2" x 18 UNS		PG 36 M50x1.5	
40	2 5/16" x 16 UN	2 1/4" x 16 UN	PG 42 M50x1.5	67.00			

How to Order:

CIRBP ** ** SUA #

** Shell Size & Platform
M = Metric, P = PG

STEP-DOWN ADAPTERS - SDA (PG / METRIC INNER THREAD - IMPERIAL OUTER THREAD)

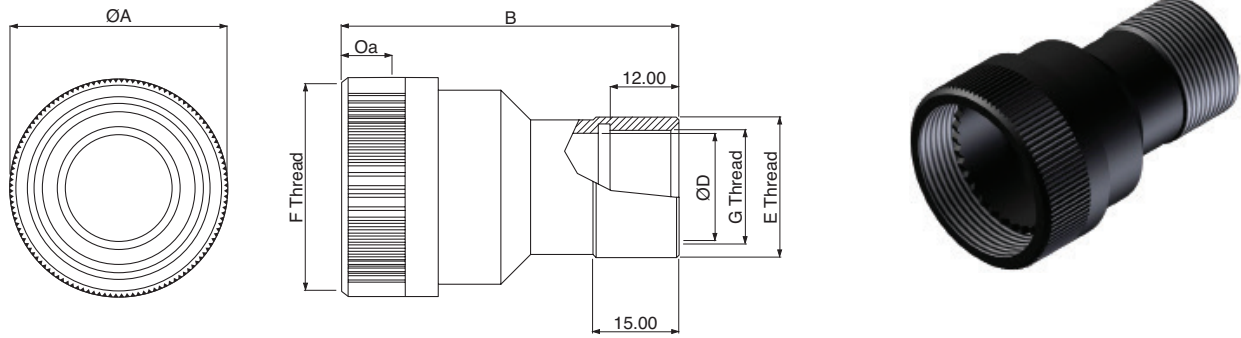

Shell Size	F Thread Class 2B	E Thread Class 2A	G Thread PG/METRIC	ØA Max	B	Overlap Oa Min
18	1" x 20 UNEF	7/8" x 18 UNEF	PG 11 M18x1.5	31.00	58.8	
20	1 1/8" x 18 UNEF	1" x 20 UNEF	PG 13.5 M20x1.5	35.00		
22	1 1/4" x 18 UNEF			38.00		
24	1 3/8" x 18 UNEF	1 3/16" x 18 UNEF	PG 16 M25x1.5	41.00	65.8	
28	1 5/8" x 18 UNEF			48.00		
32	1 7/8" x 16 UN	1 7/16" x 18 UNEF	PG 21 M32x1.5	54.00		
36	2 1/16" x 16 UNS	1 3/4" x 18 UNEF	PG 29 M40x1.5	61.00		
40	2 5/16" x 16 UN	1" x 18 UNS		67.00		

How to Order:

CIRBP** ** SDA#

** Shell Size & Planform
M = Metric, P = PG

CABLE GLAND ADAPTERS (FITTING ON SCHSA & ECHSA ACCESSORY WITH PG / METRIC THREAD)

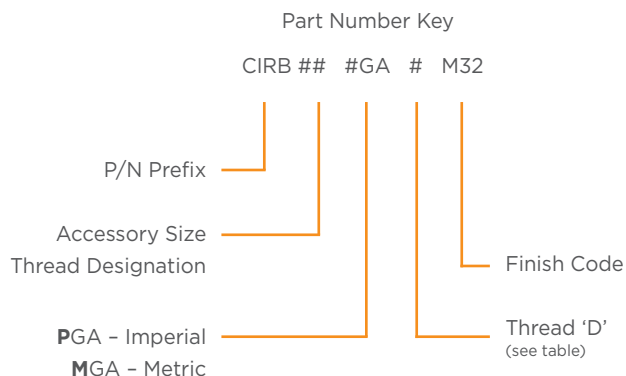
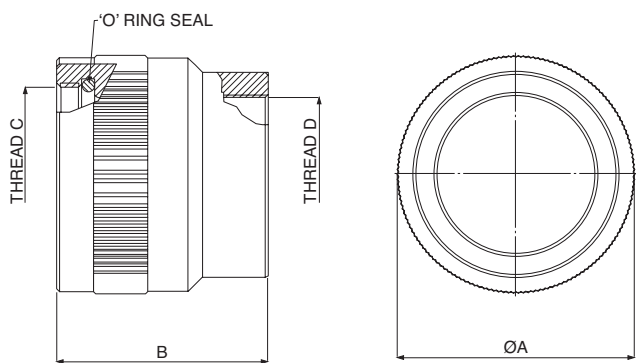

P/N Example to fit shell size 20 with a rear metric thread size M25
TEB 20 MGA DM32

Shell Size	Part Number	ØA	B	Thread C
18	CIRB-18-#GA-#M32	34.00	40.00	1" x 20 UNEF
20-22	CIRB-20-#GA-#M32	37.00	35.00	1 3/16" x 18 UNEF
20-22	CIRB-20-#GA-#M32			
24-28	CIRB-24-#GA-#M32	43.00	40.00	1 7/16" x 18 UNEF
24-28	CIRB-24-#GA-#M32			
24-28	CIRB-24-#GA-#M32	54.00	46.00	1 3/4" x 18 UNS
32	CIRB-32-#GA-#M32		38.00	
36	CIRB-36-#GA-#M32	57.20	50.00	2" x 18 UNS
40	CIRB-40-#GA-#M32	65.00		2 1/4" x 16 UN

Thread Table (D)			
Imperial (PGA)	Thread Size	Metric (MGA)	Thread Size
A	PG7	A	M12
B	PG9	B	M16
C	PG11	C	M20
D	PG13.5	D	M25
E	PG16	E	M32
F	PG21	F	M40
G	PG29	G	M50
H	PG36	H	M63
J	PG42		
K	PG48		

SHELL EXTENDER WITH SCREENING - SPTAS (NON LOCKING)

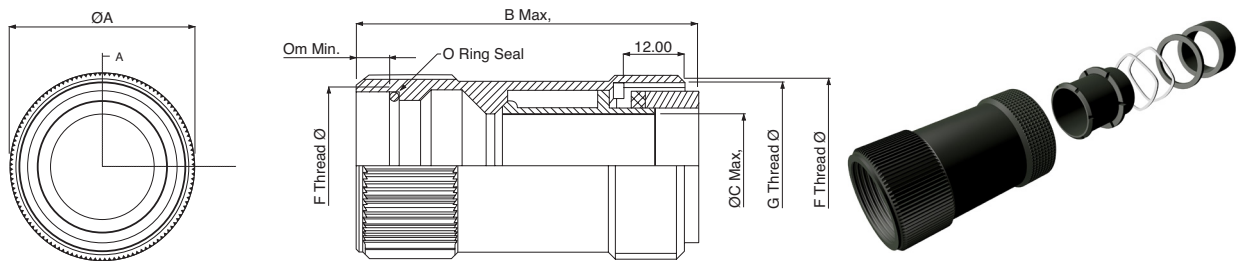

Shell Size	ØA	B Max	ØC Max	ØF Thread Class 2B	G Thread	ØH Thread Class 2A
18	29.50	68.00	11.30	1 x 20 UNEF	M25x1.5-6H	1 3/16" x 18 UNEF
20*	-	-	-	-	-	-
22	36.50	68.00	21.00	1 3/16" x 18 UNEF	M32x1.5-6H	1 7/16" x 18 UNEF
24*	-	-	-	-	-	-
28	43.00	70.00	27.50	1 7/16" x 18 UNEF	M40x1.5-6H	1 3/4" x 18 UN
32*	-	-	-	-	-	-
36*	-	-	-	-	-	-
40	64.00	70.00	39.00	2 1/4" x 16 UN	M50x1.5-6H	2 1/4" x 16 UN

How to Order:

CIRBP** ** SPTAS #

** Shell Size & Platform
M = Metric, P = PG

Note: * Please consult TE for these sizes

ADAPTERS - CRA (2 PIECE ADAPTOR TO TERMINATE CABLE SCREEN BRAID TO CONNECTOR WITH CONDUIT OUTER)

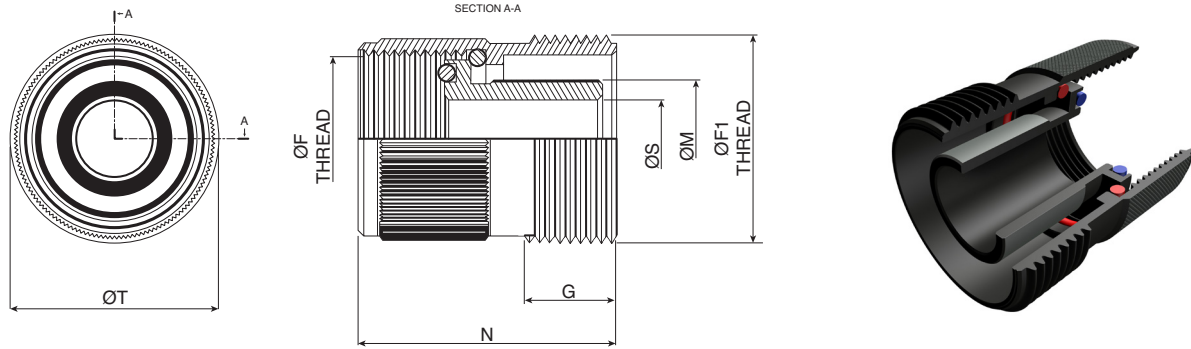

Shell Size	ØF Thread Class 2B	ØF1 Thread Class 2A	G Max	N Max	S Min	T Max	M Max
16S	7 1/8" x 20 UNEF	1" x 20 UNEF	10.00	27.60	9.74	25.50	13.10
18	1" x 20 UNEF	1 3/16" x 18 UNEF	11.00	30.60	12.90	29.10	16.26
20	1 3/16" x 18 UNEF	1 7/16" x 18 UNEF			18.23	35.45	21.51
22					1 7/16" x 18 UNEF	1 3/4" x 18 UNS	25.93
24	1 3/4" x 18 UNS	2" x 18 UNS					49.55
28			2" x 18 UNS	2 1/4" x 16 UN	32.00	55.90	35.19
32	2 1/4" x 16 UN	2 1/4" x 16 UN			32.33	63.10	35.60
36			32.33	63.10	35.60		
40							

How to Order:
 CIRB ** CRA M32

 ** Shell Size

Note: This accessory can only be used in conjunction with style SCHSA or ECHSA adaptors.

WATERPROOF CLAMP FOR JACKETED CABLE - CIRMSP3057C

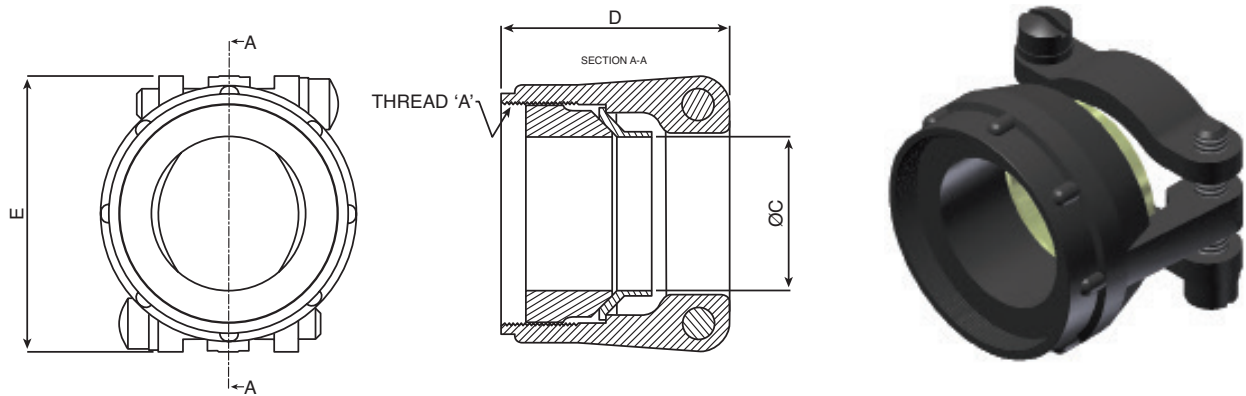

Shell Size	Part Number CIRMSP3057C**M32	ØA Thread Class 2A	ØC		D Max	E Max		
			Min	Max				
16 / 16S	16 / 16S	7 1/8" x 20 UNEF	7.92	13.48	34.93	30.18		
18	18	1" x 20 UNEF	9.53	15.87	36.50	33.32		
20	20	1 3/16" x 18 UNEF	12.70	19.00		39.21		
22	22		24	24	1 7/16" x 18 UNEF	15.09	23.80	39.67
28	28	32	32	1 3/4" x 18 UNS	23.83	31.75	46.02	57.15
36	36	2" x 18 UNS	24.61	35.00	52.37	60.33		
40	40	2 1/4" x 16 UN	30.18	41.25		66.68		

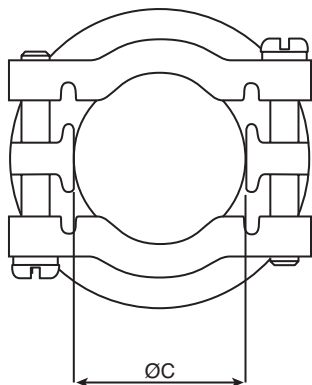
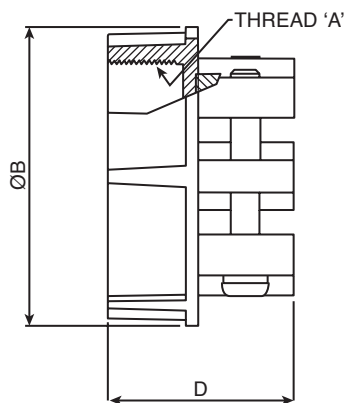

Shell Size	Part Number CIRMSP3057A**M32	ØA Thread Class 2A	B Max	C Max	D Max
16 / 16S	16 / 16S	7 1/8" x 20 UNEF	28.58	14.30	24.61
18	18	1" x 20 UNEF	30.96	15.88	
20	20	1 3/16" x 18 UNEF	35.71	19.05	
22	22				
24	24	1 7/16" x 18 UNEF	42.85	23.83	26.97
28	28				
32	32	1 3/4" x 18 UNS	52.37	31.75	28.58
36	36	2" x 18 UNS	57.15	34.93	30.15
40	40	2 1/4" x 16 UN	64.29	41.28	43.66

**TELESCOPIC BUSHING – CIRSBMSH554
(USE WITH CIRMSP3057A CLAMP)**

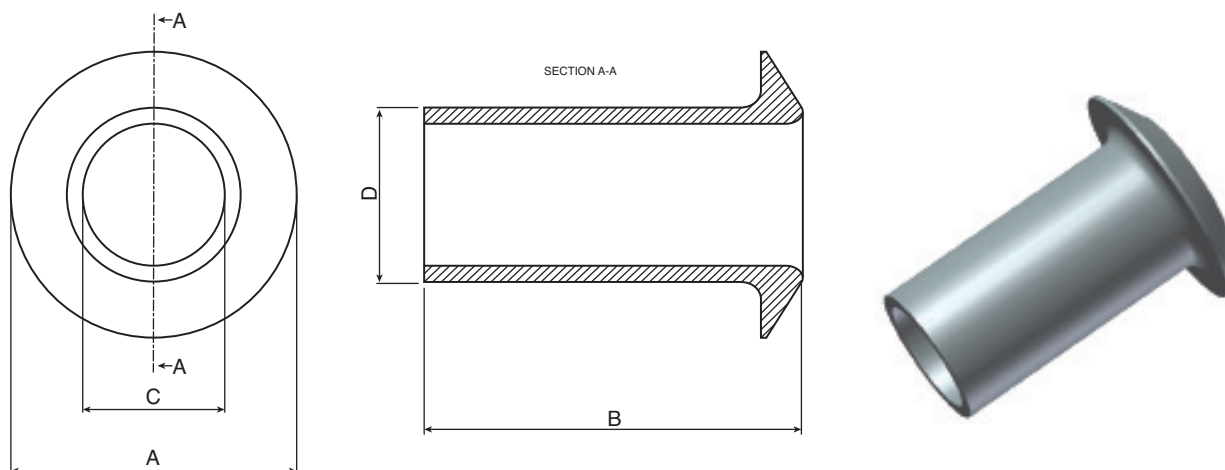

Shell Size	Part Number CIRSBMSH554**	ØA	B	ØC	ØD
16 / 16S	3	19.05	63.50	11.10	13.97
18	4	22.23	60.33	14.27	15.57
20	5	25.40	57.15	15.88	18.75
22	6	28.58			
24	7	31.75	53.98	19.05	23.50
28	8	38.23			
32	9	44.45	50.80	23.80	31.45
36	10	47.88	47.63	31.75	34.62
40	11	52.90	44.40	34.92	40.99

Note: Through bore reduction possible by telescoping bushings

**PANEL GASKET, NON-CONDUCTIVE /
CONDUCTIVE FRONT & REAR MOUNTED
CONNECTORS - RPG/S & FPG/S**

CIRSBRPG / RPGS**

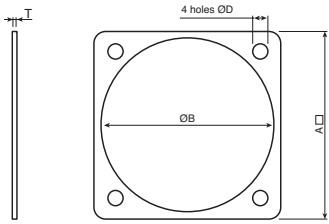

CIRSBFPG / FPGS**

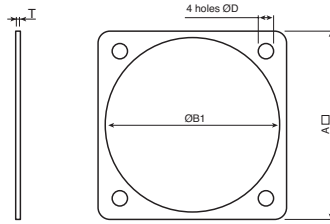

Shell Size	A Min	ØB Nominal	ØB1 Nominal	Ød Min	T Nominal
18	34.90	25.40	30.90	3.43	1.00
20	38.10	28.60	34.30		
22	41.30	31.70	37.50		
24	44.50	34.90	41.00	4.12	
28	50.80	41.30	46.80		
32	57.20	47.60	53.50	4.78	
36	63.50	52.60	59.70		
40	69.90	61.90	65.50	5.10	

How to Order:		
Part Numbers:		
	Non-conductive	Conductive
Front Mounted	CIRSB ** RPG	CIRSB ** RPGS
Rear Mounted	CIRSB ** FPG	CIRSB ** FPGS

** Shell Size

Note: Conductive gaskets have a conductivity of 5m Ohms, temp range of -50 to +200 °C.

CONNECTOR FIXING NUT PLATES

CIRB**NP

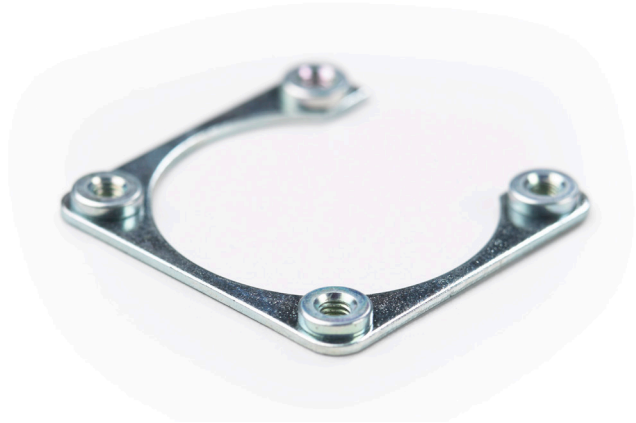
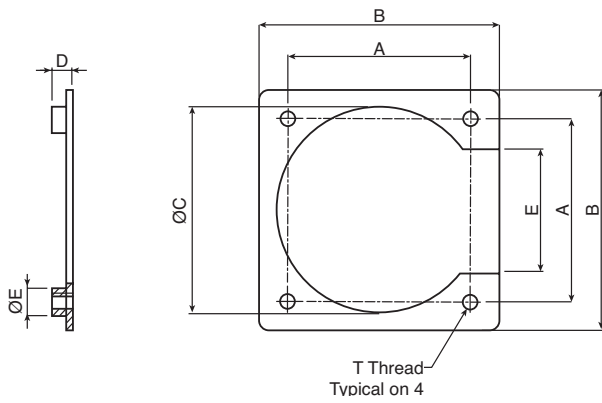

Shell Size	A	B Max	CØ Max	D	E Max	FØ Max	T Thread (Metric)	Part Number CIRB**NP	T Thread (Imperial)	Part Number CIRB**NPA
18	26.97	34.62	30.48	2.69/4.22	20.21	6.00	M3x0.5	18	4-40 UNC	18
20	29.36	38.48	33.53		22.47			20		20
22	31.75	40.84	36.65		23.54			22		22
24	34.93	44.83	40.00		25.90	24		24		
28	39.67	51.18	46.61		29.08	28		28		
32	44.45	59.10	52.75	3.50/5.00	30.68	8.00	M4x0.7	32	8-32 UNC	32
36	49.23	63.86	59.10		35.43			36		36
40	55.58	74.68	68.33		38.60			40		40

GROMMET FILLER



Damage to Grommet



Grommet Filler Plug

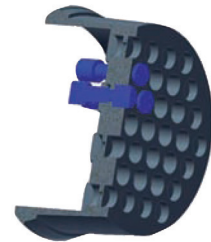

Sealed using Filler Plugs

CIRB16KFP -
 CIRB12KFPPF80 - To be used if grommet is pierced incorrectly
 CIRB8KFPPF80 -

Front Mounting Receptacle

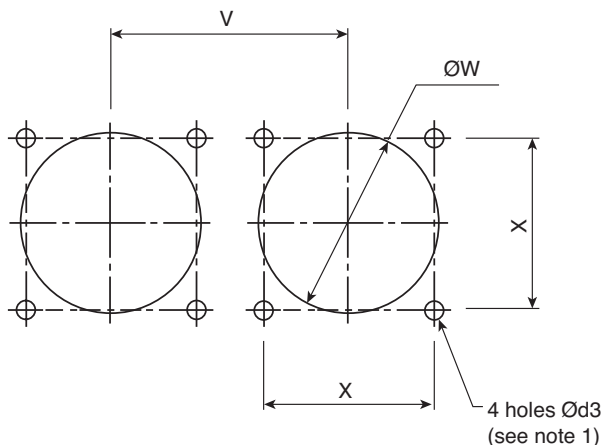

Rear Mounting Receptacle

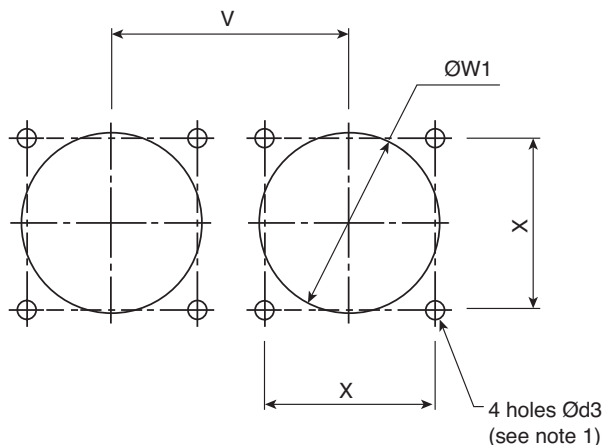

Shell Size	Ød3	Ød4	V	ØW	ØW1	X
18	3.40	4.50	38.30	26.00	31.18	27.00
20			41.70	30.00	34.58	29.40
22			45.20	33.00	37.78	31.80
24	3.90		48.70	36.00	41.28	34.90
28			55.50	42.00	47.08	39.70
32	4.50	5.50	62.40	48.50	53.78	44.50
36			69.00	55.00	59.98	49.20
40			75.00	59.10	66.40	55.50

Hole centres	ØJ	K
48.85	35.23	33.58
52.05	38.43	36.68
55.45	41.56	39.88
58.45	44.78	43.18
65.25	51.13	49.37
71.55	57.48	55.78
77.95	63.83	62.18
85.25	70.18	68.38

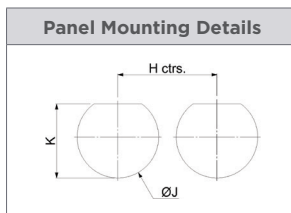

Note: When fixed connectors are used with threaded mounting holes, refer to hole sizes in column Ød4.



CIRBE**XPCA M32 (with nylon cord)

CIRBE**XPCA M32 (with sash chain)

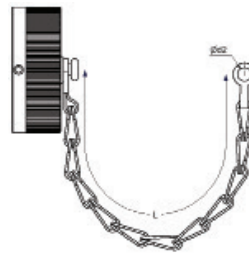
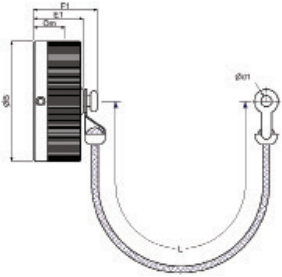

CIRB**EPCA M32 (with nylon cord)

CIRB**EPCA M32 (with sash chain)

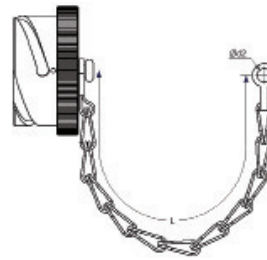
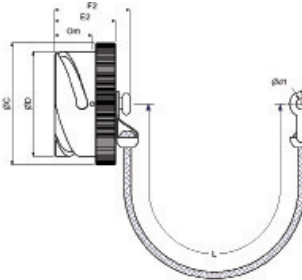

Shell Size	B Max	C Max	D Max	E1 Max	E2 Max	F1 Max	F2 Max	L (approx)	d1 Min	d2 +0.5, -0 +0.02, -0	Om Min Overlap Mated
18	36.50	38.70	30.80	24.00	27.30	29.80	33.90	150.0	4.85	4.30	15.85
20	39.90	42.10	34.20								
22	43.10	45.30	37.40								
24	46.60	48.80	40.90								
28	53.40	54.60	46.70	27.00	27.30	29.80	33.90	150.0	4.85	5.50	15.75
32	60.10	61.30	53.40								
36	66.30	67.50	59.60								
40	72.10	73.40	65.50								

RFI Braid Sock

TE Connectors Part Number	Diameter	Length	Max Shell Size
CIRBMS035015	ø 20 mm	100 mm	22
CIRBMS050015	ø 25 mm	150 mm	22
CIRBMS020010	ø 35 mm	150 mm	32
CIRBMS025015	ø 50 mm	150 mm	36 & 40

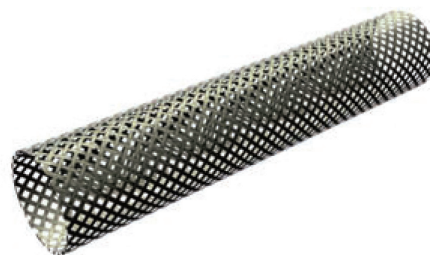

Bandit Strap

TE Connectors Part Number	Length	Width	Max Shell Size
CIRB600052	520 mm	6.1 mm	32
CIRB600090	900 mm	6.1 mm	36 & 40
CIRB608109	362 mm	4 mm	22
CIRB600057	07 mm	3 mm	22

Bandit Tools

TE Connectors Part Number	Tool Description
CIRB600058	Standard Bandit Tool
CIRB600061	Micro Bandit Tool (3mm Band Straps)
CIRB601200	Calibration Kit

Knitmesh Braid

TE Connectors Part Number	Length	Width
CIRBMKM1050	500 mm	25 mm

Tooling for crimp contacts

TE Connectors Part Number	Description	Size	Supplier Part Number
CIRBFT8	Hand Crimp Tool	Contact sizes 12 and 16	Supplier DMC part no: FT8
CIRWA27F	Pneumatic Crimp Tool (to locate contacts within a crimp tool)	Contact sizes 12 and 16	Supplier DMC part no: WA27F
CIRBTH592	Turret Locator	Contact sizes 12 and 16	Supplier DMC part no: TH592
CIRBD51	Hand Crimp Tool	Contact size 100	Supplier Dubuis part no: D51
CIRBD55E	Electric Crimp Tool	Contact size 100	Supplier Dubuis part no: D55E
CIRMRP0925	Die Sets	Crimping contact size 8 & 100	
CIR8012ITL (size 12) CIR8016ITL (size 16)	Insertion Tool (to insert contact into plastic insert)	Contact sizes 12 and 16	Supplier Astro Tools part no: AT 1110
CIR808ETA	Extraction Tool (to locate contacts within a crimp tool)	Contact size 8	
CIR8012ETA (size 12) CIR8016ETA (size 16)	Extraction Tool (to extract from plastic insert)	Contact sizes 12 & 16	
CIR8012GET (size 12) CIR8016GET (size 16)	Grommet Extraction Tool (to extract contact through grommet)	Contact sizes 12 & 16	

Supplementary Tooling

TE Connectors Part Number	Description	Size	Supplier Part Number
CIR6M3800644	Contact Retention Tester (applies a load to test contact is seated)correctly)		Supplier DMC part no: HT250-3
CIR6M3800731 (size 12) CIR6M3800646 (size 16)	Contact Socket Retention Test Probe	Contact sizes 12 & 16	Supplier DMC part no: 67-012-01/67-016-01
CIR6M3800730 (size 12) CIR6M3800645 (size 16)	Contact Pin Retention Test Probe	Contact sizes 12 & 16	Supplier DMC part no: 68-012-01/68-016-01
CIR8018GAT (size 18-24) CIR8028GAT (size 28-40)	Grommet Assembly Aid (to tuck grommet shoulder into connector)	Shell size 18-24/28-40	
CIR80 ## CAG (size & planform ##)	Pin Contact Alignment Gauge (checks/straightens contacts bent during assembly)		

Dotted lines for note-taking.

Dotted lines for writing notes.



For More Information

Follow us on Twitter for all the latest product news
@TEConnectivity, and on Facebook, TEConnectivity.

TE Connectivity (TE) Technical Support Center

North America +1 800 522 6752
Asia Pacific +86 0 400 820 6015
Austria +43 1 905 601 228
Baltic Regions +46 8 5072 5000
Benelux +31 73 6246 999
Czech Republic +420 800 701 462
France +33 1 34 20 86 86
Germany +49 6251 133 1999
Hungary +36 809 874 04
Italy +39 011 401 2632
Nordic +46 8 5072 5000
Poland +48 800 702 309
Russia +7495 790 790 2
Spain/Portugal +34 93 2910366
Switzerland +41 52 633 66 26
United Kingdom +44 800 267 666

te.com/Rail

© 2016 TE Connectivity Ltd. family of companies. All Rights Reserved. 1-1773857-9 RAIL 2/2016

EVERY CONNECTION COUNTS, TE Connectivity, TE connectivity (logo) and TE are trademarks of the TE Connectivity group of companies and its licensors.

SNCF, RATP, Alstom, Bombardier, LUL and other product or company names mentioned herein may be trademarks of their respective owners. While TE has made every reasonable effort to ensure the accuracy of the information herein, nothing herein constitutes any guarantee that such information is error-free, or any other representation, warranty or guarantee that the information is accurate, correct, reliable or current. The TE entity issuing this publication reserves the right to make any adjustments to the information contained herein at any time without notice. All implied warranties regarding the information contained herein, including, but not limited to, any implied warranties of merchantability or fitness for a particular purpose are expressly disclaimed.

The dimensions herein are for reference purposes only and are subject to change without notice. Specifications are subject to change without notice. Consult TE for the latest dimensions and design specifications.

X-ON Electronics

Largest Supplier of Electrical and Electronic Components

Click to view similar products for [Circular MIL Spec Connector](#) category:

Click to view products by [TE Connectivity](#) manufacturer:

Other Similar products are found below :

[89075GULPR](#) [0025-262-542](#) [0025-264-3014](#) [58-570121-04S](#) [0134-213-1208](#) [0134-213-2209](#) [0025-258-000](#) [60-042022-07P](#) [60-042022-19P](#)
[60-042022-23P](#) [60-042217-10P](#) [60-042217-11P](#) [0114-201-1278](#) [012-0467-000](#) [602GB06EG24-61SN](#) [0134-201-1207](#) [0134-213-1006](#) [6104-](#)
[207-2302](#) [6104-208-1902](#) [61-168211-04P](#) [61-168617-10P](#) [6131-202-19149P](#) [6131-204-21149P](#) [6131-208-13149P](#) [6131-209-17149P](#) [6131-](#)
[210-11149P](#) [6131-211-19149P](#) [6131-216-19149P](#) [6131-259-21149P](#) [6131-259-23149P](#) [6131-265-17149P](#) [6131-265-19149P](#) [CS3100A18-1P-](#)
[472](#) [CS3100A-36-77P](#) [CS3101A-16-55P](#) [CS3102A-10SL-55P](#) [CS3102A-14S-58P](#) [CS3102A-18-1P116](#) [CS3102A-32-17P](#) [CS3102A32-25S](#)
[CS3102C18-4P-472](#) [CS3106A10SL3S004](#) [CS3106A-18-73S](#) [CS3108A-14S-52S](#) [CS3108A-28-51S](#) [6162-233-1277](#) [6162-324-1231](#)
[M243082296Z](#) [M2884010AC1S1](#) [CT0-24-10SC](#)