

Figure 1

1. INTRODUCTION

AMPOWER Crimping Die Assemblies 68361-1, 68253-1, 68304-1, and 59867-1 (shown in Figure 1) are designed for use in DYNA-CRIMP Crimping Head 69099, which is hydraulically activated by Hydraulic Power Unit 69120-[] or Hydraulic Hand Pump 314979-1. Each die assembly, when installed in the crimping head, will crimp AMPOWER Quick-Disconnect Terminals onto standard wire sizes as listed in Figure 2. Read these instructions thoroughly before using the dies.

These instructions provide specific information regarding the die assemblies and applicable terminals. For information regarding die insertion/removal and general operation of the DYNA-CRIMP Crimping Head, refer to instruction sheet 408-2458. For information on the Hydraulic Power Unit, refer to customer manual 409-1950 and for information on the Hydraulic Hand Pump, refer to 409-5860.

Reasons for reissue are provided in Section 6, REVISION SUMMARY.

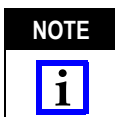

Dimensions in this instruction sheet are in metric units [with U.S. customary units in brackets]. Figures are not drawn to scale.

2. DESCRIPTION

Each die assembly features a stationary die, a moving die, and a locator assembly (refer to Figure 1). Both the stationary and moving die have a shank (with a flat) which is used to align and secure each die in the crimping head. The locator assembly is used to aid in positioning the terminal in the stationary die.

3. CRIMPING PROCEDURE

Install the dies according to the instructions contained in 408-2458. Refer to the table in Figure 2 and select the appropriate terminal and wire. Ensure that wire size stamped on terminal corresponds with wire size stamped on dies. Strip the wire to the length indicated. Do NOT cut or nick the wire strands.

Refer to Figure 3 and proceed as follows:



To avoid personal injury when operating power unit, exercise caution when holding terminals or wires near crimping area.

1. Position terminal in stationary die so that large, flat surface of terminal is parallel to and resting against angular surface of locator.
2. Hold the terminal in position and activate power unit so that moving die advances just enough to hold terminal in place. Do not deform terminal wire barrel.

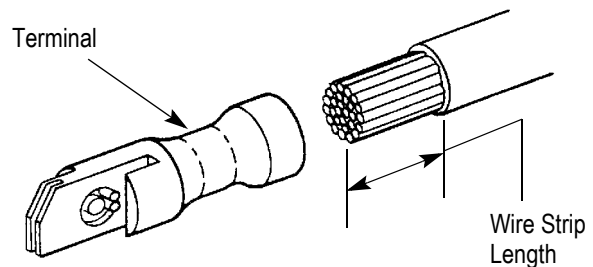

WIRE SIZE	WIRE STRIP LENGTH		TERMINAL NUMBER	DIE SET NUMBER
	MIN.	MAX.		
1/0			52594-1, 52594-3, and 52594-3	68361-1
2/0	29.46 [1.16]	30.99 [1.22]	52595-1	68253-1
3/0			52596-1	59867-1
4/0			53631-1	68304-1

Figure 2

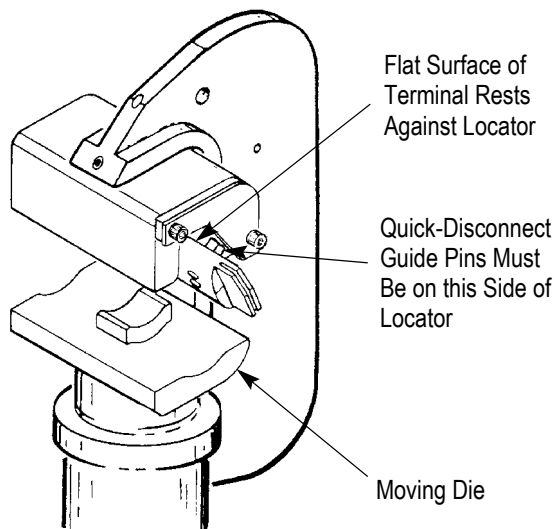

Figure 3

3. Insert stripped wire all the way into terminal wire barrel.
4. Hold the wire in place and activate power unit through a complete cycle.
5. Allow the dies to open fully, then remove the crimped terminal.

Inspect crimped terminals by comparing them to the ones shown in Figure 4. Use only the terminals that meet the conditions shown in the "ACCEPT" column. "REJECT" terminals can be avoided by carefully following the above procedures and by performing regular tool maintenance, as provided in Section 4, MAINTENANCE AND INSPECTION PROCEDURE.

4. MAINTENANCE AND INSPECTION PROCEDURE

It is recommended that a maintenance and inspection program be performed periodically to ensure dependable and uniform terminations. Frequency of inspection depends on:

- The care, amount of use, and handling of the dies.
- The presence of abnormal amounts of dust and dirt in your facility.
- The degree of operator skill.
- Your own established standards.

The dies are inspected before being shipped; however, it is recommended that the dies be inspected immediately upon their arrival at your facility to ensure that there was no damage during shipment. Due to the precision design, it is important that no parts of these dies be interchanged except those replacement parts listed in Figure 7.

4.1. Daily Maintenance

1. Remove dust, moisture, and other contaminants with a clean brush, or a soft, lint-free cloth. Do NOT use objects that could damage the dies.
2. All surfaces should be protected with a thin coat of any good SAE 20 motor oil. Do not oil excessively.
3. When the dies are not in use, store them in a clean, dry area.

4.2. Lubrication

To protect dies from rust when storing, lubricate all surfaces with SAE 20 motor oil. Before using dies, wipe off excess oil, particularly from crimping area. Oil transferred from the crimping area onto certain terminations may affect the electrical characteristics of the termination.

4.3. Periodic Inspection

1. Remove accumulated dirt, grease, and foreign matter by immersing the dies in a suitable commercial degreaser that will not affect paint or plastic material.
2. Inspect die crimp area for worn, cracked, or broken surfaces. If damage is evident, return the dies to TE for evaluation and repair. See Section 5, REPLACEMENT AND REPAIR.

4.4. Crimping Die Closure Inspection

This inspection requires the use of a plug gage conforming to the dimensions shown in Figure 5. TE does not manufacture or market this gage.

To gage die closure, refer to Figure 6 and proceed as follows:

1. Remove dies from crimping head.
2. Remove traces of oil or dirt from the crimping chambers and plug gage.
3. Assemble and adjust dies to meet the "gage dimension" indicated in Figure 6.
4. Align the GO element with the wire barrel crimping chamber. Push element straight into the crimping chamber without using force. The GO element must pass completely through the crimping chamber.
5. Check the wire barrel crimping chamber with the NO-GO element in the same manner as step 4. The NO-GO element may start entry, but must not pass completely through the crimping chamber.

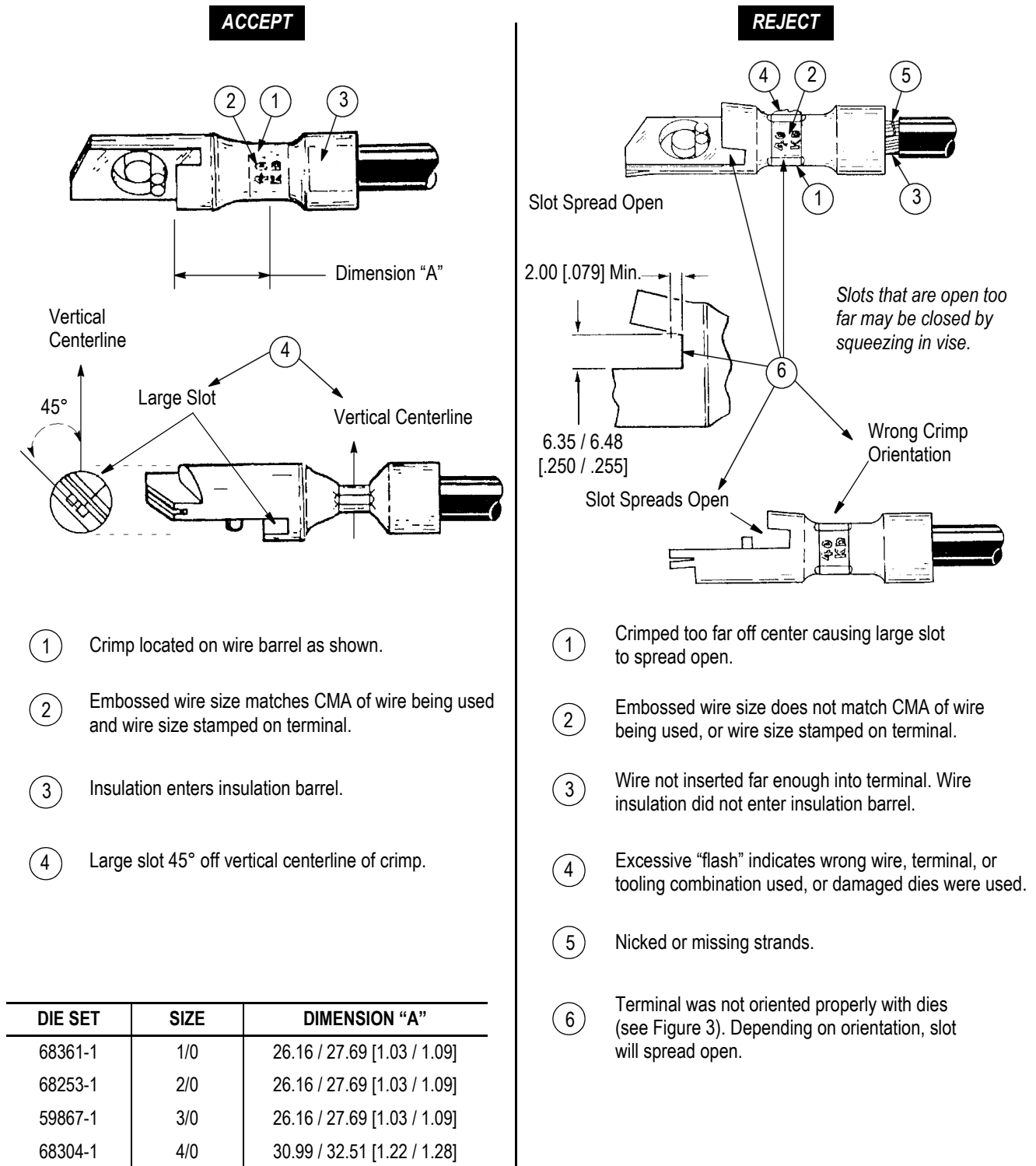
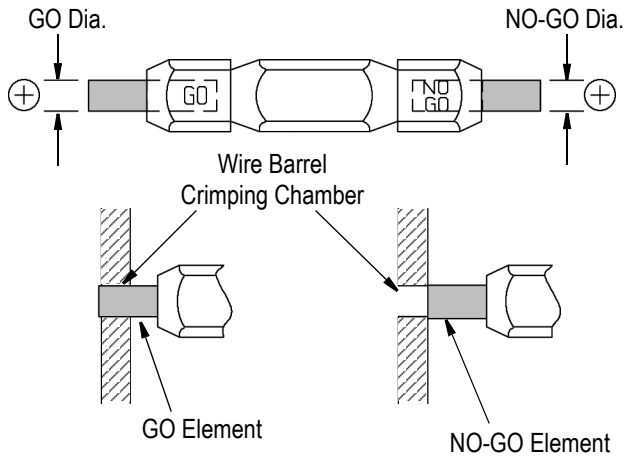

Figure 4

If dies conform to the gage inspection, the crimping chamber is considered dimensionally correct. If correct, the dies should be lubricated with a thin coat of any good SAE 20 motor oil and returned to service.

If not correct, the dies must be returned for further evaluation and repair. Refer to Section 5, REPLACEMENT AND REPAIR.

Suggested Plug Gage Design



CRIMPING DIE NUMBER	GAGE DIMENSION	
	GO (DIA)	NO-GO (DIA)
68361-1	7.544 - 7.551 [.2970 - .2973]	7.795 - 7.798 [.3069 - .3070]
68253-1	8.509 - 8.517 [.3350 - .3353]	8.760 - 8.763 [.3449 - .3450]
59867-1	9.576 - 9.583 [.3770 - .3773]	9.827 - 9.830 [.3869 - .3870]
68304-1	10.490 - 10.498 [.4130 - .4133]	10.742 - 10.744 [.4229 - .4230]

Figure 5

5. REPLACEMENT AND REPAIR

Replacement parts are listed in Figure 7. Parts other than those listed in Figure 7 should be replaced by TE to ensure quality and reliability of the tool. Order replacement parts through your TE representative, or call 1-800-526-5142, or send a facsimile of your purchase order to 1-717-986-7605, or write to:

CUSTOMER SERVICE (038-035)
 TYCO ELECTRONICS CORPORATION
 PO BOX 3608
 HARRISBURG PA 17105-3608

For additional information regarding the use of a plug gage, refer to instruction sheet 408-7424.

For customer repair service, contact a TE representative at 1-800-526-5136.

Dies Positioned At "Gage Dimension"

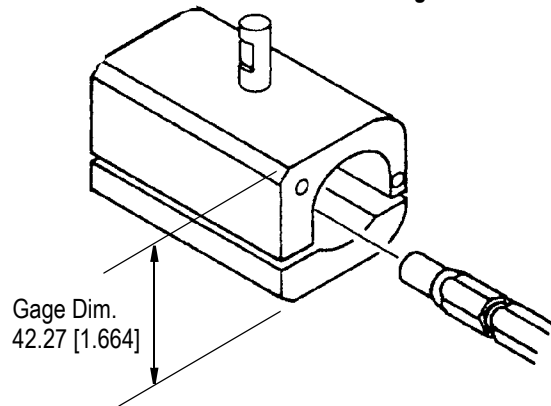
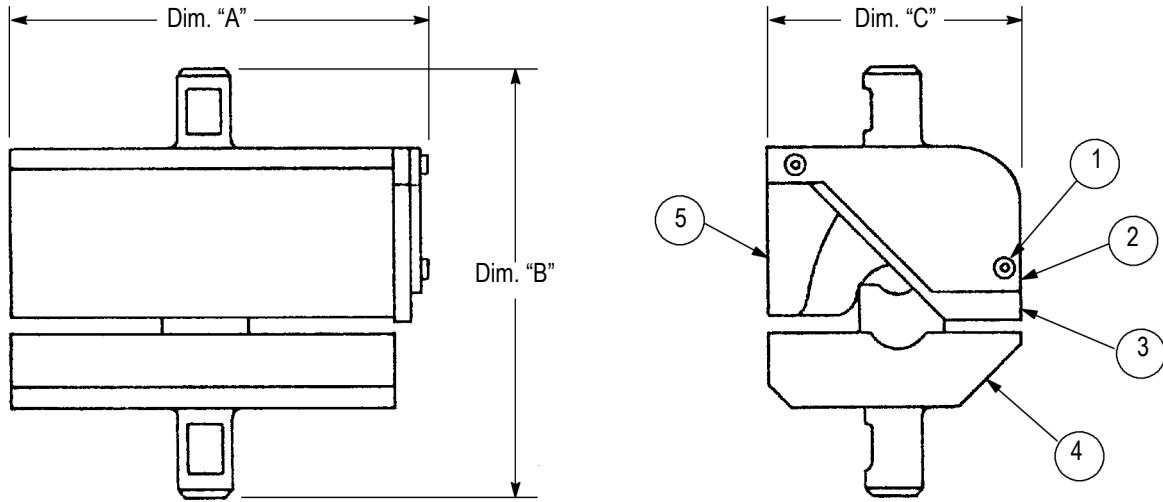

Figure 6

6. REVISION SUMMARY

Since the last revision of this document, the following changes were made:

- Updated document to corporate requirements.



Weight Approximately
794 g [1 lb 12 oz]

ITEM NUMBER	DIE SET NUMBERS AND COMPONENT PART NUMBERS				PART DESCRIPTION	QTY PER ASSY
	68253-1	68304-1	68361-1	59867-1		
1	2-21000-7	2-21000-7	2-21000-7	2-21000-7	SCREW, Skt Hd Cap, 8-32 x .500 L	2
2	308266-1	308266-1	308266-1	308266-1	STOP, Cover	1
3	311476-1	311476-1	311476-1	311476-1	STOP, Locator	1
4	308264-1	308264-2	308264-3	308264-4	DIE, Moving	1
5	308265-1	308265-2	308265-3	308265-4	DIE, Stationary	1

Dim. "A"	61.98 [2.440]	71.50 [2.815]	61.98 [2.440]	61.98 [2.440]
Dim. "B"	73.76 [2.904]	73.76 [2.904]	73.76 [2.904]	73.76 [2.904]
Dim. "C"	41.28 [1.625]	41.28 [1.625]	41.28 [1.625]	41.28 [1.625]

Figure 7

X-ON Electronics

Largest Supplier of Electrical and Electronic Components

Click to view similar products for [Punches & Dies](#) category:

Click to view products by [TE Connectivity](#) manufacturer:

Other Similar products are found below :

[58510-1](#) [63454-1601](#) [63456-0054](#) [63457-3401](#) [64000-0077](#) [64005-0175](#) [730-5/8](#) [734410](#) [PV-670508-001](#) [1322](#) [1338](#) [1338120-1](#) [1338650-1](#)
[1389G6](#) [DIE-R-BNCX-PY](#) [1388G4](#) [1388G6](#) [1389G9](#) [1490593-1](#) [1583609-1](#) [1720](#) [1762951-1](#) [1901268-1](#) [1901269-1](#) [2063500-2](#) [227-](#)
[K1470](#) [19031-0168](#) [CD5-8](#) [R285020212](#) [313336-3](#) [TL-13](#) [TL-16](#) [539756-2](#) [11-24-1109](#) [11-19-3122](#) [539663-1](#) [63446-2241](#) [TL0001](#)
[TL0002](#) [TL-11](#) [TL-18](#) [1762674-1](#) [539740-2](#) [63454-0123](#) [68240-1](#) [68247-1](#) [734252](#) [734596](#) [313183-1](#) [PA2029](#)