

F1A THRU F1M

SURFACE MOUNT FAST RECOVERY RECTIFIERS



VOLTAGE: 50~1000 Volts

CURRENT: 1.0 Amperes

SOD-123FL

Marking and Polarity

FEATURES

- Glass passivated chip junction
- Fast recovery time
- Low Forward Voltage Drop for high efficiency
- Low leakage current for high reliability
- High forward surge capability for high reliability

MECHANICAL DATA

- **Terminals:** Plated Leads Solderable per MIL-STD-202, Method 208
- **Mounting Position:** Any
- **Lead Free:** Lead Free Finish, RoHS Compliant
- **Weight:** App. 0.0161 grams (0.0006 ounce)

TYPICAL APPLICATIONS

- For use in small signal applications

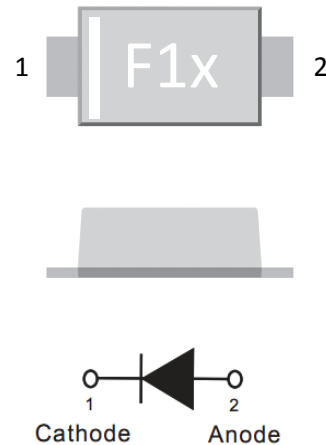

Remark:

- ①. NH=niuhang trademark
- ②. F1x=Modle,x=A,B,D,G,J,K,M
- ③. White band denotes cathode

Maximum Ratings (Ratings at 25°C ambient temperature unless otherwise specified.)

Parameter	Symbol	F1A	F1B	F1D	F1G	F1J	F1K	F1M	Unit
Maximum repetitive peak reverse voltage	V_{RRM}	50	100	200	400	600	800	1000	V
Maximum RMS voltage	V_{RMS}	35	70	140	280	420	560	700	V
Maximum DC blocking voltage	V_{DC}	50	100	200	400	600	800	1000	V
Maximum average forward rectified current(see fig.1)	$I_{F(AV)}$	1.0							A
Peak forward surge current 8.3ms single half sine-wave superimposed on rated load (JEDEC method at rated TL)(see fig.5)	I_{FSM}	30							A
Current Squared Time Per Diode(t<8.3ms)	I^2t	3.74							A ² sec

Electrical Characteristics (Ratings at 25°C ambient temperature unless otherwise specified.)

Parameter	Test Conditions		Symbol	F1A	F1B	F1D	F1G	F1J	F1K	F1M	Unit
Maximum instantaneous forward voltage (see fig.2) (Note 1)	$T_A=25^\circ C$	$I_F=1.0 A$	V_F	1.3							V
Maximum instantaneous reverse current at rated DC blocking voltage (see fig.3)(Note 1)	$T_A=25^\circ C$	$V_R=V_{RRM}$	I_R	5							uA
	$T_A=125^\circ C$	$V_R=80\%*V_{RRM}$		200							
Maximum Reverse Recovery Time	$I_F=0.5A, I_R=1.0A, I_{RR}=0.25A$		T_{RR}	150			250	500		ns	
Typical junction capacitance(see fig.4)	4V,1MHz		C_J	10			6			pF	

Thermal Characteristics (Ratings at 25°C ambient temperature unless otherwise specified)

Parameter	Symbol	F1A	F1B	F1D	F1G	F1J	F1K	F1M	Unit	
Operating junction	T_J	-55 to 150								°C
Storage temperature range	T_{STG}	-55 to 150								
Typical thermal resistance (Note 2)	$R_{\theta JA}$	70							°C/W	
	$R_{\theta JC}$	20								

Note: 1.Pulse width < 300 uS, Duty cycle < 2%

2.P. C. B mounted with 0.1**0.1"(2.54 x 2.54 mm) copper Pad Areas

F1A THRU F1M

SURFACE MOUNT FAST RECOVERY RECTIFIERS



RATING AND CHARACTERISTIC CURVES

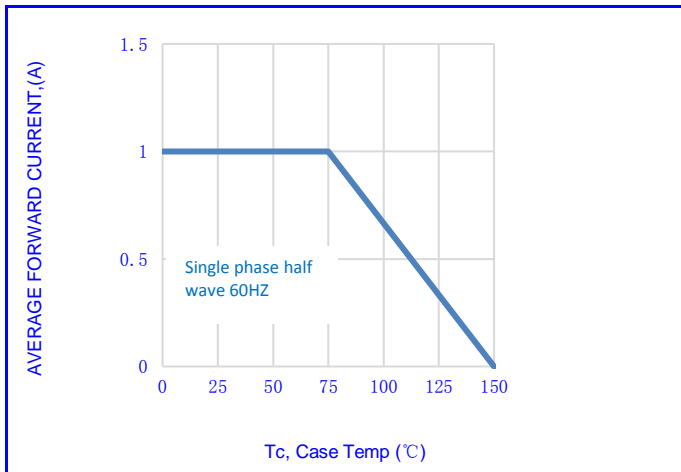

Fig.1- FORWARD CURRENT DERATING CURVE

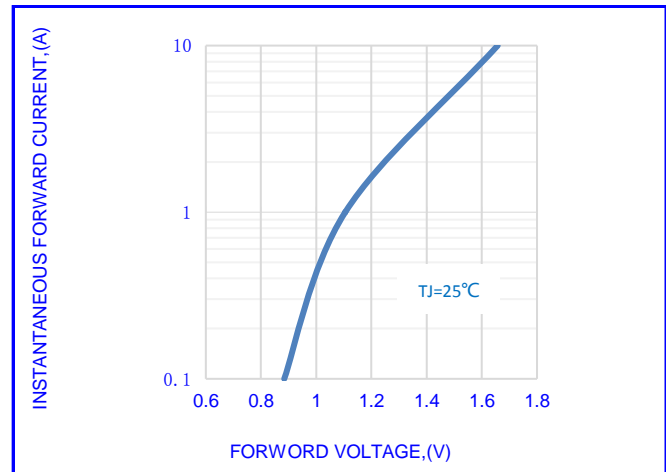

Fig.2-TYPICAL INSTANTANEOUS FORWARD

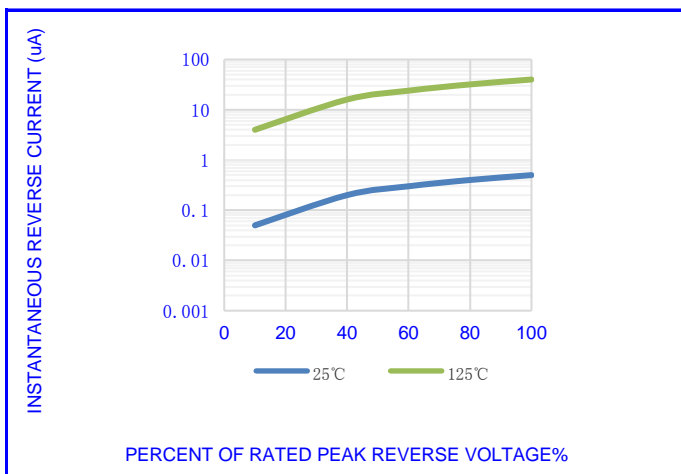

Fig.3-TYPICAL REVERSE CHARACTERISTICS

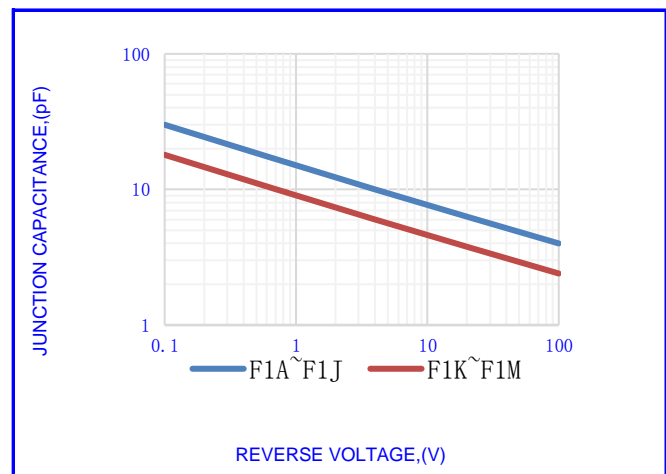

Fig.4- TYPICAL JUNCTION CAPACITANCE

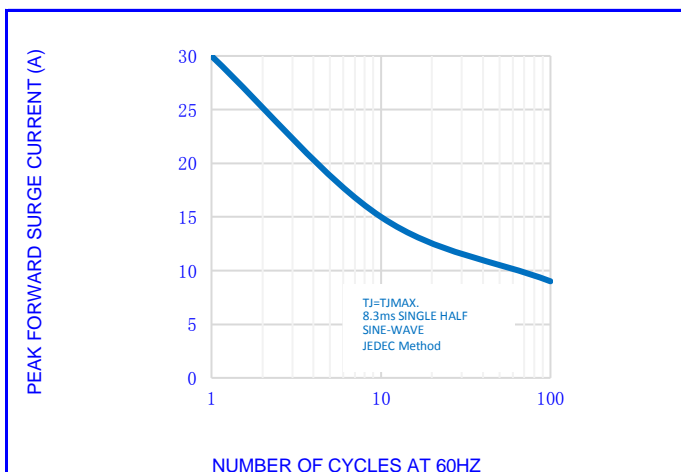

Fig.5-MAX. NON-REPETITIVE SURGE CURRENT

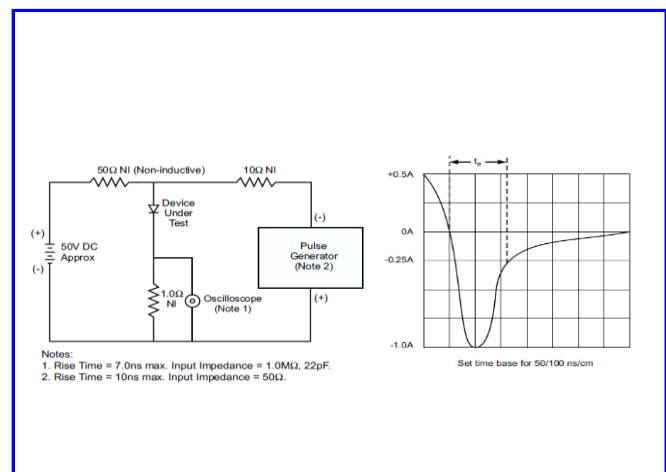

Fig.6-REVERSE RECOVERY TIME CHARACTERISTIC AND TEST CIRCUIT

F1A THRU F1M

SURFACE MOUNT FAST RECOVERY RECTIFIERS



OUTLINE DRAWINGS				SOD-123FL																																																																							
				<table border="1"> <thead> <tr> <th colspan="7">OUTLINE DIMENSIONS</th> </tr> <tr> <th rowspan="2">Dim.</th> <th colspan="3">Milimeters</th> <th colspan="3">Inches</th> </tr> <tr> <th>Min.</th> <th>Typ.</th> <th>Max.</th> <th>Min.</th> <th>Typ.</th> <th>Max.</th> </tr> </thead> <tbody> <tr> <td>A</td> <td>2.650</td> <td>-</td> <td>2.900</td> <td>0.106</td> <td>-</td> <td>0.115</td> </tr> <tr> <td>B</td> <td>3.500</td> <td>-</td> <td>3.700</td> <td>0.137</td> <td>-</td> <td>0.145</td> </tr> <tr> <td>C</td> <td>1.700</td> <td>-</td> <td>1.900</td> <td>0.067</td> <td>-</td> <td>0.075</td> </tr> <tr> <td>D</td> <td>0.900</td> <td>-</td> <td>1.100</td> <td>0.035</td> <td>-</td> <td>0.043</td> </tr> <tr> <td>E</td> <td>0.900</td> <td>-</td> <td>1.100</td> <td>0.035</td> <td>-</td> <td>0.043</td> </tr> <tr> <td>F</td> <td>0.100</td> <td>-</td> <td>0.250</td> <td>0.004</td> <td>-</td> <td>0.100</td> </tr> <tr> <td>G</td> <td>0.450</td> <td>-</td> <td>0.750</td> <td>0.017</td> <td>-</td> <td>0.030</td> </tr> </tbody> </table>			OUTLINE DIMENSIONS							Dim.	Milimeters			Inches			Min.	Typ.	Max.	Min.	Typ.	Max.	A	2.650	-	2.900	0.106	-	0.115	B	3.500	-	3.700	0.137	-	0.145	C	1.700	-	1.900	0.067	-	0.075	D	0.900	-	1.100	0.035	-	0.043	E	0.900	-	1.100	0.035	-	0.043	F	0.100	-	0.250	0.004	-	0.100	G	0.450	-	0.750	0.017	-	0.030
OUTLINE DIMENSIONS																																																																											
Dim.	Milimeters			Inches																																																																							
	Min.	Typ.	Max.	Min.	Typ.	Max.																																																																					
A	2.650	-	2.900	0.106	-	0.115																																																																					
B	3.500	-	3.700	0.137	-	0.145																																																																					
C	1.700	-	1.900	0.067	-	0.075																																																																					
D	0.900	-	1.100	0.035	-	0.043																																																																					
E	0.900	-	1.100	0.035	-	0.043																																																																					
F	0.100	-	0.250	0.004	-	0.100																																																																					
G	0.450	-	0.750	0.017	-	0.030																																																																					
RECOMMENDED LAYOUT DRAWINGS				SOD-123FL																																																																							
				<table border="1"> <thead> <tr> <th colspan="7">RECOMMENDED MOUNTING PAD DIMENSIONS</th> </tr> <tr> <th rowspan="2">Dim.</th> <th colspan="3">Milimeters</th> <th colspan="3">Inches</th> </tr> <tr> <th>Min.</th> <th>Typ.</th> <th>Max.</th> <th>Min.</th> <th>Typ.</th> <th>Max.</th> </tr> </thead> <tbody> <tr> <td>A</td> <td>-</td> <td>4.250</td> <td>-</td> <td>-</td> <td>0.167</td> <td>-</td> </tr> <tr> <td>B</td> <td>-</td> <td>1.220</td> <td>-</td> <td>-</td> <td>0.048</td> <td>-</td> </tr> <tr> <td>C</td> <td>-</td> <td>2.700</td> <td>-</td> <td>-</td> <td>0.106</td> <td>-</td> </tr> <tr> <td>D</td> <td>-</td> <td>0.780</td> <td>-</td> <td>-</td> <td>0.031</td> <td>-</td> </tr> </tbody> </table>			RECOMMENDED MOUNTING PAD DIMENSIONS							Dim.	Milimeters			Inches			Min.	Typ.	Max.	Min.	Typ.	Max.	A	-	4.250	-	-	0.167	-	B	-	1.220	-	-	0.048	-	C	-	2.700	-	-	0.106	-	D	-	0.780	-	-	0.031	-																					
RECOMMENDED MOUNTING PAD DIMENSIONS																																																																											
Dim.	Milimeters			Inches																																																																							
	Min.	Typ.	Max.	Min.	Typ.	Max.																																																																					
A	-	4.250	-	-	0.167	-																																																																					
B	-	1.220	-	-	0.048	-																																																																					
C	-	2.700	-	-	0.106	-																																																																					
D	-	0.780	-	-	0.031	-																																																																					
PACKING INFORMATION				SOD-123FL																																																																							
Package Method	Reel Size (mm)	Quantity (pcs/reel)	Inner Box Size LxWxH(mm)	Quantity (pcs/Inner Box)	Carton Size LxWxH(mm)	Quantity (pcs/carton)																																																																					
Tape Reel	Φ180	3000	185x185x90	21000	400x400x300	252000																																																																					

F1A THRU F1M

SURFACE MOUNT FAST RECOVERY RECTIFIERS



Recommended wave soldering condition

Product	Peak Temperature	Soldering Time
Pb-free devices	260 +0/-5 °C	5 +1/-1 seconds

Recommended temperature profile for IR reflow

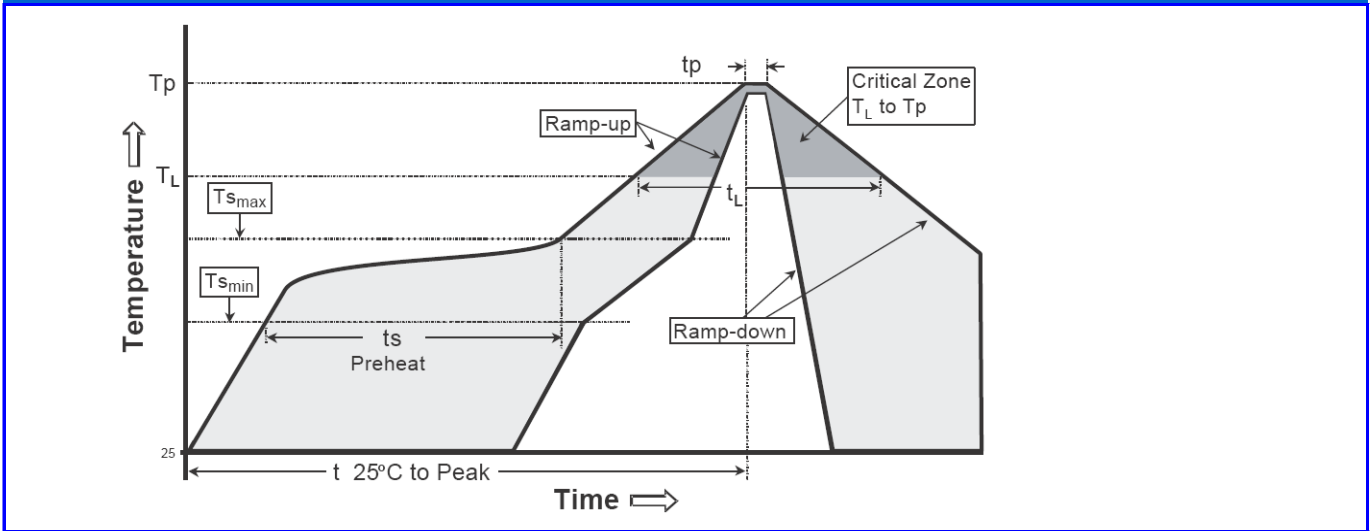

Profile feature	Sn-Pb eutectic Assembly	Pb-free Assembly
Average ramp-up rate (Tsmmax to Tp)	3°C/second max.	3°C/second max.
Preheat -Temperature Min(TS min) -Temperature Max(TS max) -Time(ts min to ts max)	100°C 150°C 60-120 seconds	150°C 200°C 60-180 seconds
Time maintained above: -Temperature (TL) - Time (tL)	183°C 60-150 seconds	217°C 60-150 seconds
Peak Temperature(TP)	240 +0/-5 °C	260 +0/-5 °C
Time within 5°C of actual peak temperature(tp)	10-30 seconds	20-40 seconds
Ramp down rate	6°C/second max.	6°C/second max.
Time 25 °C to peak temperature	6 minutes max.	8 minutes max.

Note : All temperatures refer to topside of the package, measured on the package body surface.

F1A THRU F1M

SURFACE MOUNT FAST RECOVERY RECTIFIERS



Disclaimer

- Reproducing and modifying information of the document is prohibited without permission from niuhang Electronics co., LTD
- Niuhan Electronics co., LTD. reserves the rights to make changes of the content herein the document anytime without notification.
- Niuhan Electronics co., LTD. disclaims any and all liability arising out of the application or use of any product including damages incidentally and consequentially occurred.
- Niuhan Electronics co., LTD. does not assume any and all implied warranties, including warranties of fitness for particular purpose, non-infringement and merchantability.
- Applications shown on the herein document are examples of standard use and operation. Customers are responsible in comprehending the suitable use in particular applications. Niuhan Electronics co., LTD. makes no representation or warranty that such applications will be suitable for the specified use without further testing or modification.
- The products shown herein are not designed and authorized for equipments requiring high level of reliability or relating to human life and for any applications concerning life-saving or life-sustaining, such as medical instruments, transportation equipment, aerospace machinery et cetera. Customers using or selling these products for use in such applications do so at their own risk and agree to fully indemnify Niuhan Electronics co., LTD. for any damages resulting from such improper use or sale.
- When the appearance of the product and chip size does not change, in order to product the customer quality, change the internal structure and the production process Niuhan can not notify

X-ON Electronics

Largest Supplier of Electrical and Electronic Components

Click to view similar products for [Rectifiers](#) category:

Click to view products by [NH manufacturer](#):

Other Similar products are found below :

[70HFR40](#) [FR105 R0](#) [RL252-TP](#) [1N5397](#) [1N4005-TR](#) [1N4007-BP](#) [UFS120Je3/TR13](#) [20ETS12S](#) [RRE02VS6SGTR](#) [MS306](#) [A1N5404G-G](#)
[CRF02\(T5L,TEMQ\)](#) [ACGRB207-HF](#) [CLH07\(TE16L,Q\)](#) [CLH03\(TE16L,Q\)](#) [1N5395-TP](#) [UES1302](#) [ACGRC307-HF](#) [ACEFC304-HF](#) [DZ-](#)
[1380](#) [85HFR60](#) [40HFR60](#) [70HF120](#) [85HFR80](#) [SCF7500](#) [SM100](#) [ACGRA4001-HF](#) [SKN70/08](#) [NTE5819](#) [NTE5827](#) [NTE5828](#) [NTE5911](#)
[NTE5915](#) [NTE6104](#) [NTE6163](#) [NTE6164](#) [NTE6165](#) [NTE6364](#) [TSD3G](#) [SET130312](#) [NRVUS110VT3G](#) [UES1106](#) [UES1306](#)
[NRVUS240VT3G](#) [D5FE60-5063](#) [R4000GPS-TP](#) [D4015L56TP](#) [UES1306HR2](#) [FX20K120](#) [D20XB60-7101](#)