

NPS10N65F

650V N-Channel Enhancement Mode Power MOSFET



VOLTAGE:	650 Volts	CURRENT:	10.0 Amperes	TO-220F	Marking and Polarity
-----------------	-----------	-----------------	--------------	----------------	-----------------------------

FEATURES

- Low RDS(ON)
- Ultra Low Gate Charge
- RoHS Compliant
- 100% UIS and RG Tested

TYPICAL APPLICATIONS

- Adapter,PC,PD,Charger,LED Driver
- Switched mode power supplies(SMPS)
- Uninterruptible Power Supply (UPS)

PRODUCT SUMMARY

VDS@T _J MAX.	650	V
ID	10.0	A
RDS(ON) ,Typ.@10V	0.84	Ω

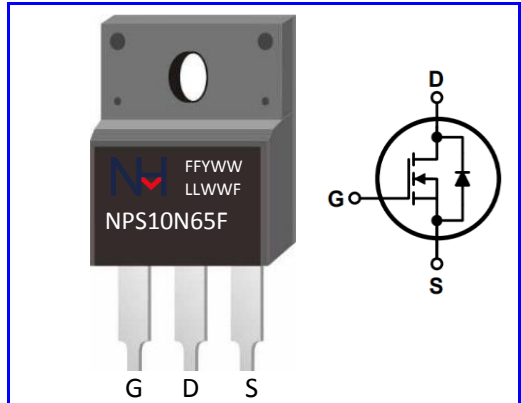

Remark:

- NH=niuhang trademark;
- FF=Product line code,According to actual changes
YWW=Data code,According to actual changes
LLWWF=Internal code,According to actual changes
- NPS10N65F=Module.

Absolute Maximum Ratings (Ratings at 25°C ambient temperature unless otherwise specified)

Parameter	Test Conditions	Symbol	Ratings	Unit
Drain-Source Voltage		V _{DS}	650	V
Gate-Source Voltage		V _{GS}	±30	V
Continuous Drain Current (Note 1)	Ta= 25 °C Ta= 100 °C	I _D	10 6.4	A
Drain Current-Pulsed (Note 1)	T _J < 150 °C	I _{DM}	40	A
Maximum Power Dissipation	Ta= 25 °C	P _D	42	W
Power Dissipation Derating Factor above 25°C	Ta= 100 °C		17	
Derating Factor		D _F	0.33	W/°C
Junction Temperature		T _J	-55 to 150	°C
Storage temperature range		T _{STD}	-55 to 150	°C
Avalanche Current,Single pulse	L= 10 mH	I _{AS}	10	A
Single Pulse Avalanche Energy	L= 10 mH,VDD=15V IAS= 10 A,RG=25Ω Starting T _J =25°C	E _{AS}	500	mJ

Thermal Characteristics (Ratings at 25°C ambient temperature unless otherwise specified)

Parameter	Test Conditions	Symbol	Typ.	Unit
Thermal Resistance Junction to Ambient(Note 2)	1.still air environment with TA =25° C.	R _{θJA}	62.5	°C/W
Thermal Resistance Junction-Case(Note 2)	2.device mounted on 1 in ² FR-4 board with 2oz	R _{θJC}	3.0	

Notes:

- Repetitive Rating : Pulse width limited by maximum junction temperature
- The value of R_{θJA} is measured with the device mounted on 1in2 FR-4 board with 2oz. Copper, in a still air environment with TA =25° C.
The value in any given application depends on the user's specific board design.This transistor is sensitive to electrostatic discharge and should be handled with care.



NPS10N65F

650V N-Channel Enhancement Mode Power MOSFET



Electrical Characteristics (Ratings at 25°C ambient temperature unless otherwise specified)

Parameter	Test Conditions	Symbol	Min.	Typ.	Max.	Unit
Static off Characteristics						
Drain-Source Breakdown Voltage	VGS=0V, ID=250uA	BV_{DSS}	650	-	-	V
Bvdss Temperature Coefficient	ID=250uA, Reference 25°C	$\Delta BV_{DSS}/\Delta T_J$	-	0.67	-	V/°C
Drain-Source Leakage Current	VDS= 650 V, VGS=0V	I_{DSS}	-	-	1	uA
Gate-Body Leakage Current	VGS= ±30 V, VDS=0V	I_{GSS}	-	-	±100	nA
Static on Characteristics						
Gate Threshold Voltage	VGS= VDS ID=250uA	$V_{GS(TH)}$	2.0	3.0	4.0	V
Drain-Source On Resistance	ID= 5 A, VGS=10V	$R_{DS(ON)}$	-	0.84	1.0	Ω
Dynamic Characteristics						
Input Capacitance	VDS= 25 V	C_{iss}	-	1609	-	pF
Output Capacitance	VGS= 0 V	C_{oss}	-	136	-	pF
Reverse Transfer Capacitance	F= 1 MHz	C_{rss}	-	7.5	-	pF
Switching Paramters						
Turn-On Delay Time	VDS= 325 V	$t_{d(on)}$	-	20	-	ns
Turn-On Rise Time	ID= 10 A	t_r	-	30	-	ns
Turn-Off Delay Time	VGS= 10 V	$t_{d(off)}$	-	90	-	ns
Turn-Off Rise Time	RG= 25 Ω	t_f	-	40	-	ns
Total Gate Charge	VDS= 520 V	Q_g	-	32	-	nC
Gate-Source Charge	ID= 10 A	Q_{gs}	-	8	-	nC
Gate-Drain Charge	VGS= 10 V	Q_{gd}	-	12	-	nC
Drain-Source Diode Characteristics and Maximum Ratings						
Max. Diode Forward Current		I_S	-	-	10	A
Max. Pulsed Forward Current		I_{SM}	-	-	40	A
Diode Forward Voltage	ID= 10 A, VGS=0V	V_{SD}	-	0.85	1.4	V
Reverse Recovery Time	ID= 10 A, VGS=0V	t_{rr}	-	385	-	ns
Reverse Recovery Charge	di/dt= 100 A/us	Q_{rr}	-	3	-	μC

NPS10N65F

650V N-Channel Enhancement Mode Power MOSFET



Typical Characteristics Curves

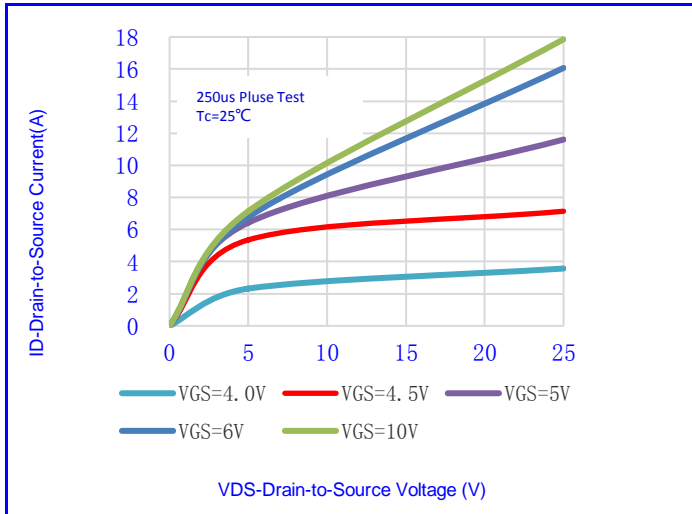

Fig.1-Output Characteristics

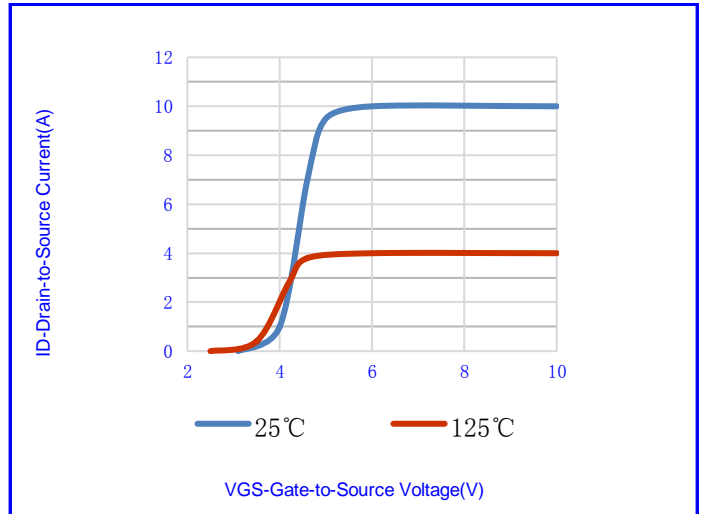

Fig.2- Transfer Characteristics

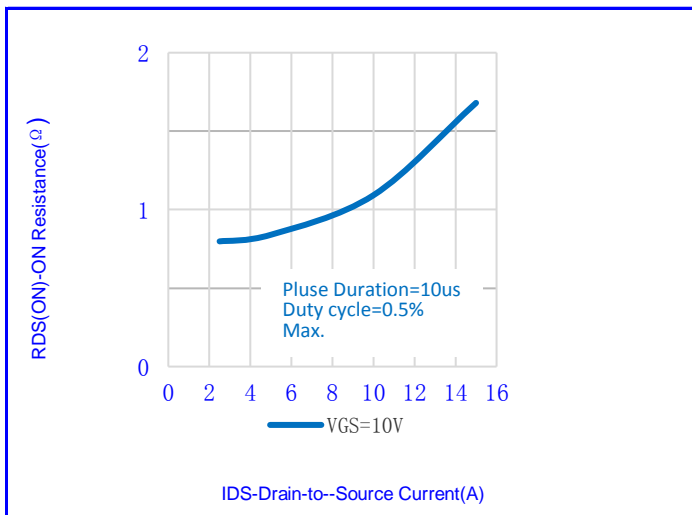

Fig.3- On Resistance vs. Drain Current

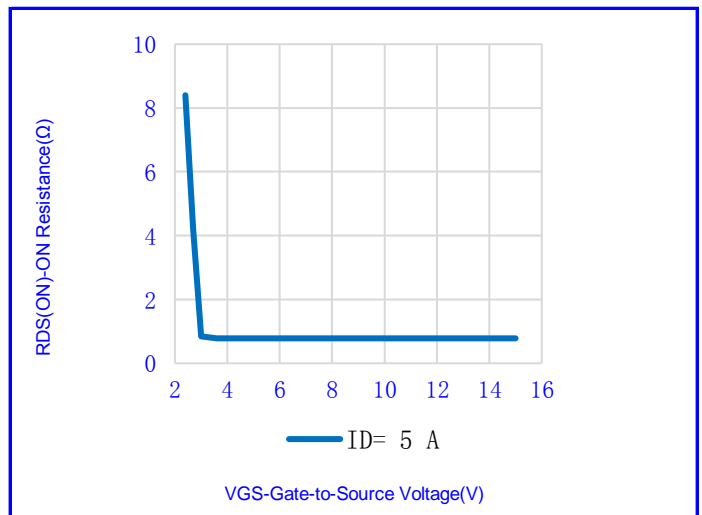

Fig.4- On Resistance vs. Gate Source Voltage

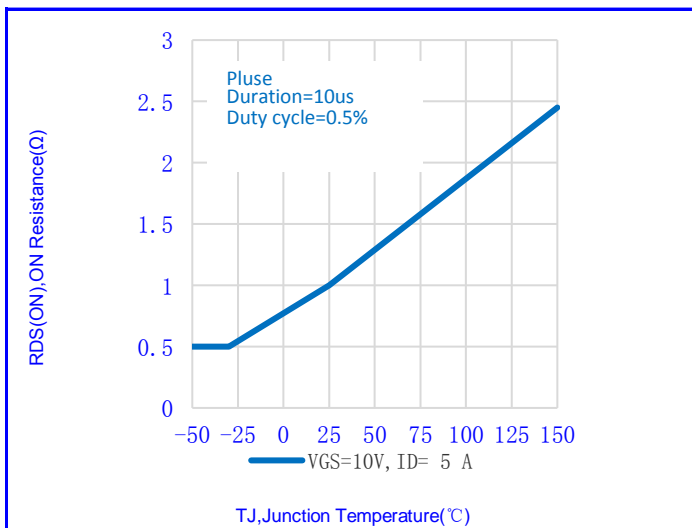

Fig.5- On Resistance vs. Junction Temperature

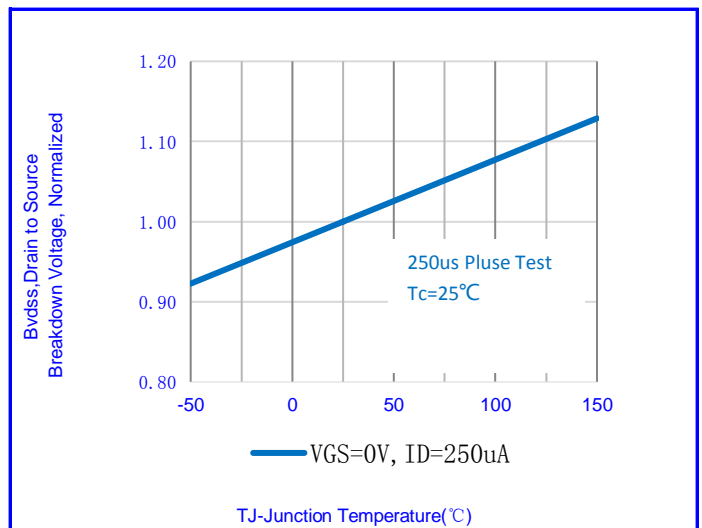

Fig.6- Breakdown Voltage vs. Junction Temperature

NPS10N65F

650V N-Channel Enhancement Mode Power MOSFET



Typical Characteristics Curves

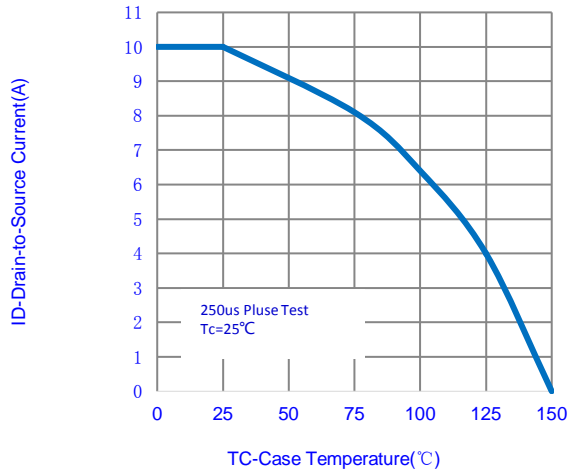

Fig.7-Maximum Continuous Drain Current vs. Case Temperature

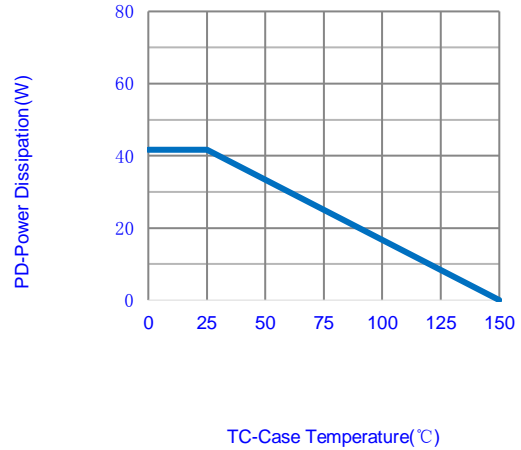

Fig.8-Maximum Power Dissipation vs. Case Temperature

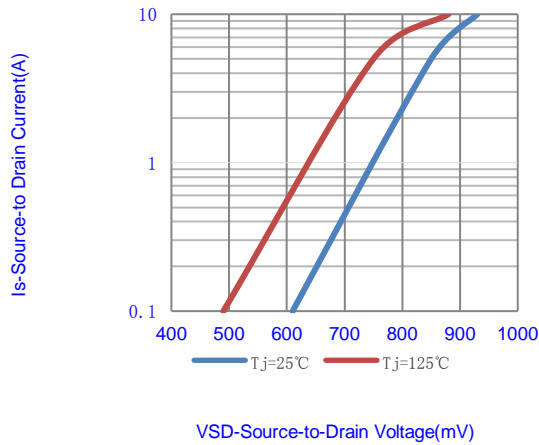

Fig.9- Source-Drain Diode Forward Voltage

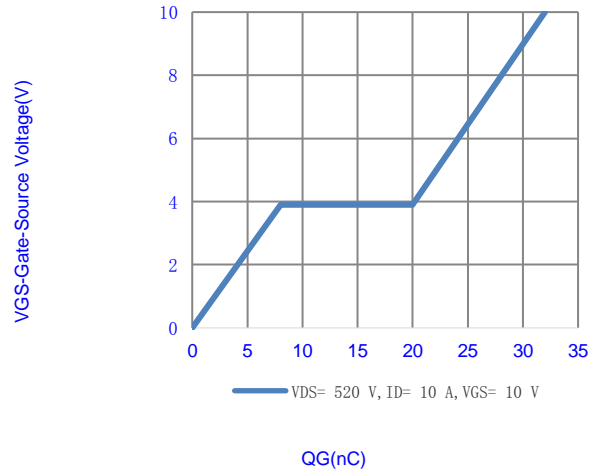

Fig.10-Gate Charge Waveform

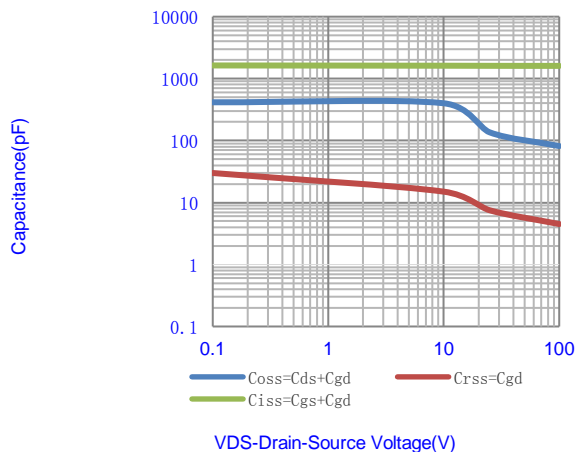

Fig.11- Gate-Source Voltage-VGS(V)

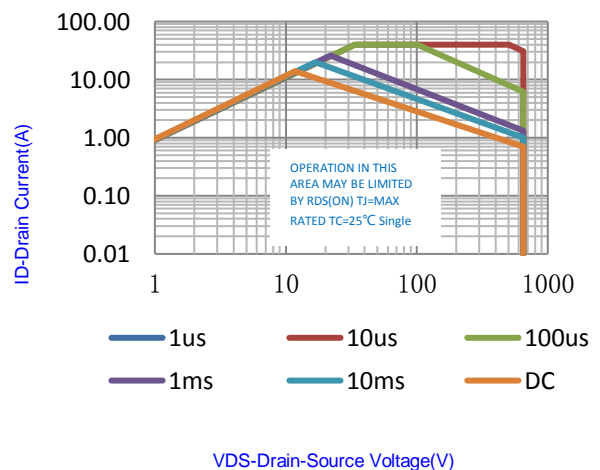

Fig.12-Maximum Safe Operating Area(SOA)

NPS10N65F

650V N-Channel Enhancement Mode Power MOSFET



Typical Characteristics Curves

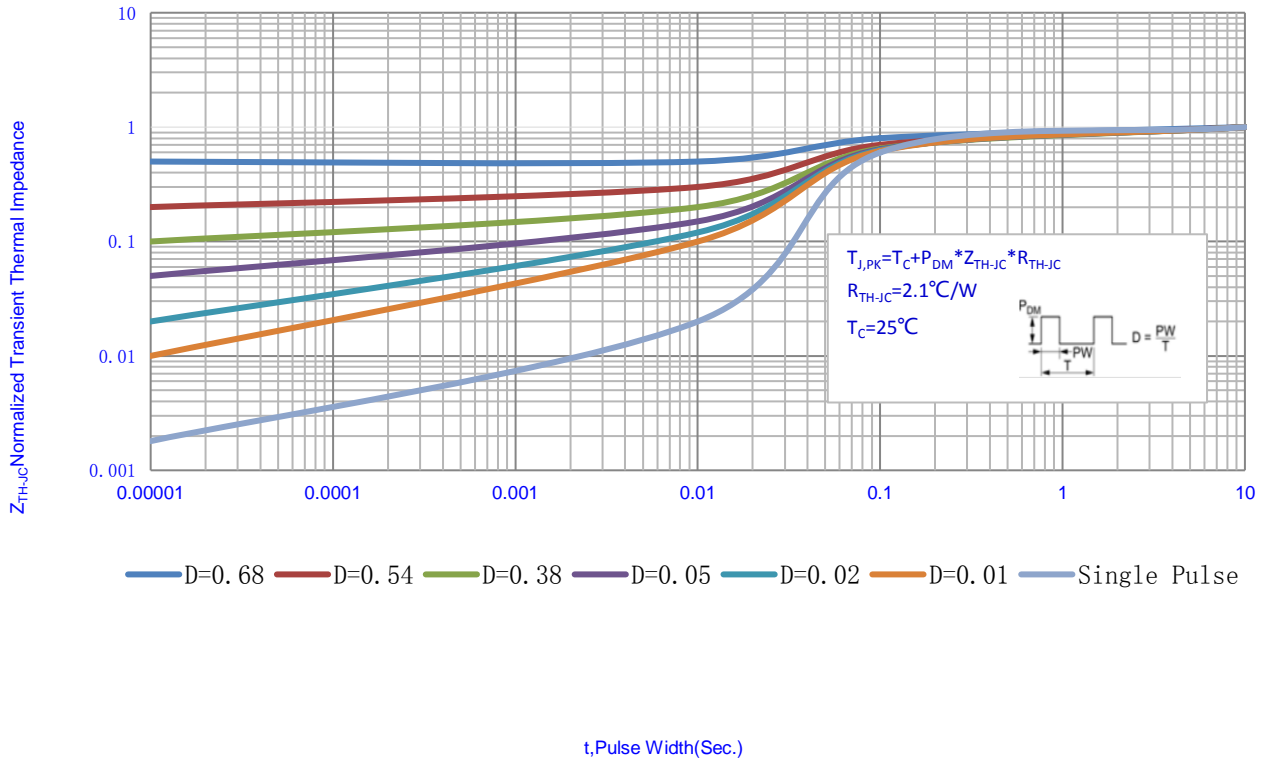

Fig.13- Normalized Transient Thermal Impedance vs. Pulse Width

Test Circuit & Waveform

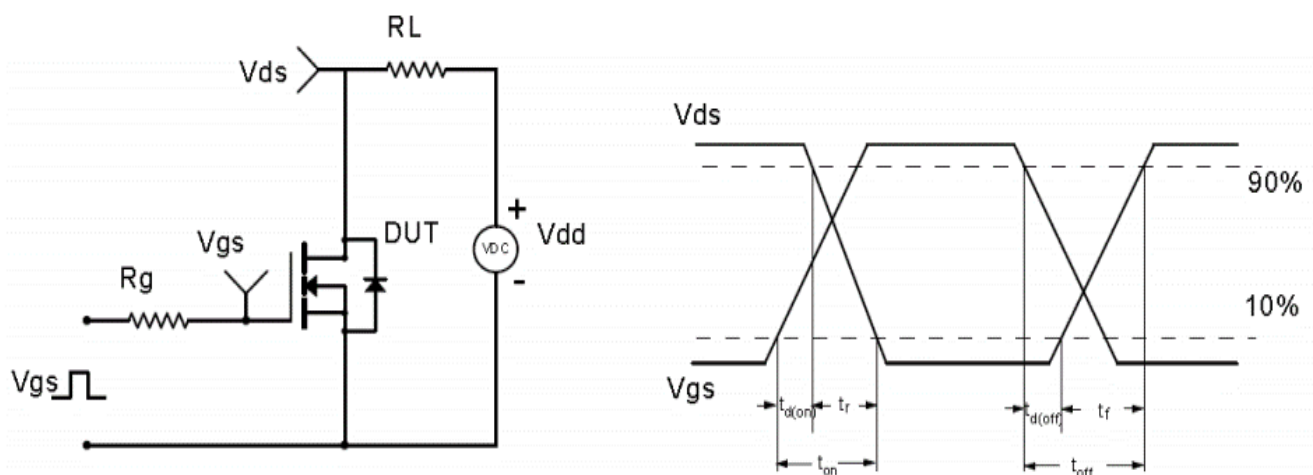

Fig.14- Resistive Switching Test Circuit & Waveform

NPS10N65F

650V N-Channel Enhancement Mode Power MOSFET



Test Circuit & Waveform

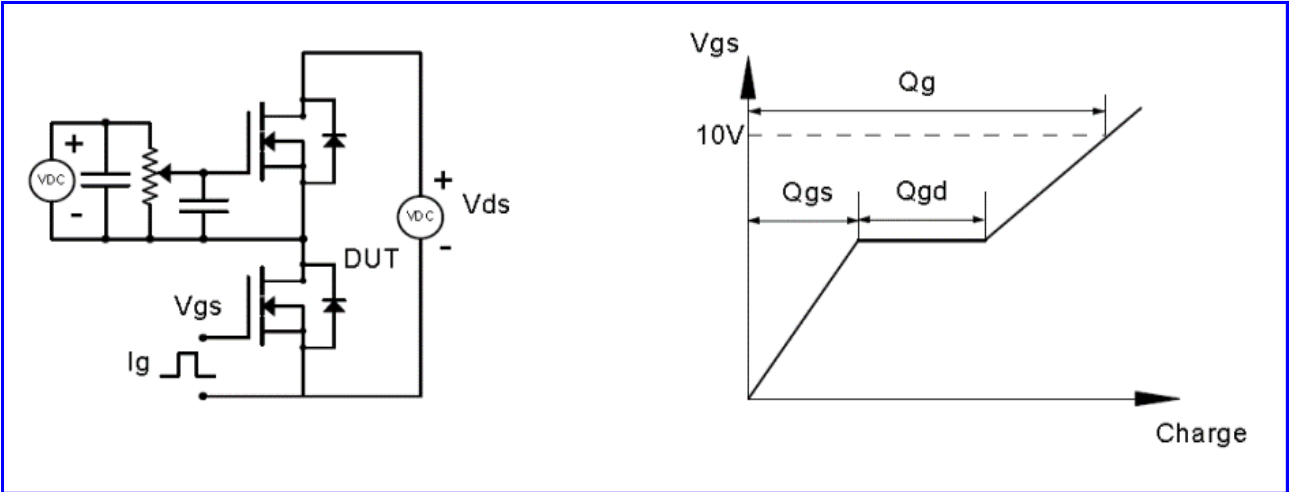

Fig.15- Gate Charge Test Circuit & Waveform

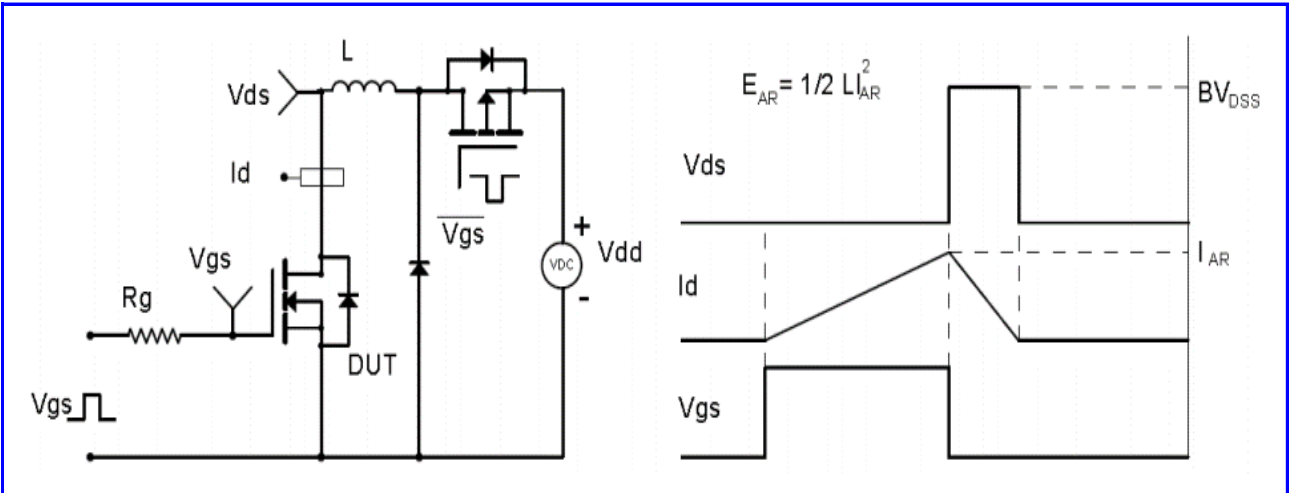

Fig.16- EAS Test Circuit & Waveform

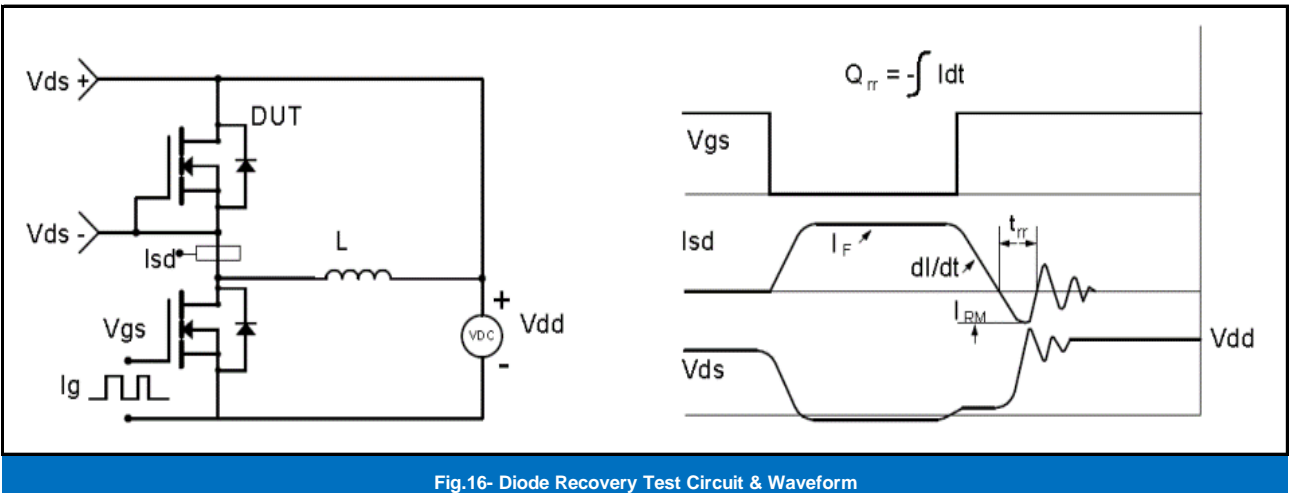

Fig.16- Diode Recovery Test Circuit & Waveform

NPS10N65F

650V N-Channel Enhancement Mode Power MOSFET



OUTLINE DRAWINGS

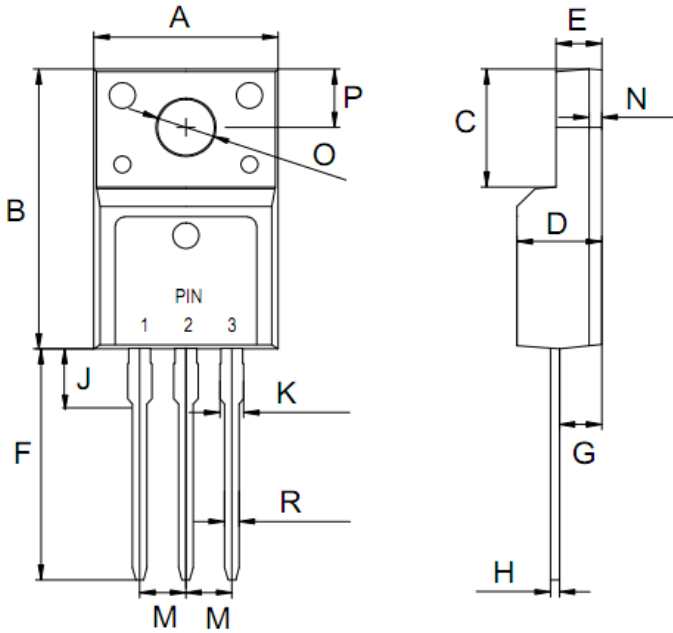

TO-220F

OUTLINE DIMENSIONS						
Dim.	Millimeters			Inches		
	Min.	Typ.	Max.	Min.	Typ.	Max.
A	10.00	-	10.50	0.39	-	0.41
B	15.40	-	16.20	0.61	-	0.64
C	6.48	-	6.88	0.26	-	0.27
D	4.50	-	4.90	0.18	-	0.19
E	2.35	-	2.75	0.09	-	0.11
F	12.50	-	-	0.49	-	-
G	2.40	-	3.00	0.09	-	0.12
H	0.40	-	0.60	0.02	-	0.02
J	2.20	-	4.20	0.09	-	0.17
M	2.40	-	2.70	0.09	-	0.11
N	0.80	-	1.10	0.03	-	0.04
K	1.20	-	1.50	0.05	-	0.06
R	0.60	-	1.00	0.02	-	0.04
O	3.10	-	3.70	0.12	-	0.15
P	3.00	-	4.00	0.12	-	0.16

PACKING INFORMATION

TO-220F

Package Method	Reel Size (mm)	Quantity (pcs/reel)	Inner Box Size LxWxH(mm)	Quantity (pcs/Inner Box)	Outer Carton Size LxWxH(mm)	Quantity (pcs/carton)
Tape Reel	Φ330	2500	340x340x50	5000	360x360x260	25000

NPS10N65F

650V N-Channel Enhancement Mode Power MOSFET



Recommended wave soldering condition

Product	Peak Temperature	Soldering Time
Pb-free devices	260 +0/-5 °C	5 +1/-1 seconds

Recommended temperature profile for IR reflow

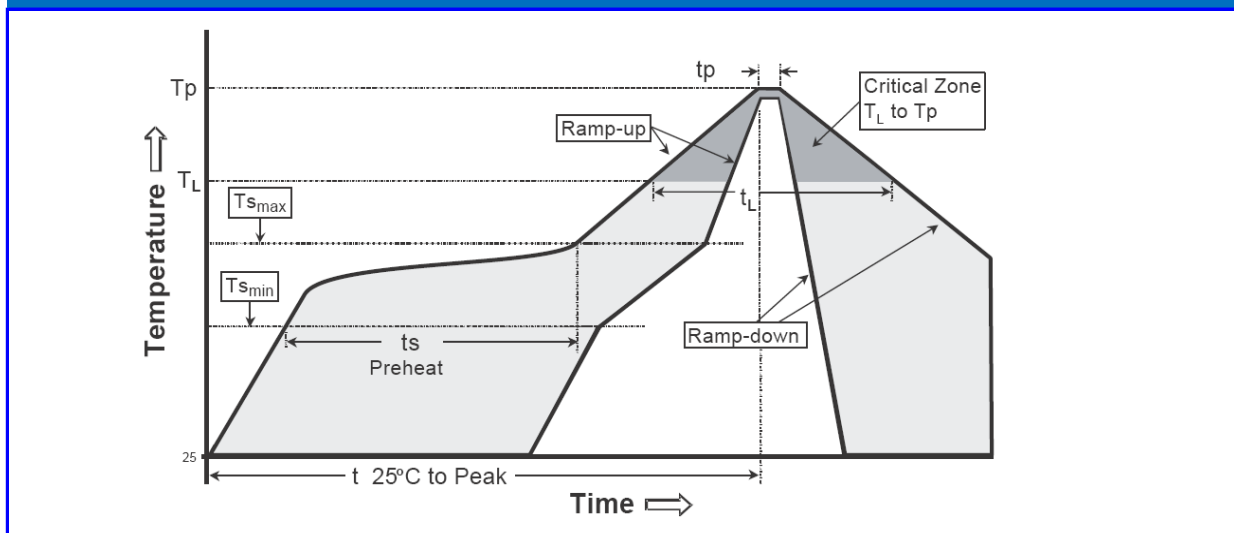

Profile feature	Sn-Pb eutectic Assembly	Pb-free Assembly
Average ramp-up rate (Tsmax to Tp)	3°C/second max.	3°C/second max.
Preheat -Temperature Min(TS min) -Temperature Max(TS max) -Time(ts min to ts max)	100°C 150°C 60-120 seconds	150°C 200°C 60-180 seconds
Time maintained above: -Temperature (TL) - Time (tL)	183°C 60-150 seconds	217°C 60-150 seconds
Peak Temperature(TP)	240 +0/-5 °C	260 +0/-5 °C
Time within 5°C of actual peak temperature(tp)	10-30 seconds	20-40 seconds
Ramp down rate	6°C/second max.	6°C/second max.
Time 25 °C to peak temperature	6 minutes max.	8 minutes max.

Note : All temperatures refer to topside of the package, measured on the package body surface.

NPS10N65F

650V N-Channel Enhancement Mode Power MOSFET



Disclaimer

- Reproducing and modifying information of the document is prohibited without permission from niuhang Electronics co., LTD
- Niuhan Electronics co., LTD. reserves the rights to make changes of the content herein the document anytime without notification.
- Niuhan Electronics co., LTD. disclaims any and all liability arising out of the application or use of any product including damages incidentally and consequentially occurred.
- Niuhan Electronics co., LTD. does not assume any and all implied warranties, including warranties of fitness for particular purpose, non-infringement and merchantability.
- Applications shown on the herein document are examples of standard use and operation. Customers are responsible in comprehending the suitable use in particular applications. Niuhan Electronics co., LTD. makes no representation or warranty that such applications will be suitable for the specified use without further testing or modification.
- The products shown herein are not designed and authorized for equipments requiring high level of reliability or relating to human life and for any applications concerning life-saving or life-sustaining, such as medical instruments, transportation equipment, aerospace machinery et cetera. Customers using or selling these products for use in such applications do so at their own risk and agree to fully indemnify Niuhan Electronics co., LTD. for any damages resulting from such improper use or sale.
- When the appearance of the product and chip size does not change, in order to product the customer quality, change the internal structure and the production process Niuhan can not notify

X-ON Electronics

Largest Supplier of Electrical and Electronic Components

Click to view similar products for [MOSFET](#) category:

Click to view products by [NH](#) manufacturer:

Other Similar products are found below :

[IRFD120](#) [JANTX2N5237](#) [BUK455-60A/B](#) [MIC4420CM-TR](#) [VN1206L](#) [NDP4060](#) [SI4482DY](#) [IPS70R2K0CEAKMA1](#) [SQD23N06-31L-GE3](#)
[TK16J60W,S1VQ\(O](#) [2SK2614\(TE16L1,Q\)](#) [DMN1017UCP3-7](#) [DMN1053UCP4-7](#) [SQJ469EP-T1-GE3](#) [NTE2384](#) [DMC2700UDMQ-7](#)
[DMN2080UCB4-7](#) [DMN61D9UWQ-13](#) [US6M2GTR](#) [DMN31D5UDJ-7](#) [DMP22D4UFO-7B](#) [DMN1006UCA6-7](#) [DMN16M9UCA6-7](#)
[STF5N65M6](#) [IRF40H233XTMA1](#) [STU5N65M6](#) [DMN6022SSD-13](#) [DMN13M9UCA6-7](#) [DMTH10H4M6SPS-13](#) [DMN2990UFB-7B](#)
[IPB80P04P405ATMA2](#) [2N7002W-G](#) [MCAC30N06Y-TP](#) [MCQ7328-TP](#) [BXP7N65D](#) [BXP4N65F](#) [AOL1454G](#) [WMJ80N60C4](#) [BXP2N20L](#)
[BXP2N65D](#) [BXT1150N10J](#) [BXT1700P06M](#) [TSM60NB380CP](#) [ROG](#) [RQ7L055BGTCR](#) [DMNH15H110SK3-13](#) [SLF10N65ABV2](#)
[BSO203SP](#) [BSO211P](#) [IPA60R230P6](#) [IPA60R460CE](#)