

**SF16025CT,SF16025FCT**  
SUPER FAST RECOVERY RECTIFIERS



**VOLTAGE:** 250 Volts

**CURRENT:** 16.0 Ampers

**Marking and Polarity**

**FEATURES**

- Glass passivated chip junction
- Ultrafast reverse recovery time
- Low leakage current for high reliability
- Low forward voltage drop for high efficiency
- High surge capability for high reliability
- High temperature soldering guaranteed:260°C max./10 seconds at terminals

**MECHANICAL DATA**

- **Case:** JEDEC TO-220AB、TO-220F  
Molding compound meets UL94V-0 flammability rating
- **Terminals:** Lead solderable per J-STD-002 and JESD22-B102
- **Polarity:** As marked
- **Mounting Torque:** 10 in-lbs maximum

**TYPICAL APPLICATIONS**

- For use in switching power supplies ,high frequency inverters and LED Driver applications

**TO-220AB  
SF16025CT**

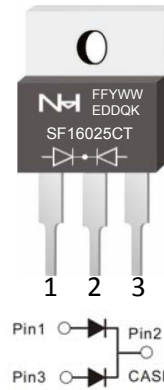

**TO-220F  
SF16025FCT**



**Remark:**

- ①. NH=niuhang trademark;
- ②. FF=Product line code,According to actual changes  
YWW=Date code,According to actual changes  
EDDQK=Inernal code,According to actual changes
- ③. SF16025CT/FCT=Modle.

**Maximum Ratings (Ratings at 25°C ambient temperature unless otherwise specified )**

Parameter	Symbol	SF16025CT,SF16025FCT	Unit
Maximum repetitive peak reverse voltage	$V_{RRM}$	250	V
Maximum average forward rectified current(see fig.1)	$I_{F(AV)}$	16	A
Peak forward surge current 8.3ms single half sine-wave superimposed on rated load (JEDEC method at rated TL)	$I_{FSM}$	200	A
Peak repetitive reverse current per diode at $t_p=2\mu s$ 1KHz	$I_{RRM}$	5	$\mu A$
Isolation voltage(TO-220F only)from terminals to heatsink $t=1$ min	$V_{AC}$	1500	V
Maximum Mounting torque, M3 screw	$T_{MM}$	1.1	N.m

**Electrical Characteristcs (Ratings at 25°C ambient temperature unless otherwise specified )**

Parameter	Test Conditions		Symbol	SF16025CT,SF16025FCT			Unit
				Min.	Typ.	Max.	
Instaneous forward voltage per diode (note1)	$T_A=25^\circ C$	$I_F= 8 A$	$V_F$	--	1.35	1.75	V
	$T_A=125^\circ C$			--	1.25	1.70	
Reverse current per diode (note2)	$T_A=25^\circ C$	$V_R= 250 V$	$I_R$	--	--	5	$\mu A$
	$T_A=125^\circ C$			--	--	100	mA
Maximum Reverse Recovery Time	$I_F=0.5A, I_R=1.0A, I_{RR}=0.25A$		$T_{RR}$	--	35	50	ns
Typical junction capacitance	4V,1MHz		$C_J$	--	40		pF

**Thermal Characteristcs (Ratings at 25°C ambient temperature unless otherwise specified )**

Parameter	Symbol	SF16025CT,SF16025FCT		Unit
Operating junction	$T_J$	175		°C
Storage temperature range	$T_{STD}$	-55 to +175		
Typical thermal resistance (note3)	$R_{\theta JC}$	TO-220AB	TO-220F	°C/W
		2.5	4.5	

- Notes:
1. Pulse test: 300  $\mu s$  pulse width,1% duty cycle
  2. Pulse test: pulse width $\leq 40ms$
  3. Device mounted on Device mounted on 75mm x 45mm x 2.5mm Aluminum Plate Heatsink.

**SF16025CT, SF16025FCT**  
SUPER FAST RECOVERY RECTIFIERS



**RATING AND CHARACTERISTIC CURVES**

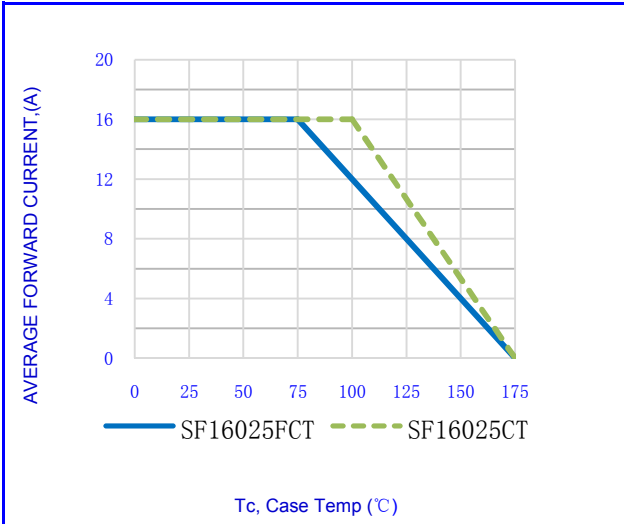

Fig.1-FORWARD CURRENT DERATING CURVE

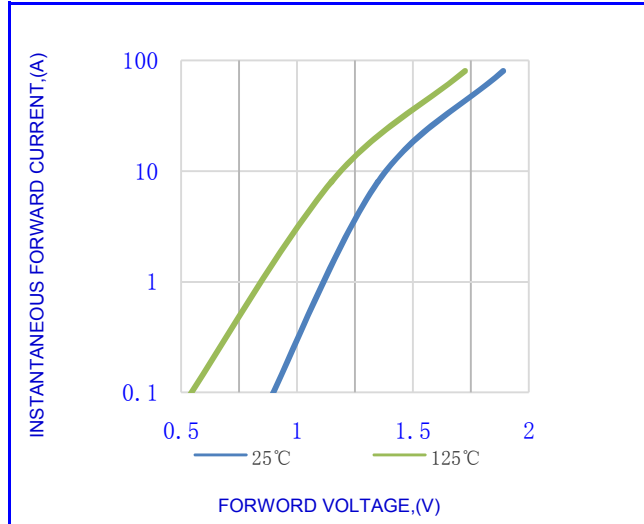

Fig.2-TYPICAL INSTANTANEOUS FORWARD

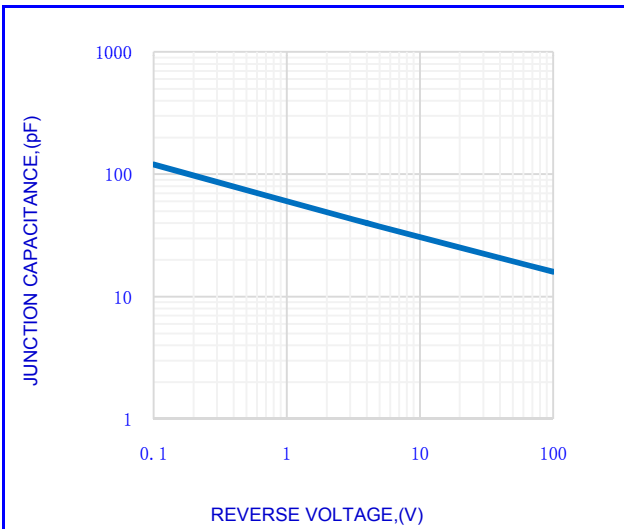

Fig.3-TYPICAL JUNCTION CAPACITANCE

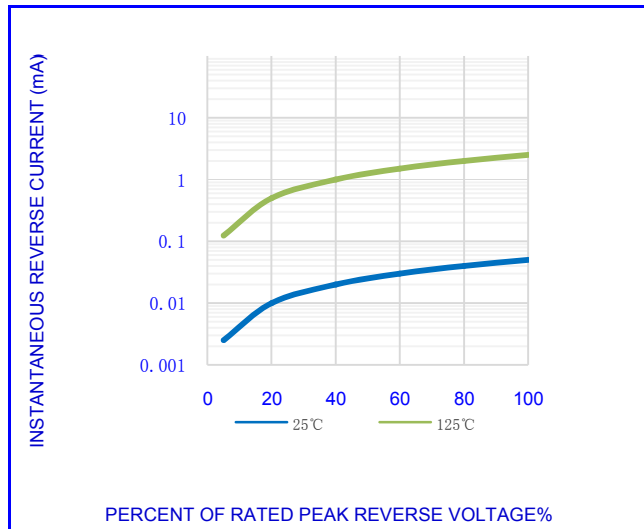

Fig.4-TYPICAL REVERSE CHARACTERISTICS

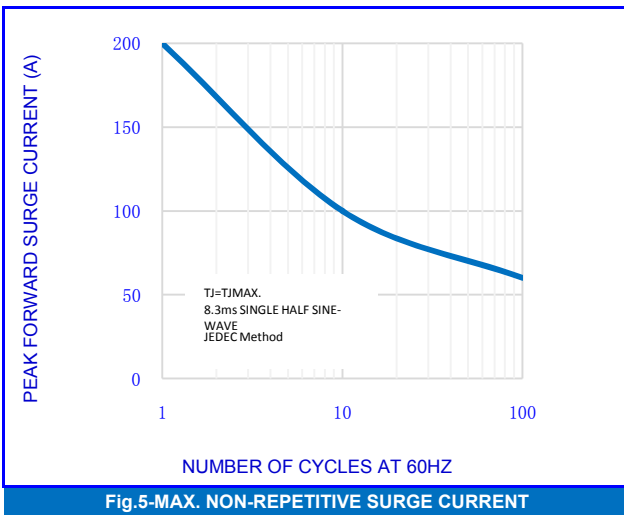

Fig.5-MAX. NON-REPETITIVE SURGE CURRENT

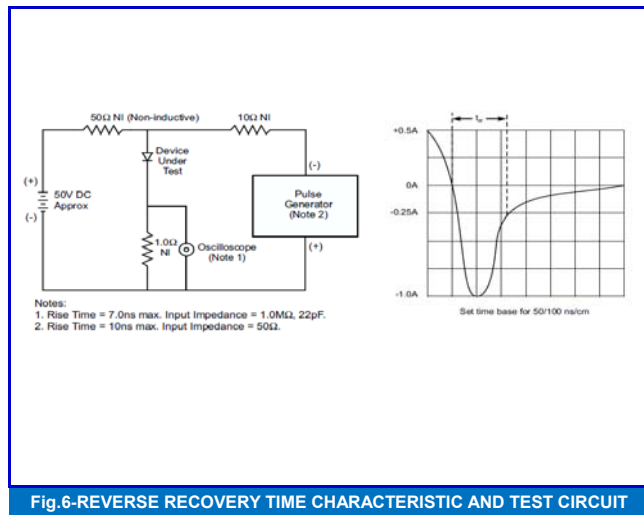

Fig.6-REVERSE RECOVERY TIME CHARACTERISTIC AND TEST CIRCUIT

**SF16025CT,SF16025FCT**  
SUPER FAST RECOVERY RECTIFIERS



**OUTLINE DRAWINGS**

**TO-220AB**

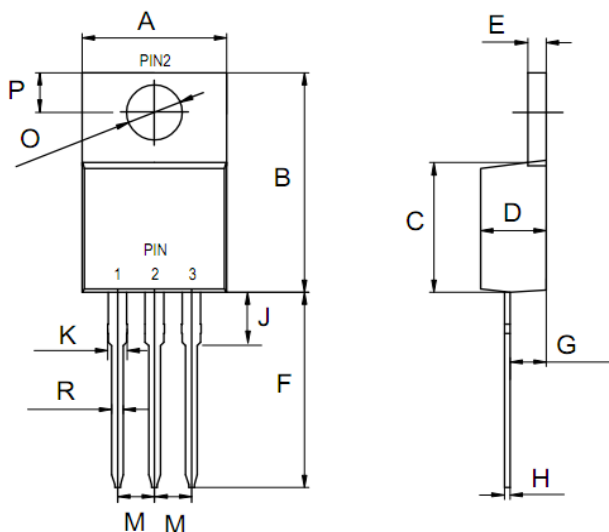

OUTLINE DIMENSIONS(Units:mm)						
Dim.	Milimeters			Inches		
	Min.	Typ.	Max.	Min.	Typ.	Max.
A	9.80	-	10.40	0.3858	-	0.4094
B	14.95	-	15.35	0.5886	-	0.6043
C	8.40	-	9.40	0.3307	-	0.3701
D	4.20	-	4.70	0.1654	-	0.1850
E	1.15	-	1.45	0.0453	-	0.0571
F	12.50	-	-	0.4921	-	-
G	2.30	-	2.70	0.0906	-	0.1063
H	0.30	-	0.45	0.0118	-	0.0177
J	3.00	-	4.50	0.1181	-	0.1772
M	2.44	-	2.64	0.0961	-	0.1039
R	0.70	-	1.00	0.0276	-	0.0394
O	3.45	-	3.85	0.1358	-	0.1516
P	2.80	-	3.20	0.1102	-	0.1260

**OUTLINE DRAWINGS**

**TO-220F**

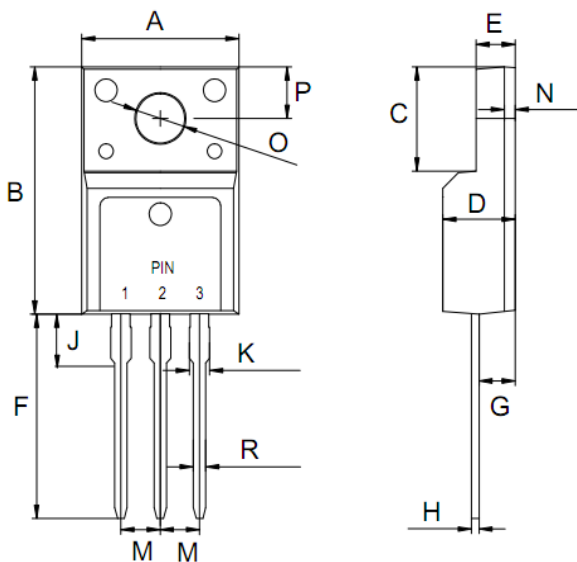

OUTLINE DIMENSIONS(MILI METERS)						
Dim.	Milimeters			Inches		
	Min.	Typ.	Max.	Min.	Typ.	Max.
A	9.91	10.21	10.41	0.3902	0.4020	0.4098
B	28.10	29.22	29.50	1.1063	1.1504	1.1614
C	6.20	6.75	7.20	0.2441	0.2657	0.2835
D	4.44	4.70	4.80	0.1748	0.1850	0.1890
E	2.45	2.57	3.55	0.0965	0.1012	0.1398
F	13.10	13.22	14.22	0.5157	0.5205	0.5598
G	2.25	2.40	2.60	0.0886	0.0945	0.1024
H	0.35	0.50	0.58	0.0138	0.0197	0.0228
J	2.60	2.88	4.00	0.1024	0.1134	0.1575
M	2.41	2.50	2.67	0.0949	0.0984	0.1051
N	4.88	5.00	5.28	0.1921	0.1969	0.2079
R	0.58	0.82	0.94	0.0228	0.0323	0.0370
O	3.25	3.55	3.75	0.1280	0.1398	0.1476
P	2.15	3.30	3.50	0.0846	0.1299	0.1378

**Packing Information**

Package Code	Package Method	Tube Size L×W×H(mm)	Quantity (pcs/Tube)	Inner Box Size L×W×H(mm)	Quantity (pcs/Inner Box)	Outer Carton Size L×W×H(mm)	Quantity (pcs/carton)
TO-220AB	Tube	530x35x8	50	560x155x55	1000	570×284×185	5000
TO-220F	Tube	530x35x8	50	560x155x55	1000	570×284×185	5000

**SF16025CT,SF16025FCT**  
SUPER FAST RECOVERY RECTIFIERS



**Recommended wave soldering condition**

Product	Peak Temperature	Soldering Time
Pb-free devices	260 +0/-5 °C	5 +1/-1 seconds

**Recommended temperature profile for IR reflow**

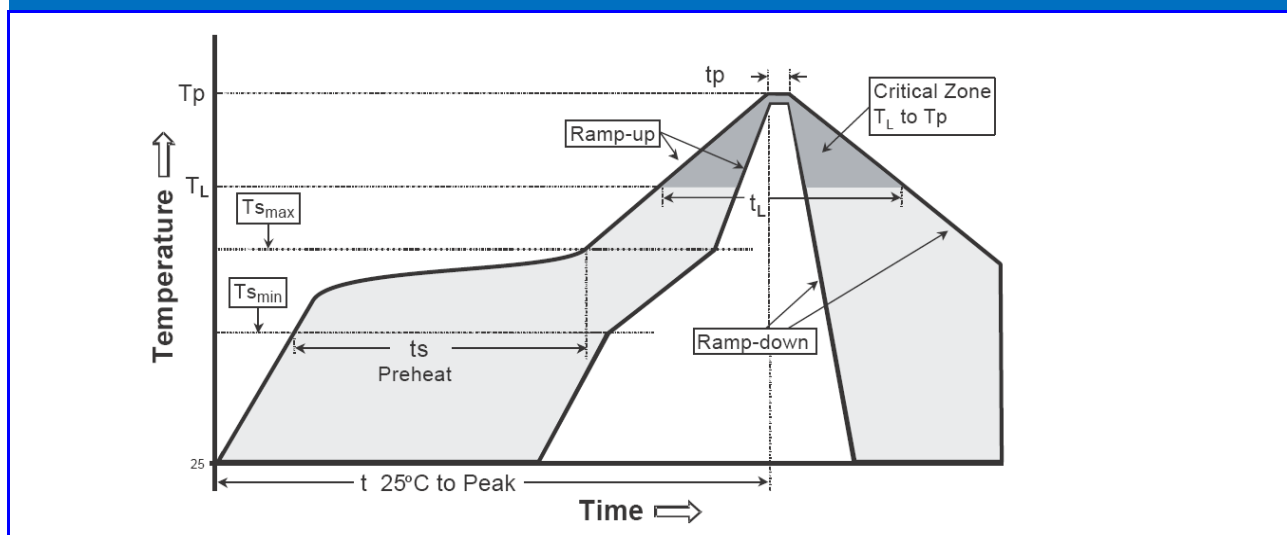

Profile feature	Sn-Pb eutectic Assembly	Pb-free Assembly
Average ramp-up rate (Tsmmax to Tp)	3°C/second max.	3°C/second max.
Preheat -Temperature Min(TS min) -Temperature Max(TS max) -Time(ts min to ts max)	100°C 150°C 60-120 seconds	150°C 200°C 60-180 seconds
Time maintained above: -Temperature (TL) - Time (tL)	183°C 60-150 seconds	217°C 60-150 seconds
Peak Temperature(TP)	240 +0/-5 °C	260 +0/-5 °C
Time within 5°C of actual peak temperature(tp)	10-30 seconds	20-40 seconds
Ramp down rate	6°C/second max.	6°C/second max.
Time 25 °C to peak temperature	6 minutes max.	8 minutes max.

Note : All temperatures refer to topside of the package, measured on the package body surface.

**SF16025CT,SF16025FCT**  
SUPER FAST RECOVERY RECTIFIERS



**Disclaimer**

- Reproducing and modifying information of the document is prohibited without permission from niuhang Electronics co., LTD
- Niuhan Electronics co., LTD. reserves the rights to make changes of the content herein the document anytime without notification.
- Niuhan Electronics co., LTD. disclaims any and all liability arising out of the application or use of any product including damages incidentally and consequentially occurred.
- Niuhan Electronics co., LTD. does not assume any and all implied warranties, including warranties of fitness for particular purpose, non-infringement and merchantability.
- Applications shown on the herein document are examples of standard use and operation. Customers are responsible in comprehending the suitable use in particular applications. Niuhan Electronics co., LTD. makes no representation or warranty that such applications will be suitable for the specified use without further testing or modification.
- The products shown herein are not designed and authorized for equipments requiring high level of reliability or relating to human life and for any applications concerning life-saving or life-sustaining, such as medical instruments, transportation equipment, aerospace machinery et cetera. Customers using or selling these products for use in such applications do so at their own risk and agree to fully indemnify Niuhan Electronics co., LTD. for any damages resulting from such improper use or sale.
- When the appearance of the product and chip size does not change, in order to product the customer. quality, change the internal structure and the production process Niuhan can not notify

## X-ON Electronics

Largest Supplier of Electrical and Electronic Components

*Click to view similar products for [Rectifiers](#) category:*

*Click to view products by [NH manufacturer](#):*

Other Similar products are found below :

[70HFR40](#) [FR105 R0](#) [RL252-TP](#) [1N5397](#) [1N4005-TR](#) [1N4007-BP](#) [UFS120Je3/TR13](#) [20ETS12S](#) [RRE02VS6SGTR](#) [MS306](#) [A1N5404G-G](#)  
[CRF02\(T5L,TEMQ\)](#) [ACGRB207-HF](#) [CLH07\(TE16L,Q\)](#) [CLH03\(TE16L,Q\)](#) [1N5395-TP](#) [UES1302](#) [ACGRC307-HF](#) [ACEFC304-HF](#) [DZ-](#)  
[1380](#) [85HFR60](#) [40HFR60](#) [70HF120](#) [85HFR80](#) [SCF7500](#) [SM100](#) [ACGRA4001-HF](#) [SKN70/08](#) [NTE5819](#) [NTE5827](#) [NTE5828](#) [NTE5911](#)  
[NTE5915](#) [NTE6104](#) [NTE6163](#) [NTE6164](#) [NTE6165](#) [NTE6364](#) [TSD3G](#) [SET130312](#) [NRVUS110VT3G](#) [UES1106](#) [UES1306](#)  
[NRVUS240VT3G](#) [D5FE60-5063](#) [R4000GPS-TP](#) [D4015L56TP](#) [UES1306HR2](#) [FX20K120](#) [D20XB60-7101](#)