

FEATURES

- NON-SHIELDED MAGNETIC CIRCUIT DESIGN
- SMALL SIZE WITH CURRENT RATINGS TO 16.5 AMPS
- SURFACE MOUNTABLE CONSTRUCTION
- TAKES UP LESS PCB REAL ESTATE AND SAVES MORE POWER
- TAPED AND REELED FOR AUTOMATIC INSERTION
- FOR USE IN VARIOUS POWER SUPPLY APPLICATIONS

**RoHS
Compliant**
includes all homogeneous materials

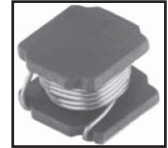

*See Part Number System for Details

Case Size	NPI31LS	NPI32LS	NPI35LS	NPI41LS	NPI42LS
Inductance Range	1.2 ~ 47 μ H	0.75 ~ 82 μ H	0.68 ~ 47 μ H	0.68 ~ 68 μ H	1.2 ~ 82 μ H
Operating Temperature Range	-25°C ~ +120°C (Including Self-Heating)				
Temperature Rise at Irms	+40°C				
Inductance Change at Isat	Maximum -30% Inductance Drop From Initial Measured Value				
Inductance Tolerance	±20%				
Resistance to Solder Heat	+260°C for 10 seconds				

Case Size	NPI43LS	NPI63LS	NPI65LS	NPI84LS
Inductance Range	0.91 ~ 330 μ H	1.2 ~ 82 μ H	1.0 ~ 270 μ H	0.75 ~ 82 μ H
Ambient Operating Temperature Range	-25°C ~ +120°C (Including Self-Heating)			
Temperature Rise at Irms	+40°C			
Inductance Change at Isat	Maximum -30% Inductance Drop From Initial Measured Value			
Inductance Tolerance	±20%			
Resistance to Solder Heat	+260°C for 10 seconds			

Series	A ± 0.3	B ± 0.3	C max.	D ± 0.3	F ± 0.3	H	I	G
NPI31LS	3.0	3.0	1.2	0.75	1.5	2.7	0.8	2.3
NPI32LS	3.0	3.0	1.4	0.75	1.5	2.7	0.8	2.3
NPI35LS	3.0	3.0	1.7	0.75	1.5	2.7	0.8	2.3
NPI41LS	4.0	4.0	1.4	0.95	2.1	3.7	1.1	3.0
NPI42LS	4.0	4.0	2.2	0.95	2.1	3.7	1.1	3.0
NPI43LS	4.0	4.0	3.0	0.95	2.1	3.7	1.1	3.0
NPI63LS	6.0	6.0	2.8	1.55	2.9	5.7	1.6	4.6
NPI65LS	6.0	6.0	4.5	1.55	2.9	5.7	1.6	4.6
NPI84LS	8.0	8.0	4.2	2.0	4.0	7.5	2.2	6.0

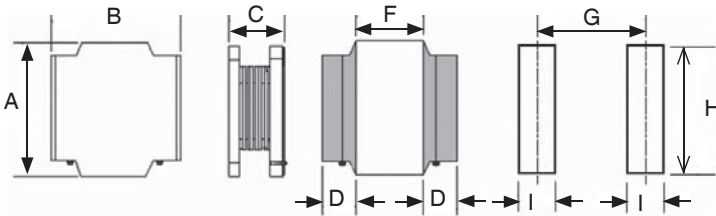

PART NUMBER SYSTEM

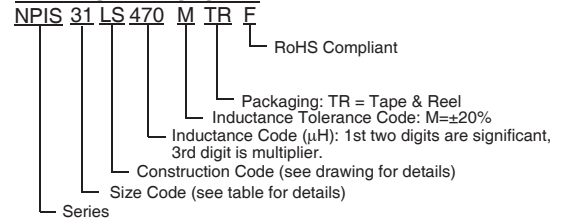

Series	Standard Values - Case Size 31 (3.0 x 3.0 x 1.2mm)						
	Inductance (μH)	Tolerance	Test Conditions	DCR (Ω)	Isat (Amps)	Irms (Amps)	SRF (MHz)
NPI31LS1R2MTRF	1.2	±20%	100KHz, 1V	0.082	2.25	1.14	170
NPI31LS1R5MTRF	1.5	±20%	100KHz, 1V	0.097	2.02	1.05	140
NPI31LS1R8MTRF	1.8	±20%	100KHz, 1V	0.108	1.75	1.0	110
NPI31LS2R2MTRF	2.2	±20%	100KHz, 1V	0.125	1.64	0.9	100
NPI31LS2R7MTRF	2.7	±20%	100KHz, 1V	0.143	1.51	0.85	91
NPI31LS3R3MTRF	3.3	±20%	100KHz, 1V	0.169	1.37	0.8	85
NPI31LS3R9MTRF	3.9	±20%	100KHz, 1V	0.21	1.24	0.7	77
NPI31LS4R7MTRF	4.7	±20%	100KHz, 1V	0.243	1.16	0.65	70
NPI31LS5R6MTRF	5.6	±20%	100KHz, 1V	0.306	1.04	0.6	63
NPI31LS6R2MTRF	6.2	±20%	100KHz, 1V	0.333	0.98	0.55	62
NPI31LS6R8MTRF	6.8	±20%	100KHz, 1V	0.383	0.92	0.5	56
NPI31LS7R5MTRF	7.5	±20%	100KHz, 1V	0.389	0.88	0.5	53
NPI31LS9R1MTRF	9.1	±20%	100KHz, 1V	0.502	0.77	0.45	46
NPI31LS100MTRF	10	±20%	100KHz, 1V	0.526	0.75	0.45	43
NPI31LS120MTRF	12	±20%	100KHz, 1V	0.599	0.7	0.4	41
NPI31LS150MTRF	15	±20%	100KHz, 1V	0.772	0.62	0.35	36
NPI31LS180MTRF	18	±20%	100KHz, 1V	1.06	0.56	0.3	32
NPI31LS220MTRF	22	±20%	100KHz, 1V	1.11	0.52	0.3	30
NPI31LS270MTRF	27	±20%	100KHz, 1V	1.38	0.48	0.25	26
NPI31LS330MTRF	33	±20%	100KHz, 1V	1.8	0.42	0.25	24
NPI31LS360MTRF	36	±20%	100KHz, 1V	1.95	0.42	0.2	24
NPI31LS390MTRF	39	±20%	100KHz, 1V	2.095	0.4	0.2	23
NPI31LS470MTRF	47	±20%	100KHz, 1V	2.46	0.36	0.2	19

Irms specification is based on +20°C temperature rise. Isat is based on -30% inductance change.

Series	Standard Values - Case Size 32 (3.0 x 3.0 x 1.4mm)						
	Inductance (μH)	Tolerance	Test Conditions	DCR (Ω)	Isat (Amps)	Irms (Amps)	SRF (MHz)
NPI32LSR75MTRF	0.75	±20%	100KHz, 1V	0.037	3.31	1.74	180
NPI32LS1R0MTRF	1.0	±20%	100KHz, 1V	0.045	2.93	1.59	150
NPI32LS2R2MTRF	2.2	±20%	100KHz, 1V	0.097	2.02	1.08	100
NPI32LS3R3MTRF	3.3	±20%	100KHz, 1V	0.164	1.62	0.83	81
NPI32LS3R9MTRF	3.9	±20%	100KHz, 1V	0.177	1.49	0.8	72
NPI32LS4R7MTRF	4.7	±20%	100KHz, 1V	0.212	1.36	0.73	65
NPI32LS5R6MTRF	5.6	±20%	100KHz, 1V	0.227	1.28	0.71	60
NPI32LS6R2MTRF	6.2	±20%	100KHz, 1V	0.246	1.22	0.68	56
NPI32LS 6R8MTRF	6.8	±20%	100KHz, 1V	0.27	1.16	0.65	51
NPI32LS7R5MTRF	7.5	±20%	100KHz, 1V	0.285	1.07	0.63	46
NPI32LS9R1MTRF	9.1	±20%	100KHz, 1V	0.357	0.98	0.56	44
NPI32LS100MTRF	10	±20%	100KHz, 1V	0.378	0.95	0.55	43
NPI32LS120MTRF	12	±20%	100KHz, 1V	0.503	0.84	0.48	37
NPI32LS150MTRF	15	±20%	100KHz, 1V	0.663	0.75	0.41	31
NPI32LS180MTRF	18	±20%	100KHz, 1V	0.762	0.68	0.39	30
NPI32LS220MTRF	22	±20%	100KHz, 1V	0.864	0.62	0.36	27
NPI32LS270MTRF	27	±20%	100KHz, 1V	1.005	0.57	0.34	23
NPI32LS330MTRF	33	±20%	100KHz, 1V	1.145	0.5	0.32	20
NPI32LS360MTRF	36	±20%	100KHz, 1V	1.49	0.48	0.28	21
NPI32LS390MTRF	39	±20%	100KHz, 1V	1.585	0.47	0.27	20
NPI32LS470MTRF	47	±20%	100KHz, 1V	1.78	0.44	0.25	18
NPI32LS510MTRF	51	±20%	100KHz, 1V	1.88	0.42	0.25	17
NPI32LS560MTRF	56	±20%	100KHz, 1V	2.21	0.38	0.23	15
NPI32LS620MTRF	62	±20%	100KHz, 1V	2.19	0.39	0.23	15
NPI32LS680MTRF	68	±20%	100KHz, 1V	2.99	0.35	0.2	14
NPI32LS820MTRF	82	±20%	100KHz, 1V	3.505	0.31	0.18	13

Irms specification is based on +20°C temperature rise. Isat is based on -30% inductance change.



Series	Standard Values - Case Size 35 (3.0 x 3.0 x 1.7mm)						
	Inductance (μH)	Tolerance	Test Conditions	DCR (Ω)	Isat (Amps)	Irms (Amps)	SRF (MHz)
NPI35LSR68MTRF	0.68	±20%	100KHz, 1V	0.028	3.81	2.23	170
NPI35LS1R0MTRF	1.0	±20%	100KHz, 1V	0.04	3.27	1.85	150
NPI35LS1R2MTRF	1.2	±20%	100KHz, 1V	0.053	2.84	1.61	133
NPI35LS1R5MTRF	1.5	±20%	100KHz, 1V	0.06	2.6	1.51	113
NPI35LS1R8MTRF	1.8	±20%	100KHz, 1V	0.068	2.32	1.41	96
NPI35LS2R2MTRF	2.2	±20%	100KHz, 1V	0.089	2.07	1.24	91
NPI35LS2R7MTRF	2.7	±20%	100KHz, 1V	0.106	1.01	1.13	80
NPI35LS3R3MTRF	3.3	±20%	100KHz, 1V	0.116	1.79	1.09	75
NPI35LS3R6MTRF	3.6	±20%	100KHz, 1V	0.128	1.66	1.03	66
NPI35LS3R9MTRF	3.9	±20%	100KHz, 1V	0.146	1.62	0.97	65
NPI35LS4R7MTRF	4.7	±20%	100KHz, 1V	0.206	1.44	0.82	57
NPI35LS5R6MTRF	5.6	±20%	100KHz, 1V	0.222	1.37	0.79	54
NPI35LS6R8MTRF	6.8	±20%	100KHz, 1V	0.253	1.24	0.73	50
NPI35LS100MTRF	10	±20%	100KHz, 1V	0.328	1.06	0.65	26
NPI35LS120MTRF	12	±20%	100KHz, 1V	0.451	0.9	0.55	32
NPI35LS150MTRF	15	±20%	100KHz, 1V	0.52	0.82	0.5	30
NPI35LS180MTRF	18	±20%	100KHz, 1V	0.565	0.75	0.5	28
NPI35LS220MTRF	22	±20%	100KHz, 1V	0.763	0.7	0.42	25
NPI35LS270MTRF	27	±20%	100KHz, 1V	1.006	0.62	0.37	21
NPI35LS330MTRF	33	±20%	100KHz, 1V	1.156	0.56	0.34	18
NPI35LS360MTRF	36	±20%	100KHz, 1V	1.223	0.53	0.33	18
NPI35LS390MTRF	39	±20%	100KHz, 1V	1.298	0.51	0.32	17
NPI35LS430MTRF	43	±20%	100KHz, 1V	1.372	0.5	0.32	17
NPI35LS470MTRF	47	±20%	100KHz, 1V	1.447	0.48	0.31	16

Irms specification is based on +20°C temperature rise. Isat is based on -30% inductance change.

Series	Standard Values - Case Size 41 (4.0 x 4.0 x 1.4mm)						
	Inductance (μH)	Tolerance	Test Conditions	DCR (Ω)	Isat (Amps)	Irms (Amps)	SRF (MHz)
NPI41LSR68MTRF	0.68	±20%	100KHz, 1V	0.053	4.56	1.63	140
NPI41LS1R0MTRF	1.0	±20%	100KHz, 1V	0.067	3.74	1.45	140
NPI41LS1R5MTRF	1.5	±20%	100KHz, 1V	0.081	3.16	1.32	110
NPI41LS1R8MTRF	1.8	±20%	100KHz, 1V	0.097	2.85	1.2	100
NPI41LS2R7MTRF	2.7	±20%	100KHz, 1V	0.113	2.56	1.12	86
NPI41LS3R3MTRF	3.3	±20%	100KHz, 1V	0.129	2.32	1.04	79
NPI41LS3R6MTRF	3.6	±20%	100KHz, 1V	0.147	2.18	0.98	68
NPI41LS4R7MTRF	4.7	±20%	100KHz, 1V	0.164	1.98	0.92	63
NPI41LS5R1MTRF	5.1	±20%	100KHz, 1V	0.182	1.82	0.88	57
NPI41LS6R8MTRF	6.8	±20%	100KHz, 1V	0.269	1.6	0.72	49
NPI41LS7R5MTRF	7.5	±20%	100KHz, 1V	0.289	1.49	0.7	46
NPI41LS8R2MTRF	8.2	±20%	100KHz, 1V	0.313	1.4	0.67	42
NPI41LS9R1MTRF	9.1	±20%	100KHz, 1V	0.339	1.36	0.64	41
NPI41LS100MTRF	10	±20%	100KHz, 1V	0.367	1.31	0.62	39
NPI41LS120MTRF	12	±20%	100KHz, 1V	0.394	1.23	0.6	35
NPI41LS150MTRF	15	±20%	100KHz, 1V	0.502	1.09	0.53	31
NPI41LS180MTRF	18	±20%	100KHz, 1V	0.587	1.0	0.49	28
NPI41LS220MTRF	22	±20%	100KHz, 1V	0.791	0.89	0.42	26
NPI41LS270MTRF	27	±20%	100KHz, 1V	0.905	0.82	0.39	22
NPI41LS330MTRF	33	±20%	100KHz, 1V	1.196	0.71	0.34	20
NPI41LS360MTRF	36	±20%	100KHz, 1V	1.246	0.68	0.34	19
NPI41LS390MTRF	39	±20%	100KHz, 1V	1.341	0.65	0.32	17
NPI41LS430MTRF	43	±20%	100KHz, 1V	1.451	0.63	0.31	18
NPI41LS470MTRF	47	±20%	100KHz, 1V	1.558	0.61	0.3	16
NPI41LS510MTRF	51	±20%	100KHz, 1V	1.664	0.58	0.29	15
NPI41LS620MTRF	62	±20%	100KHz, 1V	2.223	0.51	0.25	14
NPI41LS680MTRF	68	±20%	100KHz, 1V	2.37	0.49	0.24	13

Irms specification is based on +20°C temperature rise. Isat is based on -30% inductance change.



Series	Standard Values - Case Size 42 (4.0 x 4.0 x 2.2mm)						
	Inductance (μH)	Tolerance	Test Conditions	DCR (Ω)	Isat (Amps)	Irms (Amps)	SRF (MHz)
NPI42LS1R2MTRF	1.2	±20%	100KHz, 1V	0.029	5.98	2.16	100
NPI42LS1R5MTRF	1.5	±20%	100KHz, 1V	0.04	5.23	1.86	85
NPI42LS1R8MTRF	1.8	±20%	100KHz, 1V	0.045	4.77	1.74	74
NPI42LS2R2MTRF	2.2	±20%	100KHz, 1V	0.051	4.33	1.63	64
NPI42LS2R7MTRF	2.7	±20%	100KHz, 1V	0.057	3.74	1.54	61
NPI42LS3R3MTRF	3.3	±20%	100KHz, 1V	0.074	3.55	1.36	55
NPI42LS3R9MTRF	3.9	±20%	100KHz, 1V	0.081	3.34	1.29	48
NPI42LS4R7MTRF	4.7	±20%	100KHz, 1V	0.09	3.11	1.23	45
NPI42LS5R6MTRF	5.6	±20%	100KHz, 1V	0.117	2.84	1.08	41
NPI42LS6R2MTRF	6.2	±20%	100KHz, 1V	0.126	2.69	1.04	38
NPI42LS6R8MTRF	6.8	±20%	100KHz, 1V	0.136	2.54	1.0	35
NPI42LS8R2MTRF	8.2	±20%	100KHz, 1V	0.162	2.4	0.92	33
NPI42LS9R1MTRF	9.1	±20%	100KHz, 1V	0.172	2.3	0.89	32
NPI42LS100MTRF	10	±20%	100KHz, 1V	0.184	2.2	0.86	30
NPI42LS120MTRF	12	±20%	100KHz, 1V	0.233	1.95	0.76	26
NPI42LS150MTRF	15	±20%	100KHz, 1V	0.327	1.73	0.65	23
NPI42LS180MTRF	18	±20%	100KHz, 1V	0.366	1.56	0.61	20
NPI42LS220MTRF	22	±20%	100KHz, 1V	0.559	1.41	0.49	19
NPI42LS270MTRF	27	±20%	100KHz, 1V	0.62	1.28	0.47	17
NPI42LS330MTRF	33	±20%	100KHz, 1V	0.712	1.16	0.44	15
NPI42LS360MTRF	36	±20%	100KHz, 1V	0.753	1.12	0.43	14
NPI42LS390MTRF	39	±20%	100KHz, 1V	0.806	1.06	0.41	14
NPI42LS430MTRF	43	±20%	100KHz, 1V	0.849	1.02	0.4	14
NPI42LS470MTRF	47	±20%	100KHz, 1V	0.9	1.0	0.39	13
NPI42LS510MTRF	51	±20%	100KHz, 1V	1.11	0.91	0.35	11
NPI42LS560MTRF	56	±20%	100KHz, 1V	1.162	0.89	0.34	11
NPI42LS620MTRF	62	±20%	100KHz, 1V	1.227	0.84	0.33	10
NPI42LS680MTRF	68	±20%	100KHz, 1V	1.317	0.8	0.32	9.4
NPI42LS750MTRF	75	±20%	100KHz, 1V	1.375	0.78	0.31	9.2
NPI42LS820MTRF	82	±20%	100KHz, 1V	1.465	0.75	0.3	9.2

Irms specification is based on +20°C temperature rise. Isat is based on -30% inductance change.



Series	Standard Values - Case Size 43 (4.0 x 4.0 x 3.0mm)						
	Inductance (μH)	Tolerance	Test Conditions	DCR (Ω)	Isat (Amps)	Irms (Amps)	SRF (MHz)
NPI43LSR91MTRF	0.91	±20%	100KHz, 1V	0.015	7.8	3.65	98
NPI43LS1R2MTRF	1.2	±20%	100KHz, 1V	0.02	6.83	3.18	77
NPI43LS1R5MTRF	1.5	±20%	100KHz, 1V	0.023	6.13	2.97	73
NPI43LS1R8MTRF	1.8	±20%	100KHz, 1V	0.027	5.62	2.75	63
NPI43LS2R2MTRF	2.2	±20%	100KHz, 1V	0.03	5.03	2.63	56
NPI43LS2R7MTRF	2.7	±20%	100KHz, 1V	0.039	4.6	2.29	52
NPI43LS3R3MTRF	3.3	±20%	100KHz, 1V	0.053	4.16	1.97	44
NPI43LS3R9MTRF	3.9	±20%	100KHz, 1V	0.058	3.91	1.88	41
NPI43LS4R7MTRF	4.7	±20%	100KHz, 1V	0.063	3.64	1.81	38
NPI43LS5R1MTRF	5.1	±20%	100KHz, 1V	0.068	3.47	1.74	36
NPI43LS5R6MTRF	5.6	±20%	100KHz, 1V	0.085	3.16	1.55	30
NPI43LS6R2MTRF	6.2	±20%	100KHz, 1V	0.091	3.04	1.51	30
NPI43LS6R8MTRF	6.8	±20%	100KHz, 1V	0.098	2.89	1.45	28
NPI43LS8R2MTRF	8.2	±20%	100KHz, 1V	0.119	2.68	1.32	25
NPI43LS100MTRF	10	±20%	100KHz, 1V	0.134	2.48	1.24	24
NPI43LS120MTRF	12	±20%	100KHz, 1V	0.162	2.2	1.13	20
NPI43LS150MTRF	15	±20%	100KHz, 1V	0.206	1.99	1.0	17
NPI43LS180MTRF	18	±20%	100KHz, 1V	0.241	1.82	0.92	18
NPI43LS220MTRF	22	±20%	100KHz, 1V	0.292	1.56	0.84	15
NPI43LS270MTRF	27	±20%	100KHz, 1V	0.332	1.55	0.79	13
NPI43LS330MTRF	33	±20%	100KHz, 1V	0.431	1.35	0.69	12
NPI43LS390MTRF	39	±20%	100KHz, 1V	0.497	1.23	0.64	12
NPI43LS470MTRF	47	±20%	100KHz, 1V	0.594	1.12	0.59	11
NPI43LS560MTRF	56	±20%	100KHz, 1V	1.013	0.96	0.45	8.8
NPI43LS680MTRF	68	±20%	100KHz, 1V	1.048	0.92	0.44	8.6
NPI43LS750MTRF	75	±20%	100KHz, 1V	1.108	0.9	0.43	8.5
NPI43LS820MTRF	82	±20%	100KHz, 1V	1.187	0.87	0.42	8.2
NPI43LS910MTRF	91	±20%	100KHz, 1V	1.299	0.81	0.4	7.4
NPI43LS101MTRF	100	±20%	100KHz, 1V	1.327	0.8	0.39	7.6
NPI43LS331MTRF	330	±20%	100KHz, 1V	4.072	0.42	0.22	3.8

Irms specification is based on +20°C temperature rise. Isat is based on -30% inductance change.



Series	Standard Values - Case Size 63 (6.0 x 6.0 x 2.8mm)						
	Inductance (μH)	Tolerance	Test Conditions	DCR (Ω)	Isat (Amps)	Irms (Amps)	SRF (MHz)
NPI63LS1R2MTRF	1.2	±20%	100KHz, 1V	0.013	8.4	4.58	94
NPI63LS1R5MTRF	1.5	±20%	100KHz, 1V	0.016	7.14	4.09	80
NPI63LS2R2MTRF	2.2	±20%	100KHz, 1V	0.019	6.19	3.75	64
NPI63LS3R3MTRF	3.3	±20%	100KHz, 1V	0.028	4.89	3.08	46
NPI63LS4R3MTRF	4.3	±20%	100KHz, 1V	0.032	4.35	2.89	42
NPI63LS5R1MTRF	5.1	±20%	100KHz, 1V	0.04	4.04	2.58	37
NPI63LS6R2MTRF	6.2	±20%	100KHz, 1V	0.052	3.45	2.25	31
NPI63LS7R5MTRF	7.5	±20%	100KHz, 1V	0.058	3.27	2.15	31
NPI63LS8R2MTRF	8.2	±20%	100KHz, 1V	0.064	3.12	2.05	29
NPI63LS100MTRF	10	±20%	100KHz, 1V	0.084	2.81	1.79	25
NPI63LS120MTRF	12	±20%	100KHz, 1V	0.099	2.54	1.64	22
NPI63LS150MTRF	15	±20%	100KHz, 1V	0.114	2.29	1.53	20
NPI63LS180MTRF	18	±20%	100KHz, 1V	0.136	2.13	1.4	18
NPI63LS220MTRF	22	±20%	100KHz, 1V	0.163	1.9	1.28	16
NPI63LS330MTRF	33	±20%	100KHz, 1V	0.239	1.51	1.06	13
NPI63LS360MTRF	36	±20%	100KHz, 1V	0.25	1.47	1.05	12
NPI63LS390MTRF	39	±20%	100KHz, 1V	0.263	1.46	1.01	12
NPI63LS430MTRF	43	±20%	100KHz, 1V	0.273	1.46	0.99	12
NPI63LS470MTRF	47	±20%	100KHz, 1V	0.341	1.32	0.89	11
NPI63LS510MTRF	51	±20%	100KHz, 1V	0.371	1.24	0.85	10
NPI63LS560MTRF	56	±20%	100KHz, 1V	0.39	1.2	0.83	10
NPI63LS620MTRF	62	±20%	100KHz, 1V	0.422	1.15	0.8	10
NPI63LS680MTRF	68	±20%	100KHz, 1V	0.49	1.09	0.73	9.1
NPI63LS750MTRF	75	±20%	100KHz, 1V	0.527	1.05	0.7	8.7
NPI63LS820MTRF	82	±20%	100KHz, 1V	0.557	0.99	0.69	8.2

Irms specification is based on +20°C temperature rise. Isat is based on -30% inductance change.



Series	Standard Values - Case Size 65 (6.0 x 6.0 x 4.5mm)						
	Inductance (μH)	Tolerance	Test Conditions	DCR (Ω)	Isat (Amps)	Irms (Amps)	SRF (MHz)
NPI65LS1R0MTRF	1.0	±20%	100KHz, 1V	0.01	11.13	4.86	100
NPI65LS1R8MTRF	1.8	±20%	100KHz, 1V	0.014	8.38	4.17	60
NPI65LS2R2MTRF	2.2	±20%	100KHz, 1V	0.016	7.55	3.89	46
NPI65LS4R7MTRF	4.7	±20%	100KHz, 1V	0.029	5.18	2.85	31
NPI65LS5R6MTRF	5.6	±20%	100KHz, 1V	0.032	4.84	2.73	28
NPI65LS6R2MTRF	6.2	±20%	100KHz, 1V	0.035	4.52	2.62	25
NPI65LS100MTRF	10	±20%	100KHz, 1V	0.059	3.56	2.02	19
NPI65LS120MTRF	12	±20%	100KHz, 1V	0.07	3.32	1.85	17
NPI65LS150MTRF	15	±20%	100KHz, 1V	0.083	2.95	1.7	15
NPI65LS180MTRF	18	±20%	100KHz, 1V	0.092	2.74	1.61	14
NPI65LS220MTRF	22	±20%	100KHz, 1V	0.105	2.45	1.51	12
NPI65LS270MTRF	27	±20%	100KHz, 1V	0.141	2.18	1.3	10
NPI65LS330MTRF	33	±20%	100KHz, 1V	0.188	2.03	1.13	10
NPI65LS390MTRF	39	±20%	100KHz, 1V	0.211	1.8	1.06	8.8
NPI65LS470MTRF	47	±20%	100KHz, 1V	0.244	1.66	0.99	8.1
NPI65LS560MTRF	56	±20%	100KHz, 1V	0.296	1.57	0.9	7.8
NPI65LS620MTRF	62	±20%	100KHz, 1V	0.309	1.48	0.88	7.4
NPI65LS680MTRF	68	±20%	100KHz, 1V	0.346	1.39	0.83	6.5
NPI65LS750MTRF	75	±20%	100KHz, 1V	0.364	1.35	0.81	6.0
NPI65LS820MTRF	82	±20%	100KHz, 1V	0.437	1.29	0.74	5.6
NPI65LS910MTRF	91	±20%	100KHz, 1V	0.476	1.2	0.71	5.6
NPI65LS101MTRF	100	±20%	100KHz, 1V	0.506	1.14	0.69	4.1
NPI65LS181MTRF	180	±20%	100KHz, 1V	0.847	0.89	0.53	3.3
NPI65LS271MTRF	270	±20%	100KHz, 1V	1.073	0.74	0.47	2.2

Irms specification is based on +20°C temperature rise. Isat is based on -30% inductance change.



Series	Standard Values - Case Size 84 (8.0 x 8.0 x 4.2mm)						
	Inductance (μH)	Tolerance	Test Conditions	DCR (Ω)	Isat (Amps)	Irms (Amps)	SRF (MHz)
NPI84LSR75MTRF	0.75	±20%	100KHz, 1V	0.008	16.5	6.3	110
NPI84LS1R2MTRF	1.2	±20%	100KHz, 1V	0.01	13.3	5.65	82
NPI84LS1R8MTRF	1.8	±20%	100KHz, 1V	0.012	11.4	5.15	60
NPI84LS2R2MTRF	2.2	±20%	100KHz, 1V	0.014	9.65	4.7	40
NPI84LS3R3MTRF	3.3	±20%	100KHz, 1V	0.017	8.55	4.35	37
NPI84LS3R9MTRF	3.9	±20%	100KHz, 1V	0.019	7.75	4.05	42
NPI84LS4R7MTRF	4.7	±20%	100KHz, 1V	0.022	7.0	3.85	30
NPI84LS5R6MTRF	5.6	±20%	100KHz, 1V	0.024	6.5	3.6	27
NPI84LS6R8MTRF	6.8	±20%	100KHz, 1V	0.027	5.95	3.45	24
NPI84LS8R2MTRF	8.2	±20%	100KHz, 1V	0.03	5.55	3.3	22
NPI84LS9R1MTRF	9.1	±20%	100KHz, 1V	0.032	5.2	3.1	21
NPI84LS100MTRF	10	±20%	100KHz, 1V	0.043	4.78	2.7	18
NPI84LS120MTRF	12	±20%	100KHz, 1V	0.047	4.48	2.6	17
NPI84LS150MTRF	15	±20%	100KHz, 1V	0.054	4.0	2.4	15
NPI84LS180MTRF	18	±20%	100KHz, 1V	0.07	3.6	2.1	13
NPI84LS220MTRF	22	±20%	100KHz, 1V	0.079	3.33	2.0	13
NPI84LS270MTRF	27	±20%	100KHz, 1V	0.097	3.03	1.8	11
NPI84LS330MTRF	33	±20%	100KHz, 1V	0.115	2.73	1.65	10
NPI84LS360MTRF	36	±20%	100KHz, 1V	0.131	2.58	1.55	10
NPI84LS390MTRF	39	±20%	100KHz, 1V	0.136	2.5	1.55	10
NPI84LS430MTRF	43	±20%	100KHz, 1V	0.148	2.39	1.45	9.2
NPI84LS470MTRF	47	±20%	100KHz, 1V	0.188	2.2	1.3	8.5
NPI84LS510MTRF	51	±20%	100KHz, 1V	0.189	2.2	1.3	8.4
NPI84LS560MTRF	56	±20%	100KHz, 1V	0.197	2.12	1.25	8.1
NPI84LS620MTRF	62	±20%	100KHz, 1V	0.212	2.0	1.2	8.1
NPI84LS680MTRF	68	±20%	100KHz, 1V	0.277	1.8	1.05	6.8
NPI84LS750MTRF	75	±20%	100KHz, 1V	0.294	1.77	1.0	6.4
NPI84LS820MTRF	82	±20%	100KHz, 1V	0.312	1.7	1.0	6.3

Irms specification is based on +20°C temperature rise. Isat is based on -30% inductance change.



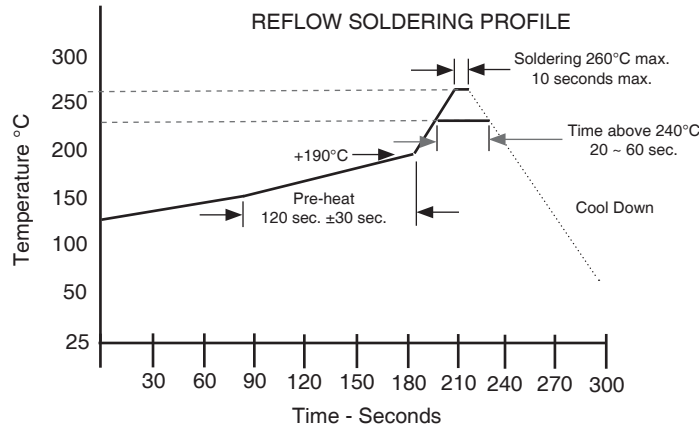

Case Size	CARRIER TAPING DIMENSIONS (mm) AND REEL QUANTITY							Quantity
	Ao	Bo	Ko	Co	W	Po	t	
NPI31LS	3.3 ± 0.1	3.3 ± 0.1	1.4 ± 0.1	3.5 ± 0.1	8.0 ± 0.3	4.0 ± 0.1	0.3 ± 0.03	2,000
NPI32LS			1.6 ± 0.1					2,000
NPI35LS			1.9 ± 0.1					2,000
NPI41LS	4.4 ± 0.1	4.4 ± 0.1	1.6 ± 0.1	3.5 ± 0.1	8.0 ± 0.3	8.0 ± 0.1	0.3 ± 0.03	4,500
NPI42LS			2.4 ± 0.1					3,000
NPI43LS			3.4 ± 0.1					2,000
NPI63LS	6.4 ± 0.1	6.4 ± 0.1	3.3 ± 0.1	7.5 ± 0.1	16.0 ± 0.3	8.0 ± 0.1	0.4 ± 0.03	2,000
NPI64LS			4.7 ± 0.1					1,500
NPI84LS	8.35 ± 0.1	8.35 ± 0.1	4.4 ± 0.1	7.5 ± 0.1	16.0 ± 0.3	12.0 ± 0.1	0.4 ± 0.03	1,000

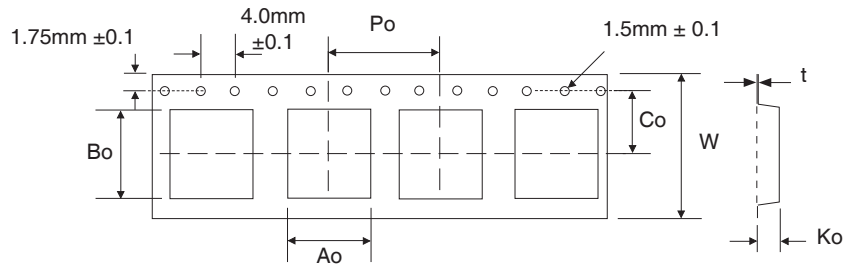

Tape Width	REEL DIMENSIONS (mm)			
	A(mm)	B(mm)	C(mm)	D(mm)
NPI31LS	9.0 ± 1.5	58 ± 2.0	13.5 ± 0.2	178 ± 2.0
NPI32LS				
NPI35LS				
NPI41LS	12.4 +0.2/-0	100 ± 2.0	13.0 +2/-0	330 ± 2.0
NPI42LS				
NPI43LS				
NPI63LS				
NPI64LS				
NPI84LS	16.4 +0.2/-0	100 ± 2.0	13.0 +2/-0	330 ± 2.0

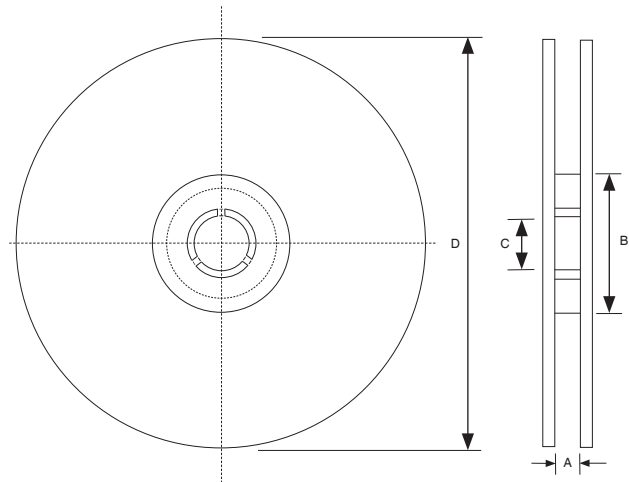

X-ON Electronics

Largest Supplier of Electrical and Electronic Components

Click to view similar products for [Multilayer Ceramic Capacitors MLCC - SMD/SMT](#) category:

Click to view products by [NIC](#) manufacturer:

Other Similar products are found below :

[M39014/01-1467](#) [M39014/02-1218V](#) [M39014/02-1225V](#) [M39014/02-1262V](#) [M39014/02-1301](#) [M39014/22-0631](#) [1210J5000102JCT](#)
[1210J2K00102KXT](#) [1210J5000103KXT](#) [1210J5000223KXT](#) [D55342E07B379BR-TR](#) [D55342E07B523DR-T/R](#) [1812J1K00103KXT](#)
[1812J1K00473KXT](#) [1812J2K00680JCT](#) [1812J4K00102MXT](#) [1812J5000102JCT](#) [1812J5000103JCT](#) [1812J5000682JCT](#) [NIN-FB391JTRF](#)
[NIN-FC2R7JTRF](#) [NPIS27H102MTRF](#) [C1206C101J1GAC](#) [C1608C0G1E472JT000N](#) [C2012C0G2A472J](#) [2220J2K00101JCT](#)
[KHC201E225M76N0T00](#) [LRC-LRF1206LF-01R025FTR1K](#) [1812J1K00222JCT](#) [1812J2K00102KXT](#) [1812J2K00222KXT](#)
[1812J2K00472KXT](#) [2-1622820-7-CUT-TAPE](#) [2220J3K00102KXT](#) [2225J2500824KXT](#) [CCR07CG103KM](#) [CGA2B2C0G1H010C](#)
[CGA2B2C0G1H040C](#) [CGA2B2C0G1H050C](#) [CGA2B2C0G1H060D](#) [CGA2B2C0G1H070D](#) [CGA2B2C0G1H151J](#) [CGA2B2C0G1H1R5C](#)
[CGA2B2C0G1H2R2C](#) [CGA2B2C0G1H3R3C](#) [CGA2B2C0G1H680J](#) [CGA2B2C0G1H6R8D](#) [CGA2B2X8R1H221K](#) [CGA2B2X8R1H472K](#)
[CGA3E1X7R1C474K](#)