

# Hybrid Aluminum Electrolytic Capacitors

NSPE-H Series

- CYLINDRICAL V-CHIP CONSTRUCTION FOR SURFACE MOUNTING
- EXTENDED LOAD LIFE AT HIGH TEMPERATURE (2000 ~ 10,000 HOURS @ +105°C)
- HIGH VOLTAGE RATINGS (16 ~ 125VDC)
- LOW ESR AND HIGH RIPPLE CURRENT RATINGS
- 6.3x4.8mm ~ 10x12.8mm CASE SIZES
- REFLOW SOLDERING RATED UP TO +260°C
- MEETS THE REQUIREMENTS OF AEC-Q200\*

Available with Wide  
Anti-Vibration, Terminations

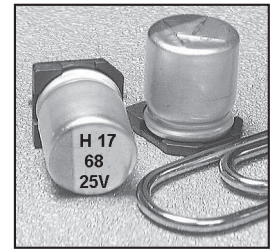

\*Contact NIC for supporting test data

## CHARACTERISTICS

Rated Voltage Range	16 ~ 125Vdc		
Rated Capacitance Range	2.7 ~ 560 $\mu$ F		
Operating Temp. Range	-55 ~ +105°C		
Capacitance Tolerance	$\pm$ 20% (M)		
Max. Leakage Current After 2 Minutes @ 20°C	16 ~ 63Vdc	Less than 0.01CV or 3 $\mu$ A whichever is greater	
	80 ~ 125Vdc	Less than 0.05CV or 100 $\mu$ A whichever is greater	
Working and Surge Voltage Ratings	W.V. (Vdc)	16    25    35    40    50    63    80    100    125	
	S.V. (Vdc)	20    32    44    50    63    79    100    125    157	
Tan $\delta$ @ 120Hz/20°C		0.16	
Impedance Ratio	Z -55°C/Z +20°C	1 ~ 2.5	
	Z +105°C/Z +20°C	0.6 ~ 1.0	
Load Life Test @ 105°C and Rated Voltage	W.V. (Vdc)	16    25    35    40    50    63    80    100    125	
	Case Dia.	6.3x4.8mm	-    2000 hrs.    -    -    -    -    -    -
		$\phi$ 6.3mm	3000 hrs.    5000 hrs.    -    -    -
		$\phi$ 8 & 10mm	7000 hrs.    10000 hrs.    -    -    -
	Capacitance Change	Within $\pm$ 30% of initial measured value	
	Tan $\delta$ and ESR	Less than 200% of specified max. value	
Leakage Current	Less than specified max. value		

## STANDARD PRODUCTS AND CASE SIZES D $\phi$ x L (mm)

PART NUMBER	Cap. ( $\mu$ F)	Working Voltage	Case Size (D X L) mm	Max. Tan $\delta$ 120Hz/20°C	Max. ESR (m $\Omega$ ) AT 100KHz/20°C	Max. Ripple Current (mA rms) AT 100KHz/105°C	Load Life Hours (+105°C)
NSPE-H820M16V6.3X6.3NBF	82	16	6.3X6.3	0.16	55	1330	3000
NSPE-H121M16V6.3X8NBF	120		6.3X8	0.16	40	1500	3000
NSPE-H271M16V8X10.8NBF	270		8X10.8	0.16	26	2000	7000
NSPE-H471M16V10X10.8NBF	470		10X10.8	0.16	21	2600	7000
NSPE-H561M16V10X12.8NBF	560		10X12.8	0.16	15	3000	7000
NSPE-H270M25V6.3X4.8LBF	27	25	6.3X4.8	0.16	95	800	2000
NSPE-H470M25V6.3X6.3NBF	47		6.3X6.3	0.16	60	1270	5000
NSPE-H680M25V6.3X8NBF	68		6.3X8	0.16	45	1400	5000
NSPE-H151M25V8X10.8NBF	150		8X10.8	0.16	27	1900	10000
NSPE-H271M25V10X10.8NBF	270		10X10.8	0.16	22	2530	10000
NSPE-H331M25V10X12.8NBF	330		10X12.8	0.16	16	2900	10000
NSPE-H120M35V6.3X4.8LBF	12	35	6.3X4.8	0.16	150	640	2000
NSPE-H270M35V6.3X6.3NBF	27		6.3X6.3	0.16	100	1080	5000
NSPE-H470M35V6.3X8NBF	47		6.3X8	0.16	60	1300	5000
NSPE-H101M35V8X10.8NBF	100		8X10.8	0.16	30	1800	10000
NSPE-H151M35V10X10.8NBF	150		10X10.8	0.16	23	2470	10000
NSPE-H221M35V10X12.8NBF	220		10X12.8	0.16	17	2830	10000
NSPE-H180M40V6.3X6.3NBF	18	40	6.3X6.3	0.16	110	1030	5000
NSPE-H270M40V6.3X8NBF	27		6.3X8	0.16	70	1250	5000
NSPE-H560M40V8X10.8NBF	56		8X10.8	0.16	32	1750	10000
NSPE-H101M40V10X10.8NBF	100		10X10.8	0.16	24	2400	10000
NSPE-H121M40V10X12.8NBF	120		10X12.8	0.16	18	2750	10000
NSPE-H5R6M50V6.3X6.3NBF	5.6	50	6.3X6.3	0.16	120	980	5000
NSPE-H100M50V6.3X6.3NBF	10		6.3X6.3	0.16	120	980	5000

For Automotive Applications See Part Numbering System



## STANDARD PRODUCTS AND CASE SIZES D $\phi$ x L (mm)

PART NUMBER	Cap. ( $\mu$ F)	Working Voltage	Case Size (D X L) mm	Max. Tan $\delta$ 120Hz/20°C	Max. ESR (m $\Omega$ ) AT 100KHz/20°C	Max. Ripple Current (mA rms) AT 100KHz/105°C	Load Life Hours (+105°C)
NSPE-H100M50V6.3X8NBF	10	50	6.3X8	0.16	80	1200	5000
NSPE-H150M50V6.3X8NBF	15		6.3X8	0.16	80	1200	5000
NSPE-H330M50V8X10.8NBF	33		8X10.8	0.16	35	1670	10000
NSPE-H560M50V10X10.8NBF	56		10X10.8	0.16	25	2320	10000
NSPE-H820M50V10X12.8NBF	82		10X12.8	0.16	19	2650	10000
NSPE-H2R7M63V6.3X6.3NBF	2.7	63	6.3X6.3	0.16	150	960	5000
NSPE-H3R9M63V6.3X8NBF	3.9		6.3X8	0.16	100	1060	5000
NSPE-H6R8M63V6.3X6.3NBF	6.8		6.3X6.3	0.16	150	960	5000
NSPE-H100M63V6.3X8NBF	10		6.3X8	0.16	100	1060	5000
NSPE-H220M63V8X10.8NBF	22		8X10.8	0.16	40	1560	10000
NSPE-H330M63V8X10.8NBF	33		8X10.8	0.16	40	1560	10000
NSPE-H330M63V10X10.8NBF	33		10X10.8	0.16	30	2100	10000
NSPE-H470M63V10X10.8NBF	47		10X10.8	0.16	30	2100	10000
NSPE-H560M63V10X12.8NBF	56		10X12.8	0.16	22	2400	10000
NSPE-H120M80V10X10.8LBF	12		80	10X10.8	0.16	70	1600
NSPE-H150M80V10X10.8LBF	15	10X10.8		0.16	70	1600	10000
NSPE-H180M80V10X12.8LBF	18	10X12.8		0.16	50	1830	10000
NSPE-H100M100V10X10.8LBF	10	100	10X10.8	0.16	80	1450	10000
NSPE-H120M100V10X10.8LBF	12		10X10.8	0.16	80	1450	10000
NSPE-H150M100V10X12.8LBF	15		10X12.8	0.16	60	1660	10000
NSPE-H100M125V10X10.8LBF	10	125	10X10.8	0.16	90	1250	10000

## RIPPLE CURRENT FREQUENCY CORRECTION FACTORS

Cap. $\mu$ F	100Hz	1KHz	10KHz	100KHz
C $\leq$ 4.7	0.03	0.30	0.65	1.00
5.6 ~ 33	0.05	0.32	0.67	1.00
> 33	0.10	0.35	0.70	1.00

### PRECAUTIONS

Please review the notes on correct use, safety and precautions found at <https://www.niccomp.com/resource/files/aluminum/AlumApplInfoCautions.pdf>  
 If in doubt or uncertainty, please review your specific application - process details with  
 NIC's technical support personnel: [tpmg@niccomp.com](mailto:tpmg@niccomp.com)



### PART NUMBER SYSTEM

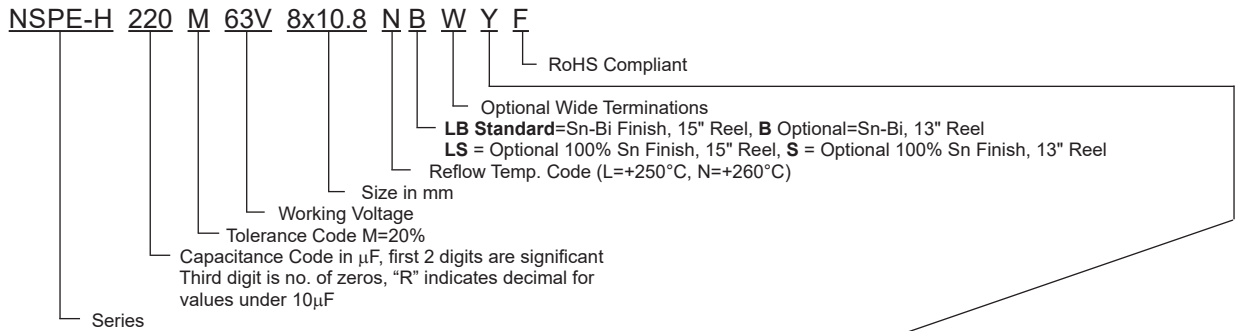

Optional: Suitable for automotive equipment, sourced to special production and inspection at IATF-16949 certified production site

Code	Plating	Termination Type	Automotive	Reel Size
LB	Sn-Bi	Standard	No	Standard 15" Reel
LBW	Sn-Bi	Wide Terminations	No	Standard 15" Reel
LBY	Sn-Bi	Standard	Yes	Standard 15" Reel
LBWY	Sn-Bi	Wide Terminations	Yes	Standard 15" Reel
B	Sn-Bi	Standard	No	Optional 13" Reel
BW	Sn-Bi	Wide Terminations	No	Optional 13" Reel
BY	Sn-Bi	Standard	Yes	Optional 13" Reel
BWY	Sn-Bi	Wide Terminations	Yes	Optional 13" Reel
LS	100% Sn	Standard	No	Standard 15" Reel
LSW	100% Sn	Wide Terminations	No	Standard 15" Reel
LSY	100% Sn	Standard	Yes	Standard 15" Reel
LSWY	100% Sn	Wide Terminations	Yes	Standard 15" Reel
S	100% Sn	Standard	No	Optional 13" Reel
SW	100% Sn	Wide Terminations	No	Optional 13" Reel
SY	100% Sn	Standard	Yes	Optional 13" Reel
SWY	100% Sn	Wide Terminations	Yes	Optional 13" Reel

### COMPONENT DIMENSIONS (mm)

Case Size	$D\phi \pm 0.5$	L max.	A, B $\pm 0.2$	W	$l \pm 0.2$	$P \pm 0.2$
6.3X4.8	6.3	4.8	6.6	0.5 ~ 0.8	2.5	2.2
6.3X6.3	6.3	6.3	6.6	0.5 ~ 0.8	2.5	2.2
6.3X8	6.3	8.0	6.6	0.5 ~ 0.8	2.5	2.2
8X10.8	8.0	10.8	8.3	0.7 ~ 1.0	2.9	3.2
10X10.8	10	10.8	10.3	1.0 ~ 1.4	3.2	4.6
10X12.8	10	12.8	10.3	1.0 ~ 1.4	3.2	4.6

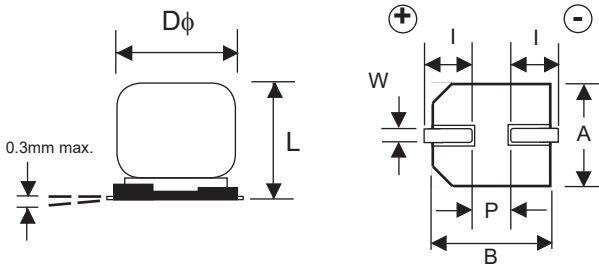

### STANDARD TERMINATION LAND PATTERN DIM. (mm)

Case Dia.	A	B	P
6.3	3.6	1.8	1.8
8	4.1	2.1	2.8
10	4.4	2.5	4.3

### Part Marking

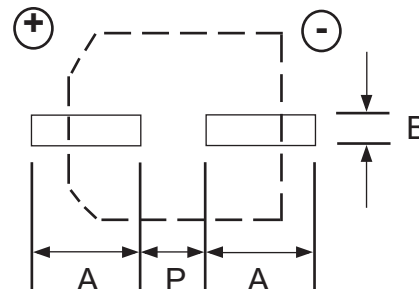
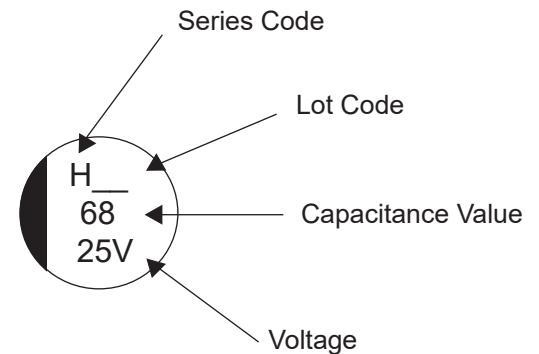

W (Wide Terminations) Anti-Vibration Test	
Test Method	Direction: X, Y, Z axis Frequency & Duration: 5 to 2000Hz reciprocation for 20 minutes, 2 hours each direction Peak to Peak Amplitude: 5mm Peak Acceleration: 30G Sweep Type: Log
Δ Capacitance	Within ± 10% of initial value
Tangent of Loss	≤ Specified value
Leakage Current	≤ Specified value

### WIDE TERMINATION DIM. (mm)

Case Size	Dφ ±0.5	L max.	A, B	C ±0.2	P ±0.2	W	R	T
6.3x6.3WT	6.3	6.5	6.6 ± 0.2	7.3	(2.2)	0.5 ~ 0.8	(1.7)	(0.7)
6.3x8WT	6.3	8.2	6.6 ± 0.2	7.8	(2.2)	0.5 ~ 0.8	(1.7)	(0.7)
8 x 10.8WT	8.0	11.0	8.3 ± 0.2	9.0	3.2	0.7 ~ 1.0	(0.7)	(1.3)
10 x 10.8WT	10.0	11.0	10.3 ± 0.2	11.0	4.6	1.0 ~ 1.4	(0.7)	(1.3)
10 x 12.8WT	10.0	13.5	10.3 ± 0.2	11.0	4.6	1.0 ~ 1.4	(0.7)	(1.3)

### WIDE TERMINATION LAND PATTERN DIM. (mm)

Case Size	a	b	c
6.3x6.3	1.6	4.0	3.0
6.3x8	1.6	4.0	3.0
8x10.8	2.5	4.5	4.7
10x10.8	3.8	4.8	4.7
10x12.8	3.8	4.8	4.7

#### WT STYLE TERMINATION

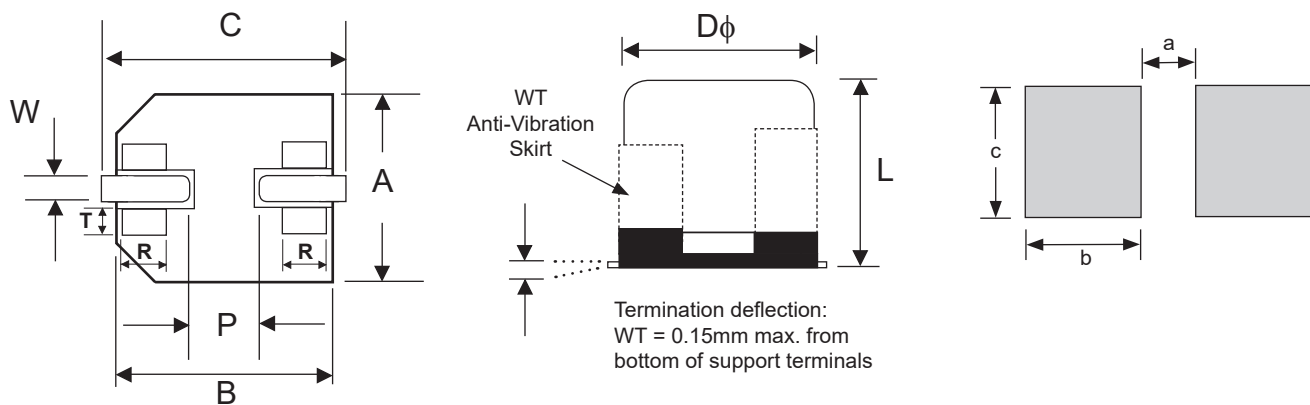

Review & Compare Reflow Soldering Heat Limits  
V-chip SMT Aluminum Electrolytic Capacitors  
[www.niccomp.com/RSL](http://www.niccomp.com/RSL)



## RECOMMENDED REFLOW SOLDERING PROFILE\*

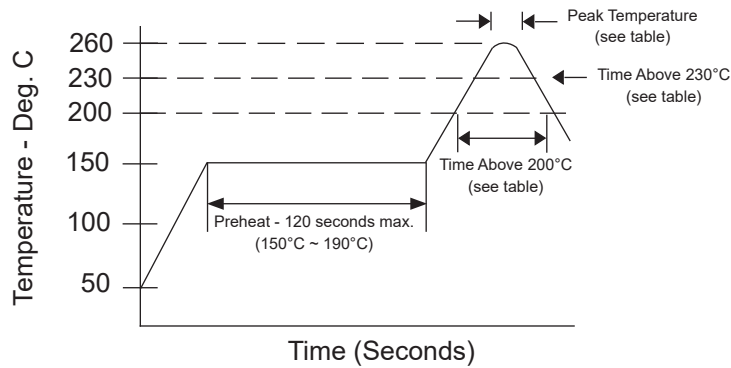

### PEAK TEMPERATURE AND DURATION (16V ~ 63V)

Diameter	Time above 200°C	Time above 217°C	Time above 230°C	Peak Temperature
6.3X4.8mm	60 sec. max.	50 sec. max.	30 sec. max.	250°C/5 sec.
6.3 ~ 10mm	100 sec. max.	80 sec. max.	40 sec. max.	260°C/5 sec.

### PEAK TEMPERATURE AND DURATION (80V ~ 125V)

Diameter	Time above 200°C	Time above 217°C	Time above 230°C	Peak Temperature
10mm	100 sec. max.	80 sec. max.	40 sec. max.	250°C/5 sec.

\*Two reflow passes are permissible with a cool down to room temperature required between the first and second pass.

### TAPING SPECIFICATIONS (mm)

- Both Leader and Trailer tape: Minimum 40mm (1.57") empty carrier tape pockets.
- Leader tape: Approximately 20cm of cover tape at leader.
- Connection: Maximum 3 connections (slices) per reel.

Case Size	A ±0.5	B ±0.5	C ±0.3	D ±0.1	P ±0.1	T ±0.2	t max.
6.3X4.8	7.0	7.0	16.0	7.5	12.0	5.1	0.6
6.3X6.3	7.0	7.0	16.0	7.5	12.0	6.5	0.6
6.3X8	7.0	7.0	16.0	7.5	12.0	8.2	0.6
8X10.8	8.7	8.7	24.0	11.5	16.0	11.0	0.6
10X10.8	10.7	10.7	24.0	11.5	16.0	11.0	0.6
10X12.8	10.7	10.7	24.0	11.5	16.0	13.3	0.6

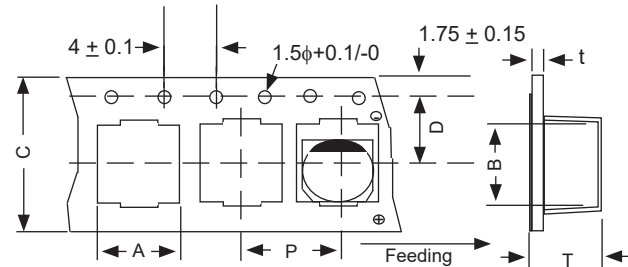

### Standard V-Chip 15" (380mm) Reels (LB suffix)

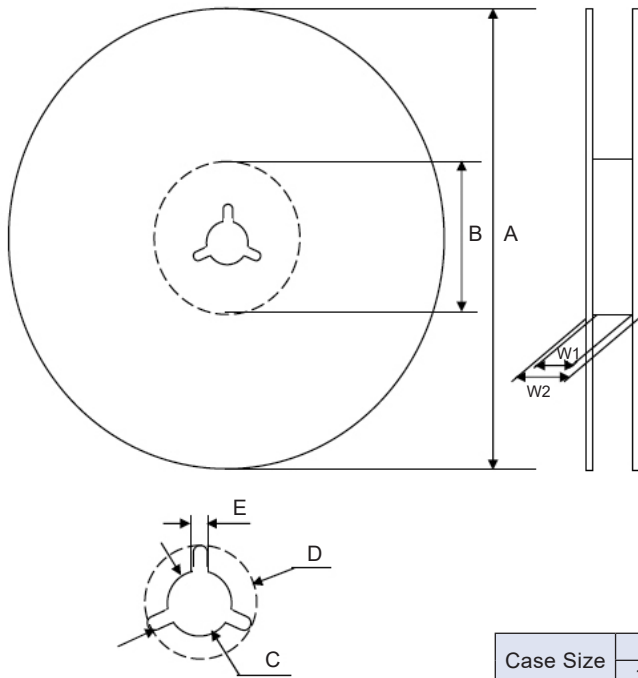

#### Dimensions (mm)

Case Size	Tape Width	W1	W2
6.3x6.3, 6.3x8	16.0	16.5 ~ 18.5	19.5 ~ 24.0
8x10.8, 10x10.8, 10x12.8	24.0	24.5 ~ 26.5	27.5 ~ 32.0

Case Size	Tape Width	A	B	C	D	E
6.3x6.3, 6.3x8	16.0	$\phi 380$ $\pm 2$	$\phi 80 \sim 105$	$\phi 13$ $\pm 0.5$	$\phi 21$ $\pm 1.0$	2.0 $\pm 0.5$
8x10.8, 10x10.8, 10x12.8	24.0					

Color
Black

Case Size	Qty per Reel	
	13" (330mm)	15" (380mm)
6.3X4.8	1000	-
6.3X6.3	800	1000
6.3X8	500	900
8X10.8	300	500
10X10.8	300	500
10X12.8	300	400

### Optional V-Chip 13" (330mm) Reels (B suffix)

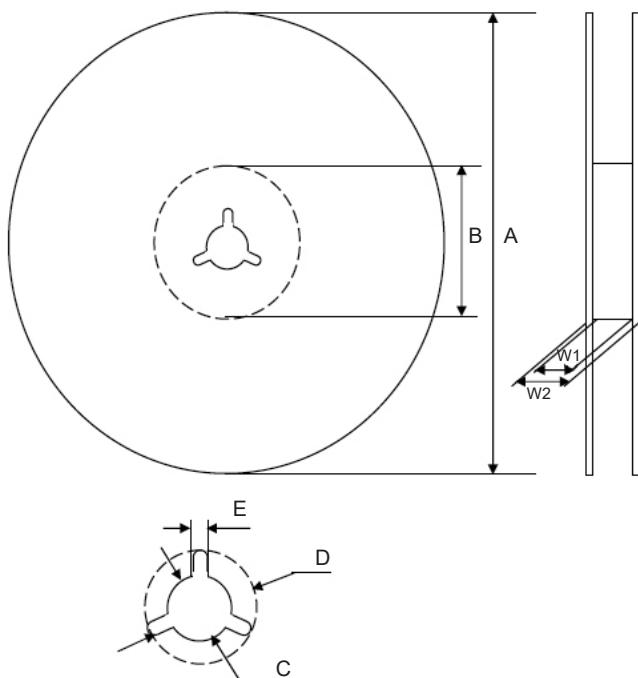

#### Dimensions (mm)

Case Size	Tape Width	W1	W2
6.3x4.8, 6.3x6.3, 6.3x8	16.0	16.4 ~ 18.5	19.5 ~ 24.0
8x10.8, 10x10.8, 10x12.8	24.0	24.4 ~ 26.5	27.5 ~ 32.0

Case Size	Tape Width	A	B	C	D	E
6.3x4.8, 6.3x6.3, 6.3x8	16.0	$\phi 330$ $\pm 2.0$	$\phi 50 \sim 105$	$\phi 13$ $\pm 0.5$	$\phi 21$ $\pm 1.0$	2.0 $\pm 0.5$
8x10.8, 10x10.8, 10x12.8	24.0					

Color
Black

## X-ON Electronics

Largest Supplier of Electrical and Electronic Components

*Click to view similar products for [nic manufacturer](#):*

Other Similar products are found below :

[NMC0603NPO0R6B50TRPF](#) [NMC0603NPO270J100TRPF](#) [NMC1206X5R226K6.3TRPLP2KF](#) [NRE-S100M25V4X7F](#) [NRE-  
HS102M25V12.5X16F](#) [NRCA12F1001TRQYF](#) [NRC-S06F2212TRF](#) [NCD180J1KVNPOJTRF](#) [NRC-S06F1692TRF](#)  
[NCD102M1KVZ5U.250STRF](#) [NTC-T105K20TRAF](#) [NMC-P1206X7R104K100TRPF](#) [NMC-H1206NPO471K1KVTRPLPF](#) [NML04J9N1TRF](#)  
[NRSNA4I4J150TR40KF](#) [NCC0805F261HTRF](#) [NRWA470M35V6.3X11TBF](#) [NACE221M16V6.3X8TR13F](#) [NRSS332M50V18X35.5F](#)  
[NDTM106K25F1TRF](#) [NACZ221M50V10X10.5TR13F](#) [NCM15X7R103K50F](#) [NCD103M1KVZ5UF](#) [NRSS682M25V18X35.5F](#)  
[NEXC224Z5.5V10.5X8.5TRF](#) [NRLRW221M450V30X35SF](#) [NDTM225K50F2TRF](#) [NEXT105Z5.5V21.5X13F](#) [NRSZ471M50V12.5X20F](#)  
[NTCL106K35TRDF](#) [NRWA331M25V10X12.5F](#) [NRSY472M25V16X31.5F](#) [NEXS105Z5.5V28.5X14F](#) [NRLR181M400V25X30SF](#)  
[NRSZ102M25V12.5X20F](#) [NUVA33T385TRF](#) [NUVA33V405TRF](#) [NRLMW331M250V30X25F](#) [NRLF103M25V35X20F](#) [NDTM106K35F](#)  
[NRLMW102M200V35X35F](#) [NPIS43LS220MTRF](#) [NDTM476K35F2F](#) [NTC-T475K50TRDF](#) [NCD222M1KVZ5UKF](#)  
[NRLR472M63V25X40SF](#) [NTP157M10TRD\(40\)F](#) [NPIM74C3R3MTRF](#) [NPI104C100MTRF](#) [NRLM102M100V25X25F](#)