

FEATURES

- PRECISE TOLERANCE AND TEMPERATURE COEFFICIENT
- EIA STANDARD CASE SIZES (0201 ~ 2512)
- LOW NOISE, THIN FILM (NiCr) CONSTRUCTION
- REFLOW SOLDERABLE (Pb FREE TERMINATION FINISH)

RoHS
Compliant
includes all homogeneous materials

*See Part Number System for Details



| Type | EIA Size | Power Rating at 70°C | Max.*1 Working Voltage | Max.*2 Overload Voltage | Resistance Tolerance (Code) | Temperature Coefficient (ppm/°C) | Resistance Range (Ω) | Resistance Values |
|------------|----------|----------------------|------------------------|-------------------------|---|----------------------------------|----------------------|--------------------|
| NTR02 | 0201 | 1/32 (0.032)W | 15V | 30V | ±0.5% (D), ±1.0% (F) | ±25 (C) | 49.9 ~ 4.99KΩ | E-24, E-96 & E-192 |
| | | | | | ±0.5% (D), ±1.0% (F) | ±50 (D) | 49.9 ~ 33KΩ | |
| NTR04 | 0402 | 1/16 (0.063)W | 25V | 50V | ±0.01% (T), ±0.05% (A), ±0.1% (B), ±0.01% (T), ±0.05% (A), ±0.1% (B), ±0.25 (C), ±0.5% (D), ±1% (F) | ±2 (X), ±3 (O) | 49.9 ~ 4.99KΩ | |
| | | | | | ±0.01% (T), ±0.05% (A) | ±5 (S) | 49.9 ~ 4.99KΩ | |
| | | | | | ±0.01% (T), ±0.05% (A) | ±10 (B) | 49.9 ~ 12KΩ | |
| | | | | | ±0.1% (B), ±0.25 (C), ±0.5% (D), ±1% (F) | ±10 (B) | 49.9 ~ 60.4KΩ | |
| | | | | | ±0.01% (T), ±0.05% (A) | ±15 (N) | 49.9 ~ 12KΩ | |
| | | | | | ±0.1% (B), 0.25 (C), ±0.5% (D), ±1% (F) | ±15 (N) | 49.9 ~ 69.8KΩ | |
| | | | | | ±0.05% (A) | ±25(C), ±50(D) | 49.9 ~ 12KΩ | |
| | | | | | ±0.1% (B) | ±25 (C) | 10 ~ 511KΩ | |
| | | | | | ±0.25% (C), ±0.5% (D), ±1% (F) | ±25 (C) | 4.7 ~ 511KΩ | |
| | | | | | ±0.1% (B) | ±50 (D) | 10 ~ 511KΩ | |
| ±0.25% (C) | ±50 (D) | 4.7 ~ 511KΩ | | | | | | |
| NTR06 | 0603 | 1/16 (0.063)W | 50V | 100V | ±0.01% (T), ±0.05% (A), ±0.1% (B), ±0.01% (T), ±0.05% (A), ±0.1% (B), ±0.25 (C), ±0.5% (D), ±1% (F) | ±2 (X), ±3 (O) | 24.9 ~ 15KΩ | |
| | | | | | ±0.01% (T), ±0.05% (A), ±0.1% (B), ±0.25 (C), ±0.5% (D), ±1% (F) | ±5 (S) | 24.9 ~ 15KΩ | |
| | | | | | ±0.01% (T) | ±10(B), ±15(N) | 24.9 ~ 100KΩ | |
| | | | | | ±0.05% (A) | ±10(B), ±15(N) | 4.7 ~ 332KΩ | |
| | | | | | ±0.1% (B), ±0.25 (C), ±0.5% (D), ±1% (F) | ±10(B), ±15(N) | 4.7 ~ 511KΩ | |
| | | | | | ±0.05% (A) | ±25(C), ±50(D) | 4.7 ~ 332KΩ | |
| NTR10 | 0805 | 1/10 (0.10) W | 100V | 200V | ±0.01% (T), ±0.05% (A), ±0.1% (B), ±0.01% (T), ±0.05% (A), ±0.1% (B), ±0.25 (C), ±0.5% (D), ±1% (F) | ±2 (X), ±3 (O) | 24.9 ~ 30KΩ | |
| | | | | | ±0.01% (T) | ±10(B), ±15(N) | 24.9 ~ 200KΩ | |
| | | | | | ±0.05% (A), ±0.1% (B), ±0.25 (C), ±0.5% (D), ±1% (F) | ±10(B), ±15(N) | 4.7 ~ 1MΩ | |
| | | | | | ±0.05 (A) | ±25(C), ±50(D) | 4.7 ~ 1MΩ | |
| | | | | | ±0.1% (B) | ±25(C), ±50(D) | 4.7 ~ 2MΩ | |
| | | | | | ±0.25 (C), ±0.5 (D), ±1% (F) | ±25(C), ±50(D) | 1.0 ~ 2MΩ | |
| NTR12 | 1206 | 1/8 (0.125) W | 150V | 300V | ±0.01% (T), ±0.05% (A), ±0.1% (B), ±0.01% (T), ±0.05% (A), ±0.1% (B), ±0.25 (C), ±0.5% (D), ±1% (F) | ±2 (X), ±3 (O) | 24.9 ~ 49.9KΩ | |
| | | | | | ±0.01% (T), ±0.05% (A), ±0.1% (B), ±0.25 (C), ±0.5% (D), ±1% (F) | ±5 (S) | 24.9 ~ 49.9KΩ | |
| | | | | | ±0.01% (T) | ±10(B), ±15(N) | 24.9 ~ 499KΩ | |
| | | | | | ±0.05% (A), ±0.1% (B), ±0.25 (C), ±0.5% (D), ±1% (F) | ±10(B), ±15(N) | 4.7 ~ 1MΩ | |
| | | | | | ±0.05% (A) | ±25(C), ±50(D) | 4.7 ~ 1MΩ | |
| | | | | | ±0.1% (B) | ±25(C), ±50(D) | 4.7 ~ 2.49MΩ | |
| | | | | | ±0.25% (C), ±0.5% (D), ±1% (F) | ±25(C), ±50(D) | 1.0 ~ 2.49MΩ | |

For 2010 and 2512 case sizes see page 2



| Type | EIA Size | Power Rating at 70°C | Max.*1 Working Voltage | Max.*2 Overload Voltage | Resistance Tolerance (Code) | Temperature Coefficient (ppm/°C) | Resistance Range (Ω) | Resistance Values |
|-------|----------|----------------------|------------------------|-------------------------|---|----------------------------------|----------------------|--------------------|
| NTR20 | 1210 | 1/4 (0.25) W | 150V | 300V | ±0.01% (T), ±0.05% (A), ±0.1% (B), ±0.25% (C), ±0.5% (D), ±1% (F) | ±2 (X), ±3 (O) | 24.9 ~ 49.9KΩ | E-24, E-96 & E-192 |
| | | | | | ±0.01% (T) | ±5 (S) | 24.9 ~ 49.9KΩ | |
| | | | | | ±0.01% (T) | ±10(B), ±15(N) | 24.9 ~ 499KΩ | |
| | | | | | ±0.05% (A), ±0.1% (B), ±0.25% (C), ±0.5% (D), ±1% (F) | ±10(B), ±15(N) | 4.7 ~ 1MΩ | |
| | | | | | ±0.05% (A) | ±25(C), ±50(D) | 4.7 ~ 1MΩ | |
| | | | | | ±0.1% (B) | ±25(C), ±50(D) | 4.7 ~ 2.49MΩ | |
| | | | | | ±0.25% (C), ±0.5% (D), ±1% (F) | ±25(C), ±50(D) | 1.0 ~ 2.49MΩ | |
| NTR25 | 2010 | 1/4 (0.25) W | 150V | 300V | ±0.01% (T), ±0.05% (A), ±0.1% (B), ±0.25% (C), ±0.5% (D), ±1% (F) | ±2 (X), ±3 (O) | 24.9 ~ 100KΩ | |
| | | | | | ±0.01% (T), ±0.05% (A), ±0.1% (B), ±0.25% (C), ±0.5% (D), ±1% (F) | ±5 (S) | 24.9 ~ 100KΩ | |
| | | | | | ±0.01% (T) | ±10(B), ±15(N) | 24.9 ~ 499KΩ | |
| | | | | | ±0.05% (A), ±0.1% (B), ±0.25% (C), ±0.5% (D), ±1% (F) | ±10(B), ±15(N) | 4.7 ~ 1MΩ | |
| | | | | | ±0.05% (A) | ±25(C), ±50(D) | 4.7 ~ 1MΩ | |
| | | | | | ±0.1% (B) | ±25(C), ±50(D) | 4.7 ~ 3MΩ | |
| | | | | | ±0.25% (C), ±0.5% (D), ±1% (F) | ±25(C), ±50(D) | 1.0 ~ 3MΩ | |
| NTR50 | 2512 | 1/2 (0.50) W | 150V | 300V | ±0.01% (T), ±0.05% (A), ±0.1% (B), ±0.25% (C), ±0.5% (D), ±1% (F) | ±2 (X), ±3 (O) | 24.9 ~ 100KΩ | |
| | | | | | ±0.01% (T), ±0.05% (A), ±0.1% (B), ±0.25% (C), ±0.5% (D), ±1% (F) | ±5 (S) | 24.9 ~ 100KΩ | |
| | | | | | ±0.01% (T) | ±10(B), ±15(N) | 24.9 ~ 499KΩ | |
| | | | | | ±0.05% (A), ±0.1% (B), ±0.25% (C), ±0.5% (D), ±1% (F) | ±10(B), ±15(N) | 4.7 ~ 1MΩ | |
| | | | | | ±0.05% (A) | ±25(C), ±50(D) | 4.7 ~ 1MΩ | |
| | | | | | ±0.1% (B) | ±25(C), ±50(D) | 4.7 ~ 3MΩ | |
| | | | | | ±0.25% (C), ±0.5% (D), ±1% (F) | ±25(C), ±50(D) | 1.0 ~ 3MΩ | |

Note *1 - Maximum allowable continuous Working Voltage for all resistors is the lower of the two values:
 "Maximum Working Voltage" as specified above
 or

$$\sqrt{\text{Power rating (Watts)} \times \text{Resistance (Ohms)}}$$

Note *2 - Maximum Overload Voltage for all resistors is the lower of the two values:
 "Maximum Overload Voltage" as specified above
 or

$$2 \times \sqrt{\text{Power rating (Watts)} \times \text{Resistance (Ohms)}}$$

TYPICAL NOISE CHARACTERISTICS

| Resistance Value (Ω) | Case Size | | |
|----------------------|-----------|--------|--------|
| | 0603 | 0805 | 1206 |
| 1 ~ 9 | -95dB | -95dB | -95dB |
| 10 ~ 49 | -85dB | -85dB | -85dB |
| 50 ~ 99 | -85dB | -85dB | -85dB |
| 100 ~ 4.99K | -100dB | -100dB | -105dB |
| 5K ~ 19.9K | -100dB | -100dB | -100dB |
| 20K ~ 1M | -90dB | -100dB | -100dB |

Power Derating Curve: For operation above 70°C, power rating must be derated according to the following chart:



ENVIRONMENTAL CHARACTERISTICS

| Item | Specification | | Typical | | | Test Method* |
|---|-----------------------|----------------------|--------------|---------|---------|---|
| | Tol. ≤ 0.05% | Tol. > 0.05% | Tol. > 0.05% | | | |
| | | | 0402 | 0603 | 0805 | |
| Standard Temperature Range: -55°C ~ +155°C (power derating above +70°C) | | | | | | |
| Temperature Coefficient of Resistance | As specified | As specified | - | - | - | +25/-55/+25/+125/+25 |
| Short Time Overload | ΔR ±0.05% | ΔR ±0.2% | -0.001% | -0.002% | -0.005% | RCWV x 2.5 or Max Overloading Voltage for 5 Seconds |
| Dielectric Withstanding Voltage | As specified | | 265V | 298V | 415V | MIL-STD-202F Method 301 Apply Max. Overload Voltage for 1 minute |
| Insulation Resistance | >1000MΩ | | >10GΩ | | | MIL-STD-202F Method 302 Apply 100Vdc for 1 minute |
| Thermal Shock (N/A 0201 Size) | ΔR ±0.05% | ΔR ±0.25% | 0.001% | -0.02% | 0.002% | MIL-STD-202F Method 107G -55°C ~ +150°C, 100 cycles |
| Load Life | ΔR ±0.05% | ΔR ±0.2% | no change | | | MIL-STD-202F Method 108A RCWV +70°C, 1.5 hours ON, 0.5 hours OFF Total time 1,000 ~ 1,048 hours |
| | >7KΩ ΔR ±0.5% | | 0.02% | 0.03% | 0.06% | |
| Humidity (Steady State) | ΔR ±0.05% | ΔR ±0.3% | 0.003% | 0.005% | 0.007% | MIL-STD-202F Method 103B +40°C, 90% ~ 95% RH, RCWV 1.5 hours ON, 0.5 hours OFF Total time 1,000 ~ 1,048 hours |
| Resistance to Dry Heat (N/A 0201 Size) | ΔR ±0.05% | ΔR ±0.5% | 0.07% | 0.02% | 0.025% | MIL-STD-202 Method 108 +125°C, 1000 hours |
| Low Temperature Operation (N/A 0201 Size) | ΔR ±0.05% | ΔR ±0.2% | 0.006% | 0.008% | 0.001% | JIS-C-502-7.1 1 hour @ -65°C followed by 45 minutes of RCWV |
| Bending Strength | ΔR ±0.05% | ΔR ±0.2% | 0.001% | -0.010% | 0.002% | JIS-C-5202-6.1.4 Bending Amplitude 3mm for 10 seconds |
| Solderability | 95% Minimum Coverage | | >95% | | | MIL-STD-202F Method 208H 245°C ±5°C, 5 ±0.5 seconds |
| Resistance to Soldering Heat | ΔR ±0.05% | ΔR ±0.2% | 0.001% | -0.02% | 0.006% | MIL-STD-202F Method 210E 260°C ±5°C for 10 ±1 seconds |

*0201 testing per IEC 60115 - 1



STANDARD E-24, E-96 AND E-192 VALUES AND 0603 RESISTANCE CODES

| E-24 | | E-96 | | | | | | | | E-192* | | | | | |
|-------|------|-------|------|-------|------|-------|------|-------|------|--------|-------|-------|-------|-------|-------|
| Value | Code | Value | Code | Value | Code | Value | Code | Value | Code | Value | Value | Value | Value | Value | Value |
| 100 | 01 | 100 | 02 | 105 | 03 | 107 | 04 | 100 | 147 | 215 | 316 | 464 | 681 | | |
| 110 | 05 | 113 | 06 | 115 | 07 | 118 | 08 | 101 | 149 | 218 | 320 | 470 | 690 | | |
| 120 | 09 | 124 | 10 | 127 | 11 | 130 | 12 | 102 | 150 | 221 | 324 | 475 | 698 | | |
| 130 | 13 | 137 | 14 | 140 | 15 | 143 | 16 | 104 | 152 | 223 | 328 | 481 | 706 | | |
| 150 | 17 | 150 | 18 | 154 | 19 | 158 | 20 | 105 | 154 | 226 | 332 | 487 | 715 | | |
| 160 | 21 | 165 | 22 | 169 | 23 | 174 | 24 | 106 | 156 | 229 | 336 | 493 | 723 | | |
| 180 | 25 | 182 | 26 | 187 | 27 | 191 | 28 | 107 | 158 | 232 | 340 | 499 | 732 | | |
| 200 | 29 | 200 | 30 | 205 | 31 | 210 | 32 | 109 | 160 | 234 | 344 | 505 | 741 | | |
| 220 | 33 | 221 | 34 | 226 | 35 | 232 | 36 | 110 | 162 | 237 | 348 | 511 | 750 | | |
| 240 | 37 | 243 | 38 | 249 | 39 | 255 | 40 | 111 | 164 | 240 | 352 | 517 | 759 | | |
| 270 | 41 | 267 | 42 | 274 | 43 | 280 | 44 | 113 | 165 | 243 | 357 | 523 | 768 | | |
| 300 | 45 | 294 | 46 | 301 | 47 | 309 | 48 | 114 | 167 | 246 | 361 | 530 | 777 | | |
| 330 | 49 | 324 | 50 | 332 | 51 | 340 | 52 | 115 | 169 | 249 | 365 | 536 | 787 | | |
| 360 | 53 | 357 | 54 | 365 | 55 | 374 | 56 | 117 | 172 | 252 | 370 | 542 | 796 | | |
| 390 | 57 | 392 | 58 | 402 | 59 | 412 | 60 | 118 | 174 | 255 | 374 | 549 | 806 | | |
| 430 | 61 | 432 | 62 | 442 | 63 | 453 | 64 | 120 | 176 | 258 | 379 | 556 | 816 | | |
| 470 | 65 | 475 | 66 | 487 | 67 | 499 | 68 | 121 | 178 | 261 | 383 | 562 | 825 | | |
| 510 | 69 | 523 | 70 | 536 | 71 | 549 | 72 | 123 | 180 | 264 | 388 | 569 | 835 | | |
| 560 | 73 | 576 | 74 | 590 | 75 | 604 | 76 | 124 | 182 | 267 | 392 | 576 | 845 | | |
| 620 | 77 | 634 | 78 | 649 | 79 | 665 | 80 | 126 | 184 | 271 | 397 | 583 | 856 | | |
| 680 | 81 | 698 | 82 | 715 | 83 | 732 | 84 | 127 | 187 | 274 | 402 | 590 | 866 | | |
| 750 | 85 | 768 | 86 | 787 | 87 | 806 | 88 | 129 | 189 | 270 | 407 | 597 | 876 | | |
| 820 | 89 | 845 | 90 | 866 | 91 | 887 | 92 | 130 | 191 | 280 | 412 | 604 | 887 | | |
| 910 | 93 | 931 | 94 | 953 | 95 | 976 | 96 | 132 | 193 | 284 | 417 | 612 | 898 | | |
| | | | | | | | | 133 | 196 | 287 | 422 | 619 | 909 | | |
| | | | | | | | | 135 | 198 | 291 | 427 | 626 | 920 | | |
| | | | | | | | | 137 | 200 | 294 | 432 | 634 | 931 | | |
| | | | | | | | | 138 | 203 | 298 | 437 | 642 | 942 | | |
| | | | | | | | | 140 | 205 | 301 | 442 | 649 | 953 | | |
| | | | | | | | | 142 | 208 | 305 | 448 | 657 | 965 | | |
| | | | | | | | | 143 | 210 | 309 | 453 | 665 | 976 | | |
| | | | | | | | | 145 | 213 | 312 | 459 | 673 | 988 | | |

* Special E192 resistance values are supported on all case sizes of NTR series. Please review your E192 value requirements with NIC, as special terms apply, and E192 values are supplied without component resistance value marking.

MULTIPLIER CODE

| Code | A | B, b | C | D, d | E | F | G | H | X | Y | Z |
|------------|-----------------|-----------------|-----------------|-----------------|-----------------|-----------------|-----------------|-----------------|------------------|------------------|------------------|
| Multiplier | 10 ⁰ | 10 ¹ | 10 ² | 10 ³ | 10 ⁴ | 10 ⁵ | 10 ⁶ | 10 ⁷ | 10 ⁻¹ | 10 ⁻² | 10 ⁻³ |



PART MARKING

- No marking on 0402 case size.
- Marking for 0603 case size:
 E-24 values and E-96 values: $\pm 1\%$ (F), $\pm 0.5\%$ (D), $\pm 0.25\%$ (C), $\pm 0.1\%$ (B) tolerances
 E-192 values: $\pm 0.1\%$ (B) tolerance (No Marking)

CODING FORMULA



Example: $10.2k\Omega = \frac{102}{02} \times \frac{10^2}{C} \Omega = 02C$
 $33.2 \Omega = \frac{332}{51} \times \frac{10^{-1}}{X} = 51X$

MARKING EXAMPLES

10 Ω = 01X
 7.5k Ω = 85B
 150k Ω = 18D
 1 Meg Ω = 01E

- Marking for 0805, 1206, 2010 and 2512 case sizes:
 E-24 and E-96 values - $\pm 1\%$ (F), $\pm 0.5\%$ (D), $\pm 0.25\%$ (C), $\pm 0.1\%$ (B) tolerances
 E-192 values: $\pm 0.1\%$ (B) tolerance (No Marking)

4 DIGIT MARKING SYSTEM - First 3 digits are the significant figures, the 4th digit is the multiplier. "R"= decimal point.

Examples: 0R10 = 0.10 ohms, 1R00 = 1.0 ohms, 22R1=22.1 ohms, 3320= 332 ohms, 4751=4.75K ohms, 1132=11.3K ohms, 6493=649K ohms

PART NUMBER SYSTEM



DIMENSIONS (mm)

| Type | Power Rating | EIA Size | L | W | H | T | t |
|-------|--------------|----------|-------------|-------------|-------------|-------------|-------------|
| NTR02 | 1/32W | 0201 | 0.58 ± 0.05 | 0.29 ± 0.05 | 0.23 ± 0.03 | 0.12 ± 0.05 | 0.15 ± 0.05 |
| NTR04 | 1/16W | 0402 | 1.00 ± 0.05 | 0.50 ± 0.05 | 0.30 ± 0.05 | 0.20 ± 0.10 | 0.20 ± 0.10 |
| NTR06 | 1/16W | 0603 | 1.55 ± 0.10 | 0.80 ± 0.10 | 0.45 ± 0.10 | 0.30 ± 0.20 | 0.30 ± 0.20 |
| NTR10 | 1/10W | 0805 | 2.00 ± 0.15 | 1.25 ± 0.15 | 0.55 ± 0.10 | 0.30 ± 0.20 | 0.40 ± 0.25 |
| NTR12 | 1/8W | 1206 | 3.05 ± 0.10 | 1.55 ± 0.10 | 0.55 ± 0.10 | 0.42 ± 0.20 | 0.35 ± 0.25 |
| NTR20 | 1/4W | 1210 | 3.10 ± 0.15 | 2.40 ± 0.15 | 0.55 ± 0.10 | 0.40 ± 0.20 | 0.55 ± 0.25 |
| NTR25 | 1/4W | 2010 | 4.90 ± 0.15 | 2.40 ± 0.15 | 0.55 ± 0.10 | 0.60 ± 0.30 | 0.50 ± 0.25 |
| NTR50 | 1/2W | 2512 | 6.30 ± 0.15 | 3.10 ± 0.15 | 0.55 ± 0.10 | 0.60 ± 0.30 | 0.50 ± 0.25 |

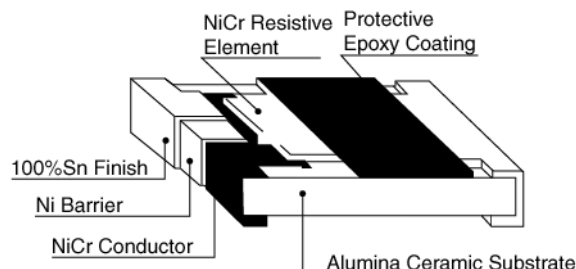
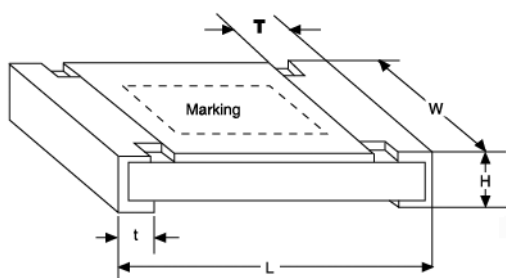

TAPING SPECIFICATIONS

(1) Availability

| Type | Power Rating | EIA Size | Carrier Tape | | | Qty per Reel (pcs) | |
|-------|--------------|----------|--------------|----------|------------|--------------------|----------|
| | | | Fig. | Material | Width (mm) | Standard | Optional |
| NTR02 | 1/32W | 0201 | A | Paper | 8 | 10,000 | 1,000 |
| NTR04 | 1/16W | 0402 | A | | | 10,000 | 1,000 |
| NTR06 | 1/16W | 0603 | A | | | 5,000 | 1,000 |
| NTR10 | 1/10W | 0805 | A | | | | |
| NTR12 | 1/8W | 1206 | A | | | | |
| NTR20 | 1/4W | 1210 | A | | | | |
| NTR25 | 1/4W | 2010 | B | Plastic | 12 | 4,000 | 1,000 |
| NTR50 | 1/2W | 2512 | B | | | | |

(2) PAPER TAPE DIMENSIONS (mm)

FIG. A

| Type | EIA Size | A | B | D | E | F | P ₀ | P ₁ | P ₂ | W | T |
|-------|----------|-------------|-------------|-------------|-------------|-------------|----------------|----------------|----------------|-----------|-------------|
| NTR02 | 0201 | 0.40 ± 0.05 | 0.70 ± 0.05 | 1.55 ± 0.05 | 1.75 ± 0.05 | 3.50 ± 0.05 | 4.0 ± 0.10 | 2.0 ± 0.05 | 2.0 ± 0.05 | 8.0 ± 0.1 | 0.42 ± 0.02 |
| NTR04 | 0402 | 0.70 ± 0.05 | 1.16 ± 0.05 | | | | | 0.40 ± 0.03 | | | |
| NTR06 | 0603 | 1.10 ± 0.05 | 1.90 ± 0.05 | | | | | 0.60 ± 0.03 | | | |
| NTR10 | 0805 | 1.60 ± 0.05 | 2.37 ± 0.05 | | | | | 0.75 ± 0.05 | | | |
| NTR12 | 1206 | 2.00 ± 0.05 | 3.55 ± 0.05 | | | | | | | | |
| NTR20 | 1210 | 2.75 ± 0.05 | 3.40 ± 0.05 | 1.60 ± 0.10 | | | | | | | |

FIG. A

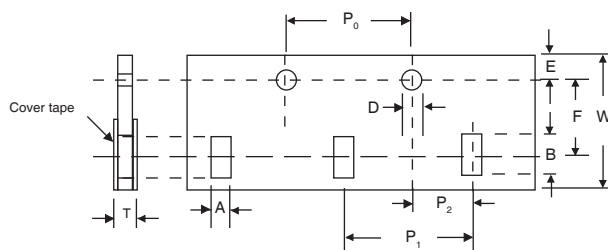

(3) PLASTIC EMBOSSED TAPE DIMENSIONS (mm)

FIG. B

| Type | EIA Size | A | B | D | E | F | P ₀ | P ₁ | P ₂ | W | T |
|-------|----------|-------------|-------------|-------------|-------------|-------------|----------------|----------------|----------------|------------|------------|
| NTR25 | 2010 | 2.85 ± 0.10 | 5.45 ± 0.10 | 1.50 ± 0.10 | 1.75 ± 0.10 | 5.50 ± 0.05 | 4.0 ± 0.10 | 4.0 ± 0.05 | 2.0 ± 0.05 | 12.0 ± 0.1 | 1.0 ± 0.20 |
| NTR50 | 2512 | 3.40 ± 0.10 | 6.65 ± 0.10 | | | | | | | | |

FIG. B

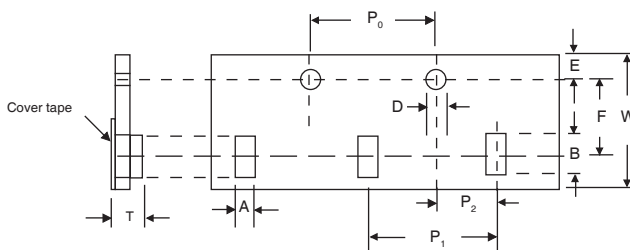

REEL DIMENSIONS (mm)



LAND PATTERN DIMENSIONS (mm)

| Type | EIA Size | A | B | C |
|-------|----------|------|------|------------|
| NTR02 | 0201 | 0.25 | 0.30 | 0.40 ± 0.2 |
| NTR04 | 0402 | 0.50 | 0.50 | 0.60 ± 0.2 |
| NTR06 | 0603 | 0.80 | 1.00 | 0.90 ± 0.2 |
| NTR10 | 0805 | 1.00 | 1.00 | 1.35 ± 0.2 |
| NTR12 | 1206 | 2.00 | 1.15 | 1.70 ± 0.2 |
| NTR20 | 1210 | 2.00 | 1.15 | 2.50 ± 0.2 |
| NTR25 | 2010 | 3.60 | 1.40 | 2.50 ± 0.2 |
| NTR50 | 2512 | 4.90 | 1.60 | 3.10 ± 0.2 |



PEAK REFLOW SOLDERING CONDITIONS

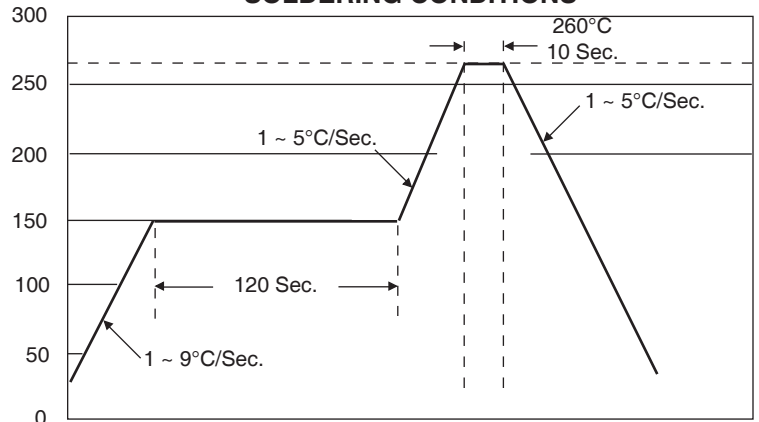

X-ON Electronics

Largest Supplier of Electrical and Electronic Components

Click to view similar products for [Multilayer Ceramic Capacitors MLCC - SMD/SMT category:](#)

Click to view products by [NIC manufacturer:](#)

Other Similar products are found below :

[M39014/01-1467](#) [M39014/02-1218V](#) [M39014/02-1225V](#) [M39014/02-1262V](#) [M39014/02-1301](#) [M39014/22-0631](#) [1210J5000102JCT](#)
[1210J2K00102KXT](#) [1210J5000103KXT](#) [1210J5000223KXT](#) [D55342E07B379BR-TR](#) [D55342E07B523DR-T/R](#) [1812J1K00103KXT](#)
[1812J1K00473KXT](#) [1812J2K00680JCT](#) [1812J4K00102MXT](#) [1812J5000102JCT](#) [1812J5000103JCT](#) [1812J5000682JCT](#) [NIN-FB391JTRF](#)
[NIN-FC2R7JTRF](#) [NPIS27H102MTRF](#) [C1206C101J1GAC](#) [C1608C0G1E472JT000N](#) [C2012C0G2A472J](#) [2220J2K00101JCT](#)
[KHC201E225M76N0T00](#) [1812J1K00222JCT](#) [1812J2K00102KXT](#) [1812J2K00222KXT](#) [1812J2K00472KXT](#) [2-1622820-7-CUT-TAPE](#)
[2220J3K00102KXT](#) [2225J2500824KXT](#) [CCR07CG103KM](#) [CGA2B2C0G1H010C](#) [CGA2B2C0G1H040C](#) [CGA2B2C0G1H050C](#)
[CGA2B2C0G1H060D](#) [CGA2B2C0G1H070D](#) [CGA2B2C0G1H151J](#) [CGA2B2C0G1H1R5C](#) [CGA2B2C0G1H2R2C](#) [CGA2B2C0G1H3R3C](#)
[CGA2B2C0G1H680J](#) [CGA2B2C0G1H6R8D](#) [CGA2B2X8R1H221K](#) [CGA2B2X8R1H472K](#) [CGA3E1X7R1C474K](#)
[CGA3E2C0G1H561JT0Y0N](#)