

Date of application  
Oct. 16. 2009

NICHICON CORPORATION  
NICHICON (OHNO) CORPORATION  
ENGINEERING DIV.

S P E C I F I C A T I O N  
O F  
ALUMINUM ELECTROLYTIC CAPACITORS

UCS2G101MHDAZT

DWG. No.	H091016h4	CHECKED	<i>F. Koba</i>	Oct. 16. 2009	
DESIGNED.	<i>Y. Kobayashi</i>	Oct. 16. 2009	APPROVED	<i>M. Tada</i>	Oct. 16. 2009

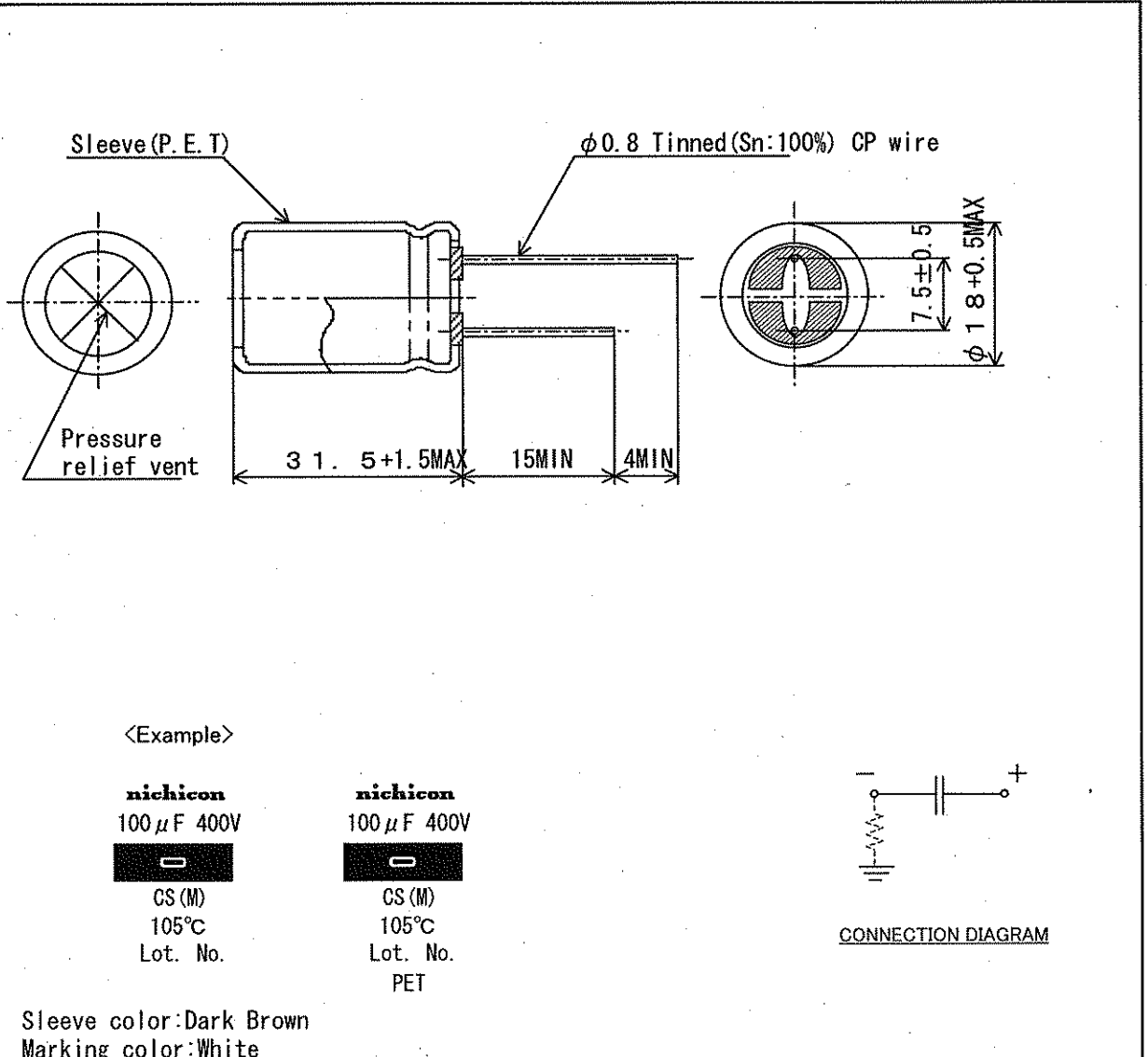

## ELECTRICAL CHARACTERISTICS

WORKING VOLTAGE (V. D. C)	SURGE VOLTAGE (V. D. C)	RATED CAP ( $\mu$ F)	CAP. TOL. (%)	$\tan \delta$ (MAX)	LEAKAGE CURRENT ( $\mu$ A MAX)	RIPPLE CURRENT (mArms MAX)
400	450	100	$\pm 20$	0.24	1700	1720
at 120Hz 20 °C					400 V after 1min	at 100kHz 105°C

TEST STANDARD

JIS C 5101-4

OPERATING TEMP. RANGE

-40 ~ 105°C

				NICHICON TYPE NO.					
				UCS2G101MHDAZT					
				RATE					
				400V		100 $\mu$ F			
				3RD ANGLE PROJEC- TION		SCALE /mm	DATE 2009/10/16	CASE SIZE $\phi 18 \times 31.5$ L	
MARK		DATE		DESCRIPTIONS		APPR.		REVISION	
SPECIFICATION				DWG. No.		H091016h4		sheet	2

## SPECIFICATION ALUMINUM ELECTROLYTIC CAPACITOR

1. SCOPE  
This specification covers polarized aluminum foil drytype electrolytic capacitors.  
( JIS-04 TYPE)
2. APPLICABLE SPECIFICATION  
Japanese Industrial Standard JIS C 5101-4:1998 Characteristics W and  
JIS C-5101-1:1998 except as specified in this specification.
3. PERFORMANCE  
Unless otherwise specified, the standard range of atmospheric conditions  
for making measurements and tests is as follows :  
 Ambient temperature : 5 to 35°C  
 Relative humidity : 45 to 85%  
 Air pressure : 86kPa to 106kPa  
 If there may be any doubt on the results, measurements shall be made within the  
 following limits,  
 Ambient temperature : 20±2°C  
 Relative humidity : 60 to 70%  
 Air pressure : 86kPa to 106kPa

No.	Item	Test method	Performance
3.1	OPERATING TEMPERATURE RANGE		-40 ~ 105 °C
3.2	RATED VOLTAGE		400 V
3.3	CAPACITANCE	at 120Hz±20%	100 μF±20%
3.4	tan δ	at 120Hz±20%	0.24 MAX.
3.5	LEAKAGE CURRENT	To comply with JIS C 5101-1 4.8 After 1 minute's application of rated voltage.(at 20°C)	1700 μA MAX.
3.6	SURGE VOLTAGE	To comply with JIS C 5101-1 4.26 The surge voltage specified in the individual standard shall be applied 1000 times, each for 30±5s, period of 6±0.5min. Electric discharge : Not to carry Out Test temperature : 15~35°C	Capacitance : Not less than 80 % of the value before test. tan δ : Not more than 200 % of the specified value. Leakage current : Initial specified value or less
3.7	IMPEDANCE RATIO AT LOW TEMPERATURE	To comply with JIS C 5101-1 4.10 -25, -40 °C 2h Measurement frequency : 120Hz±20%	Z  <sub>-25°C</sub> / Z  <sub>20°C</sub> ≤ 5  Z  <sub>-40°C</sub> / Z  <sub>20°C</sub> ≤ 6
3.8	TERMINAL STRENGTH	To comply with JIS C 5101-1 4.13 Tensile strength of termination : tensile force holding time tensile force : 10 N Bending strength of termination : Count it as 2 times. Dead weight : 5 N	No abnormality such as cutting off, looseness or the like of termination.
3.9	SOLDERABILITY	To comply with JIS C 5101-1 4.15 Temperature of solder : 235±5°C Dipping time : 2±0.5 s Storage time : after 6 month	At least 3/4 of circumferential surface of the dipped portion of termination shall be covered with new solder.
3.10	RESISTANCE OF SOLDERING	To comply with JIS C 5101-1 4.14 Temp. : 260±5°C Time : 10±1s or Temp. : 350 ±10°C Time : 3 1/2 s	Capacitance change : Within ±10% of initial value tan δ : Initial specified value or less. Leakage current : Initial specified value or less. Appearance : No remarkable abnormality.

No.	Item	Test method	Performance
3.11	RESISTANCE TO DAMP HEAT (STEADY STATE)	To comply with JIS C 5101-1 4.22 Test temperature : $40 \pm 2^{\circ}\text{C}$ Relative humidity : 90~95% Test time : $240 \pm 8\text{h}$	Capacitance change : Within $\pm 15\%$ of initial value $\tan \delta$ : Initial specified value or less. Leakage current : Initial specified value or less. Appearance : No remarkable abnormality.
3.12	LIFE TEST	To comply with JIS C 5101-1 4.23 Test temperature : $105 \pm 2^{\circ}\text{C}$ Test time : $10000 \frac{+72}{-48} \text{h}$  D.C. bias with rated ripple current so that its peak voltage shall not exceed the rated D.C. voltage.	Capacitance change : Within $\pm 20\%$ of initial value $\tan \delta$ : 200 % or less of initial specified value. Leakage current : Initial specified value or less. Appearance : No remarkable abnormality.
3.13	SHELF LIFE TEST	Test temperature : $105 \pm 2^{\circ}\text{C}$ Test time : $1000 \frac{+48}{-36} \text{h}$	Capacitance change : Within $\pm 20\%$ of initial value $\tan \delta$ : 200 % or less of initial specified value. Leakage current : Initial specified value or less. ( Voltage treatment according to JIS C 5101-4 4.1 ) Appearance : No remarkable abnormality.
3.14	RESISTANCE TO VIBRATION	To comply with JIS C 5101-1 4.17 Direction and duration of vibration : 3 orthogonal directions mutually directions mutually each for 2h Total 6 h Frequency : 10 to 55 Hz Reciprocation for 1 min. Total amplitude : 1.5 mm	Capacitance : When the capacitance is measured, there shall be no intermittent contacts, or open or short-circuiting, and no abnormality. Appearance : No remarkable abnormality.
3.15	PRESSURE RELIEF VENT TEST	A.C Application Test The capacitor shall be subjected to an A.C. voltage (50 to 60Hz) with r.m.s value equal to 0.7 times the rated D.C. voltage through a series resistor. The series resistor as follows. $R = 10 \Omega$ D.C Application Test The capacitor shall be subjected to a reverse D.C. voltage equal to the rated D.C. voltage. the current flowing through the capacitor shall be limited to 1A.	There is no fine of the capacitor, when the pressure relief device shall be open, or there is no explosion or fire, etc. of the capacitor when 30 minutes has elapsed from the start of the test.
		NOTE : The test is terminated if the vent device is not when 30 min. has elapsed from the start of the test conducted under the condition.	

#### 4. MARKING

Capacitors shall be legibly marked with following.

- 4-1 Manufacture's Trade mark
- 4-2 Rated voltage
- 4-3 Nominal capacitance
- 4-4 EIA DATE CODE
- 4-5 Negative polarity
- 4-6 Capacitance Tolerance
- 4-7 Maximum operating temperature identification
- 4-8 Series identification
- 4-9 PET sleeve identification

5. OTHERS

• The Relevant Export Regulation Laws:

In case that there is a certain danger of the products conflicting with the use and activity for the developments of weapons of mass destruction, the procedures based upon the relevant export regulation laws are absolutely needed.

• Ozone Depletion Substance

Ozone depletion substances are not used in our production process and at our suppliers.

• Brominated Flame Retardants

The restricted brominated flame retardants are not used.

• Production factory

NICHICON (OHNO) CORPORATION

NICHICON (IWATE) CORPORATION

NICHICON (MALAYSIA) SDN. BHD.

NICHICON ELECTRONICS (WUXI) CO., LTD.

## X-ON Electronics

Largest Supplier of Electrical and Electronic Components

*Click to view similar products for [Aluminium Electrolytic Capacitors - Radial Leaded](#) category:*

*Click to view products by [Nichicon](#) manufacturer:*

Other Similar products are found below :

[LXY50VB4.7M-5X11](#) [RFO-100V471MJ7P#](#) [ECE-A1EGE220](#) [1814181](#) [NCD681K10KVY5PF](#) [NEV1000M25EF-BULK](#) [NEV100M35DC](#)  
[NEV100M63DE](#) [NEV220M25DD-BULK](#) [NEV.33M100AA](#) [NEV4700M50HB](#) [NEV.47M100AA](#) [NEVH1.0M250AB](#) [NEVH3.3M250BB](#)  
[NEVH3.3M450CC](#) [KME50VB100M-8X11.5](#) [SG220M1CSA-0407](#) [ES5107M016AE1DA](#) [ESX472M16B](#) [476CKH100MSA](#) [477RZS050M](#)  
[UVX1V101KPA1FA](#) [UVX1V222MHA1CA](#) [KME25VB100M-6.3X11](#) [VTL100S10](#) [VTL470S10](#) [511D336M250EK5D](#) [052687X](#) [ECE-](#)  
[A1CF471](#) [EKXG451ELL820MM30S](#) [686CKR050M](#) [NRE-S560M16V6.3X7TBSTF](#) [ERZA630VHN182UP54N](#) [UPL1A331MPH](#)  
[NEV1000M6.3DE](#) [NEV100M16CB](#) [NEV100M50DD-BULK](#) [NEV2200M16FF](#) [NEV220M50EE](#) [NEV2.2M50AA](#) [NEV330M63EF](#)  
[NEV4700M35HI](#) [NEV4.7M100BA](#) [NEV47M16BA](#) [NEV47M50CB-BULK](#) [NEVH1.0M350AB](#) [NEVH2.2M160AB](#) [NEVH3.3M350BC](#)  
[TER330M50GM](#) [477KXM035MGBWSA](#)